



Shared components: MASTER dimmer 230V 1000W/VA

01861

Smart systems&products / By-me Plus / Shared components / DIN devices

MASTER dimmer 230V 1000W/VA

Dimmer, 230 V~ 50/60 Hz for: 40-1000 W incandescent lamps, 40-1000 VA ferromagnetic transformers, MASTER function for 01862, protection fuse, MOSFET+TRIAC technology, for DIN (60715 TH35) rail installation, occupies 4 17,5 mm modules



Product Status

2 - Will be discontinued

Minimum order quantity

1 NR

Sheets, Manuals, Documentation

- [FI - Foglio istruzioni ZIS_49400253A0 \(289 kb\)](#)

Drawings



Space view

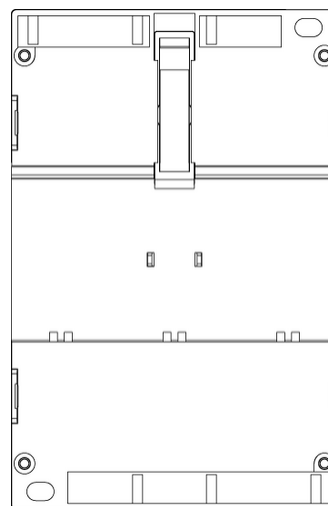
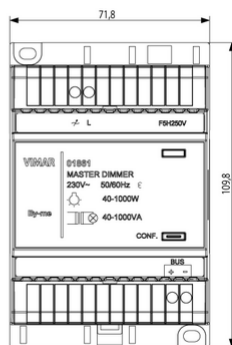

Backside view

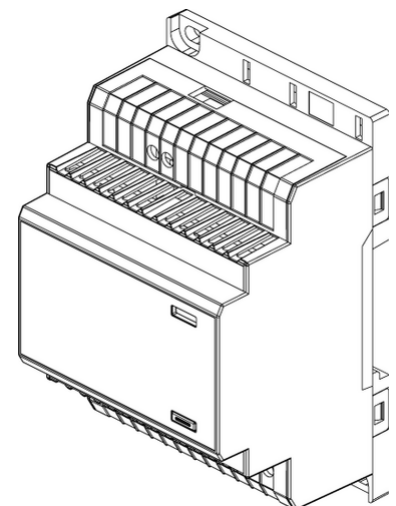

3D View

Certifications

• 00. CE Marking - EU

• 99. WEEE Directive ([download](#))

Technical data

Class group: Installation bus systems

Class: Dimming actuator for bus system

Bus system KNX: No

Bus system KNX-RF (Radio Frequency): No

Bus system radio frequency: No

Bus system LON: No

Bus system Powernet: No

Other bus systems: Other

Radio frequency bidirectional: No

Model: Dimming actuator

Mounting method: Other

Width in number of modular spacings: 4

With bus connection: Yes

Bus module detachable: No

Local operation/hand operation: No

With LED indication: Yes

Number of outputs: 1

Output power: 40 - 1.000 W

Power boost suitable: No

Type of load: Universal

Voltage: 230,00 - 230,01 V

Parallel-service possible: No

Frequency: 50,00 - 60,00 HZ

Degree of protection (IP): IP20

Packaging



8007352387423

Qtà 1 NR

Dim 11.7x10.8x7.1
[cm]

Weight 206.4 [g]

Legal

Vimar reserves the right to change at any time and without notice the characteristics of the products reported. Installation should be carried out by qualified staff in compliance with the current regulations regarding the installation of electrical equipment in the country where the products are installed. For the terms of use of the information on the product info sheet see [Conditions of Use](#).