



Lampholders: Screwtype lamphld-G13 fluor.lamp+start.

02464

Portable installation / Lighting components / Lampholders /
Fluorescent lampholders

Screwtype lamphld-G13 fluor.lamp+start.

2 A 250 V inflexible lampholder, rotor type, with starter holder, brass contacts, for G13 fluorescent tubular lamps, screw fixing and terminals, rated operating temperature 80 °C, white



Product Status

3 - Active

Minimum order quantity

100 NR

Drawings

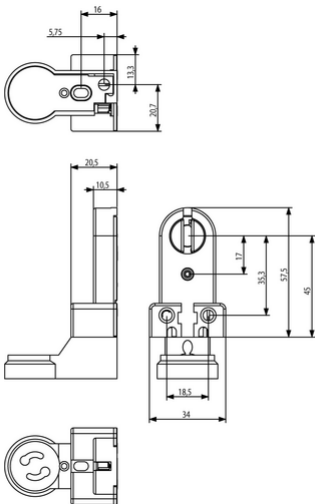

Space view

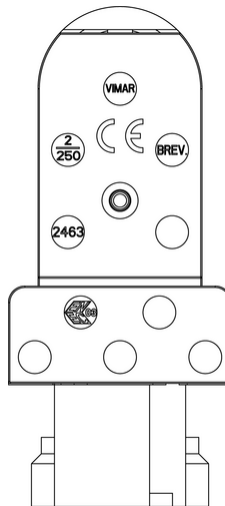

Backside view

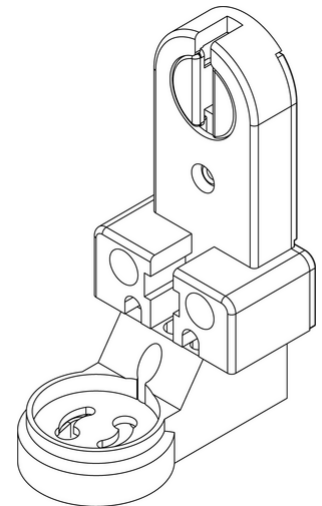

3D View

Certifications

- 00. CE Marking - EU
- 00. CE Marking - EU
- 17. ENEC 03 (IMQ) ([download](#))
- 37. Marking - Morocco
- 96. Electrotechnical expert ([download](#))
- 99. WEEE Directive ([download](#))

Technical data

Class group: Accessories for lighting

Class: Lamp holder

Model: Plug-in lamp holder

Material: Other

Colour: White

Lamp holder: G13

With starter insertion: Yes

Type of fastening: Screw mounting

Nipple thread: 3/8 inch

Packaging



8007352031418

Qtà 1 NR

Dim 3.5x7.6x5 [cm]

Weight 38.4 [g]



8007352349070

Qtà 10 NR

Dim 20x10x3 [cm]

Weight 389 [g]



8007352031425

Qtà 100 NR

Dim 28.4x24.4x16.4 [cm]

Weight 4,094.67 [g]

Legal

Vimar reserves the right to change at any time and without notice the characteristics of the products reported. Installation should be carried out by qualified staff in compliance with the current regulations regarding the installation of electrical equipment in the country where the products are installed. For the terms of use of the information on the product info sheet see [Conditions of Use](#).