



Surface mounting components: By-alarm Plus extension 5 In/Out

03819

Safety / By-alarm Plus / Surface mounting components / Non-modular components

By-alarm Plus extension 5 In/Out

By-alarm Plus 5-terminal In/Out expansion module, configurable for volt-free contacts, roller shutter or vibration detector contacts. If programmed as OC output, max absorption 250 mA. At the +AUX terminals, max 800 mA



Product Status

3 - Active

Minimum order quantity

1 NR

Sheets, Manuals, Documentation

- [Multilanguage instructions sheet \(328 kb\)](#)
- [Feuille d'instructions \(218 kb\)](#)
- [Anwendungshinweise \(218 kb\)](#)

Drawings

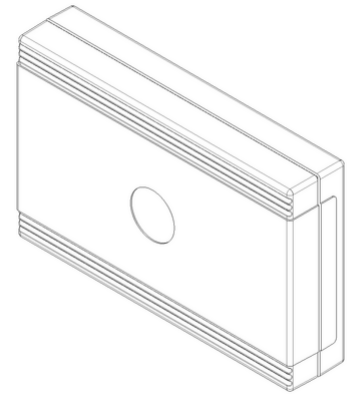
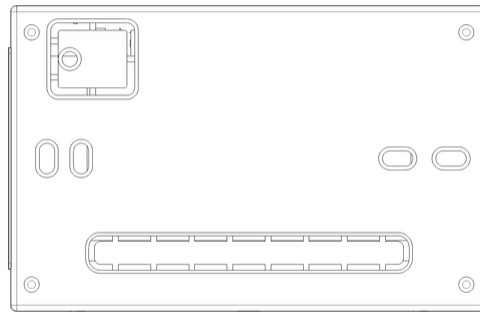
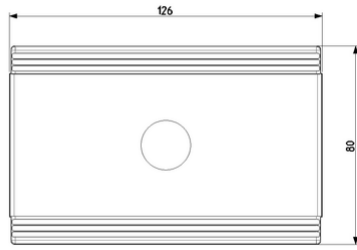

Space view

Backside view

3D View

Certifications

- 00. CE Marking - EU
- 37. Marking - Morocco
- 46. UK PSTI compliance ([download](#))
- 99. WEEE Directive ([download](#))

Technical data

Class group: Alarm installations, emergency call and signalling

Class: Expansion module for danger detection system

Model: Other

Mounting method: Built-in

Housing material: Aluminium

Colour: Brown

Height: 80,00 mm

Width: 126,00 mm

Depth: 27,00 mm

Packaging



8 007352 707979

8007352707979

Qtà 1 NR
Dim 14.4x9x6 [cm]
Weight 156.65 [g]



8 007352 707986

8007352707986

Qtà 15 NR
Dim 29x24.5x14 [cm]
Weight 1,875 [g]



8 007352 726482

8007352726482

Qtà 16 NR
Dim 37.5x30x13.5 [cm]
Weight 2,833 [g]

You may also be interested in



03808 - By-alarm Plus
extension board 5 In/Out



01732.E - By-alarm cable
2x0,22 LSZH Eca 100m



01733.E - By-alarm
cable2x0,5+2x0,22 LSZH
Eca 100m



01734.E - By-alarm
cable2x0,5+4x0,22 LSZH
Eca 100m



01735.E - By-alarm
cable2x0,5+6x0,22 LSZH
Eca 100m

Legal

Vimar reserves the right to change at any time and without notice the characteristics of the products reported. Installation should be carried out by qualified staff in compliance with the current regulations regarding the installation of electrical equipment in the country where the products are installed. For the terms of use of the information on the product info sheet see [Conditions of Use](#).