



NEVE UP: Button 1M flame symbol carbon matt

09021.H.CM

Wiring devices / Traditional wiring devices / NEVE UP / Devices

Button 1M flame symbol carbon matt

1-module interchangeable button, lightTable flame symbol, carbon matt

Product Status

3 - Active

Minimum order quantity

50 NR

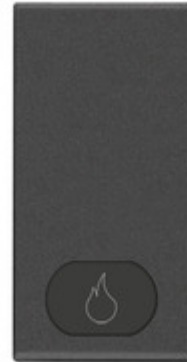

Drawings

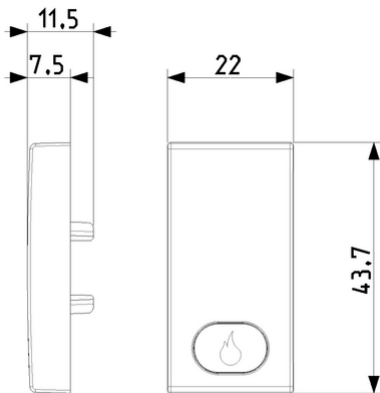

Space view

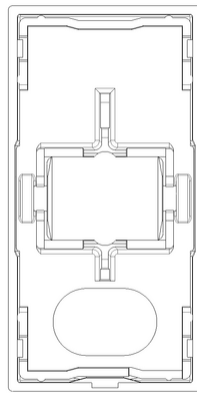

Backside view

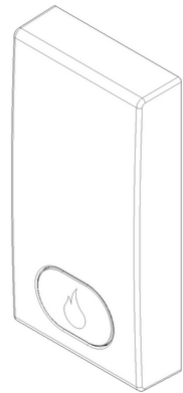

3D View

Certifications

- 00. CE Marking - EU

Technical data

Class group: Domestic switching devices

Class: Control element/cover plate for domestic switching devices

Model: One-part rocker

Utilization: Switch/push button

Suitable for touch sensor connector for bus system: No

Type of fastening: Clamp mounting

Monitoring window/light outlet: Yes

Material: Plastic

Material quality: Thermoplastic

Surface protection: Lacquered

Surface finishing: Glossy

Colour: Anthracite

RAL-number (similar): 7016

With exchangeable lens/symbol: Yes

Width: 22,00 mm

Height: 43,70 mm

Depth: 11,50 mm

Packaging



8007352659339

Qtà 1 NR

Dim 2.2x4.4x1.1 [cm]

Weight 6.326 [g]



8007352659346

Qtà 5 NR

Dim 5.1x2.8x5.3 [cm]

Weight 24.06 [g]



8007352659353

Qtà 50 NR

Dim 14.4x11.6x6 [cm]

Weight 281.3 [g]



8007352668737

Qtà 600 NR

Dim 36.5x33x13.5 [cm]

Weight 3,795.6 [g]

You may also be interested in



09005.0.250 - 1P 16AX 2-
way switch
mechan.+pilot250V



09008.0.12 - 1P NO 10A
push button
mechan.+pilot 12V



09008.0.250 - 1P NO 10A
push button
mechan.+pilot 250V



09021.H.CM - Button 1M
flame symbol carbon
matt

Legal

Vimar reserves the right to change at any time and without notice the characteristics of the products reported. Installation should be carried out by qualified staff in compliance with the current regulations regarding the installation of electrical equipment in the country where the products are installed. For the terms of use of the information on the product info sheet see [Conditions of Use](#).