



NEVE UP: Two interlocked 1P NO+NO 10A pushes w

09062

Wiring devices / Traditional wiring devices / NEVE UP / Devices

Two interlocked 1P NO+NO 10A pushes w

Two 1P NO + 1P NO 10 A 250 V~ interlocked push buttons, with directional arrows, white

Product Status

3 - Active

Minimum order quantity

20 NR



Drawings

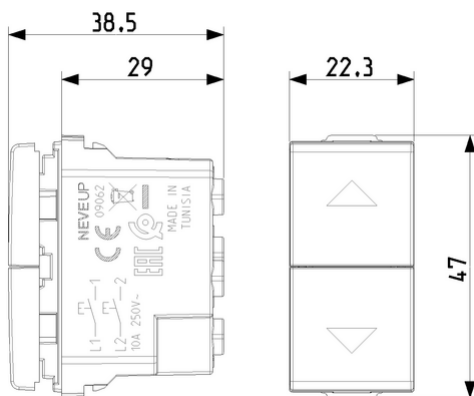

Space view

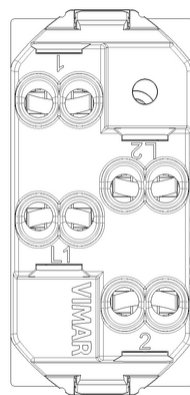

Backside view

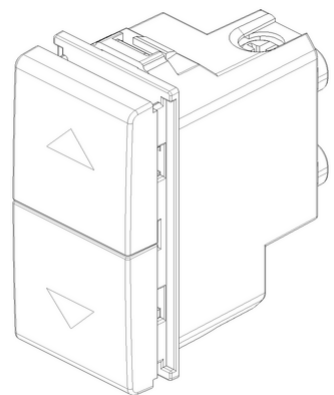

3D View

Certifications

- 00. CE Marking - EU
- 07. INGCER - Chile
- 13. SNI-MGI - Indonesia
- 15. CCC - China ([download](#))
- 19. NOM - Mexico
- 37. Marking - Morocco
- 37. Marking - Morocco
- 96. Electrotechnical expert ([download](#))
- 99. WEEE Directive ([download](#))

Technical data

Class group: Domestic switching devices

Class: Push button

Assembly arrangement: Modular device for domestic switching devices

Model: Other

Operating method: Push button

Number of rockers: 1

Number of modules (module system): 100

Number of poles: 1

Nominal voltage: 250 V

Rated current: 10,00 A

With lighting: No

Monitoring contact: No

Mounting method: Built-in

Type of fastening: Engage (snap)

Material: Plastic

Material quality: Thermoplastic

Halogen free: Yes

Surface protection: Untreated

Surface finishing: Glossy

Colour: White

RAL-number (similar): 9003

Transparent: No

Label space/information surface: Yes

Suitable for degree of protection (IP): IP40

Device width: 22,30 mm

Device height: 47,00 mm

Device depth: 38,50 mm

Packaging



8 007352 416741

8007352416741

Qtà 1 NR
Dim 4.1x2.8x5.3 [cm]
Weight 31.8 [g]



8 007352 416758

8007352416758

Qtà 20 NR
Dim 21.4x11.6x6 [cm]
Weight 691.2 [g]



8 007352 665781

8007352665781

Qtà 200 NR
Dim 30.5x25.5x22.5 [cm]
Weight 7,255 [g]

You may also be interested in



09060 - 2P 10AX switch
white

Legal

Vimar reserves the right to change at any time and without notice the characteristics of the products reported. Installation should be carried out by qualified staff in compliance with the current regulations regarding the installation of electrical equipment in the country where the products are installed. For the terms of use of the information on the product info sheet see [Conditions of Use](#).