



PLANA: 1P 10AX 2-way 2M switch screwless white

14004.FX.2

Wiring devices / Traditional wiring devices / PLANA / Devices

1P 10AX 2-way 2M switch screwless white

1P 10 AX 250 V~ 2-way switch, screwless terminals, lightable, replaceable button, white - 2 modules. Max 100 W for self-ballasted lamps (IEC 60669-1:2017)

Product Status

3 - Active

Minimum order quantity

20 NR



Drawings

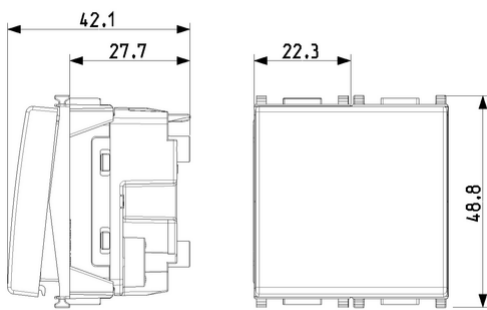

Space view

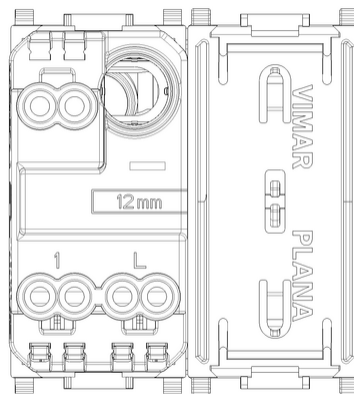

Backside view

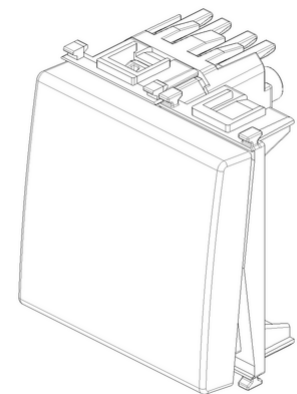

3D View

Certifications

- 00. CE Marking - EU
- 04. NF - France ([download](#))
- 09. VDE - Germany ([download](#))
- 31. TISI - Thailand
- 37. Marking - Morocco
- 96. Electrotechnical expert ([download](#))
- 99. WEEE Directive ([download](#))

Technical data

Class group: Domestic switching devices

Class: Installation switch

Wiring system: Two-way switch

Operating method: Rocker/button

Assembly arrangement: Modular device for domestic switching devices

Number of modules (module system): 2

Push button switch: Yes

Number of rockers: 1

Mounting method: Flush-mounted

Type of fastening: Engage (snap)

With mounting plate: No

Material: Plastic

Material quality: Thermoplastic

Halogen free: Yes

Surface protection: Untreated

Surface finishing: Glossy

Colour: White

RAL-number (similar): 9003

Label space/information surface: Yes

Lighting: Optional

Function lighting: Control and orientation

Type of lighting: LED exchangeable

Suitable for degree of protection (IP): IP40

Nominal voltage: 250 V

Rated current: 10,00 A

Monitoring contact: No

Connection type: Push-in clamp

Washing machine switch: No

Device width: 44,80 mm

Device height: 49,00 mm

Device depth: 42,10 mm

Built-in depth: 27,70 mm

Packaging



8007352513914

Qtà 1 NR

Dim 5.1x4.3x5.3 [cm]

Weight 37.1 [g]



8007352513921

Qtà 20 NR

Dim 26.9x11.6x9 [cm]

Weight 820.7 [g]

Legal

Vimar reserves the right to change at any time and without notice the characteristics of the products reported. Installation should be carried out by qualified staff in compliance with the current regulations regarding the installation of electrical equipment in the country where the products are installed. For the terms of use of the information on the product info sheet see [Conditions of Use](#).