



PLANA: 1P NO 10A pushbutton bell symb.2M Silver

14008.2.C.SL

Wiring devices / Traditional wiring devices / PLANA / Devices

1P NO 10A pushbutton bell symb.2M Silver

1P NO 10 A 250 V~ push button, bell symbol, lightable, replaceable button, Silver - 2 modules

Product Status

3 - Active

Minimum order quantity

20 NR



Drawings

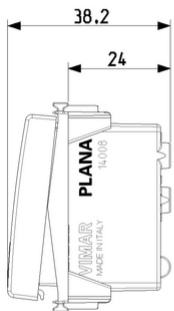

Space view

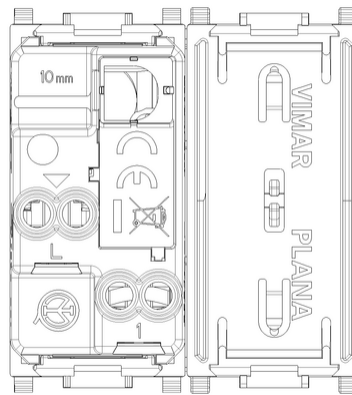
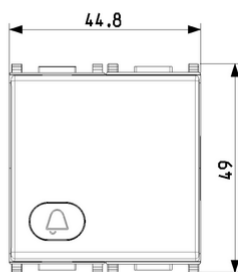

Backside view

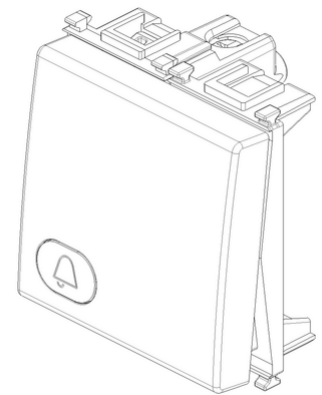

3D View

Certifications

- 00. CE Marking - EU
- 01. IMQ - Italy
- 13. SNI-MGI - Indonesia
- 14. TSE - Turkey
- 15. CCC - China ([download](#))
- 19. NOM - Mexico
- 26. SASO - Saudi Arabia ([download](#))
- 31. TISI - Thailand
- 35. RCM - Australia
- 37. Marking - Morocco
- 96. Electrotechnical expert ([download](#))
- 99. WEEE Directive ([download](#))

Technical data

Class group: Domestic switching devices

Class: Push button

Assembly arrangement: Modular device for domestic switching devices

Model: Single push button

Operating method: Push button

Number of rockers: 1

Number of modules (module system): 200

Number of poles: 1

Nominal voltage: 250 V

Rated current: 10,00 A

With lighting: Yes

Monitoring contact: No

Mounting method: Built-in

Type of fastening: Engage (snap)

Material: Plastic

Material quality: Thermoplastic

Halogen free: Yes

Surface protection: Lacquered

Surface finishing: Glossy

Colour: Silver

RAL-number (similar): 9006

Transparent: No

Label space/information surface: Yes

Suitable for degree of protection (IP): IP40

Device width: 44,80 mm

Device height: 49,00 mm

Device depth: 38,20 mm

Packaging



8007352320055

Qtà 1 NR

Dim 5.1x4.3x5.3 [cm]

Weight 35.93 [g]



8007352320062

Qtà 20 NR

Dim 26.9x11.6x9 [cm]

Weight 798.27 [g]

Legal

Vimar reserves the right to change at any time and without notice the characteristics of the products reported. Installation should be carried out by qualified staff in compliance with the current regulations regarding the installation of electrical equipment in the country where the products are installed. For the terms of use of the information on the product info sheet see [Conditions of Use](#).