



PLANA: Button 2M lightable ring pilot white

14022

Wiring devices / Traditional wiring devices / PLANA / Buttons

Button 2M lightable ring pilot white

Interchangeable 2-module button, with lightable ring pilot lamp, white

Product Status

3 - Active

Minimum order quantity

20 NR



Drawings

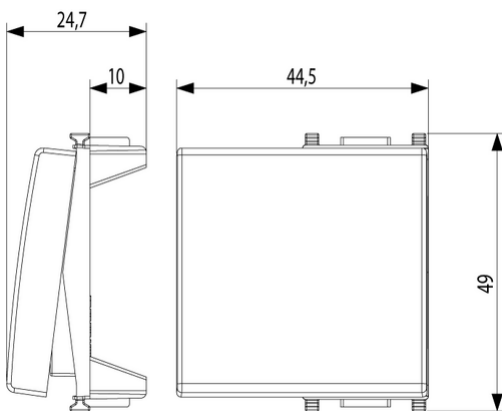

Space view

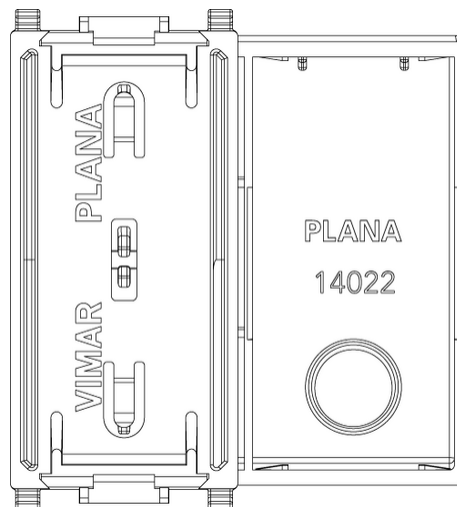

Backside view

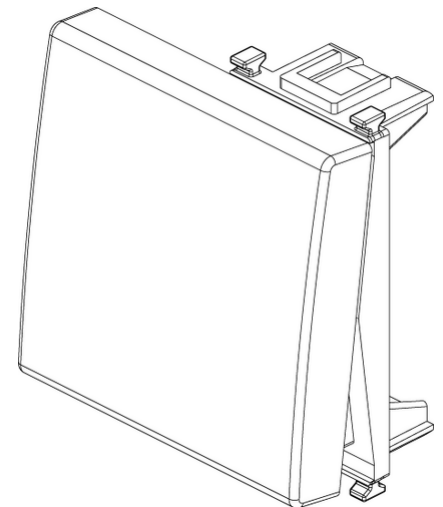

3D View

Certifications

- 00. CE Marking - EU
- 01. IMQ - Italy ([download](#))
- 96. Electrotechnical expert ([download](#))

Technical data

Class group: Domestic switching devices

Class: Control element/cover plate for domestic switching devices

Model: One-part rocker

Imprint/indication: None

Utilization: Switch/push button

Suitable for touch sensor connector for bus system: No

Type of fastening: Clamp mounting

Monitoring window/light outlet: Yes

Material: Plastic

Material quality: Thermoplastic

Halogen free: Yes

Surface protection: Untreated

Surface finishing: Glossy

Colour: White

RAL-number (similar): 9003

With label area: No

With exchangeable lens/symbol: No

Suitable for degree of protection (IP): IP40

Depth: 1.470,00 mm

Packaging



8007352112407

Qtà 1 NR

Dim 4.9x4.5x2.5 [cm]

Weight 10.4 [g]



8007352112414

Qtà 2 NR

Dim 5.1x2.8x5.3 [cm]

Weight 24.87 [g]



8007352112421

Qtà 20 NR

Dim 14.4x11.6x6 [cm]

Weight 290.47 [g]



8007352626041

Qtà 240 NR

Dim 36.5x33x13.5 [cm]

Weight 3,905 [g]

Legal

Vimar reserves the right to change at any time and without notice the characteristics of the products reported. Installation should be carried out by qualified staff in compliance with the current regulations regarding the installation of electrical equipment in the country where the products are installed. For the terms of use of the information on the product info sheet see [Conditions of Use](#).