



PLANA: Dimmer 230V 100-500W white

14150

Wiring devices / Traditional wiring devices / PLANA / Devices

Dimmer 230V 100-500W white

Dimmer, 230 V~ 50-60 Hz, for: 100-500 W incandescent lamps, control and regulation by rotary potentiometer, visible in darkness, white

Product Status

3 - Active

Minimum order quantity

20 NR



Sheets, Manuals, Documentation

- [Multilanguage instructions sheet \(626 kb\)](#)

Drawings

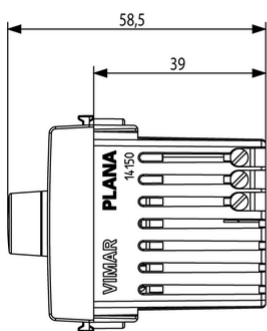

Space view

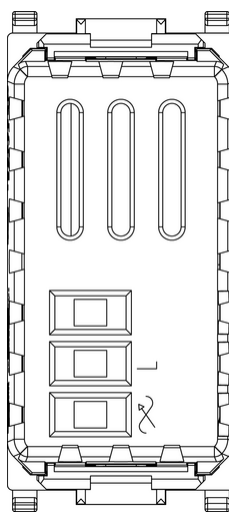
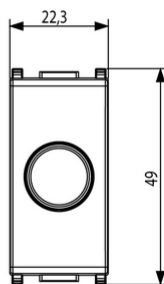

Backside view

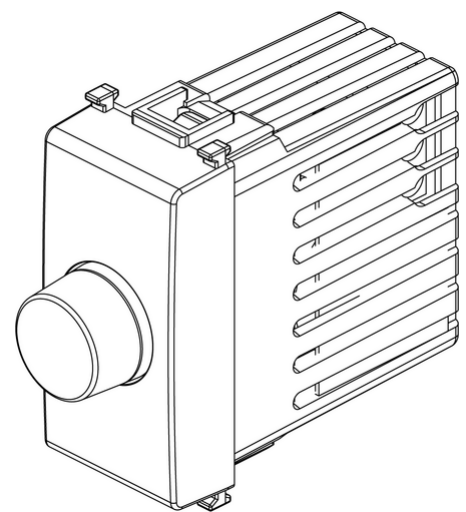

3D View

Certifications

- 00. CE Marking - EU
- 01. IMQ - Italy ([download](#))
- 37. Marking - Morocco
- 96. Electrotechnical expert ([download](#))
- 99. WEEE Directive ([download](#))

Technical data

Class group: Domestic switching devices

Class: Dimmer

Operating method: Turn button

Type of load: Resistive load

Applicable with button: No

Applicable with movement sensor: No

Applicable with presence indicator: No

Applicable with time switch/timer: No

Applicable with transmission button: No

Applicable with infrared button: No

Mounting method: Flush-mounted

Type of fastening: Click in mounting

Material: Plastic

Material quality: Thermoplastic

Surface protection: Untreated

Surface finishing: Glossy

Colour: White

RAL-number (similar): 9003

Transparent: No

Suitable for degree of protection (IP): IP40

Nominal voltage: 230,00 - 230,01 V

Frequency: 50,00 - 60,00 HZ

Control voltage: 230,00 - 230,01 V

Device width: 22,30 mm

Device height: 49,00 mm

Device depth: 58,50 mm

Packaging



8007352117501

Qtà 1 NR

Dim 6x2.8x5.3 [cm]

Weight 60.97 [g]



8007352117518

Qtà 20 NR

Dim 28.1x13.1x6 [cm]

Weight 1,285.33 [g]

Legal

Vimar reserves the right to change at any time and without notice the characteristics of the products reported. Installation should be carried out by qualified staff in compliance with the current regulations regarding the installation of electrical equipment in the country where the products are installed. For the terms of use of the information on the product info sheet see [Conditions of Use](#).