



PLANA: 5V 2,1A USB supply unit 2M Silver

14295.SL

Wiring devices / Traditional wiring devices / PLANA / Devices

5V 2,1A USB supply unit 2M Silver

5 V 2,1 A power supply unit for electronic devices, 2 USB ports supply a total of 2,1 A suitable for recharging a 2,1 A single device (e.g. Tablet) or two 1 A devices simultaneously (e.g. smartphone and phablet), supply voltage 120-230 V~ 50/60 Hz, Silver



Product Status

2 - Will be discontinued

Minimum order quantity

1 NR

Sheets, Manuals, Documentation

- [pdf Prese USB \(391 kb\)](#)
- [Multilanguage instructions sheet \(1186 kb\)](#)

Gallery



Drawings

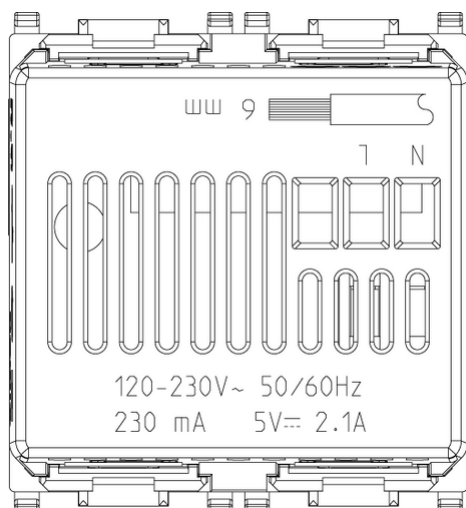

Backside view

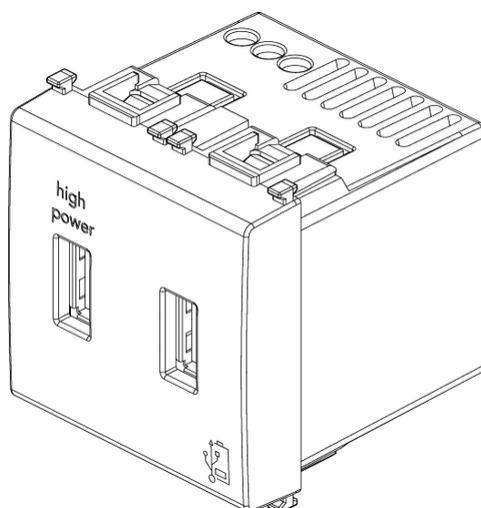

3D View

Certifications

- 00. CE Marking - EU
- 37. Marking - Morocco
- 96. Electrotechnical expert ([download](#))
- 99. WEEE Directive ([download](#))

Technical data

Class group: Domestic switching devices

Class: USB power supply

Model: Bus

Operating voltage: 120,00 - 230,00 V

Frequency: 50,00 - 60,00 HZ

Max. output current: 2.100 mA

Mounting method: Flush-mounted

Colour: Silver

RAL-number: 0

Packaging



8 007352 538832
8007352538832

Qtà 1 NR

Dim 5x5.4x5.3 [cm]

Weight 67.9 [g]



8 007352 538849
8007352538849

Qtà 10 NR

Dim 28.1x13.1x6 [cm]

Weight 759.5 [g]



8 007352 641488
8007352641488

Qtà 120 NR

Dim 38.5x29x30 [cm]

Weight 9,588 [g]

Legal

Vimar reserves the right to change at any time and without notice the characteristics of the products reported. Installation should be carried out by qualified staff in compliance with the current regulations regarding the installation of electrical equipment in the country where the products are installed. For the terms of use of the information on the product info sheet see [Conditions of Use](#).