



PLANA: RJ45 Infra+ adaptor white

14341.C

System infrastructure / Netsafe structured wiring / PLANA /
Devices

RJ45 Infra+ adaptor white

Adaptor for Cat. 5e and 6 modules of Slim series of Infra+, Merlin
Gerin, white

Product Status

3 - Active

Minimum order quantity

20 NR



Drawings

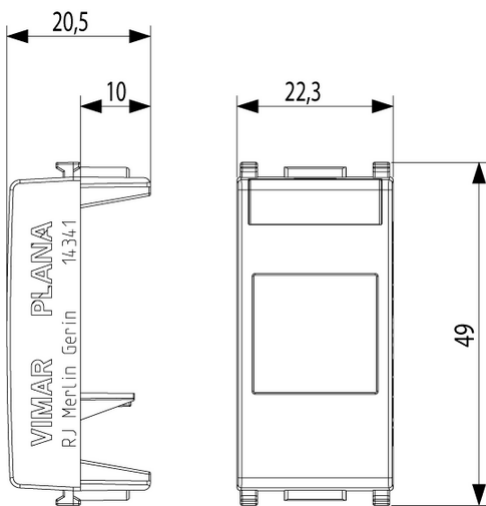

Space view

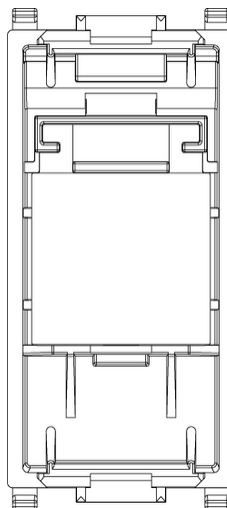

Backside view

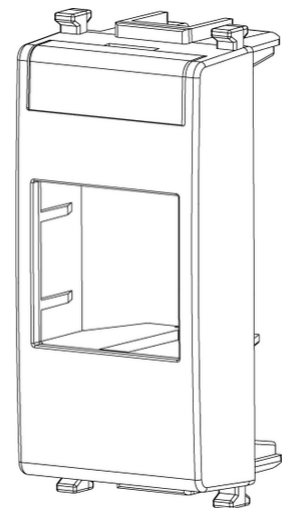

3D View

Technical data

Class group: Domestic switching devices

Class: Transition adaptor for domestic switching devices

Colour: White

RAL-number (similar): 9003

With hinged lid: No

With label space: Yes

Device width: 22,30 mm

Device height: 49,00 mm

Device depth: 20,50 mm

Packaging



8007352152267

Qtà 1 NR

Dim 2.23x4.9x2.05 [cm]

Weight 5.4 [g]



8007352152274

Qtà 2 NR

Dim 4.1x2.8x5.3 [cm]

Weight 14.2 [g]



8007352152281

Qtà 20 NR

Dim 14.4x9x6 [cm]

Weight 176.73 [g]

Legal

Vimar reserves the right to change at any time and without notice the characteristics of the products reported. Installation should be carried out by qualified staff in compliance with the current regulations regarding the installation of electrical equipment in the country where the products are installed. For the terms of use of the information on the product info sheet see [Conditions of Use](#).