



PLANA: 2-way switch IoT connected mechanism

14592.0

Wiring devices / View Wireless wiring devices / PLANA / Devices

2-way switch IoT connected mechanism

View Wireless connected electronic switch mechanism with 100-240 V 50/60 Hz relay output for 500 W incandescent lamps, 100 W LED lamps, 250 VA electronic transformers, 120 W fluorescent lamps, local or remote control, double technology with Bluetooth® wireless technology 5.0 standard for the creation of View Wireless mesh system and Zigbee 3.0 standard, 1 input for external button for actuator control or to recall a scenario, RGB LED visible in darkness with brightness control, 100-240 V 50/60 Hz power supply, to be completed with 1-, 2- or 3-module Plana interchangeable buttons

- Configuration from View Wireless App for Bluetooth technology system and Amazon App for Zigbee technology
- Compatible with Alexa, Google Home and IFTTT, using the dedicated gateway or Zigbee hub

Product Status

3 - Active

Minimum order quantity

1 NR



Sheets, Manuals, Documentation

- [Light multilanguage instructions sheet \(1220 kb\)](#)
- [Foglio istruzioni Full \(776 kb\)](#)
- [Feuille d'instructions Full \(777 kb\)](#)
- [Hoja de instrucciones Full \(775 kb\)](#)
- [Full instructions sheet \(772 kb\)](#)
- [Φυλλάδιο οδηγιών Full \(919 kb\)](#)
- [Anweisungsblatt Full \(777 kb\)](#)
- [Anweisungsblatt Full \(844 kb\)](#)
- [Manuale app View Wireless \(20721 kb\)](#)
- [Manuel appli View Wireless \(43519 kb\)](#)
- [Manual app View Wireless \(43518 kb\)](#)
- [Manual View Wireless app \(43636 kb\)](#)
- [Εγχειρίδιο τεχνικού εγκατάστασης \(43800 kb\)](#)
- [Installationsanleitung View Wireless \(43586 kb\)](#)

Drawings

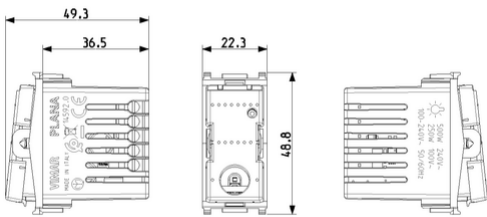

Space view

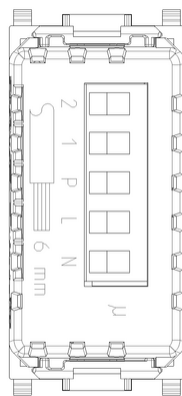

Backside view

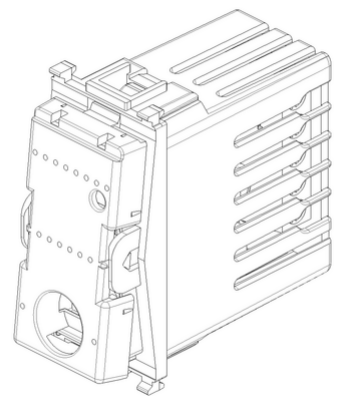

3D View

Certifications

- 00. CE Marking - EU ([download](#))
- 01. IMQ - Italy ([download](#))
- 19. NOM - Mexico
- 37. Marking - Morocco
- 37. Marking - Morocco
- 40. Bluetooth technology
- 42. Zigbee certified
- 46. UK PSTI compliance ([download](#))
- 47. Works with SmartThings
- 92. RoHS UAE
- 96. Electrotechnical expert ([download](#))
- 99. WEEE Directive ([download](#))

Technical data

Class group: Installation bus systems

Class: Switch actuator for bus system

Bus system KNX: No

Bus system KNX-RF (Radio Frequency): No

Bus system radio frequency: Yes

Bus system LON: No

Bus system Powernet: No

Other bus systems: Zigbee

Radio frequency bidirectional: Yes

Mounting method: Surface mounted/flush mounted/built-in

Width in number of modular spacings: 0

Local operation/hand operation: Yes

With LED indication: Yes

Packaging



8007352628328

Qtà 1 NR

Dim 5.2x3.5x5.3 [cm]

Weight 46.6 [g]



8007352628335

Qtà 60 NR

Dim 27x23x12.5 [cm]

Weight 2,998 [g]

You may also be interested in



03925 - Bluetooth Low Energy RF device



14597 - IoT connected gateway 2M white



14597.SL - IoT connected gateway 2M Silver



14021.SL - Button 1M lightable Silver



14021 - Button 1M lightable ring pilot white



14022.SL - Button 2M lightable Silver



14022 - Button 2M lightable ring pilot white

Legal

Vimar reserves the right to change at any time and without notice the characteristics of the products reported. Installation should be carried out by qualified staff in compliance with the current regulations regarding the installation of electrical equipment in the country where the products are installed. For the terms of use of the information on the product info sheet see [Conditions of Use](#).