



PLANA: IoT connected gateway 2M Silver

14597.SL

Wiring devices / View Wireless wiring devices / PLANA / Devices

IoT connected gateway 2M Silver

View Wireless gateway, Bluetooth® wireless technology 4.2 Wi-Fi, RGB LED, 100-240 V 50/60 Hz power supply, Silver - 2 modules

- Configuration from View Wireless App for Bluetooth technology system and Amazon App for Zigbee technology



Product Status

2 - Will be discontinued

Minimum order quantity

1 NR

Sheets, Manuals, Documentation

- [Full multilanguage instructions sheet \(821 kb\)](#)
- [Light multilanguage instructions sheet \(726 kb\)](#)
- [Manuale app View Wireless \(20721 kb\)](#)
- [Manuel appli View Wireless \(43519 kb\)](#)
- [Manual app View Wireless \(43518 kb\)](#)
- [Manual View Wireless app \(43636 kb\)](#)
- [Εγχειρίδιο τεχνικού εγκατάστασης \(43800 kb\)](#)
- [Installationsanleitung View Wireless \(43586 kb\)](#)

Drawings

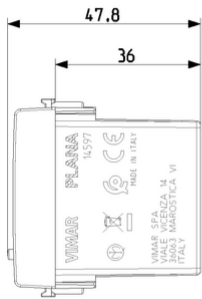

Space view

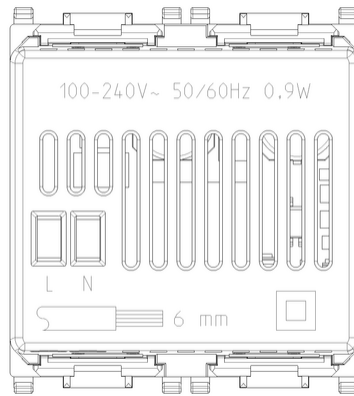
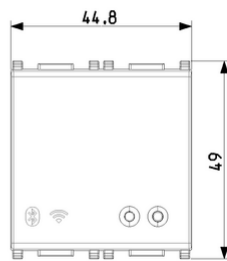

Backside view

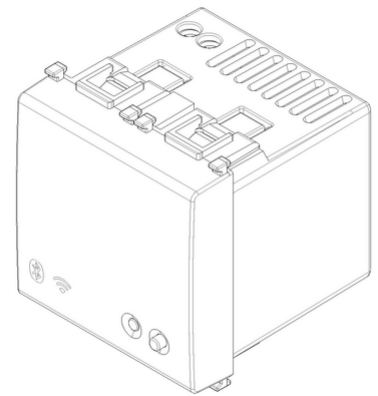

3D View

Certifications

- 00. CE Marking - EU ([download](#))
- 01. IMQ - Italy ([download](#))
- 19. NOM - Mexico
- 37. Marking - Morocco
- 40. Bluetooth technology
- 41. Wi-Fi CERTIFIED ([download](#))
- 46. UK PSTI compliance ([download](#))
- 96. Electrotechnical expert ([download](#))
- 99. WEEE Directive ([download](#))

Technical data

Class group: Installation bus systems

Class: System interface/media gateway for bus system

Bus system KNX: No

Bus system KNX-RF (Radio Frequency): No

Bus system radio frequency: Yes

Bus system LON: No

Bus system Powernet: No

Other bus systems: Other

Radio frequency bidirectional: Yes

Model: Bluetooth interface

Mounting method: Flush-mounted

Width in number of modular spacings: 2

Demounting protection: No

With LED indication: Yes

Updateable: Yes

Protocol: Other

Provider dependent: No

Visualization: No

Web-Server: Yes

Radio interface: Yes

IR interface: No

Degree of protection (IP): IP40

Packaging



8 007352 628625

8007352628625

Qtà 1 NR

Dim 5.7x5.3x7.7 [cm]

Weight 62.5 [g]



8 007352 746251

8007352746251

Qtà 60 NR

Dim 37.5x30x13.5 [cm]

Weight 4,110 [g]

You may also be interested in



03925 - Bluetooth Low Energy RF device



14594.0 - Rolling shutter IoT connected mechanism



14592.0 - 2-way switch IoT connected mechanism



14593.SL - Connected actuator 16A Silver

Legal

Vimar reserves the right to change at any time and without notice the characteristics of the products reported. Installation should be carried out by qualified staff in compliance with the current regulations regarding the installation of electrical equipment in the country where the products are installed. For the terms of use of the information on the product info sheet see [Conditions of Use](#).