



PLANA: Plate 3M techn. polished gold

14653.24

Wiring devices / Traditional wiring devices / PLANA / Cover plates

Plate 3M techn. polished gold

3-module cover plate, technopolymer, polished gold

Product Status

3 - Active

Minimum order quantity

10 NR



Gallery



Drawings

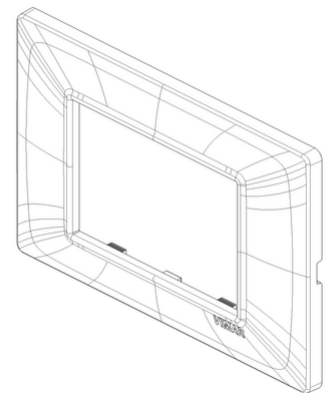
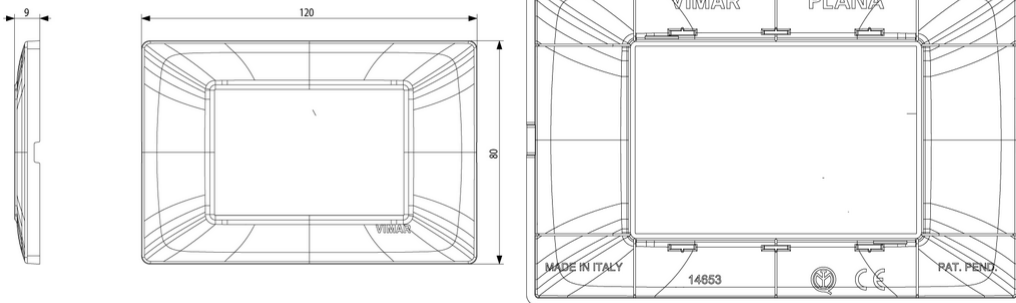

Space view

Backside view

3D View

Certifications

• 00. CE Marking - EU

• 01. IMQ - Italy ([download](#))

Technical data

Class group: Domestic switching devices

Class: Cover frame for domestic switching devices

Number of units: 3

Mounting direction: Horizontal and vertical

Number of device inserts horizontal: 3

Number of device inserts vertical: 1

Number of modules horizontal (module system): 3

Number of modules vertical (module system):
1

With mounting grid: Yes

Suitable for subfloor installation duct box: Yes

Suitable for wall duct: Yes

Suitable for built-in installation: Yes

Label space/information surface: Yes

Material: Plastic

Material quality: Thermoplastic

Halogen free: Yes

Surface protection: Metallic

Surface finishing: Glossy

Colour: Gold

RAL-number (similar): 1036

Transparent: No

With hinged lid: No

Degree of protection (IP): IP00

Type of fastening: Clamp mounting

Width: 120,00 mm

Height: 80,00 mm

Depth: 9,000 mm

Built-in width: 120,00 mm

Built-in height: 80,00 mm

Diameter bore hole (opening): 0,00 mm

Packaging



8007352112018

Qtà 1 NR

Dim 17x8x0.9 [cm]

Weight 19.73 [g]



8007352112025

Qtà 10 NR

Dim 14.1x9.8x9.9 [cm]

Weight 243.53 [g]



8007352629196

Qtà 480 NR

Dim 59x39x31.5 [cm]

Weight 13,559.2 [g]

You may also be interested in



14613 - Frame 3M
+screws

Legal

Vimar reserves the right to change at any time and without notice the characteristics of the products reported. Installation should be carried out by qualified staff in compliance with the current regulations regarding the installation of electrical equipment in the country where the products are installed. For the terms of use of the information on the product info sheet see [Conditions of Use](#).