



PLANA: Plate 4M Reflex snow

14654.41

Wiring devices / Traditional wiring devices / PLANA / Cover plates

Plate 4M Reflex snow

4-module cover plate, technopolymer, Reflex snow

Product Status

3 - Active

Minimum order quantity

10 NR



Gallery



Drawings

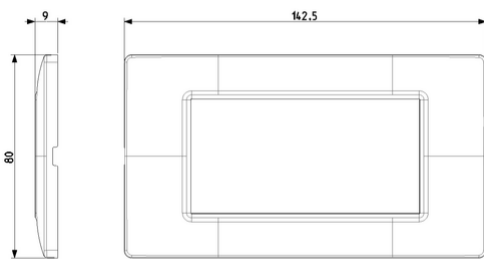

Space view

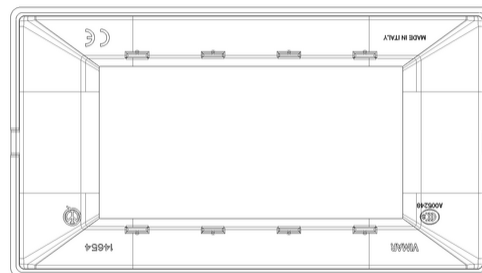

Backside view

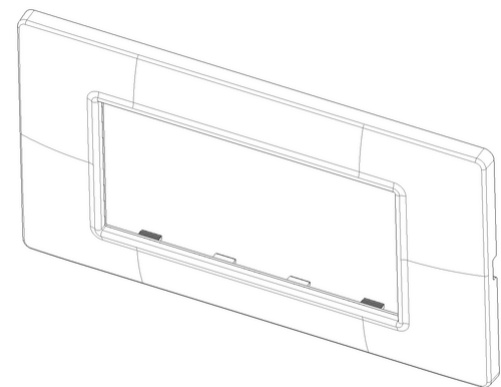

3D View

Certifications

• 00. CE Marking - EU

• 01. IMQ - Italy ([download](#))

Technical data

Class group: Domestic switching devices

Class: Cover frame for domestic switching devices

Number of units: 4

Mounting direction: Horizontal and vertical

Number of device inserts horizontal: 4

Number of device inserts vertical: 1

Number of modules horizontal (module system): 4

Number of modules vertical (module system):
1

With mounting grid: Yes

Suitable for subfloor installation duct box: Yes

Suitable for wall duct: Yes

Suitable for built-in installation: Yes

Label space/information surface: Yes

Material: Plastic

Material quality: Acrylic glass

Halogen free: Yes

Surface protection: Untreated

Surface finishing: Glossy

Colour: White

RAL-number (similar): 9016

Transparent: No

With hinged lid: No

Degree of protection (IP): IP00

Type of fastening: Clamp mounting

Width: 142,50 mm

Height: 80,00 mm

Depth: 9,000 mm

Built-in width: 142,50 mm

Built-in height: 80,00 mm

Diameter bore hole (opening): 0,00 mm

Packaging



8007352122062

Qtà 1 NR

Dim 19x8x0.9 [cm]

Weight 27 [g]



8007352122079

Qtà 10 NR

Dim 17.1x9.8x9.9 [cm]

Weight 324.53 [g]



8007352635227

Qtà 360 NR

Dim 59x34.5x32.5 [cm]

Weight 12,432 [g]

You may also be interested in



14614 - Frame 4M
+screws

Legal

Vimar reserves the right to change at any time and without notice the characteristics of the products reported. Installation should be carried out by qualified staff in compliance with the current regulations regarding the installation of electrical equipment in the country where the products are installed. For the terms of use of the information on the product info sheet see [Conditions of Use](#).