



PLANA: 2 half buttons 2M regulation symb.white

14752.3

Smart systems&products / By-me Plus / PLANA / Buttons

2 half buttons 2M regulation symb.white

Two interchangeable half-buttons, regulation symbol, 2 modules, white

Product Status

3 - Active

Minimum order quantity

1 NR



Drawings

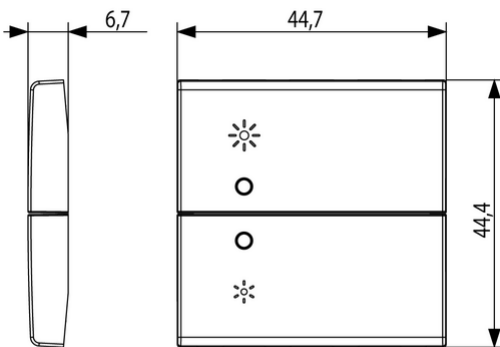

Space view

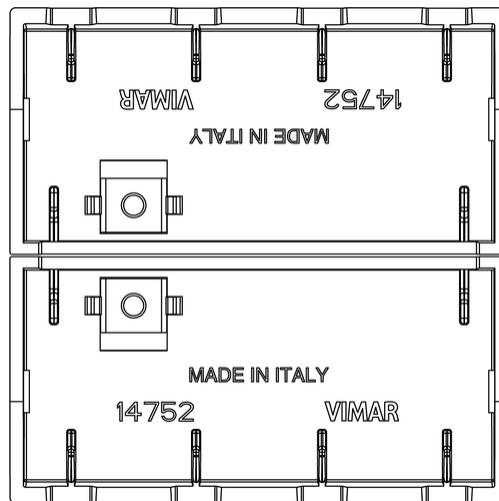

Backside view

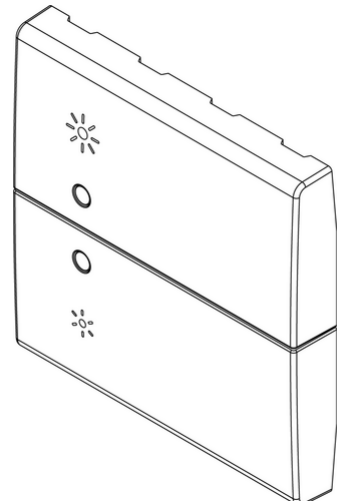

3D View

Certifications

- 00. CE Marking - EU

Technical data

Class group: Installation bus systems

Class: Touch rocker for bus system

Bus system KNX: Yes

Bus system KNX-RF (Radio Frequency): No

Bus system radio frequency: No

Bus system LON: No

Bus system Powernet: No

Other bus systems: Other

Radio frequency bidirectional: No

Material: Plastic

Material quality: Thermoplastic

Surface protection: Untreated

Surface finishing: Glossy

Colour: White

RAL-number (similar): 9003

Transparent: No

Packaging



8007352591349

Qtà 1 NR

Dim 6.5x6x1 [cm]

Weight 6.1 [g]



8007352591356

Qtà 10 NR

Dim 12.3x9.6x5.1 [cm]

Weight 93.5 [g]

Legal

Vimar reserves the right to change at any time and without notice the characteristics of the products reported. Installation should be carried out by qualified staff in compliance with the current regulations regarding the installation of electrical equipment in the country where the products are installed. For the terms of use of the information on the product info sheet see [Conditions of Use](#).