



Protected&watertight series: IP40 enclosure 1M

14801

System infrastructure / Enclosures and control units /
Protected&watertight series / IsoSet - watertight&protected

IP40 enclosure 1M

1-module surface enclosure for Eikon and Plana series, IP40

Product Status

3 - Active

Minimum order quantity

40 NR



Gallery



Drawings

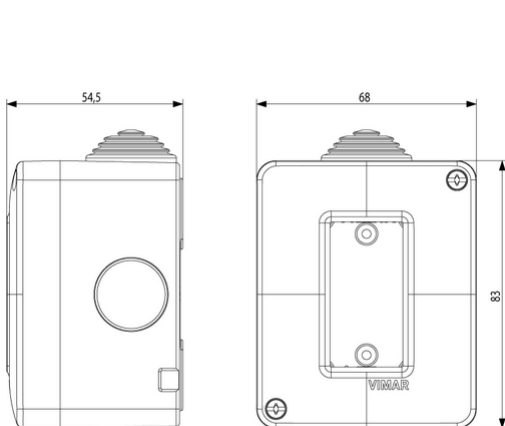

Space view

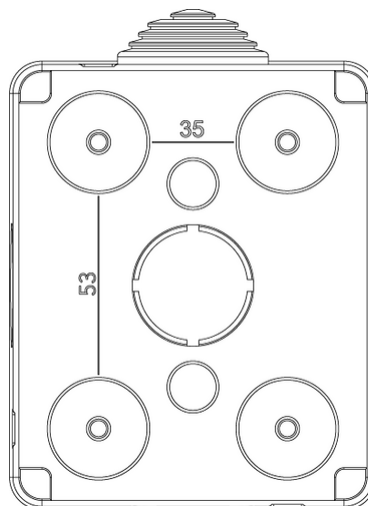

Backside view

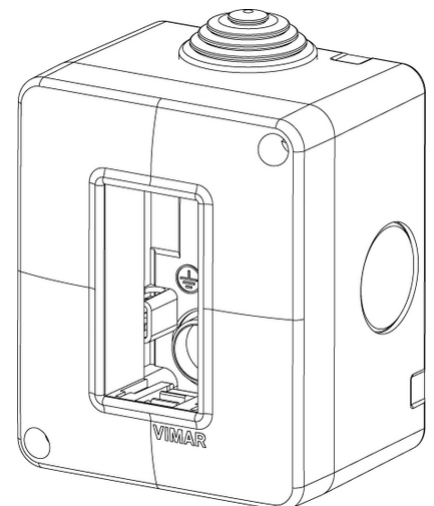

3D View

Certifications

- 00. CE Marking - EU
- 01. IMQ - Italy ([download](#))
- 96. Electrotechnical expert ([download](#))

Technical data

Class group: Electrical installation, isolation and connection material

Class: Equipment carrier for insulated walls

Material: Plastic

Mounting surfaces: Other

With full insulating materials: Yes

Packaging



8007352107977

Qtà 1 NR

Dim 6.8x8.3x5.5 [cm]

Weight 57.96 [g]



8007352107984

Qtà 5 NR

Dim 6.8x8.3x5.5 [cm]

Weight 289.8 [g]



8007352263819

Qtà 40 NR

Dim 35x29x20 [cm]

Weight 2,720.67 [g]

You may also be interested in



14802 - IP40 enclosure
2M



14803 - IP40 enclosure
3M



14804 - IP40 enclosure
4M

Legal

Vimar reserves the right to change at any time and without notice the characteristics of the products reported. Installation should be carried out by qualified staff in compliance with the current regulations regarding the installation of electrical equipment in the country where the products are installed. For the terms of use of the information on the product info sheet see [Condizioni di utilizzo](#).