



IDEA: RJ45 AMP Avaya adaptor white

16358.C.B

System infrastructure / Netsafe structured wiring / IDEA / Devices

RJ45 AMP Avaya adaptor white

Adaptor for RJ45 Cat. 5 connectors: AMP/Tyco (JACK 110 series, Toolless Jack, Jack MTRJ), Lucent Technologies/Avaya/Systimax (MPS100, MGS200, MGS300, MGS400 and MGS500), white

Product Status

3 - Active

Minimum order quantity

20 NR



Drawings

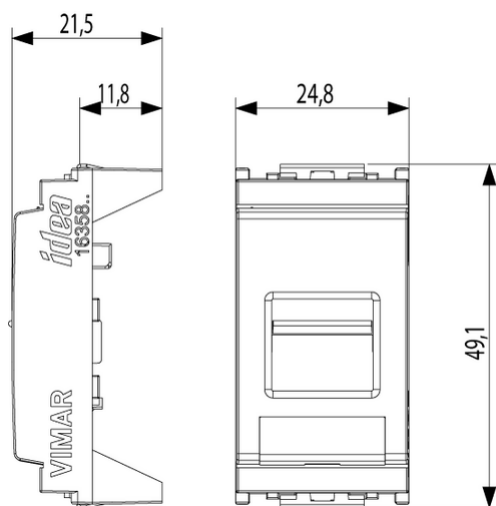

Space view

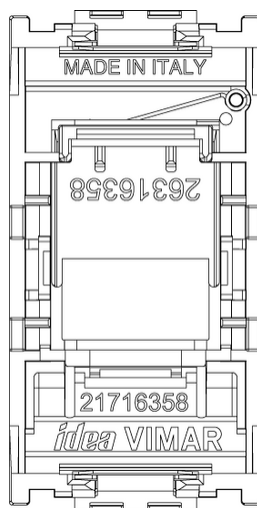

Backside view

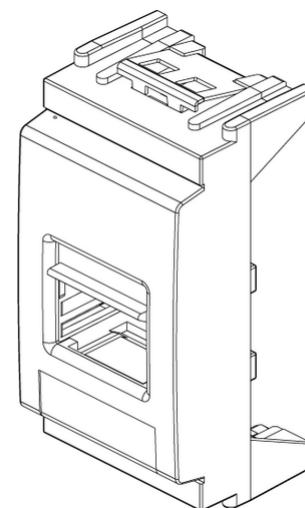

3D View

Technical data

Class group: Domestic switching devices

Class: Transition adaptor for domestic switching devices

Colour: White

RAL-number (similar): 9001

With hinged lid: Yes

With label space: Yes

Device width: 24,80 mm

Device height: 49,10 mm

Device depth: 21,50 mm

Packaging



8007352090248

Qtà 1 NR

Dim 2.5x5x2.1 [cm]

Weight 7.8 [g]



8007352090217

Qtà 2 NR

Dim 6x2.8x5.3 [cm]

Weight 19.87 [g]



8007352090224

Qtà 20 NR

Dim 14.4x13.1x6 [cm]

Weight 248.73 [g]



8007352650183

Qtà 400 NR

Dim 50.5x20x28 [cm]

Weight 5,400 [g]

Legal

Vimar reserves the right to change at any time and without notice the characteristics of the products reported. Installation should be carried out by qualified staff in compliance with the current regulations regarding the installation of electrical equipment in the country where the products are installed. For the terms of use of the information on the product info sheet see [Condizioni di utilizzo](#).