



IDEA: Frame 2M smooth front white

16722.L.B

Wiring devices / Traditional wiring devices / IDEA / Mounting frames

Frame 2M smooth front white

2-module mounting frame, smooth front, without screws, for 3-module and 60 mm fixing centres or 56x56 mm mounting boxes, white

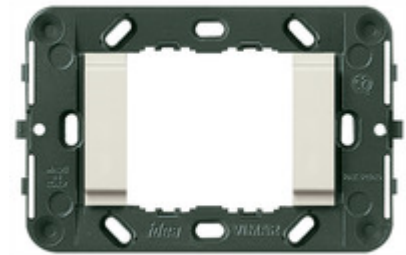

Product Status

3 - Active

Minimum order quantity

20 NR

Drawings

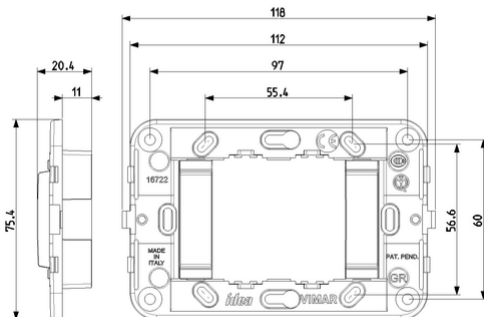

Space view

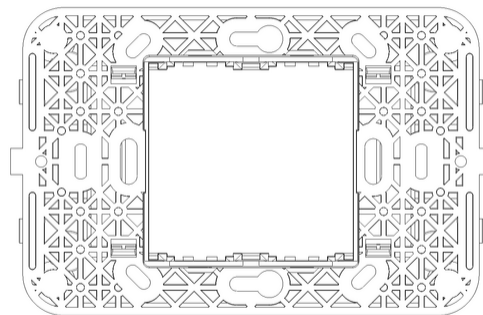

Backside view

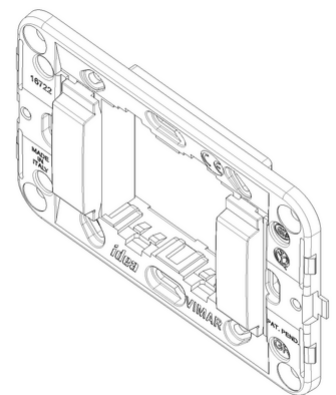

3D View

Certifications

- 00. CE Marking - EU
- 01. IMQ - Italy ([download](#))
- 96. Electrotechnical expert ([download](#))

Technical data

Class group: Domestic switching devices

Class: Holder for modular domestic switching devices

Model: Flush-mounted

Type of fastening: Other

Mounting method of the module inserts: Back side

Mounting direction: Horizontal and vertical

Number of modules horizontal (module system): 2

Number of modules vertical (module system): 1

With built-in installation box: No

With screws: No

Suitable for mounting in round junction box 60 mm: No

Flush-mounted installation: Yes

Suitable for subfloor installation duct box: No

Suitable for wall duct: No

Suitable for mounting on DIN-rail 35 mm: No

Material: Plastic

Material quality: Thermoplastic

Surface protection: Untreated

Packaging



8 007352 117051

8007352117051

Qtà 1 NR

Dim 9.7x6x2 [cm]

Weight 26.2 [g]



8 007352 117068

8007352117068

Qtà 20 NR

Dim 24.4x13.9x11.9 [cm]

Weight 625.4 [g]



8 007352 649132

8007352649132

Qtà 120 NR

Dim 38.5x29.5x25 [cm]

Weight 4,156 [g]

You may also be interested in



[07937 - Screw for frame fixing - 35mm](#)



[07939 - Screw for frame fixing - 50 mm](#)

Legal

Vimar reserves the right to change at any time and without notice the characteristics of the products reported. Installation should be carried out by qualified staff in compliance with the current regulations regarding the installation of electrical equipment in the country where the products are installed. For the terms of use of the information on the product info sheet see [Conditions of Use](#).