



## IDEA: Frame 1M +claws white

### 17081.B

Wiring devices / Traditional wiring devices / IDEA / Mounting frames

### Frame 1M +claws white

1-module mounting frame, grooved front, with claws, for  $\varnothing$  60 mm round flush or 09971 surface mounting boxes, white



### Product Status

3 - Active

### Minimum order quantity

50 NR

## Drawings

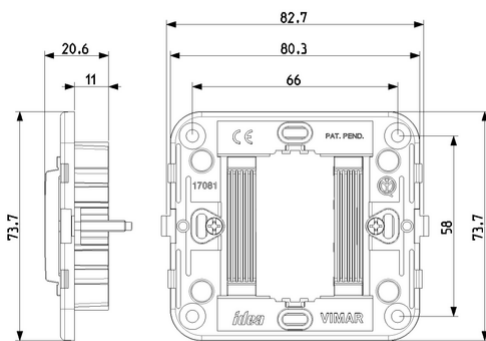

Space view

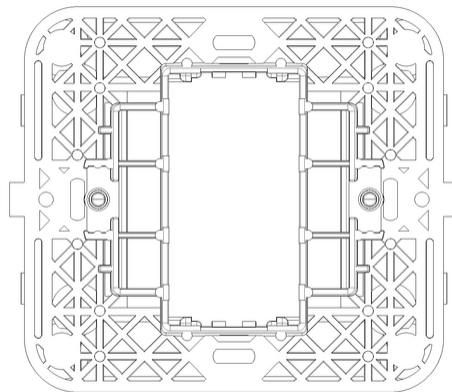

Backside view

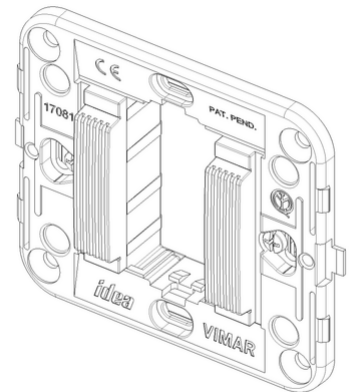

3D View

## Certifications

- 00. CE Marking - EU
- 01. IMQ - Italy ([download](#))
- 96. Electrotechnical expert ([download](#))

## Technical data

**Class group:** Domestic switching devices

**Class:** Holder for modular domestic switching devices

**Model:** Flush-mounted

**Type of fastening:** Other

**Mounting method of the module inserts:** Back side

**Mounting direction:** Horizontal and vertical

**Number of modules horizontal (module system):** 1

**Number of modules vertical (module system):** 1

**With built-in installation box:** No

**With screws:** No

**Suitable for mounting in round junction box 60 mm:** Yes

**Flush-mounted installation:** Yes

**Suitable for subfloor installation duct box:** No

**Suitable for wall duct:** No

**Suitable for mounting on DIN-rail 35 mm:** No

**Material:** Plastic

**Material quality:** Thermoplastic

**Surface protection:** Untreated

## Packaging



8007352065048

**Qtà** 1 NR

**Dim** 8.5x7.5x3 [cm]

**Weight** 30.07 [g]



8007352065055

**Qtà** 50 NR

**Dim** 35.5x24.8x8.7 [cm]

**Weight** 1,659.87 [g]

## Legal

Vimar reserves the right to change at any time and without notice the characteristics of the products reported. Installation should be carried out by qualified staff in compliance with the current regulations regarding the installation of electrical equipment in the country where the products are installed. For the terms of use of the information on the product info sheet see [Conditions of Use](#).