



## ARKÉ: 1P 10AX 1-way switch 2M grey

**19000.2**

Wiring devices / Traditional wiring devices / ARKÉ / Devices

### 1P 10AX 1-way switch 2M grey

1P 10 AX 250 V~ 1-way switch, lightable, replaceable button, grey  
- 2 modules. Max 100 W for lamps with built-in power unit(IEC 60669-1:2017)

### Product Status

3 - Active

### Minimum order quantity

20 NR



## Drawings

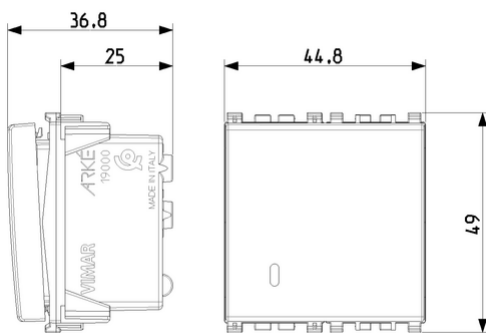

Space view

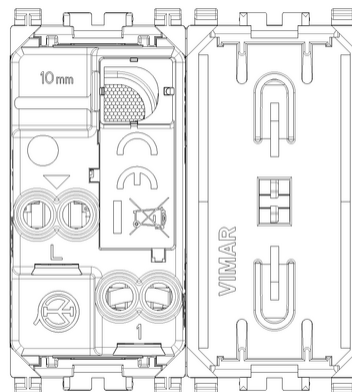

Backside view

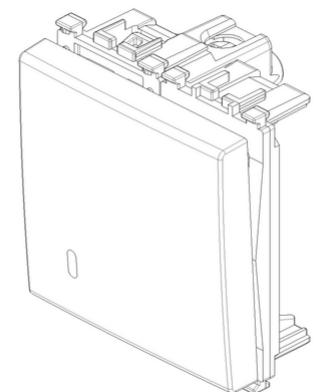

3D View

## Certifications

- 00. CE Marking - EU
- 01. IMQ - Italy ([download](#))
- 15. CCC - China ([download](#))
- 35. RCM - Australia
- 36. ISI - India
- 37. Marking - Morocco
- 37. Marking - Morocco
- 50. Product Environm. Profile
- 92. RoHS UAE
- 96. Electrotechnical expert ([download](#))
- 99. WEEE Directive ([download](#))

## Technical data

**Class group:** Domestic switching devices

**Class:** Installation switch

**Wiring system:** Switch 1-pole

**Operating method:** Rocker/button

**Assembly arrangement:** Modular device for domestic switching devices

**Number of modules (module system):** 2

**Push button switch:** Yes

**Number of rockers:** 1

**Mounting method:** Flush-mounted

**Type of fastening:** Engage (snap)

**With mounting plate:** No

**Material:** Plastic

**Material quality:** Thermoplastic

**Surface protection:** Untreated

**Surface finishing:** Matt

**Colour:** Grey

**RAL-number (similar):** 7015

**Label space/information surface:** Yes

**Lighting:** Optional

**Function lighting:** Control and orientation

**Suitable for degree of protection (IP):** IP40

**Nominal voltage:** 250 V

**Rated current:** 10,00 A

**Monitoring contact:** No

**Connection type:** Screwed terminal

**Washing machine switch:** No

## Packaging



8007352685031

**Qtà** 1 NR

**Dim** 5.1x4.3x5.3 [cm]

**Weight** 34 [g]



8007352685048

**Qtà** 20 NR

**Dim** 26.9x11.6x9 [cm]

**Weight** 767.8 [g]



8007352685055

**Qtà** 240 NR

**Dim** 38x28.5x35.5 [cm]

**Weight** 9,756 [g]

## Legal

Vimar reserves the right to change at any time and without notice the characteristics of the products reported. Installation should be carried out by qualified staff in compliance with the current regulations regarding the installation of electrical equipment in the country where the products are installed. For the terms of use of the information on the product info sheet see [Conditions of Use](#).