



## ARKÉ: 1P 10AX 1-way switch screwless white

### 19000.FX.B

Wiring devices / Traditional wiring devices / ARKÉ / Devices

### 1P 10AX 1-way switch screwless white

1P 10 AX 250 V~ 1-way switch, screwless terminals, screwless terminals, lighTable, replaceable button, white. Max 100 W for self-ballasted lamps (IEC 60669-1:2017)

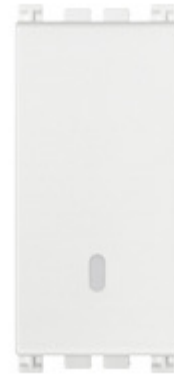

### Product Status

3 - Active

### Minimum order quantity

1 NR

## Drawings

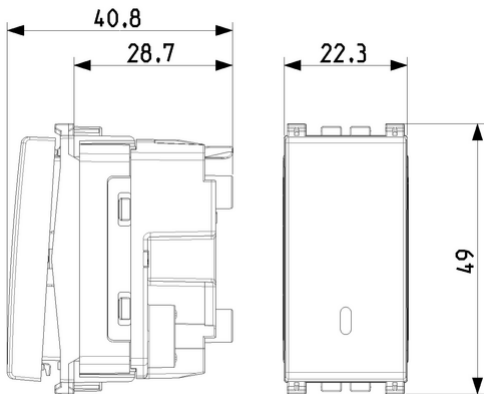

Space view

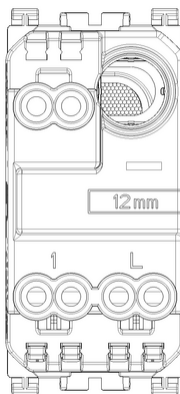

Backside view

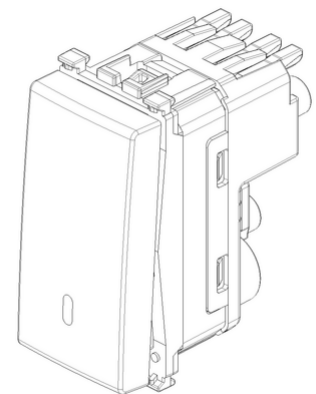

3D View

## Certifications

- 00. CE Marking - EU
- 04. NF - France ([download](#))
- 09. VDE - Germany ([download](#))
- 37. Marking - Morocco
- 99. WEEE Directive ([download](#))

## Technical data

**Class group:** Domestic switching devices

**Class:** Installation switch

**Wiring system:** Switch 1-pole

**Operating method:** Rocker/button

**Assembly arrangement:** Modular device for domestic switching devices

**Number of modules (module system):** 1

**Push button switch:** Yes

**Number of rockers:** 1

**Mounting method:** Flush-mounted

**Type of fastening:** Engage (snap)

**With mounting plate:** No

**Material:** Plastic

**Material quality:** Thermoplastic

**Halogen free:** Yes

**Surface protection:** Untreated

**Surface finishing:** Matt

**Colour:** White

**RAL-number (similar):** 9016

**Label space/information surface:** Yes

**Lighting:** Optional

**Function lighting:** Control and orientation

**Type of lighting:** LED exchangeable

**Suitable for degree of protection (IP):** IP40

**Nominal voltage:** 250 V

**Rated current:** 10,00 A

**Switching current for fluorescent lamps:** 10

**Monitoring contact:** No

**Connection type:** Push-in clamp

**Washing machine switch:** No

**Device width:** 22,30 mm

**Device height:** 49,00 mm

**Device depth:** 38,30 mm

**Built-in depth:** 26,90 mm

## Packaging



8 007352 629752

8007352629752

**Qtà** 1 NR

**Dim** 5.1x2.8x5.3 [cm]

**Weight** 25 [g]



8 007352 629769

8007352629769

**Qtà** 50 NR

**Dim** 27x15x12 [cm]

**Weight** 1,346 [g]

## Legal

Vimar reserves the right to change at any time and without notice the characteristics of the products reported. Installation should be carried out by qualified staff in compliance with the current regulations regarding the installation of electrical equipment in the country where the products are installed. For the terms of use of the information on the product info sheet see [Condizioni di utilizzo](#).