



EIKON: 1P 16AX reversing switch white

20013.B

Wiring devices / Traditional wiring devices / EIKON / Devices

1P 16AX reversing switch white

1P 16 AX 250 V~ reversing switch, lightable, replaceable button, white. Max 200 W for self-ballasted lamps (IEC 60669-1:2017)

Product Status

3 - Active

Minimum order quantity

50 NR



Drawings

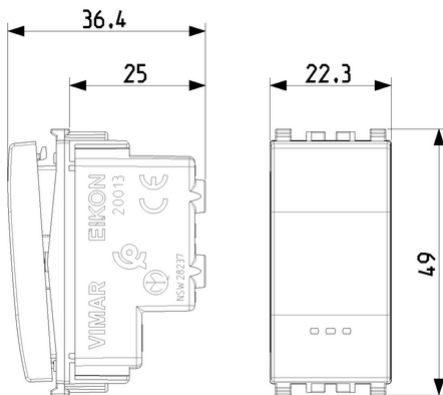

Space view

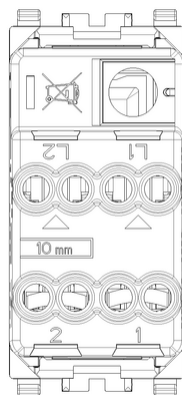

Backside view

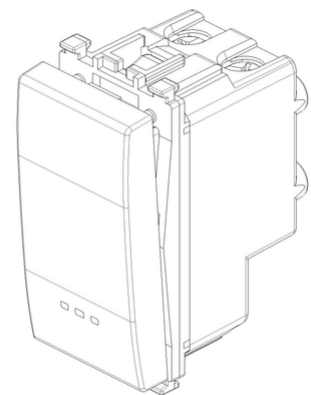

3D View

Certifications

- 00. CE Marking - EU
- 01. IMQ - Italy ([download](#))
- 11. SNI-SUCOFINDO Indonesia
- 13. SNI-MGI - Indonesia
- 14. TSE - Turkey
- 15. CCC - China ([download](#))
- 19. NOM - Mexico
- 20. IQC - Argentina
- 31. TISI - Thailand
- 35. RCM - Australia
- 36. ISI - India
- 37. Marking - Morocco
- 92. RoHS UAE
- 96. Electrotechnical expert ([download](#))
- 99. WEEE Directive ([download](#))

Technical data

Class group: Domestic switching devices

Class: Installation switch

Wiring system: Intermediate switch

Operating method: Rocker/button

Assembly arrangement: Modular device for domestic switching devices

Number of modules (module system): 1

Push button switch: Yes

Number of rockers: 1

Mounting method: Flush-mounted

Type of fastening: Engage (snap)

With mounting plate: No

Material: Plastic

Material quality: Thermoplastic

Halogen free: Yes

Surface protection: Untreated

Surface finishing: Matt

Colour: White

RAL-number (similar): 9016

Label space/information surface: Yes

Lighting: Optional

Function lighting: Control and orientation

Type of lighting: LED exchangeable

Suitable for degree of protection (IP): IP40

Nominal voltage: 250 V

Rated current: 16,00 A

Monitoring contact: No

Connection type: Screwed terminal

Washing machine switch: No

Device width: 22,30 mm

Device height: 49,00 mm

Device depth: 36,15 mm

Built-in depth: 25,00 mm

Packaging



8007352316546

Qtà 1 NR
Dim 4.1x2.8x5.3 [cm]
Weight 33.8 [g]



8007352316553

Qtà 50 NR
Dim 21.4x11.6x14.2 [cm]
Weight 1,778.07 [g]



8007352640696

Qtà 500 NR
Dim 57.5x22.5x30 [cm]
Weight 18,270 [g]

Legal

Vimar reserves the right to change at any time and without notice the characteristics of the products reported. Installation should be carried out by qualified staff in compliance with the current regulations regarding the installation of electrical equipment in the country where the products are installed. For the terms of use of the information on the product info sheet see [Conditions of Use](#).