



## EIKON: Switched 2P+E 15A English outlet white

**20217.L.B**

Wiring devices / Traditional wiring devices / EIKON / Devices

### Switched 2P+E 15A English outlet white

2P+E 15 A 250 V~ SICURY socket outlet, English standard, 2P 1-way switch, indicator unit, with built-in mounting frame for 3-module British standard installation, white

### Product Status

2 - Will be discontinued

### Minimum order quantity

10 NR



## Sheets, Manuals, Documentation

- [Multilanguage instructions sheet \(1337 kb\)](#)

## Drawings

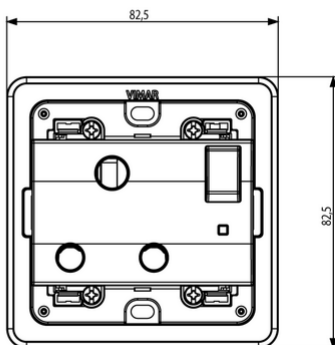
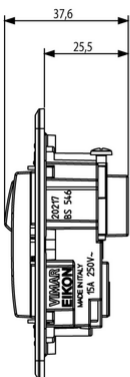

Space view

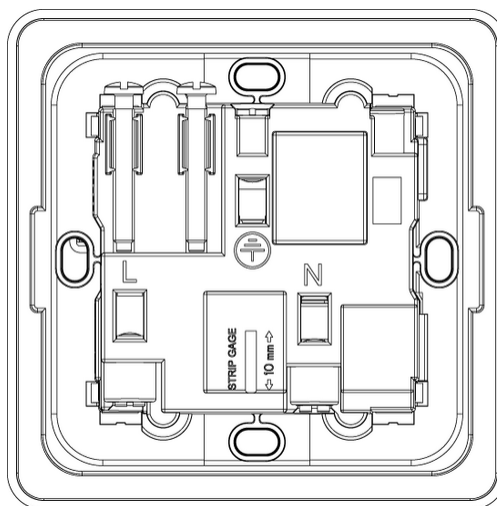

Backside view

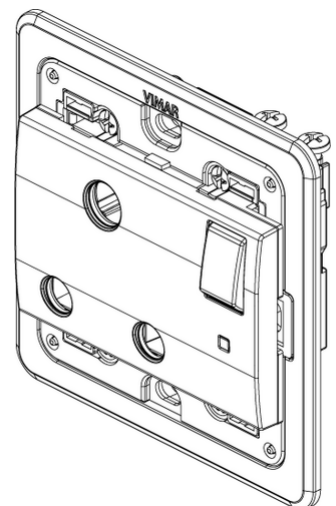

3D View

## Certifications

- 00. CE Marking - EU
- 08. ASTA - UK ([download](#))
- 37. Marking - Morocco
- 99. WEEE Directive ([download](#))

## Technical data

**Class group:** Domestic switching devices

**Class:** Socket outlet

**Model:** British Standard

**Number of socket outlets:** 2

**Number of modules (module system):** 2

**Number of socket outlets switchable:** 1

**Imprint/indication:** None

**Connection type:** Screwed terminal

**With hinged lid:** No

**With enhanced contact protection:** Yes

**Label space/information surface:** Yes

**Colour:** White

**RAL-number (similar):** 9016

**Metallic colour:** No

**Transparent:** No

**Lockable:** No

**Eject-mechanism:** No

**Insulated mounting:** No

**With function lighting:** Yes

**With orientation lighting:** No

**Overvoltage protection:** No

**Fault current protection:** No

**With miniature fuse:** No

**Mounting method:** Flush-mounted

**Type of fastening:** Mounting with screw

**Material:** Plastic

**Material quality:** Thermoplastic

**Halogen free:** Yes

**Surface protection:** Untreated

**Surface finishing:** Matt

**With loop through function:** No

**With on/off switch:** Yes

**Rotated central insert:** No

**Nominal current:** 15 A

**Nominal voltage:** 250 V

**Frequency:** 50,00 - 60,00 HZ

**Suitable for degree of protection (IP):** IP20

**Impact strength:** Other

**Device width:** 82,50 mm

**Device height:** 82,50 mm

**Device depth:** 37,60 mm

## Packaging



8007352399938

**Qtà** 1 NR

**Dim** 8.5x3.9x8.6 [cm]

**Weight** 104.4 [g]



8007352399945

**Qtà** 10 NR

**Dim** 20.7x18.5x9.6  
[cm]

**Weight** 1,141.4 [g]

## Legal

Vimar reserves the right to change at any time and without notice the characteristics of the products reported. Installation should be carried out by qualified staff in compliance with the current regulations regarding the installation of electrical equipment in the country where the products are installed. For the terms of use of the information on the product info sheet see [Conditions of Use](#).