



EIKON: RJ11 phone jack 6/4 Next

20320.N

Wiring devices / Traditional wiring devices / EIKON / Devices

RJ11 phone jack 6/4 Next

RJ11 phone jack, 6-position 4-conductor (6/4), screw terminals, Next

Product Status

3 - Active

Minimum order quantity

20 NR



Drawings

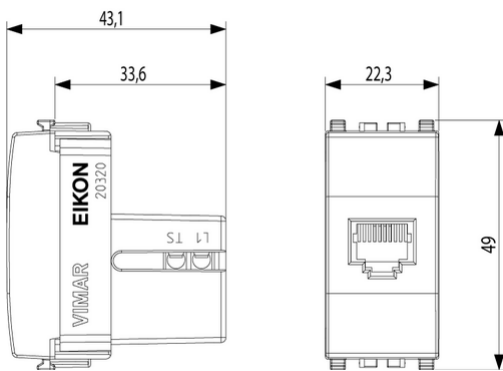

Space view

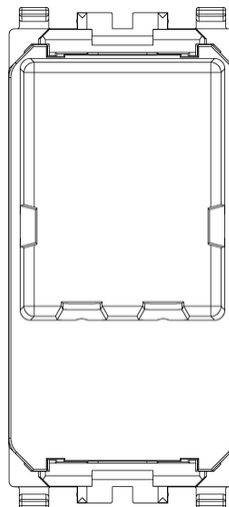

Backside view

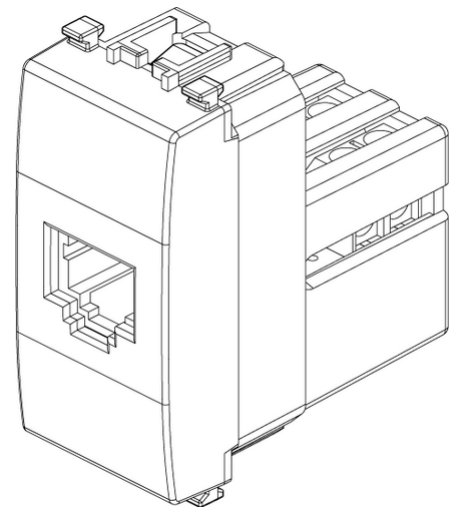

3D View

Certifications

• 00. CE Marking - EU

• 99. WEEE Directive ([download](#))

Technical data

Class group: Domestic switching devices

Class: Insert/cover for communication technology

Assembly arrangement: Modular device for domestic switching devices

Utilization: UAE/IAE (ISDN)

Support ring: No

With dust cover: No

With hinged lid: No

With imprint: No

Mounting method: Flush-mounted

Material: Plastic

Material quality: Thermoplastic

Halogen free: Yes

Surface protection: Lacquered

Surface finishing: Matt

Colour: Silver

RAL-number (similar): 9022

Transparent: No

Type of fastening: Clamp mounting

Number of modules (module system): 1

With strain relief: No

Luster terminal: No

Suitable for degree of protection (IP): IP20

Device width: 22,30 mm

Device height: 49,00 mm

Device depth: 43,10 mm

Packaging



8 007352 289970

8007352289970

Qtà 1 NR

Dim 5.1x2.8x5.3 [cm]

Weight 22.73 [g]



8 007352 289987

8007352289987

Qtà 20 NR

Dim 27x11.6x6 [cm]

Weight 525.47 [g]



8 007352 472853

8007352472853

Qtà 120 NR

Dim 37.5x30x13.5 [cm]

Weight 3,512.82 [g]



8 007352 750913

8007352750913

Qtà 5,760 NR

Dim 120x80x105 [cm]

Weight 168,595 [g]

Legal

Vimar reserves the right to change at any time and without notice the characteristics of the products reported. Installation should be carried out by qualified staff in compliance with the current regulations regarding the installation of electrical equipment in the country where the products are installed. For the terms of use of the information on the product info sheet see [Conditions of Use](#).