



EIKON: Red prismatic indicator unit

20387.R

Wiring devices / Traditional wiring devices / EIKON / Devices

Red prismatic indicator unit

Prismatic indicator unit for lamps 230 V~ 3 W max, 14770, 14771, 14776 and 14777, red diffuser - 2 modules. Lamp not provided

Product Status

3 - Active

Minimum order quantity

5 NR

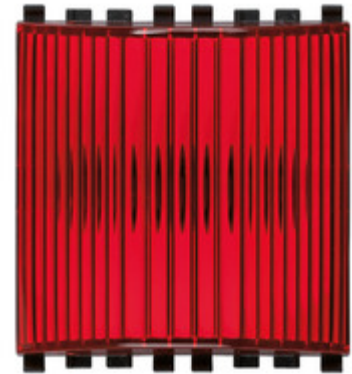

Drawings

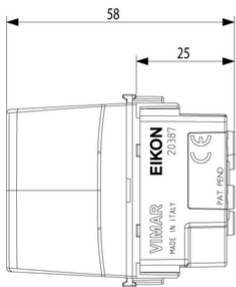

Space view

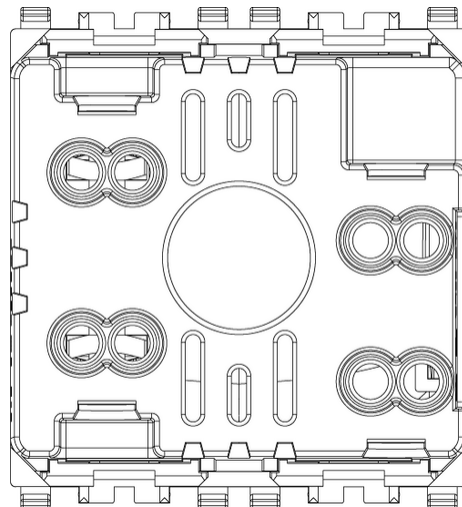
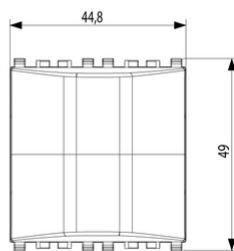

Backside view

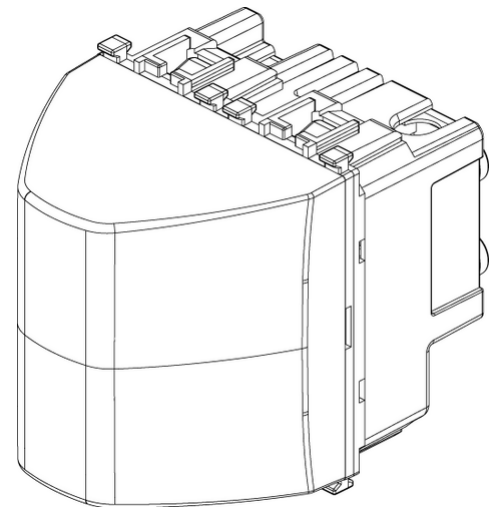

3D View

Certifications

- 00. CE Marking - EU
- 96. Electrotechnical expert ([download](#))
- 99. WEEE Directive ([download](#))

Technical data

Class group: Domestic switching devices

Class: Information light signal for domestic switching devices

Assembly arrangement: Modular device for domestic switching devices

Number of modules (module system): 2

Lamp holder: E10

With light source: No

Lamp type: Incandescent lamp

With flashlight: No

With fixed symbol/imprint: No

With exchangeable symbol: No

Mounting method: Flush-mounted

Type of fastening: Engage (snap)

Material: Plastic

Material quality: Thermoplastic

Halogen free: Yes

Surface protection: Untreated

Surface finishing: Matt

Colour: Grey

RAL-number (similar): 3001

Transparent: No

Colour light source: Red

Suitable for degree of protection (IP): IP40

Nominal voltage: 230 V

Max. lamp power: 3 W

Device width: 44,80 mm

Device height: 49,00 mm

Device depth: 58,00 mm

Packaging



8 007352 265288

8007352265288

Qtà 1 NR

Dim 6x5.4x5.3 [cm]

Weight 43.2 [g]



8 007352 265295

8007352265295

Qtà 5 NR

Dim 17.2x13.1x6 [cm]

Weight 279.27 [g]

Legal

Vimar reserves the right to change at any time and without notice the characteristics of the products reported. Installation should be carried out by qualified staff in compliance with the current regulations regarding the installation of electrical equipment in the country where the products are installed. For the terms of use of the information on the product info sheet see [Conditions of Use](#).