



EIKON: 1P+N C16 RCBO 120-230V 6mA Next

20411.16.6.N

Wiring devices / Traditional wiring devices / EIKON / Devices

1P+N C16 RCBO 120-230V 6mA Next

1P+N C 16 residual current breaker with overcurrent protection, supply voltage 120-230 V~ 50-60 Hz, $I_{\Delta n}$ 6 mA, breaking capacity 3000 A, Next - 2 modules

Product Status

3 - Active

Minimum order quantity

5 NR

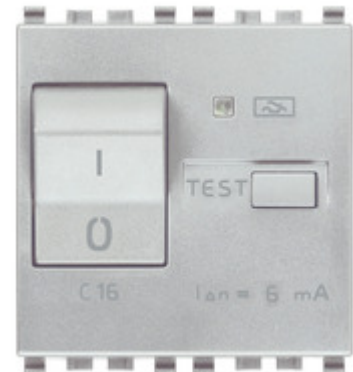

Sheets, Manuals, Documentation

- [Multilanguage instructions sheet \(688 kb\)](#)

Drawings

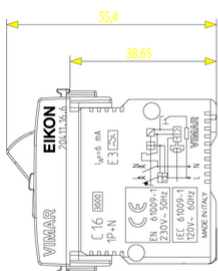

Space view

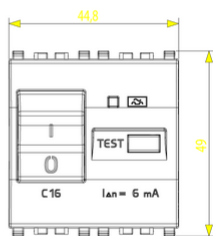

Backside view

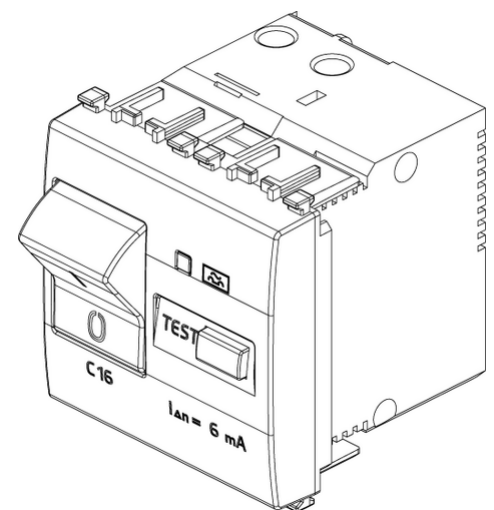
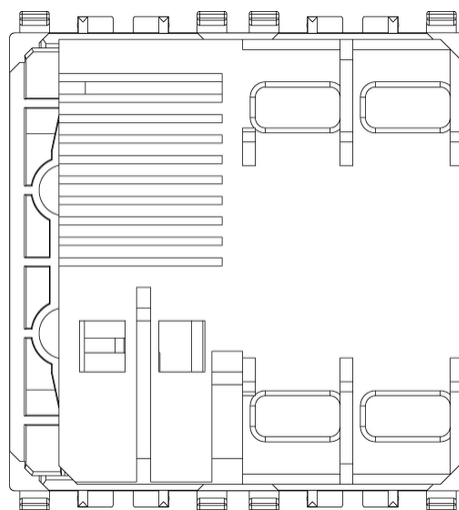

3D View

Certifications

- 00. CE Marking - EU
- 01. IMQ - Italy ([download](#))
- 37. Marking - Morocco
- 96. Electrotechnical expert ([download](#))
- 99. WEEE Directive ([download](#))

Technical data

Class group: Circuit breakers and fuses

Class: Earth leakage circuit breaker

Number of poles (total): 2

Number of protected poles: 1

Rated voltage: 230 V

Rated current: 16 A

Rated fault current: 16 A

Mounting method: Built-in

Leakage current type: A

Current limiting class: 1

Rated short-circuit breaking capacity I_{cn} according to EN 61009-1: 3.000,00 kA

Surge current capacity: 3,00 kA

Voltage type: AC

Frequency: 50/60 Hz

Release characteristic: C

Concurrently switching neutral conductor: Yes

Overvoltage category: 3

Built-in depth: 38,00 mm

Anti-nuisance tripping version: No

Degree of protection (IP): IP40

Packaging



8 007352 286504

8007352286504

Qtà 1 NR

Dim 6x5.4x5.3 [cm]

Weight 94.73 [g]



8 007352 286511

8007352286511

Qtà 5 NR

Dim 17.2x13.1x6 [cm]

Weight 532.27 [g]



8 007352 664159

8007352664159

Qtà 70 NR

Dim 37.5x30x21 [cm]

Weight 7,860 [g]

Legal

Vimar reserves the right to change at any time and without notice the characteristics of the products reported. Installation should be carried out by qualified staff in compliance with the current regulations regarding the installation of electrical equipment in the country where the products are installed. For the terms of use of the information on the product info sheet see [Condizioni di utilizzo](#).