



## EIKON: Plate 2M aluminium lava grey

**21642.03**

Wiring devices / Traditional wiring devices / EIKON / Cover plates

### Plate 2M aluminium lava grey

2-module cover plate, Primari anodized aluminium, lava grey

### Product Status

3 - Active

### Minimum order quantity

1 NR



## Drawings

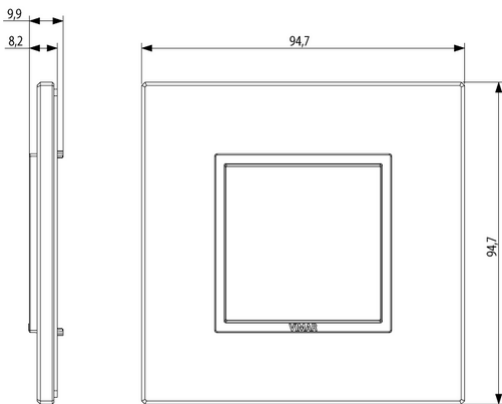

Space view

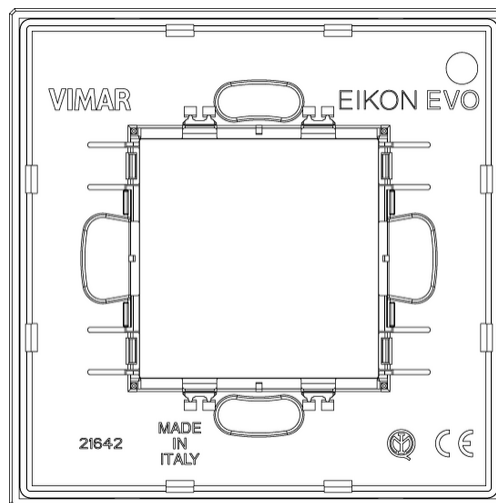

Backside view

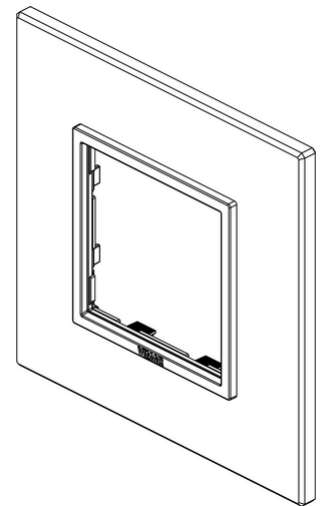

3D View

## Certifications

- 00. CE Marking - EU
- 01. IMQ - Italy ([download](#))
- 00. CE Marking - EU
- 08. ASTA - UK ([download](#))

## Technical data

**Class group:** Domestic switching devices

**Class:** Cover frame for domestic switching devices

**Number of units:** 2

**Mounting direction:** Horizontal and vertical

**Number of device inserts horizontal:** 2

**Number of device inserts vertical:** 1

**Number of modules horizontal (module system):** 2

**Number of modules vertical (module system):** 1

**With mounting grid:** Yes

**Suitable for subfloor installation duct box:** Yes

**Suitable for wall duct:** Yes

**Suitable for built-in installation:** Yes

**Label space/information surface:** Yes

**Material:** Metal

**Material quality:** Aluminium

**Halogen free:** Yes

**Surface protection:** Anodised

**Surface finishing:** Matt

**Colour:** Grey

**RAL-number (similar):** 7043

**Transparent:** No

**With hinged lid:** No

**Degree of protection (IP):** IP00

**Type of fastening:** Clamp mounting

**Width:** 94,70 mm

**Height:** 94,70 mm

**Depth:** 8,200 mm

**Built-in width:** 94,70 mm

**Built-in height:** 94,70 mm

**Diameter bore hole (opening):** 0,00 mm

## Packaging



8 007352 418479

8007352418479

**Qtà** 1 NR

**Dim** 10.85x11.6x1.85  
[cm]

**Weight** 73.8 [g]



8 007352 434165

8007352434165

**Qtà** 5 NR

**Dim** 11.65x10.8x12.6  
[cm]

**Weight** 420 [g]

## You may also be interested in



21602 - Frame 2M  
+claws 71mm



21603 - Frame 2M  
without screws 71mm

## Legal

Vimar reserves the right to change at any time and without notice the characteristics of the products reported. Installation should be carried out by qualified staff in compliance with the current regulations regarding the installation of electrical equipment in the country where the products are installed. For the terms of use of the information on the product info sheet see [Conditions of Use](#).