



EIKON: Plate 4M stone natural split slate

21654.52

Wiring devices / Traditional wiring devices / EIKON / Cover plates

Plate 4M stone natural split slate

4-module cover plate, carved stone, natural split slate

Product Status

3 - Active

Minimum order quantity

1 NR



Drawings

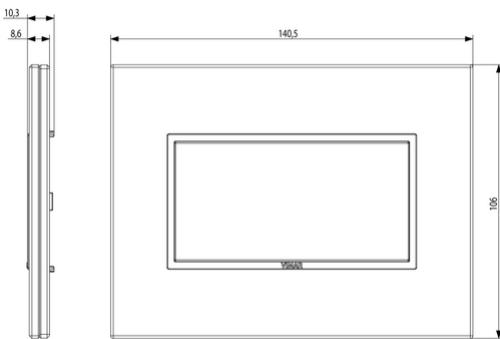

Space view

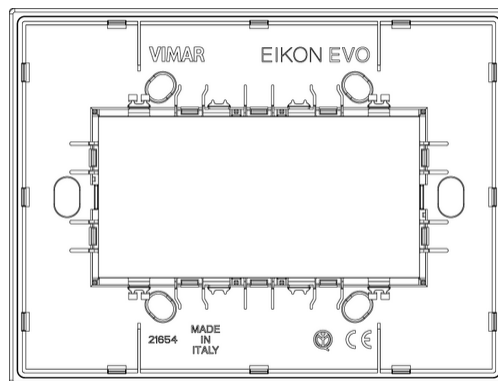

Backside view

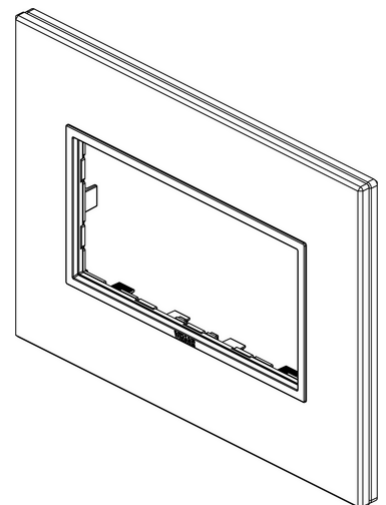

3D View

Certifications

- 00. CE Marking - EU
- 01. IMQ - Italy ([download](#))
- 00. CE Marking - EU

Technical data

Class group: Domestic switching devices

Class: Cover frame for domestic switching devices

Number of units: 4

Mounting direction: Horizontal and vertical

Number of device inserts horizontal: 4

Number of device inserts vertical: 1

Number of modules horizontal (module system): 4

Number of modules vertical (module system):
1

With mounting grid: Yes

Suitable for subfloor installation duct box: Yes

Suitable for wall duct: Yes

Suitable for built-in installation: Yes

Label space/information surface: Yes

Material: Stone

Material quality: Slate

Halogen free: Yes

Surface protection: Untreated

Surface finishing: Matt

Colour: Slate

RAL-number (similar): 7011

Transparent: No

With hinged lid: No

Degree of protection (IP): IP00

Type of fastening: Clamp mounting

Width: 140,50 mm

Height: 106,00 mm

Depth: 10,300 mm

Built-in width: 140,50 mm

Built-in height: 106,00 mm

Diameter bore hole (opening): 0,00 mm

Packaging



8007352419063

Qtà 1 NR

Dim 18x14.1x3.9 [cm]

Weight 212.4 [g]

You may also be interested in



21614 - Frame 4M
+screws

Legal

Vimar reserves the right to change at any time and without notice the characteristics of the products reported. Installation should be carried out by qualified staff in compliance with the current regulations regarding the installation of electrical equipment in the country where the products are installed. For the terms of use of the information on the product info sheet see [Conditions of Use](#).