



LINEA: 1P NO 10A button black

30008.G

Wiring devices / Traditional wiring devices / LINEA / Devices

1P NO 10A button black

1P NO 10 A 250 V~ lightable aligned push button, replaceable button, black

Product Status

3 - Active

Minimum order quantity

50 NR



Drawings

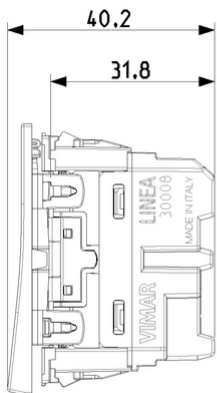

Space view

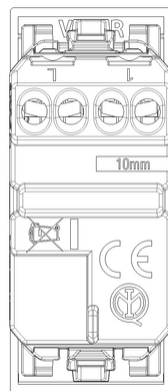

Backside view

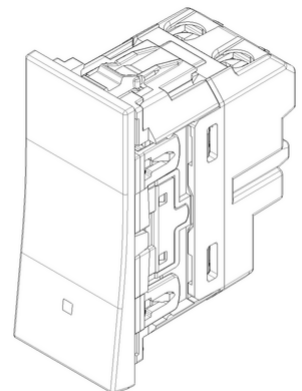

3D View

Certifications

- 00. CE Marking - EU
- 01. IMQ - Italy ([download](#))
- 11. SNI-SUCOFINDO Indonesia
- 13. SNI-MGI - Indonesia
- 37. Marking - Morocco
- 50. Product Environm. Profile
- 96. Electrotechnical expert ([download](#))
- 99. WEEE Directive ([download](#))

Technical data

Class group: Domestic switching devices

Class: Push button

Assembly arrangement: Modular device for domestic switching devices

Model: Other

Operating method: Push button

Number of contacts as normally closed contact: 0

Number of contacts as normally open contact: 1

Number of contacts as change-over contact: 0

Number of revolving contacts: 0

Contactless type: No

Number of rockers: 1

Number of modules (module system): 100

Number of poles: 1

Nominal voltage: 250 V

Rated current: 10,00 A

With lighting: No

With light source: No

With signal lamp: No

Monitoring contact: No

Connection type: Screwed terminal

Mounting method: Built-in

Type of fastening: Engage (snap)

Material: Plastic

Material quality: Thermoplastic

Halogen free: Yes

Anti-bacterial treatment: No

Surface protection: Untreated

Surface finishing: Matt

Colour: Black

RAL-number (similar): 7021

Transparent: No

Label space/information surface: No

Imprint: None

Suitable for degree of protection (IP): IP40

Device width: 22,30 mm

Device height: 52,70 mm

Device depth: 40,20 mm

Compatible with Apple HomeKit: No

Compatible with Google Assistant: No

Compatible with Amazon Alexa: No

IFTTT support available: No

Packaging



8 007352 683013

8007352683013

Qtà 1 NR
Dim 4.6x2.7x5.6 [cm]
Weight 29.98 [g]



8 007352 683020

8007352683020

Qtà 50 NR
Dim 25.7x14.8x12.8 [cm]
Weight 1,638 [g]



8 007352 683037

8007352683037

Qtà 300 NR
Dim 45.5x27x27 [cm]
Weight 10,260 [g]



8 007352 749900

8007352749900

Qtà 5,400 NR
Dim 120x80x105 [cm]
Weight 185,000 [g]

You may also be interested in



00943.W - Linea 110-250V white LED unit



30000.G - 1P 10AX 1-way switch in-line black



30004.G - 1P 10AX 2-way switch black



30012.G - 1P 10AX reversing switch in-line black

Legal

Vimar reserves the right to change at any time and without notice the characteristics of the products reported. Installation should be carried out by qualified staff in compliance with the current regulations regarding the installation of electrical equipment in the country where the products are installed. For the terms of use of the information on the product info sheet see [Conditions of Use](#).