



LINEA: Relay actuator 16A sensor canvas

30474.C

Smart systems&products / By-me Plus / LINEA / Devices

Relay actuator 16A sensor canvas

Actuator with relay output 16 A 230 V ~ 50 Hz with integrated current sensor, canvas - 2 modules

Product Status

3 - Active

Minimum order quantity

1 NR

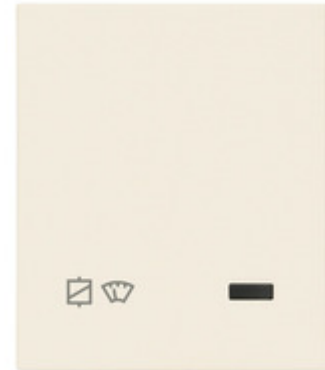

Sheets, Manuals, Documentation

- [Light multilanguage instructions sheet \(1035 kb\)](#)
- [Full Multilanguage instructions sheet \(994 kb\)](#)

Drawings

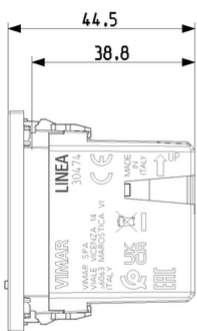

Space view

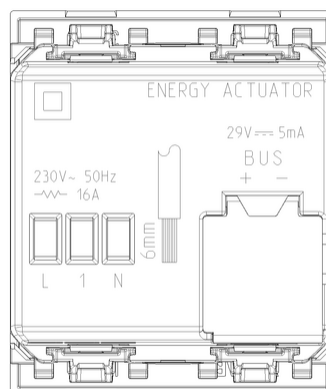
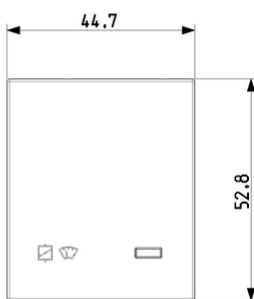

Backside view

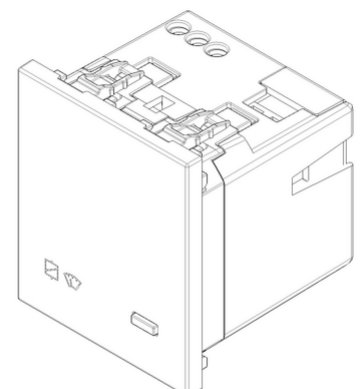

3D View

Certifications

- 00. CE Marking - EU
- 37. Marking - Morocco
- 46. UK PSTI compliance ([download](#))
- 99. WEEE Directive ([download](#))

Technical data

Class group: Installation bus systems

Class: Switch actuator for bus system

Bus system KNX: No

Bus system KNX-RF (Radio Frequency): No

Bus system radio frequency: No

Bus system LON: No

Bus system Powernet: No

Other bus systems: None

Radio frequency bidirectional: No

Mounting method: Flush-mounted

Width in number of modular spacings: 2

Local operation/hand operation: No

With LED indication: Yes

Number of digital inputs: 0

Suitable for C-load: Yes

Max. number of switching contacts: 1

Max. switching current: 16 A

Rated current: 16 A

Rated operating voltage: 230,00 - 230,01 V

Different phases connectable: No

With bus connection: Yes

Bus module detachable: No

Modular expandability: No

Degree of protection (IP): IP40

Packaging



8 007352 689725

8007352689725

Qtà 1 NR

Dim 6x5.4x5.2 [cm]

Weight 61.8 [g]



8 007352 689732

8007352689732

Qtà 10 NR

Dim 28.1x13.1x6 [cm]

Weight 618 [g]

Legal

Vimar reserves the right to change at any time and without notice the characteristics of the products reported. Installation should be carried out by qualified staff in compliance with the current regulations regarding the installation of electrical equipment in the country where the products are installed. For the terms of use of the information on the product info sheet see [Conditions of Use](#).