



**By-alarm**

**01700.120**

24 zone 120 V~ 60 Hz control panel

**Installation Manual**



## Table of Contents

<b>1. By-alarm burglar alarm system</b>	<b>5</b>
1.1 System layout	5
1.2 System logic	6
<b>2. Control unit 01700.120</b>	<b>7</b>
2.1 Technical characteristics	7
2.2 Control unit board	8
<b>3. Preconfiguring the control unit</b>	<b>9</b>
3.1 Default settings	9
3.2 Connections to make	9
3.3 Operation	10
<b>4. Installation</b>	<b>11</b>
4.1 Assembly	11
4.2 Device preventing removal of control unit	11
4.3 Periodic maintenance	11
4.4 Regulatory compliance	11
4.5 Certification coverage EN 50131	11
<b>5. Power supply unit</b>	<b>12</b>
5.1 Cable entry	12
5.2 Fuses	12
5.3 Control unit earth connection	12
5.4 Batteries	12
5.5 Operating current	13
5.6 Criteria for sizing the system	14
<b>6. Connecting the devices</b>	<b>16</b>
6.1 RS 485 serial link	16
6.2 Connecting 4-wire devices	17
6.3 Connecting 5-wire devices	17
<b>7. Inputs</b>	<b>18</b>
7.1 Control unit	18
7.2 Input expansion modules and radio frequency interface	20
7.3 Addressing the input expansion modules and radio frequency interfaces	20
<b>8. Outputs</b>	<b>21</b>
8.1 Relay 1 output	21
8.2 Relay 2 output	22
8.3 CN10 connector	22
<b>9. PSTN communicator 01708</b>	<b>23</b>
9.1 PSTN communicator 01708	23
9.2 Inserting the board in the control unit	23
<b>10. Voice synthesis module 01713.EN</b>	<b>23</b>
10.1 Voice synthesis module 01713.EN	23
10.2 Inserting the module in the control unit	23
10.3 Recording synthesis messages	24
<b>11. GSM transmitter/receiver module 01706</b>	<b>25</b>
11.1 GSM module 01706	25
11.2 Inserting the module in the control unit	25
11.3 Inserting the GSM module in the control unit	25
11.4 Connecting the aerial	26
11.5 Installing the SIM	26
<b>12. Connector 20478-19478-14478</b>	<b>27</b>
12.1 General information	27
12.2 Operation	27
12.3 Connections	27
12.4 Addressing the connectors	28

## Table of Contents

---

<b>13. Control unit hardware reset</b> .....	<b>29</b>
13.1 Reset button .....	29
13.2 DIP-switch SW1 .....	29
13.3 Resetting the Codes .....	29
13.4 General reset .....	29
<b>14. Setting the English language</b> .....	<b>30</b>
<b>15. Interfacing with the By-me system</b> .....	<b>31</b>
15.1 Connection diagram .....	31
15.2 Integrating with the By-me system .....	31
15.3 Local and remote maintenance via the By-alarm Manager software .....	31
<b>ANNEX</b> .....	<b>32</b>
I. Wiring .....	33

### 1. By-alarm burglar alarm system

#### 1.1 System layout

The By-alarm system consists of a 24-zone control unit (art. 01700.120) to which are directly connected the wired detectors and the outdoor and indoor sirens; the connectors, keypads and any wired or radio expansion modules are instead connected via the specific RS485 bus.

The RS485 bus of the By-alarm system is built to the RS485 electrical standard and is NOT compatible with the By-me bus. The burglar alarm system can in any case be interfaced with the By-me system (for full details, please refer to chapter 15).

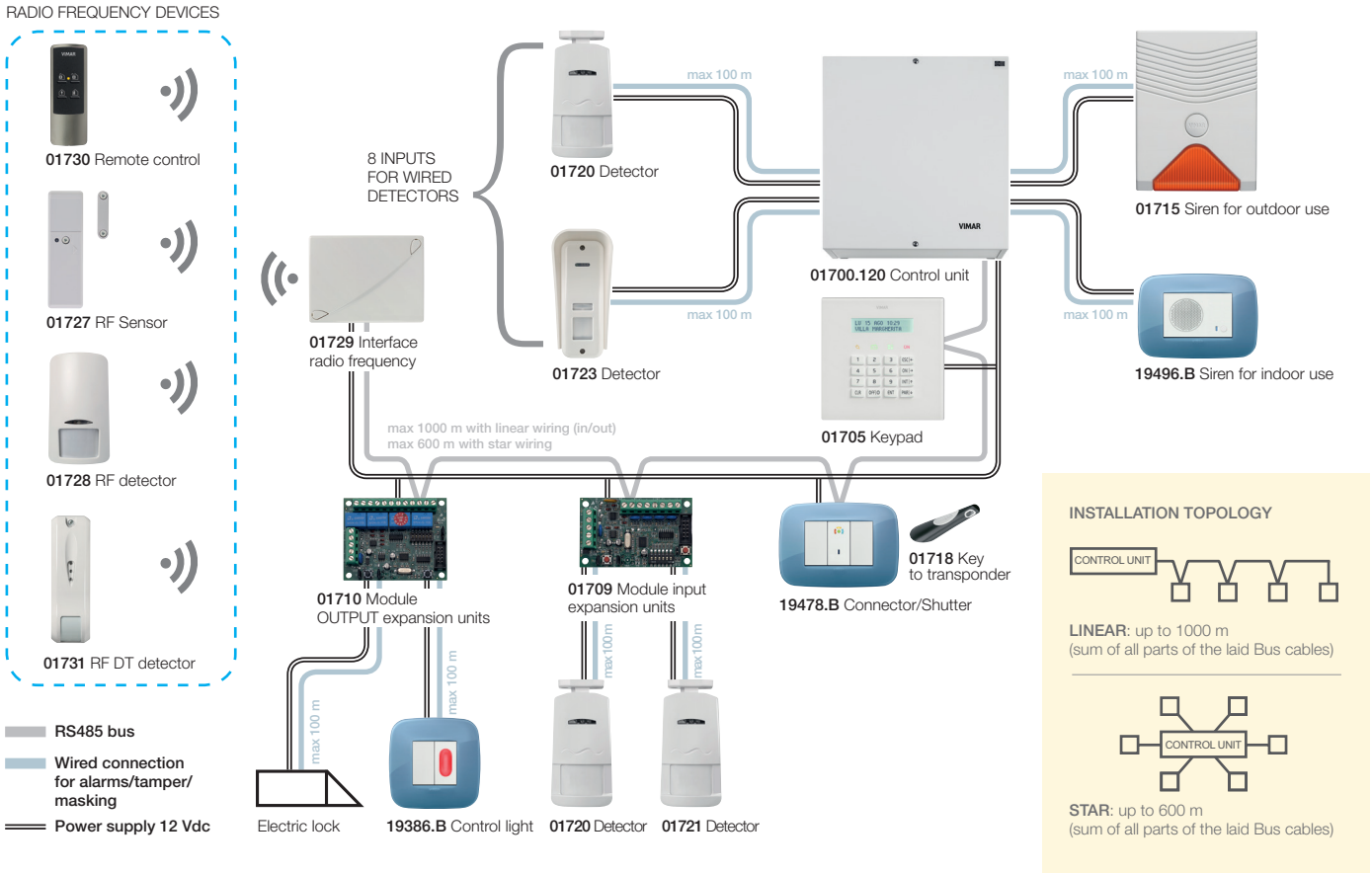

The system is star wired to the control unit that, for the wired inputs, acts as a star centre.

The control unit is equipped with:

- wired inputs (zones 1-8) that let you connect the wired detectors directly to the inputs.
- an RS485 bus to which the following can be connected:
  - LED backlit keypad with display (art. 01705)
  - 4-input expansion module (art. 01709)
  - 4-output expansion module (art. 01710)
  - 8-input expansion module (art. 01704)
- CAUTION: The 8-input expansion module 01704 is compatible with the control unit 01700 having firmware version 1.2 or later; before installing the device, use the keyboard 01705 to check the firmware version of the control unit in the system. Alternatively, check that the tracking code shown on the label of the control unit on which you are installing the device is equal to or greater than XXXXXXXXXXX1.02.
- Isolated interface (art. 01711)
- Flush-mounting connector (art. 20478-19478-14478)
- Radio frequency interface (art. 01729)
- connection interfaces to install the following additional modules:
  - GSM transmitter/receiver module (art. 01706)
  - PSTN communicator (art. 01708)
  - Voice synthesis module (art. 01713.EN)
  - Interface to Ethernet network (art. 01712)
- connector for programming via PC with By-alarm Manager software through the interfaces and cables (art. 01725)

The control unit is equipped with two relays:

- Relay 1 (dual changeover, of which one potential free and one connected to the 12 V of the power supply) is typically used to command the self-powered outdoor siren (terminals +S, EXT) and, when fitted, the indoor siren (terminals +S, INT).
- Relay 2 (single changeover, potential free) can be freely programmed depending on the needs of each individual case. Typically it can be associated with the system on/off status (SET terminal).

## By-alarm burglar alarm system

The inputs are expandable up to 24 using the input expansion modules (art. 01709 and 01704) or via the radio frequency interface (art. 01729) to be connected to the RS485 bus of the control unit.

The freely programmable outputs are expandable up to 24 using the output expansion module (art. 01710) to be connected to the RS485 bus of the control unit.

When configuring, each bus device must be assigned an ID address; these addresses must be assigned sequentially for each device category, ie:

- Keypads 01705 -> ID= from 1 to n
- Connectors 20478-19478-14478 -> ID= from 1 to n
- 4-input expansion modules 01709, 8-input expansion modules 01704 and radio frequency interfaces 01729 -> ID = from 1 to n  
The 4-input expansion modules, 8-input expansion modules 01704 and the radio frequency interface belong to the products for input expansion and so the addresses assigned to the devices of this type connected on the RS485 bus must be sequential and correlated (for full details see par. 7.3).
- 4-output expansion modules 01710 -> ID = from 1 to n

**During configuration, you must assign ID=1 to the first device in each category and then continuing sequentially.**

*Example of addressing a system with control unit 01700.120:*

- 2 keypads 01705 -> ID keypad 1=1, ID keypad 2=2.
- 3 connectors 20478-19478-14478 -> ID connector 1=1, ID connector 2=2, ID connector 3=3.
- 1 4-input expansion module 01709 -> ID=1.
- 1 radio interface 01729 configured with 8 inputs -> ID=2.
- 1 4-output expansion module 01710 -> ID=1.

Addressing is also performed with the By-alarm Manager software via the **Devices** menu by selecting the appropriate device category.

### 1.2 System logic

#### Area:

The Area is a set of zones (detectors) of the system.

The control unit can manage up to 8 different areas.

**Within each area, 3 connection modes (partitioning) are then defined: ON, INT and PAR.**

**The zones belonging to the area are thus assigned to one or more connection modes.**

**The system allows a given area to be connected in one (and only one) of the ON, INT or PAR modes; once an area is connected using one of these modes, it can only be disconnected.**

#### Example:

Suppose you have a system consisting of a few zones of outdoor detectors (e.g. volumetric detectors for the garden), some zones with perimeter detectors (such as contacts for windows/roller shutters) and finally a day zone and a night zone with indoor volumetric detectors (e.g. dual technology detectors (art. 20479-19479-14479)).

You define a single area (in this case it can be considered as the system itself) with the three connection modes:

- **ON** = all zones (total connection)
- **INT** = zones with outdoor detectors and perimeter detectors
- **PAR** = zones with outdoor detectors, perimeter and volumetric detectors for the day zone.

When leaving home you put the area into ON mode (total connection).

When you are at home and you want to protect the outdoor setting you put the area into INT mode (outdoor and perimeter detectors).

When it's bedtime you put the area into PAR mode so as to be able to move about freely in the night zone while the external, perimeter and volumetric detectors of the day zone are all active.

In each case, when the area is connected using any mode, it can only be totally disconnected.

The control unit lines can also be programmed as external arming inputs, both total and partial. The control unit accepts "pulse" commands, that affect the control unit both as regards external arming performed by unbalancing the lines programmed as arming inputs and for those performed by the weekly scheduler integrated in the control unit.

#### Pulse command.

Momentary unbalancing of a programmed line in one of the arming modes will cause the control unit to switch on; a subsequent momentary unbalancing will bring it back into the OFF state. With this type of command you can control switching on from various points (for example: switch on with the keypad and off with an external command or the scheduler) independently.

In this way any external switch-on command can be used, such as card readers or radio transmitters that will need to have the same level of performance as the control unit and need to be installed with the decoding board inside the control unit enclosure.

By appropriately programming the active outputs, you can control external circuit test signals indicating the bypassed zone and system armed signals indicating an alarm.

#### User management:

Each user is recognised by the system through a 4 to 6 digit PIN set during the system installation phase.

You can accurately define the operations that can be carried out by each user (for example ON/INT/PAR connection, disconnection) and the areas in which actions can be performed. **A zone can belong to more than one area.**

The possibility to create several areas, by defining the connection mode (flexible with respect to the zones), and the timely management of user rights make for an extremely flexible system.

Several areas can in fact be used to:

- Manage parts of the system separately using one single control unit; you can configure 2 areas with different zones and define the users who can control any given area.
- Increase the connection modes: more than one area can be defined with the same zones (or zone subsets) and with different connection modes; this increases the total connection modes that are available and that can therefore be linked to the various users.

### 2. Control unit 01700.120

Microprocessor control unit with 8 input lines, expandable to 24 zones, management with the keypad 01705 and with connector 20478-19478-14478, designed for connecting to **PSTN communicator** 01708 and installing the **voice synthesis module** 01713.EN and the **GSM transmitter/receiver module** mod. 01706. The backlit display allows the user to communicate easily and directly with regard to all system management functions.

The **PSTN communicator** 01708 can manage digital communications of all events, both alarm and technical events, to computers and control centres; the **voice synthesis module** 01713.EN lets you send all communications, both alarm and technical ones, by voice, combining pre-recorded messages.

The **programming** can be done in the following ways:

- via pc equipped with By-alarm Manager software that connects directly to the control unit using the interfaces and cables 01725;
- using the facilitated menus of the keypad 01705;
- with two-way connection over the phone line (this requires the By-me Web Server being installed in the system).

**CAUTION: The control unit is supplied already preconfigured for an initial coverage of 6 zones as illustrated in Chapter 3.**

#### 2.1 Technical characteristics

<b>Input lines</b>	<ul style="list-style-type: none"> <li>• 8, expandable to 24, with single, double or triple balance (with detector masking recognition)</li> <li>• 1 tamper-proof protection line</li> </ul>
<b>Areas</b>	<ul style="list-style-type: none"> <li>• inputs that can be linked to 8 AREAS</li> </ul>
<b>Keypads</b>	<ul style="list-style-type: none"> <li>• up to 4 can be connected over bus RS485</li> <li>• direct signalling via LED of the power supply status, system status and circuit test</li> </ul>
<b>Connectors:</b>	<ul style="list-style-type: none"> <li>• No. 4 connectors 20478-19478-14478 that can be connected over bus RS485</li> </ul>
<b>Outputs</b>	<ul style="list-style-type: none"> <li>• No. 2 separately programmable alarm relays, one of which with 2 positive safety exchanges</li> </ul>
<b>Input modules</b>	<ul style="list-style-type: none"> <li>• input expansion module 01709 with 4 input lines of single, double or triple balance (with detector masking recognition). The maximum number of modules 01709 that can be installed is 4 (valid data if there are no 8-input expansion modules 01704 and radio frequency interface 01729).</li> <li>• input expansion module 01704 with 8 input lines of single, double or triple balance (with detector masking recognition). The maximum number of modules 01704 that can be installed is 2 (valid data if there are no 4-input expansion modules 01709 and radio frequency interface 01729).</li> <li>• radio frequency interface 01729 with 8 or 16 radio zones of single or double balance with management of detector supervision, programmable using the same modes as the standard zones. The maximum number of interfaces 01729 that can be installed is 1 in the case of 16-channel configuration and 2 in the case of 8-channel configuration (valid data if there are no input expansion modules 01709 and 01704).</li> </ul>
<b>Output modules</b>	<ul style="list-style-type: none"> <li>• output expansion module 01710 with 4 outputs with programmable voltage free exchange relay (3 A 24 V). The maximum number of modules 01710 that can be installed is 6.</li> </ul>
<b>Macro</b>	<ul style="list-style-type: none"> <li>• No. 20 macro-instructions with 10 commands each, which can be activated via: <ul style="list-style-type: none"> <li>- zone displacement and alarm, system event</li> <li>- programmable time switch</li> <li>- user RFA function</li> </ul> </li> </ul>
<b>Codes</b>	<ul style="list-style-type: none"> <li>• 50 User Codes with programmable function limitation</li> <li>• 50 Emergency Codes</li> <li>• 1 Installation Code</li> </ul>
<b>Activation</b>	<ul style="list-style-type: none"> <li>• 3 activation modes for each Area (ON, INT, and PAR)</li> <li>• the possibility of external activations with proximity reader in 3 modes for each Area</li> <li>• by User Telemanagement, guided by voice menu or SMS via the By-phone and By-web apps</li> <li>• via hourly/weekly programmable time switch in the 3 modes for each Area</li> </ul>
<b>Clock</b>	<ul style="list-style-type: none"> <li>• weekly clock with 32 daily operations and exclusion management</li> <li>• possibility of switching on and off, code and keypad restriction, macro activation</li> <li>• time and status activation of active outputs</li> </ul>
<b>Telephone</b>	<ul style="list-style-type: none"> <li>• 16 phone numbers for communication with protocols: <ul style="list-style-type: none"> <li>- <b>SIA</b> for communications with standard SIA receivers</li> <li>- <b>SIA</b> for communications with standard CONTACT receivers</li> </ul> </li> <li>• voice synthesis module <b>01713.EN</b> with voice protocol for automatic communication, allowing for all alarm and control unit functions to be sent to private Users</li> <li>• transmitter/receiver module <b>01706</b> for automatic communications that enables sending all the protocols over a GSM network and, via SMS text messages, all the alarm and control functions of the control unit</li> </ul>
<b>Programming</b>	<ul style="list-style-type: none"> <li>• using the keypad with simplified menus and error management</li> <li>• via computer with <b>interactive connection</b> via the By-alarm Manager software for Windows operating systems.</li> </ul>
<b>Power supply unit</b>	<ul style="list-style-type: none"> <li>• 13.8 Vdc 1.5 A actual total with low battery charge and mains voltage failure signalling</li> </ul>
<b>Battery that can be housed</b>	<ul style="list-style-type: none"> <li>• 12 Vdc 7 Ah or 12 Vdc 18Ah flammability class UL94-HB</li> </ul>
<b>Environmental cond.</b>	<ul style="list-style-type: none"> <li>• -10..+40°C</li> </ul>
<b>Enclosure</b>	<ul style="list-style-type: none"> <li>• Dimensions: 322 x 350 x 115 mm. - Weight: 3.5 kg.</li> </ul>
<b>Degree of safety</b>	<ul style="list-style-type: none"> <li>• 2 (EN 50131-3, EN 50131-6)</li> </ul>
<b>Ambient class</b>	<ul style="list-style-type: none"> <li>• II (EN 50131-3, EN 50131-6)</li> </ul>

### 2.2 Control unit board

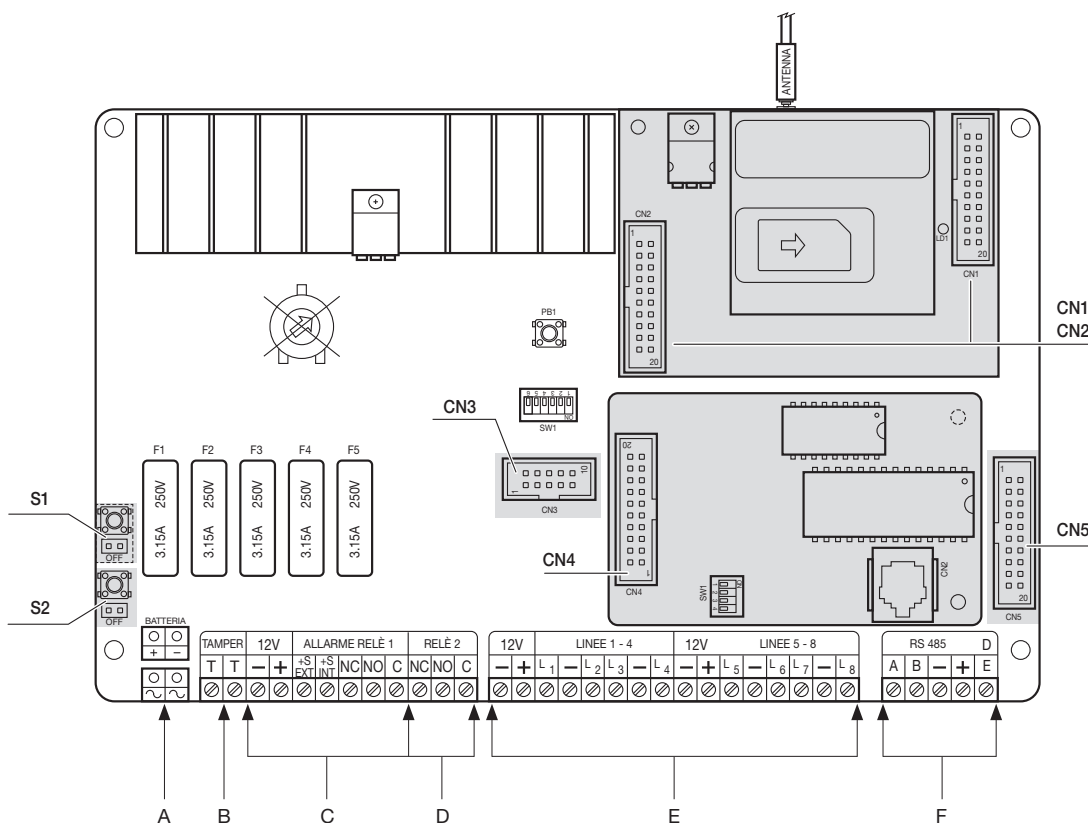

A: Self-powering battery terminals.

B: Tamper-proof line.

C: Output RELAY 1. Positive safety relays, with double exchange, with 1A capacity each. A voltage free exchange is provided at the output where C is the common, NC is the normally closed exchange and NO is the normally open one; the other one is provided already polarized for connecting the self-powered sirens and the optional non-self-powered internal sirens.

-/+ : power supply for recharging the batteries of the self-powered sirens; the positive is protected by the 3.15A 250V fuse F3.

+S ext: command positive for the self-powered sirens; it constantly provides a positive which fails in the event of an alarm and is protected by the 3.15A 250V fuse F4.

+S int: power supply positive for the optional non-self-powered sirens; it provides a positive in the event of an alarm and is protected by the 3.15A 250V fuse F4.

D: Output RELAY 2. Non-positive safety relay, with exchange with 1A capacity. The voltage-free exchange is provided at the output where C is the common, NC is the normally closed exchange and NO is the normally open one.

E: Input lines configurable individually or with double or triple balancing; there are also the 12 Vdc power supply outputs for any detectors.

F: RS485 bus line.

- CN1 CN2: Connectors for GSM transmitter/receiver module 01706
- CN3: Connector for configuration interface 01725 or for Ethernet (LAN) network interface for remote supervision/control over IP 01712 combined with the web server 01945-01946.
- CN4: Connector for voice synthesis module 01713.EN
- CN5: Connector for PSTN communicator 01708
- S1: Tear-proof bypassing
- S2: Opening bypassing



## Preconfiguring the control unit

### 3. Preconfiguring the control unit

The control unit 01700.120 is supplied already pre-configured for an initial coverage of 6 zones (expandable to 24) to make a basic system; the devices for constructing and commissioning this basic system are as follows:

- 1 keypad with display art. 01705;
- 2 dual-technology surface-mounting detectors with anti-masking and anti-crawl detection art. 01721;
- 4 flush-mounting magnetic contacts art. 01820;
- 1 siren for outdoor use art. 01715.

**CAUTION:** Where there is a need for any configuration other than the default one, use the keypad 01705 or the By-alarm Manager software to view the parameter menu to change the settings according to the relevant installation requirements.

#### 3.1 Default settings

The control unit is configured as follows:

- Configured areas: **Area 1**
- Name assigned to Area 1: **Dwelling**
- Zones into which Area 1 has been divided: **6**
- Devices linked to zones and their configuration:

Zone No.	Zone name	Linked detector	Type of balancing and resistors	Detection modes
1	Entrance door	Magnetic contact art. 01820	Single - 3k3 Ω	Delayed (in 30 s, out 30 s)
2	Window 1	Magnetic contact art. 01820	Single - 3k3 Ω	Instant
3	Window 2	Magnetic contact art. 01820	Single - 3k3 Ω	Instant
4	Window 3	Magnetic contact art. 01820	Single - 3k3 Ω	Instant
5	-	-	-	-
6	-	-	-	-
7	Day sensor	Detector art. 01721	Triple - 3k3, 4k7, 15k Ω	Instant
8	Night sensor	Detector art. 01721	Triple - 3k3, 4k7, 15k Ω	Instant

- Relay 2 of the control unit: **System status** (Area 1 on)
- Installer code: **123456** (to change the configuration)
- User code: code 1=**111111** (with "administrator" profile)

#### 3.2 Connections to make

The following figures illustrate how to connect the devices for constructing the basic system.

##### SIREN FOR OUTDOOR USE 01715

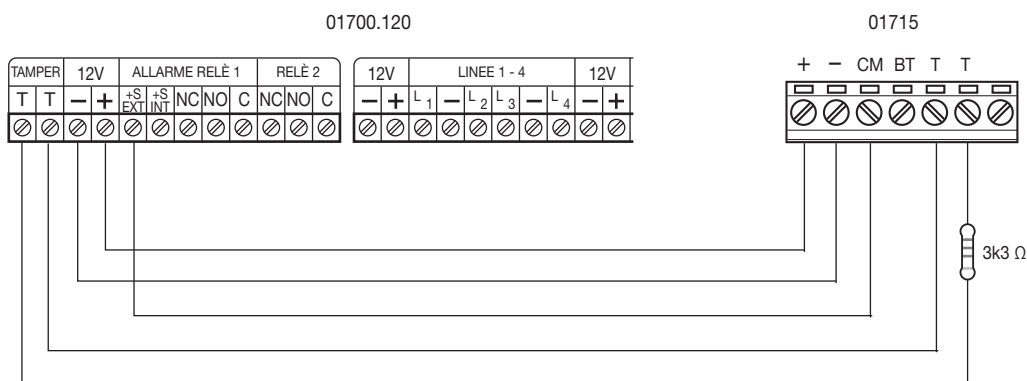

### MAGNETIC CONTACTS 01820

Single balancing is achieved by inserting a 3k3 Ω resistor in series with the contact.

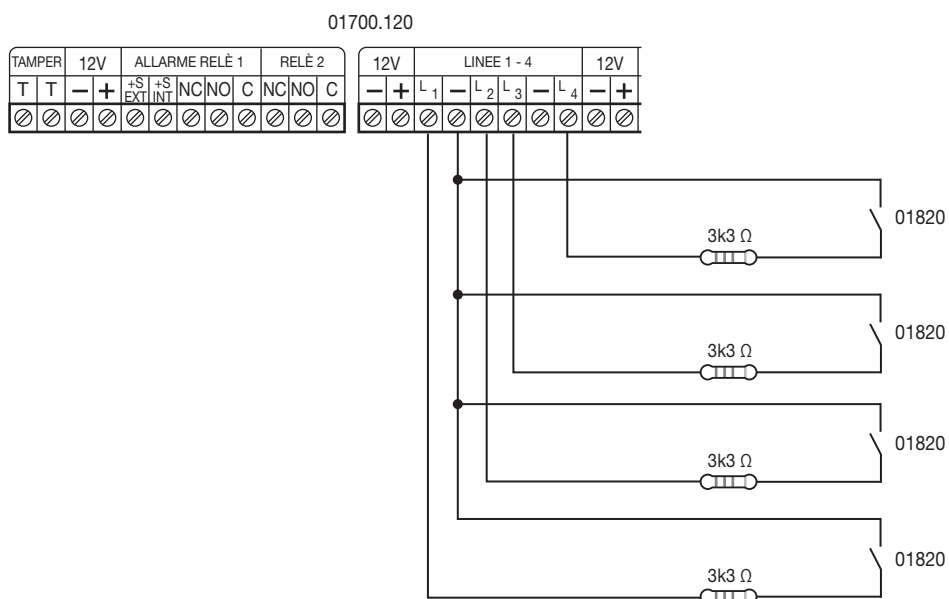

### DUAL TECHNOLOGY DETECTORS 01721

Triple balancing is accomplished by inserting the jumpers linked to the 3k3, 4k7 and 15k resistors on the detector.

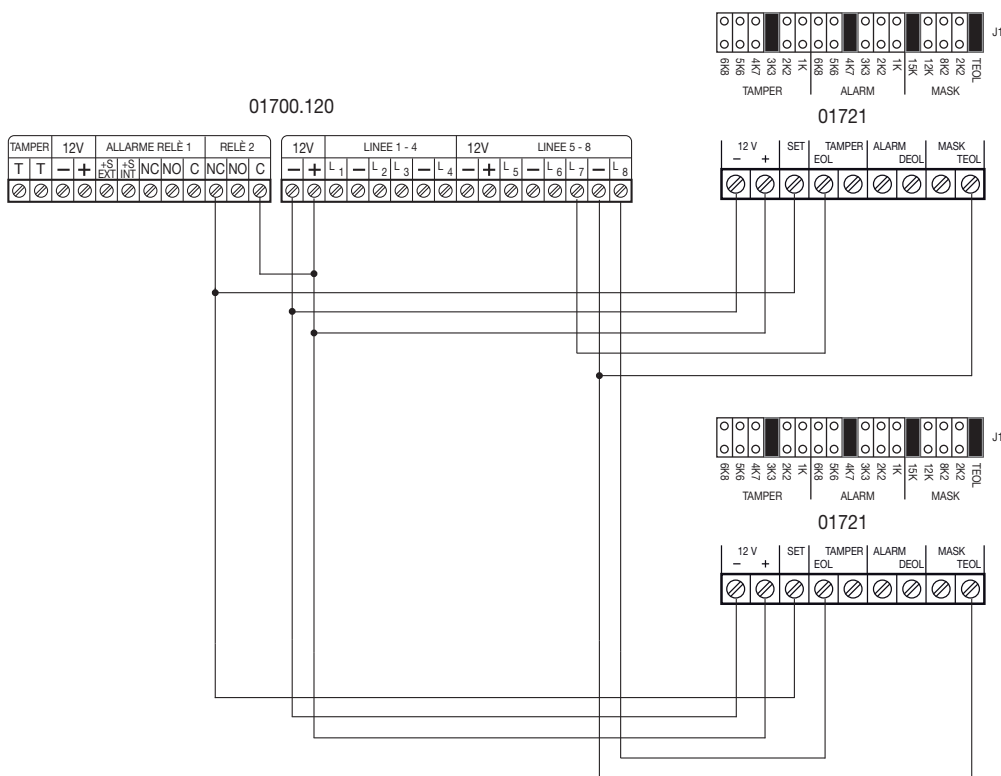

### 3.3 Operation

The control unit's default configuration provides for the following connection modes:

- ON = Total system activation.
- INT = Activation of zones 1, 2, 3 and 4.
- PAR = Activation of zones 1, 2, 3, 4 and 7.

## 4. Installation

### 4.1 Assembly

Fix the metal box to the wall using 4 screws attached to the 6 mm diameter wall plugs in the holes at the top and bottom corners of the rear wall of the box.

### 4.2 Control unit tear-proof device\*

To activate the tear-proof device use the spring supplied and a plug with screw.

Screw the screw in leaving a distance of approximately 10 mm between the wall and the screw head, as shown in the figure.

Slide the spring onto the tear-proof button and fit the metal box to the wall; then remove the jumper S1.

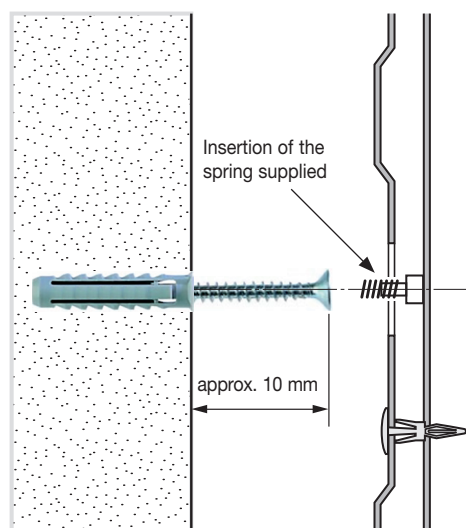

\* N.B.: For Grade 2 devices (EN 50131-3) the tear-proof function is optional.

### 4.3 Periodic maintenance

Periodic maintenance is required for the installed battery in compliance with the above tables.

When suitably programmed, the control unit can communicate the need to change the battery.

If the control unit has not been programmed to send communications relating to battery status, check the state of the battery charge once a year.

### 4.4 Compliance with regulations

EN 50131-3, EN 50131-6, EN 50131-10, EN 50136-2.

Direttiva BT. Direttiva EMC

Norme EN 60950-1, EN 50130-4, EN 61000-6-3.

### 4.5 Certification coverage EN 50131

**IMPORTANT:** For the EN 50131 certification not to elapse, it is necessary to ensure that all the system's devices are protected against tampering:

- see the relevant instructions for the detectors;
- for the expansion modules (art. 01709-01704-01710) and the isolated By-alarm interface (art. 01711), install the boards inside boxes equipped with anti-tamper and tear-proof devices such as the metal casing of the control unit (art. 01700.120) or of the additional power supply unit (art. 01717.120) or in the tear-proof box (art. 01714);
- if the system requires using additional power supply units (art. 01830), they must be installed in boxes equipped with anti-tamper and tear-proof devices and the input equipped with 3.3 k $\Omega$  balancing resistors must be taken to a line of the control unit or to a suitably configured input expansion modules (art. 01709 or 01704).
- for articles 01706 and 01708, the periodic communication must take place every 25 hours. To this end, program the SELF-TEST PERIOD parameter (Controls/Power Supply menu of the keypad 01705) to a value of 25 and then select the phone numbers for receiving the communication (Phone/Linked events/Self-test menu of the keypad 01705). For further details, please see the control unit programming manual.

### 5. Power supply unit

The control unit's power supply unit is stabilized on 13.8 V dc and delivers a current of 1.5 A.

Technical characteristics of the power supply unit		
Mains power supply	120 V~ (+10%, -10%) 60 Hz	
Stabilised voltage	rated 13.8 V dc ( $\pm$ 2%)	
Control unit absorption from the mains at 120 V~ -10%	with no load	51 mA
	maximum	225 mA
Control unit absorption from the mains at 120 V~ +10%	with no load	75 mA
	maximum	240 mA
Control unit absorption at 12 V dc	maximum	82 mA

#### 5.1 Cable entry

The mains power supply cables must enter through the hole nearest to the 120 V~ connection terminal block, to which they must be fixed without having been consolidated by soldering and they must have been inserted in advance into an additional sheath in order to ensure double insulation.

The connection to the electric mains must comply with the national plant engineering regulations and, in particular, in harmony with current standards, there must be an overcurrent circuit breaker with a high breaking capacity (1500 A) upstream of the connection to the control unit.

If other holes are used for routing the cables, it is necessary to use

cable outlets or junction fittings for pipe or sheath constructed with materials of flammability class HB or higher.

#### 5.2 Fuses

Input fuse 120V~:

F1: F3.15A - 250V

F2: F3.15A - 250V

F3: F3.15A - 250V

F4: F3.15A - 250V

F5: F3.15A - 250V

T 630mA-250V. Located directly on the mains voltage terminals.

ALTERNATING INPUT

BATTERY POLARITY REVERSAL

POWER SUPPLY FOR THE DETECTORS AND SIREN

COMMAND OF SIREN FOR INDOOR AND OUTDOOR USE

RS485 BUS LINE POWER SUPPLY

#### 5.3 Control unit earth connection

For the earth connection you need to use the specific terminal located under the transformer by the connection of its mains power supply; the cover should also be earthed, using the Faston terminal.

**Caution:** correct earthing protects the control unit and all its devices from faults caused by electrical and atmospheric discharges and in particular ensures the integrity of the telecommunications network.

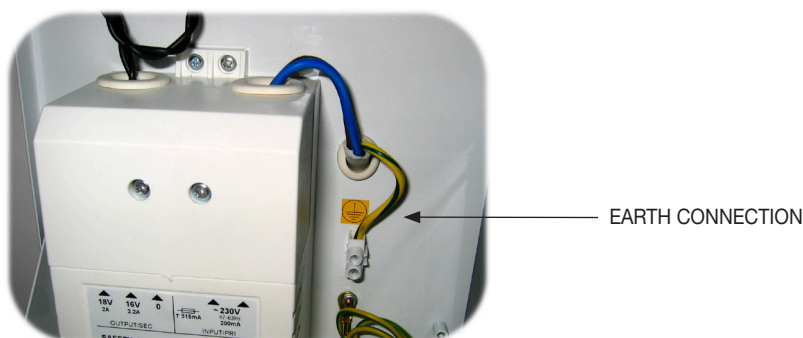

#### 5.4 Batteries

- The batteries used must be the 12 V sealed lead acid type with a minimum flammability class of V2.
- Suitable batteries: 12 Vdc 7.2 Ah or 12 Vdc 18 Ah.
- The cables for connecting the battery are designed for Faston connectors. For the screw connection, the Faston connector must be cut and eyelet terminals must be fixed to the ends of the cables.

**CAUTION:** DANGER OF EXPLOSION IF THE BATTERY IS REPLACED WITH ONE OF THE WRONG TYPE. DISCARD USED BATTERIES BY FOLLOWING THE INSTRUCTIONS.

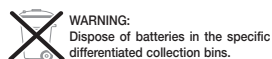

### 5.5 Operating current

The operating current and autonomy in compliance with EN50131 for external loads (guaranteed system autonomy 12h) depends on the battery for self-powering the control unit, according to the table below.

**Table 1 - Available current for systems complying to EN50131**

Internal battery of <b>7.2 Ah</b>	Available current for powering the system	500 mA
Internal battery of <b>18 Ah</b>	Available current for powering the system	500 mA

The maximum operating current for external loads is given in the following table and the maximum time for charging the battery to 80% capacity is 29 hours.

**Table 2 - Available current for non-compliant systems**

Internal battery of <b>7.2 Ah</b>	Available current for powering the system	1,120 mA
	Current for recharging battery	277 mA
Internal battery of <b>18 Ah</b>	Available current for powering the system	550 mA
	Current for recharging battery	847 mA

**Caution:** To guarantee compliance to EN50131 standard, it is necessary to keep to the values given in table 1.  
Failure to observe the above requirements invalidates the type approval.

**IMPORTANT:** If the previous requirements are not met it is possible to add to the system an additional power supply unit (art. 01717.120) equipped with an internal battery that enables redistributing the power supply for the devices and thus making the system compliant with EN50131.

### 5.6 Criteria for sizing the system

This subsection illustrates the flowchart with the criteria to follow for correctly sizing the system in relation to the desired autonomy and the consumption of the devices in the By-alarm system.

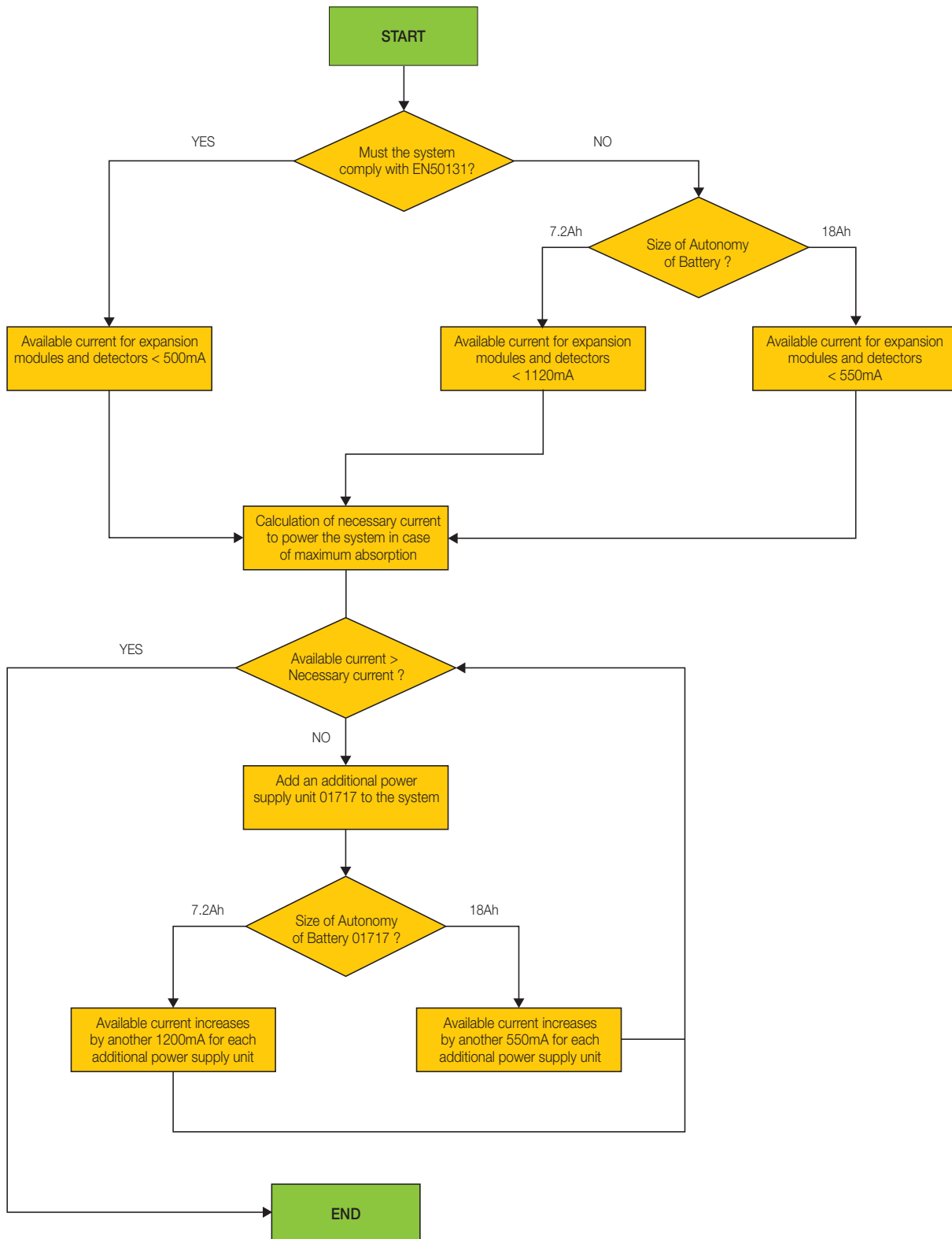

**CAUTION:** To size the system correctly you must always consider the maximum consumption; this condition varies according to the number of devices in the system and the configuration made.  
Generally, you should pay attention to the condition of total connection and alarm activated.

Table 3 - Devices in the By-alarm system and their consumption

Article	Description	Notes	Absorption
01704	8-input expansion module		18 mA
01705	LED backlit By-alarm keypad with display	Display on	105 mA
		Stand-by	16 mA
01706	GSM transmitter/receiver module	On a call	350 mA
		Stand-by	60 mA
01708	PSTN communicator	In operation	70 mA
01709	4-input expansion module		18 mA
01710	4-output expansion module	Max	83 mA
		Each active output increases the consumption by the value indicated alongside	17 mA
		To outputs that are not active	15 mA
01711	Isolated By-alarm interface		25 mA
01712	By-alarm interface to the Ethernet network		190 mA
01713.EN	Voice synthesis module		10 mA
01715	By-alarm siren for outdoor use	In an alarm condition (current supplied by the external battery)	1.5 A
		While charging the battery	60 mA
		Stand-by	30 mA
01720	Dual technology By-alarm detector, anti-masking detection, PET immune	Max	40 mA
		Stand-by	30 mA
01721	Dual technology By-alarm detector, anti-masking and anti-crawl detection	Max	40 mA
		Stand-by	30 mA
01722	Dual technology By-alarm curtain detector	Max	40 mA
		Stand-by	-
01723	By-alarm dual technology IP54 curtain detector for outdoor use	Max	70 mA
		Stand-by	60 mA
01724	By-alarm water detector		3.5 mA
01729	By-alarm radio frequency interface	Max with LEDs on	80 mA
		Max with LEDs off	40 mA
20478-19478-14478	By-alarm connector/partitioning	In the phase of reading	42 mA
		With LEDs off	20 mA
20479-19479-14479	By-alarm passive infrared and microwave presence detector	Max	28 mA
		Stand-by	15 mA
20496-19496-14496	By-alarm siren for indoor use	In an alarm condition	110 mA
		Stand-by	18 mA

### 6. Connecting the devices

#### 6.1 RS 485 serial link

The control unit is equipped with a serial port for connecting the RS485 bus of the devices such as, for instance, the keypads and the input and output expansion modules.

The RS 485 serial link uses the following connection signals:

- Serial power supply + and - at 12 V dc SELV
- Differential signals A and B
- DE direction enabling signal

The DE signal is only needed when the isolated By-alarm interface is inserted in the system for regenerating the RS485 bus signal (art. 01711); in this regard, note the difference between the 4-wire bus (+, -, A and B) and the 5-wire bus (+, -, A, B and DE).

**IMPORTANT: Do NOT connect the RS485 bus of the By-alarm system to that of the By-me system. An accidental connection could damage the system.**

- The wiring of the RS485 bus can be made with free topology and you can then make all the relevant shunting, however it is recommended to make a direct connection wherever possible.
- The maximum permissible length of the wiring is 600 m (the sum of all the lengths of bus laid out) or 1000 m if using the direct connection.
- The isolator/repeater module art. 01711 lets you expand the RS485 bus to get another 600 m of cable to use for the wiring.

#### EXAMPLE OF WIRING TOPOLOGY

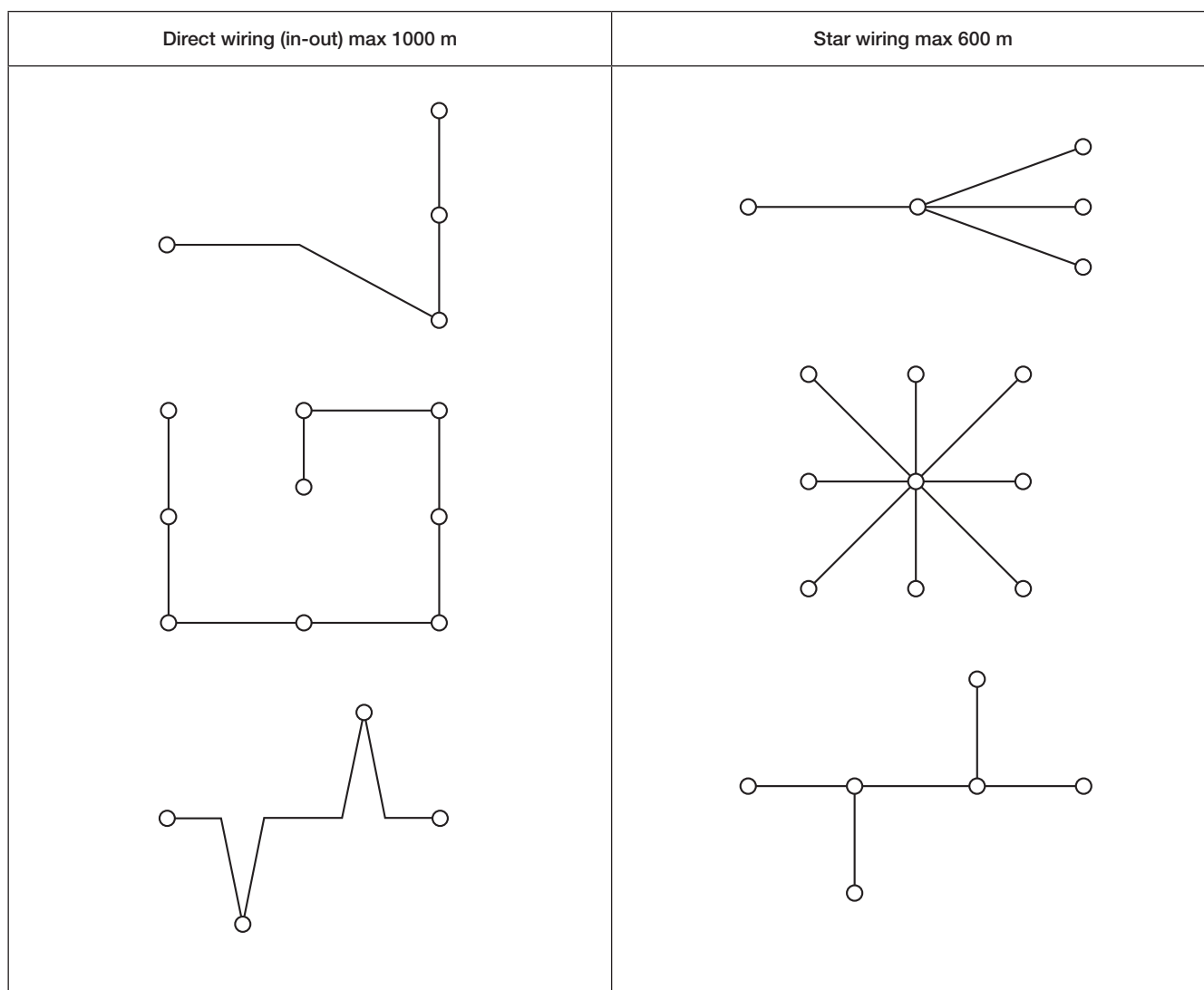

N.B. Even if the RS485 bus lets you make any kind of topological combination, it is advisable to use those with direct wiring as they provide a higher level of transmission performance.



## Connecting the devices

### 6.2 Connecting 4-wire devices

The various devices can be connected either on the RS485 bus or in parallel with the conductors, respecting the abbreviations on the terminals of the control unit and of the devices, ie:

- + with +
- - with -
- A with A
- B with B

The 12 V dc power supply requires using 0.50 mm<sup>2</sup> conductors and the signals A and B 0.22 mm<sup>2</sup>; the shielding must be connected to the negative terminal on the control unit side.

For the wiring, it is necessary to use halogen-free shielded cables suitable for installation with Category 1 power cables (U<sub>0</sub> = 400 V). The VIMAR connection cable articles to use for the RS 485 serial link and the wired connection of the devices are as follows:

- art. 01733 (2x0.50 mm<sup>2</sup>+2x0.22 mm<sup>2</sup>)
- art. 01734 (2x0.50 mm<sup>2</sup>+4x0.22 mm<sup>2</sup>)

**IMPORTANT:** The cable shield must be connected only at the end of the control unit or of the additional power supply and connected to the negative terminal of the supply voltage. The connection cables for the By-alarm system are compliant for routing with the power supply cables of the mains voltage; however, we recommend you to lay the connection cables in a dedicated raceway and avoid laying in parallel with the power supply cables and particularly with cables of inverters and loads such as pumps, burners, ballasts, motors, etc., especially for long distances.

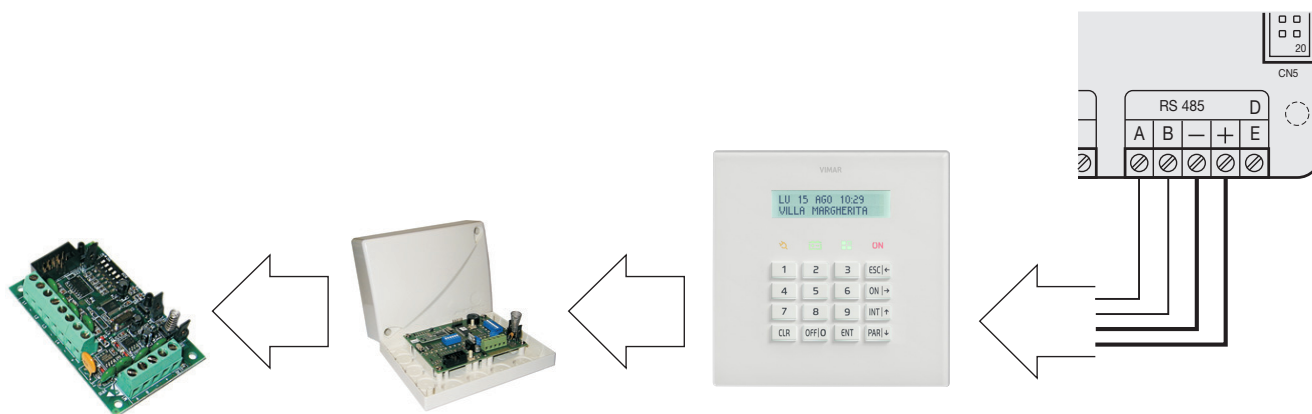

### 6.3 Connecting 5-wire devices

For connecting the 5-wire devices, the same requirements as for connecting the 4-wire devices apply, except for the following:

- The maximum length of wiring for the DE signal is 2 m for all devices except for the keypad (art. 01705) where the maximum length is 600 m.
- The various DE signals of the devices must NOT be connected together but must only be connected to the relevant terminal of the isolated By-alarm interface that can accommodate at most 6 of them.
- It is not possible to connect other devices with a 4-wire connection in the 5-wire stretches of bus.

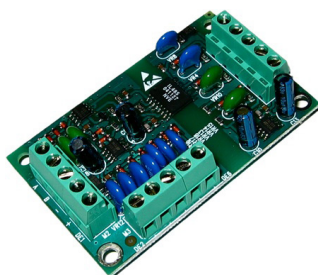

For all the details, please see the Annex in this manual on wiring.

### 7. Inputs

#### 7.1 Control unit

The control unit 01700.120 has 8 input lines, which can be configured individually for single, double and triple balancing. With double balancing it is possible, for each line and with only two wires, to have separate detection of the alarm and of tampering; whereas, with triple balancing it is possible to detect masking of the detectors as well. **Each input line corresponds to one zone of the system.**

In the same terminal block there are the 12 V dc power supply outputs of any detectors; both outputs are protected by a fuse **F3 - 3.15A 250V**.

Pay attention not to exceed the maximum absorption contemplated for each single power supply terminal.

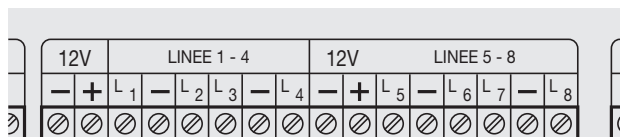

For the wiring of the wired detectors, it is necessary to use halogen-free shielded cables suitable for installation with Category 1 power cables ( $U_0 = 400\text{ V}$ ). The VIMAR connection cable codes to use for the wired connection of the devices are as follows:

- art. 01732 (2x0.22 mm<sup>2</sup>)
- art. 01733 (2x0.50 mm<sup>2</sup>+2x0.22 mm<sup>2</sup>)
- art. 01734 (2x0.50 mm<sup>2</sup>+4x0.22 mm<sup>2</sup>)
- art. 01735 (2x0.50 mm<sup>2</sup>+6x0.22 mm<sup>2</sup>)

- **IMPORTANT:** The cable shield must be connected only at the end of the control unit or of the additional power supply and connected to the negative terminal of the supply voltage. The connection cables for the By-alarm system are compliant for routing with the power supply cables of the mains voltage; however, we recommend you to lay the connection cables in a dedicated raceway and avoid laying in parallel with the power supply cables and particularly with cables of inverters and loads such as pumps, burners, ballasts, motors, etc., especially for long distances.

- The wiring of the detectors/contacts to the inputs, both directly in the control unit and in the expansion modules, must not exceed 100 m in a residential setting and 50 m in an industrial one.

**CAUTION:** We do not recommend connecting multiple contacts in series because you would lose the ability to distinguish the contact that may be open or tampered with. This recommendation applies all the more to detectors because, in addition to managing alarm signalling, they also signal tampering and anti-masking (double or triple input balancing) and this cannot occur if the devices are connected in series on the same input.

- **IMPORTANT:** The balancing resistors, if not already fitted, must be located in the enclosure of the wired detector.

#### 7.1.1 Anti-tampering

The terminals of the anti-tampering line of the control unit are marked TT. This line is dedicated to anti-tampering for various components in the system (sirens for indoor and outdoor use, etc.) and must be balanced with a 3.3 k $\Omega$  resistor (orange, orange, red).

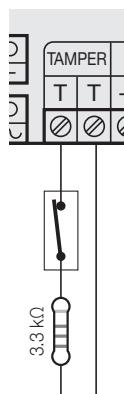

**N.B.:** • the anti-tampering line cannot be bypassed via the keypad and, so, must always have the balancing resistor.

- the push-buttons protecting against opening and against tearing the control unit off the wall that are located on the board can be temporarily bypassed by closing the respective jumpers alongside the buttons.
- if multiple devices are connected to the same tamper panel line, all the N.C. contacts must be connected in series and there must only be one balancing resistor of 3.3 k $\Omega$  or the sum of the resistors of the single devices must be equal to that value.

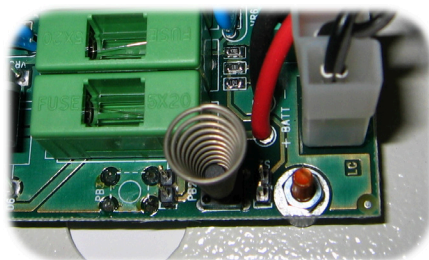

## Inputs

### Caution:

- Keying in the Installer Code inhibits every alarm, therefore also all the tamper-proof protections will be blocked.
- Bypassing a line via the keypad bypasses the zone's alarm detection function but not the related tamper-proof protection

### 7.1.2 Single balancing

When programming the line for single balancing, you need to connect a 3.3 kΩ resistor (orange, orange, red) in series with the normally closed contact. The single balancing configuration manages two different types of alarm and needs a line of the control unit and of the tamper input of the control unit itself; in the case of a tamper alarm, the warning will be generic and it will not be possible to distinguish which device has generated it.

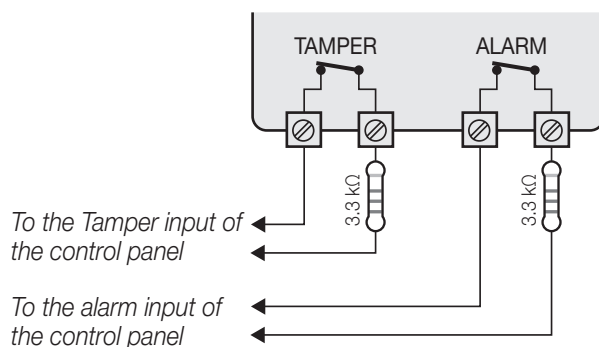

### 7.1.3 Double balancing

When programming the line for double balancing, two resistors must be connected, one of 3.3 kΩ (orange, orange, red) in series with the line and the other of 4.7 kΩ (yellow, purple, red) in parallel with the alarm contact. This configuration manages two different types of alarm and needs just one line of the control unit; in the case of a tamper alarm, it will be possible to identify the device that generated it.

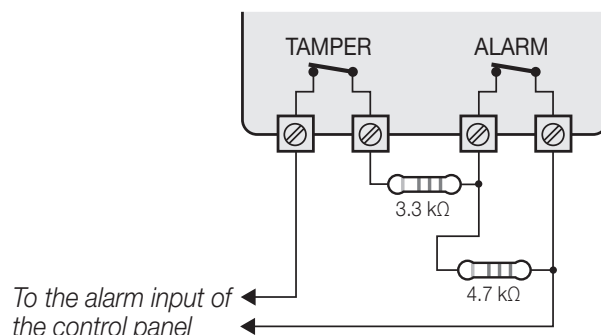

### 7.1.4 Triple balancing

If the detector is equipped with a masking detection output, it is possible to have the control unit recognize this status too; three resistors must be connected, one of 3.3 kΩ that detects tampering (orange, orange, red) in series with the line, another of 4.7 kΩ (yellow, purple, red) in parallel with the alarm contact and another of 15 kΩ (brown, green, orange) in parallel with the anti-masking contact. This configuration occupies just one line of the control unit and manages three different types of alarm.

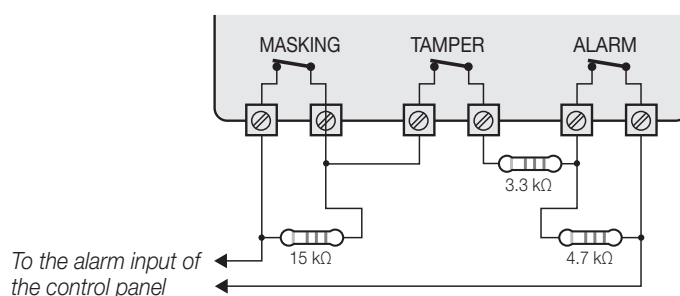

### 7.2 Input expansion module and radio frequency interface

- The input expansion modules 01709 and 01704 are connected to the control unit via the RS485 bus; this enables increasing the number of wired inputs above the 8 present in the control unit.  
The modules 01709 and 01704 are respectively equipped with 4 and 8 inputs that are individually configurable for single, double and triple balancing. For the wired connection between the input expansion modules and the detectors, the same considerations given in subsection 7.1 apply.
- The radio frequency interface 01729 is connected to the control unit via the RS485 bus; this enables integrating within the system all the radio devices such as the detectors 01727 and 01728 and the remote control 01730.  
Each interface 01729, depending upon how it is configured, can have 8 or 16 inputs.

### 7.3 Addressing the input expansion modules and radio frequency interfaces

Since both the input expansion modules and the radio frequency interfaces belong to the category of devices that occupy the wired zones that can be managed by the control unit (up to 24), it is necessary to address the lines correctly in relation to the number of modules 01709, 01704 and interfaces 01729 installed in the system.

To address the lines correctly, bear in mind the following:

- There are 8 control unit input lines and therefore the addresses from **1 to 8 are exclusive** of these lines (even if some of them are not used).
- The addresses assigned to the input lines of module 01709 or 01704 or interface 01729 thus start from 9 upwards.
- The input lines of modules 01709 or 01704 or the interface 01729 **must always have different addresses**.
- The addresses of the input lines of modules 01709, 01704 and interface 01729 that are not used must in any case be counted.
- The total addresses of the input lines can reach up to 24.

#### ADDRESS EXAMPLES

1) Suppose you have a system containing the control unit 01700.120 to which are connected in succession:

- 1 input expansion module 01709;
- 1 radio interface 01729 configured with 8 inputs.

The addresses to assign will be the following:

- ID=1 for module 01709 whose input lines will be 9-10-11-12
- ID=2 for radio interface 01729 whose input lines will be 13-14-15-16-17-18-19-20

2) Suppose you have a system containing the control unit 01700.120 to which are connected in succession:

- 1 input expansion module 01704;
- 1 radio interface 01729 configured with 8 inputs.

The addresses to assign will be the following:

- ID=1 for module 01704 whose input lines will be 9-10-11-12-13-14-15-16
- ID=2 for radio interface 01729 whose input lines will be 17-18-19-20-21-22-23-24

3) Suppose you have a system containing the control unit 01700.120 to which are connected in succession:

- 1 input expansion module 01704;
- 1 input expansion module 01709.

The addresses to assign will be the following:

- ID=1 for module 01704 whose input lines will be 9-10-11-12-13-14-15-16
- ID=1 for module 01709 whose input lines will be 17-18-19-20

4) Suppose you have a system containing the control unit 01700.120 to which are connected in succession:

- 1 radio interface 01729 configured with 16 inputs;

The addresses to assign will be the following:

- ID=1 for radio interface 01729 whose input lines will be 9-10-11-12-13-14-15-16-17-18-19-20-21-22-23-24.

**CAUTION:** The assigned ID addresses are also those to which reference must be made when the By-alarm Manager software or keypad 01705 are used. For example, if an interface 01729 has been assigned ID=1 and an input expansion module 01709 ID=2, when you enter the menu *CONFIGURATION- BUS PROGRAMMING* of the keypad you need to key in bus address "1" for the interface 01729 and "2" for the input expansion module 01709.

## Outputs

### 8. Outputs

The control unit has two alarm output relays with independent programming.

#### 8.1 Relay 1 output

This is a positive safety relay, with double exchange, with 1A capacity each. A voltage free exchange is provided at the output where C is the common, NC is the normally closed exchange and NO is the normally open one; the other one is provided already polarized for connecting the self-powered sirens and the optional non-self-powered internal sirens.

The following figure illustrates the internal connection of the terminals to the board as described above:

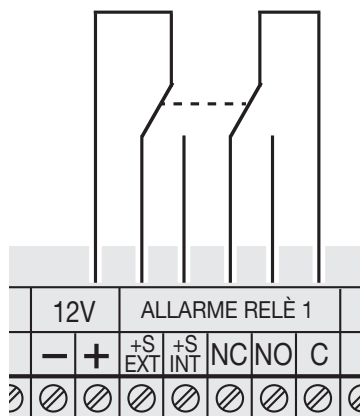

-/+ : power supply for recharging the batteries of the self-powered sirens; the positive is protected by the 3.15A 250V fuse F3.

+S ext: command positive for the self-powered sirens; it constantly provides a positive which fails in the event of an alarm and is protected by the 3.15A 250V fuse F4.

+S int: power supply positive for the optional non-self-powered sirens; it provides a positive in the event of an alarm and is protected by the 3.15A 250V fuse F4.

#### EXAMPLE OF CONNECTING THE CONTROL UNIT WITH THE SIREN FOR OUTDOOR USE 01715

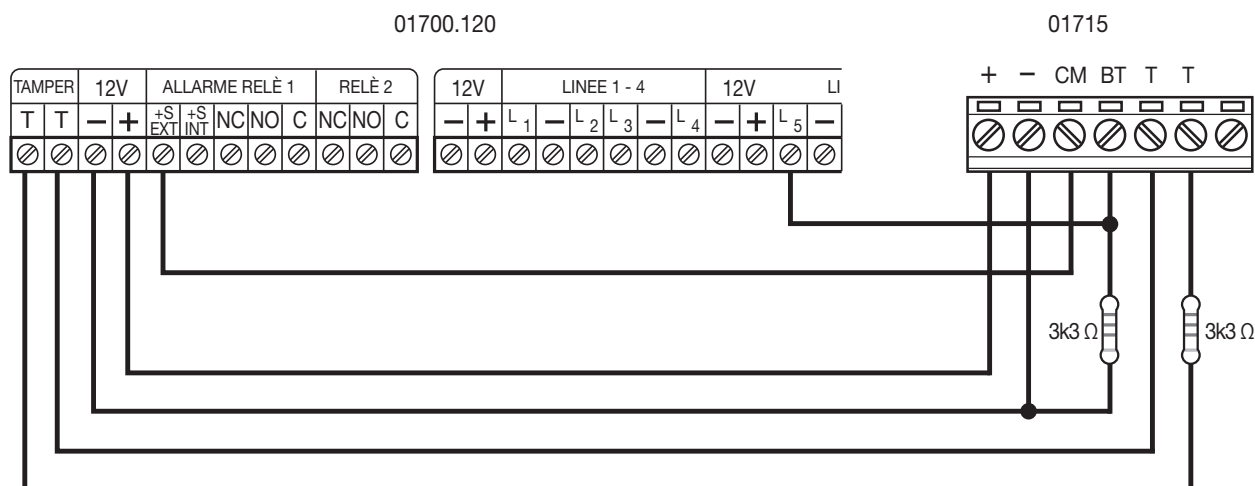

**N.B:** The siren's BT output can be connected to any input of the control unit or an input expansion module 01704 or 01709 (input L<sub>5</sub> of the control unit has been used in the figure).

EXAMPLE OF CONNECTING THE CONTROL UNIT WITH THE SIREN FOR INDOOR USE 20496-19496-14496

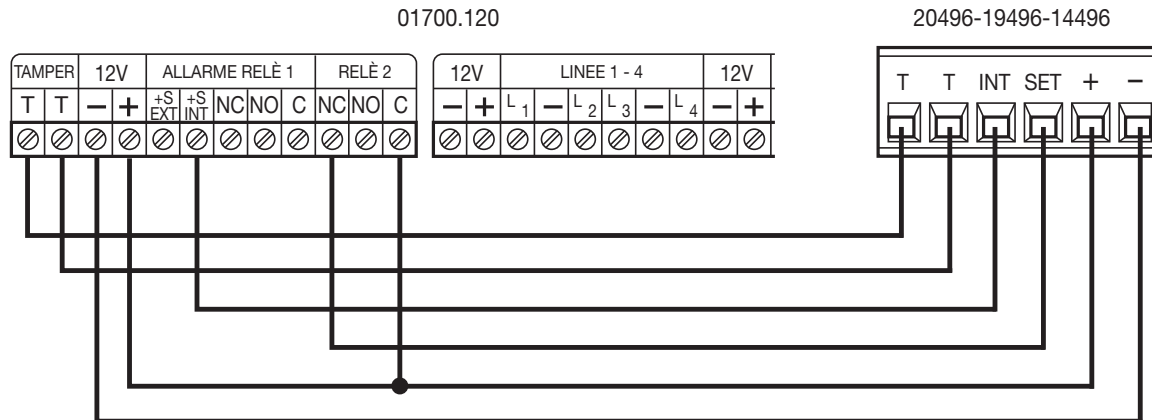

EXAMPLE OF CONNECTING THE CONTROL UNIT WITH THE SIREN FOR OUTDOOR USE 01715 AND THE SIREN FOR INDOOR USE 20496-19496-14496

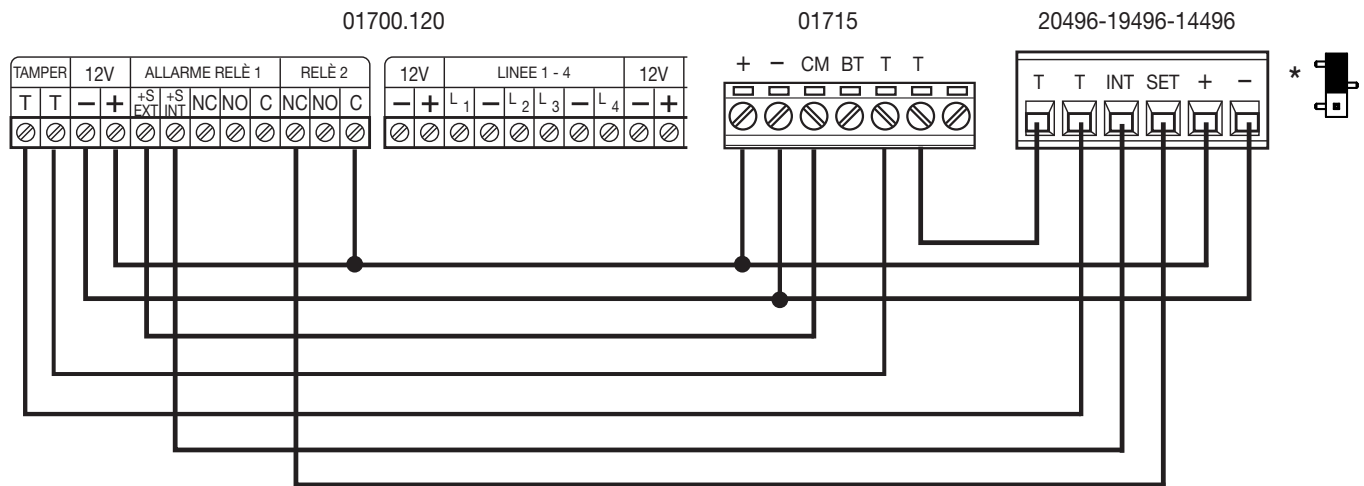

\* Jumper D closed on 1 and 2

### 8.2 Relay 2 output

This is a non-positive safety relay, with exchange with 1A capacity. The voltage-free exchange is provided at the output where C is the common, NC is the normally closed exchange and NO is the normally open one.

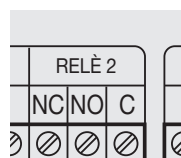

### 8.3 CN10 connector

Spare terminal.

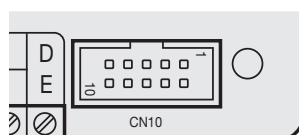

### 9. PSTN communicator 01708

#### 9.1 PSTN communicator 01708

The device is a printed circuit board to be combined with the control unit to which it is to be connected by a flat cable connector, supplied; in this way it will be possible to send any fault or alarm communication over the telephone line.

It can be programmed directly via the keypad connected to the control unit or through the phone line with an interactive connection.

Available communication protocols include:

- 1) SIA standard for communications with reception equipment.
- 2) Contact ID for communications with reception equipment.

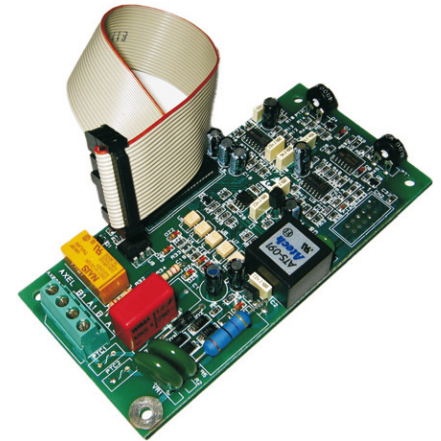

#### 9.2 Inserting the board in the control unit

##### Installation

The dialler's board should be secured and locked on the bottom of the control unit enclosure using the spacers, supplied, alongside the control unit's printed circuit board.

The board should be firmly secured with screws on the threaded turret; this ensures adequate electrical continuity between the earth and the negative of the board.

**Caution:** The trimmers PT1 and PT2 on the digital communicator's board are set in the factory and must not be rotated for any reason whatsoever.

##### Connections

The following instructions must be followed meticulously:

- a) Cut off all electrical power to the control unit.
- b) Plug the telephone dialler's connector into the recessed connector (CN5) alongside the board of the control unit.
- c) Connect the terminals A and B to the external telephone line, upstream of all the telephone devices.
- d) Connect the terminals A1 and B1 to the internal phones.
- e) Restore power to the control unit by connecting the mains voltage and the self-powering battery of the control unit.

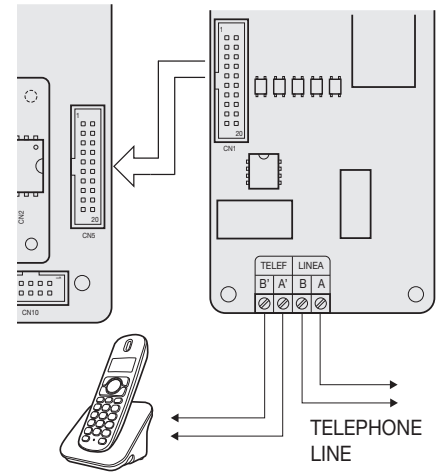

### 10. Voice synthesis module 01713.EN

#### 10.1 Voice synthesis module 01713.EN

Electronic circuit for managing voice synthesis messages to send over the telephone line; in this way it is possible to send all communications for alarms, faults or failures automatically to any phone number, by means of pre-recorded messages already included in the control unit.

The user can also query the control unit by means of an ordinary telephone to know the status of the lines and alarms, switch the control unit off and on (if enabled), cut off zones and cut them back in, check and change his/her telephone numbers, activate and deactivate the active outputs and activate the macro commands.

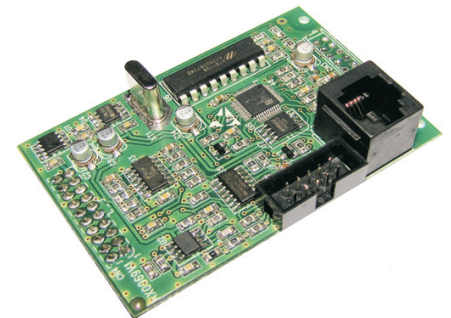

#### 10.2 Inserting the module in the control unit

##### Installation

The voice synthesis board should be inserted directly on the control unit's board by aligning the special connector on **CN4**.

- 1) Insert the board by aligning the module connector with that on the board of the control unit.
- 2) Gently press until fully seated, locking the board with the special spacers.

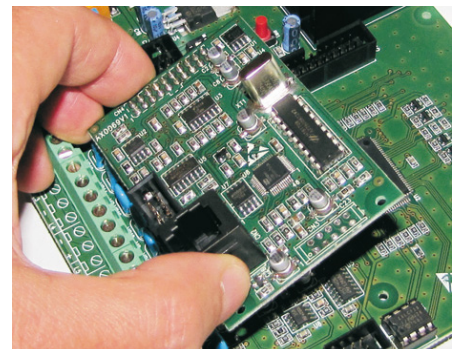

### 10.3 Recording synthesis messages

#### Note

The message to be recorded is related only to the user addresses because all possible alarm, fault or failure communications are already pre-recorded and entered in the dialler.

- Insert a standard telephone appliance with DTMF in the plug of the voice synthesis module.
- Keying the installer code on the keypad takes you into programming mode.
- Enter the telephone programming menu: VOICE MESSAGE, choose which message to record and stop at RECORD.

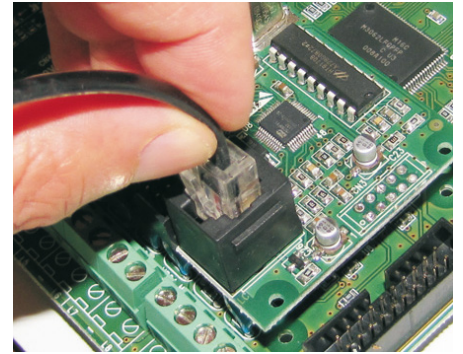

#### Method 1 - With the phone's keypad

- Lift the telephone's handset and press KEY 8 to activate the record command.
- From the moment when you press the button, the recording time starts which has a maximum length of 10 seconds; the display of the keypad will also show the passage of time.
- At the end of the message, press KEY 0 on the phone's keypad; in this way you stop recording.
- To listen to the message, press KEY 5 on the phone's keypad.

If the recording is not satisfactory, you can repeat the entire procedure, resuming it from point d).



#### Method 2 - With the keypad 01705

- Press the ENT button on the control unit's keypad to activate the record command.
- From the moment when you press the button, the recording time starts which has a maximum length of 10 seconds; the display of the keypad will also show the passage of time.
- Speak into the phone's microphone and, at the end of the message, press the ENT button again; in this way you stop recording.
- To listen to the message, go to the programming menu: LISTEN and press ENT.

If the recording is not satisfactory, you can repeat the entire recording procedure, resuming it from point d).





## GSM transmitter/receiver module 01706

### 11. GSM transmitter/receiver module 01706

#### 11.1 GSM module 01706

The control unit can be equipped with a GSM module that enables automatically sending all alarm, failure or fault communications to any telephone number, with different methods of communication.

The module inserted directly on the control unit's board enables sending communications with:

- Contact ID standard protocol for digital signalling with reception and surveillance centres.
- SMS text message to mobile phones; the messages, already entered into the module, allow for the communication of any event on the control unit.
- If the voice synthesis module 01713.EN is also installed, it can also signal all events vocally.

The module also lets the User activate the RFA-SMS function, that can be used for telemanagement of the control unit via simple SMS text messages.

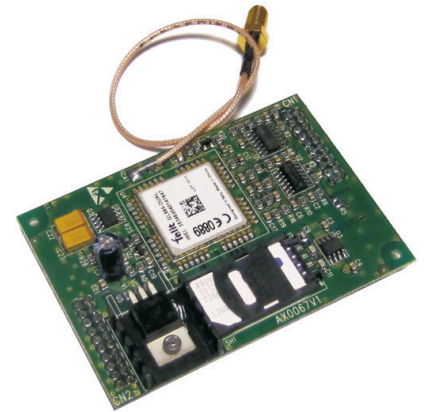

#### 11.2 Inserting the module in the control unit

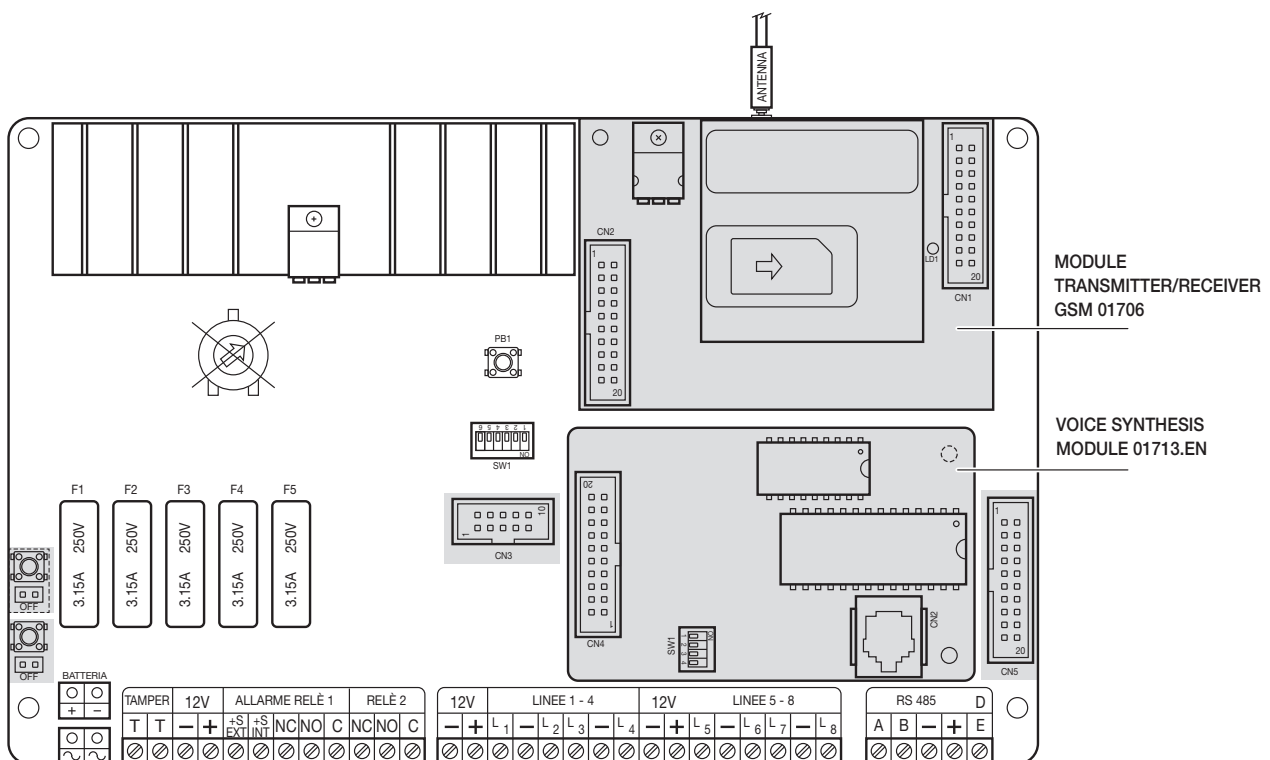

#### 11.3 Inserting the GSM module in the control unit

##### Installation

The circuit of the module **01706** has to be inserted directly on the board of the control unit by aligning the special connectors on **CN1** and **CN2**.

- 1) Insert the board by aligning the module connectors with those on the board of the control unit.
- 2) Gently press until fully seated, locking the board with the special spacers.

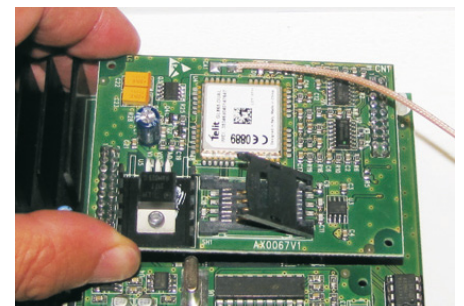

## GSM transmitter/receiver module 01706

### 11.4 Connecting the aerial

The aerial must be secured outside the enclosure, screwing it tight.

**Caution:** The aerial must not be left free or the interference generated by the GSM transmission could interact with the operation of the control unit.

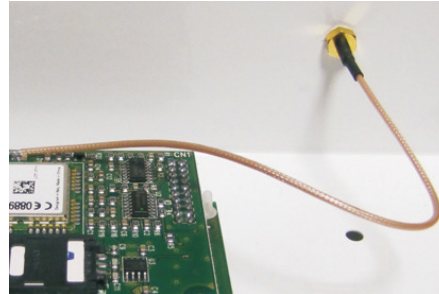
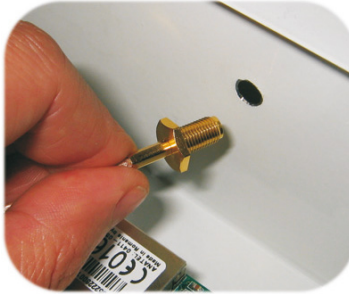

### 11.5 Installing the SIM

In order to prevent potential faults, completely disconnect the power supply to the control unit before inserting the SIM card into the slot.

a) To insert or replace the SIM, you need to open the slider by moving the catch securing it on the bottom to the right.



b) Insert the SIM fully into the slider.

c) Close the slider by lowering it completely and fasten it by moving the catch to the left.

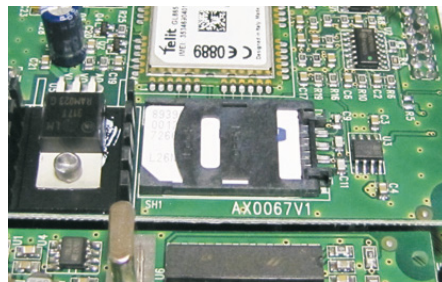

### 12. Connector 20478-19478-14478

#### 12.1 General information

The connector uses a recognition system with a unique code based on transponder technology to restrict and control access and operation; the reading key, sealed and with no battery, is maintenance free.

Completely integrated with the functions of the control unit, it improves the user friendliness of the systems while keeping unchanged the high standards of safety. Its operation is guided by audible warnings that facilitate performing the operations correctly, which is confirmed by the luminous signals of the LEDs on the connector.

Characteristics	
Reading range	• 0.5 cm.
Power supply	• 12 V dc ( $\pm 20\%$ )
Absorption	• 20 mA max with LEDs off • 42 mA max when reading
Conductors	• min. (2 x 0.50 mm <sup>2</sup> + 2 x 0.22 mm <sup>2</sup> ) shielded

#### 12.2 Operation

The connector senses the approach of a reading key and, after recognizing the user, it verifies the power status, shows the circuit test status with the green LED and the system power status with one of the red LEDs.

A courtesy light indicates, even in the dark, the reading point on which the key must be placed.

N.B. The colour of the courtesy light depends on the residential series installed:

- for the Eikon series, amber;
- for the Arkè series, blue;
- for the Plana series, green.



- Circuit test
- Switching ON
- Switching to INT
- Switching to PAR
- Courtesy light

#### Switching ON

Keeping the key on the reading point causes the three red LEDs to light up in sequence. When the LED corresponding to the desired arming mode lights up, move the key away to confirm switching on the control unit. If correctly programmed, the LEDs will automatically switch off after approximately 2 seconds.

#### Switching OFF

Keeping the key on the reading point switches off the red LED corresponding to the active arming mode; as a result the control unit will switch off.

**Caution:** In the event of a malfunction signalled by the connector, you need to go to the keypads to retrieve the pertinent information.

#### 12.3 Connections

- Up to 4 connectors can be connected to the RS485 bus, taking care to observe the abbreviations on the terminals of the control unit and of the connectors, ie A with A, B with B, etc.
- The power supply requires using conductors of at least 0.50 mm<sup>2</sup> and the shielding must be connected to the negative terminal on the control unit side only.



### 12.4 Addressing the connectors

The 4 different possible connectors must be addressed with a different address, like any other device connected to the RS485 bus of the control unit.

**IMPORTANT: If there is only one connector you must always give it address 1.**

To address each single connector you need to follow this procedure:

- Completely power down the control unit.
- Connect the connectors to the RS485 bus as described above and power up the control unit.
- Press the **RESET** button located on the side of the connector.
- Release the **RESET** button and immediately afterwards press and hold the **PROG** button for approximately one second. All the LEDs will light up alternately and the buzzer will emit a long beep.
- The combination of the lit LEDs shows the current addressing of the connector.
- Each time the **PROG** button is then pressed the address of the connector will increase as shown in the table below.
- Once you reach the desired address, you need to press the **RESET** button for one second to confirm the programming.



- Red ON LED
- Yellow INT LED
- Blue PAR LED
- Green status LED
- Courtesy LED

Connec- tor	LED				
	ON	INT	PAR	Green	Courtesy
1	OFF	OFF	OFF	OFF	OFF
2	ON	OFF	OFF	OFF	OFF
3	OFF	ON	OFF	OFF	OFF
4	ON	ON	OFF	OFF	OFF

**Note:** You need to choose a possible address, according to the control unit to which the connector is connected.

## Control unit hardware reset

### 13. Control unit hardware reset

#### 13.1 Reset button

Pressing the reset button PB1:

- 1) Stops any ongoing alarm with the related phone call and cancels all pending phone calls.
- 2) Does not alter the programming of the control unit in any way.

#### 13.2 DIP-switch SW1

SW1: default position					
1	2	3	4	5	6
				ON	
OFF	OFF	OFF	OFF		OFF

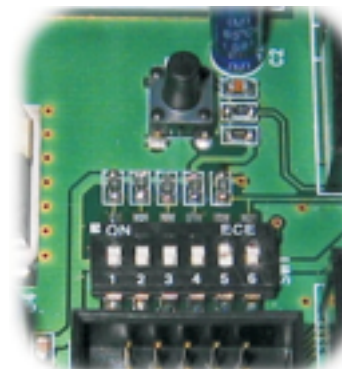

#### 13.3 Resetting the Codes

To reset the Codes you need to perform the following procedure:

- a) Set switch 1 of DIP-switch SW1 to ON.
- b) Press and release the reset button PB1.

SW1: position of DIP-switch during the reset procedure					
1	2	3	4	5	6
ON				ON	
	OFF	OFF	OFF		OFF

- c) After approximately 3 seconds the ALARM relay will start to switch on and off.
- d) Set the switch 1 back to OFF, as in the original position.
- e) Press and release the button again.

SW1: position of DIP-switch at the end of the reset procedure					
1	2	3	4	5	6
				ON	
OFF	OFF	OFF	OFF		OFF

Performing this reset again causes the following changes to the programming and status of the control unit:

- 1) The Installer's code and all the User Codes are thus taken back to their default values; the table alongside shows the values of the first 15 codes.

	User 1	User 2	User 3	User 4	User 5
Installer	111111	222222	333333	444444	555555
	User 6	User 7	User 8	User 9	User 10
123456	666666	777777	888888	999999	000000
	User 11	User 12	User 13	User 14	User 15
	100000	100100	100200	100300	100400

- 2) Just one keypad is enabled, the one with the address on one.
- 3) The telephone is disabled.
- 4) The control unit is switched off for all the AREAS.

#### 13.4 General reset

For the general reset to the factory values, you need to go into control unit programming mode with the Installer Code and carry out the *Default Reset* of the dedicated menu.

**CAUTION:** This operation will take the control unit back to its default configuration in which there is an initial coverage of 6 zones (for full details, please see chap. 3).

## Setting the English language

---

### 14. Setting the English language

To set English on the control unit and on the keypads 01705, carry out the following procedure:

- a) Set switch 3 of DIP-switch SW1 to ON.
- b) Press and release the reset button PB1.

SW1: position for the English language					
1	2	3	4	5	6
		ON		ON	
OFF	OFF		OFF		OFF

The changes concerning the display of the menus in the set language do not affect the custom names (for example, zone name, area name, system name, etc.). If you want to replace the custom names with the default names in English, you need to *Reset the Programming of the control unit to the default values* using the keypad (for details, please see the relevant programming manual).

To set the Italian language, starting from the English one, simply repeat the above procedure by setting switch 3 of DIP-switch SW1 to OFF.

## Interfacing with the By-me system

### 15. Interfacing with the By-me system

#### 15.1 Connection diagram

With the Ethernet interface (art. 01712) and the By-me Web Server (art. 01945 or 01946) you can interface the By-alarm burglar alarm system with the By-me automation system.

The burglar alarm control unit (art. 01700.120) interfaces with the web server via a special encrypted communications protocol with an extremely high degree of security; the web server, besides providing the user with the graphic interface for managing the control unit, also performs the function of a gateway towards the By-me system. The web server, moreover, lets installers access the system remotely via a secure communications channel, using the By-alarm Manager software.

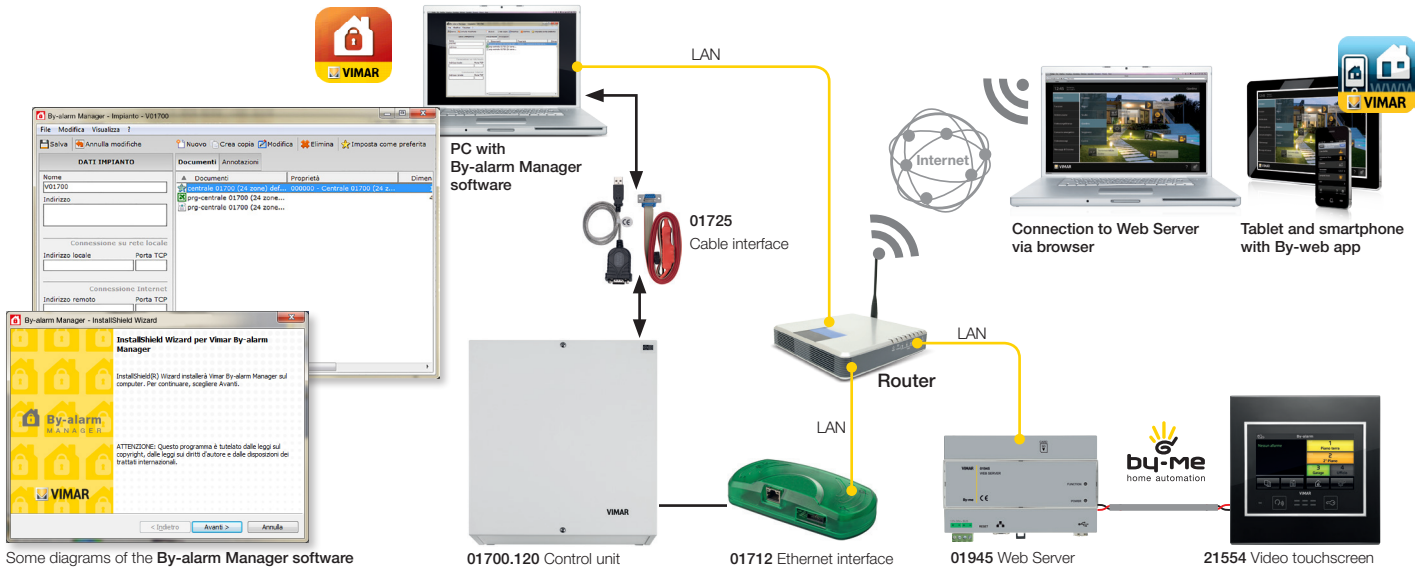

**N.B.:** If only the burglar alarm system is present without the By-me one, the connection via PC (on which the configuration/maintenance software is installed) will be made only through the serial link. On the contrary, if the web server is present, the installer can connect the PC to it both remotely and locally.

Two important features are possible with this type of interfacing:

- Integration of the By-alarm burglar alarm system with the By-me home automation system.
- Local and remote maintenance using the configuration software and secure connection via the web server.

#### 15.2 Integrating with the By-me system

The functions of integration between the burglar alarm system and the By-me system are the following:

- Possibility of controlling and supervising the By-alarm system via the Web Servers (art. 01945 and 01946), touchscreens (21511.1, 21554, 21553.1/2) and the home automation module (art. 01965) for the Arké video entryphone (art. 19558).  
With these devices it will be possible to view the system status, connect/disconnect areas according to the privileges of the user PIN entered and view the events/alarms.
- Possibility of controlling the lights via burglar alarm detectors, ie using the dual technology detectors to control the By-me light groups when the relevant zones are not connected (this function is to be configured on the web server).
- Possibility of using the window contacts to send the standby command to the By-me thermostats (this function is to be configured on the web server).
- Possibility to activate a By-me scenario on the occurrence of an event (connection, disconnection, alarms, etc.) in the intrusion detection alarm system (this function is to be configured on the web server).
- Possibility to use the By-me logic unit (art. 01468) to create logic programs linked to the status of the areas (total or partial connection, alarm).

#### 15.3 Local and remote maintenance via the By-alarm Manager software

The connection with the web server lets you perform both local and remote maintenance operations, with a secure connection, using the burglar alarm system software. This operation must be enabled by the user via a specific menu on the web server in order for the installer to maintain full control over access to system programming/maintenance.

**ANNEX**



### I. Wiring

#### I.1 Indications for correctly making the system earth connection and the Structured Cabling.

For the By-alarm system to work properly it is necessary to pay attention to the system's earth connections, ie:

- avoid installations that generate earth currents circulating in the system;
- star point connected earth conductors and connection of the building to earth at a single point (with system contained within 100 m of laying cables);
- use a structured cabling system if the system's dimensions exceed the safety distances for the use of a star point earth connection.

The structured cabling ensures a correct installation when the star connection of the earth conductors is not feasible; in particular, it is necessary when the system has the following classifications:

- Installations on a single building for system dimensions greater than 100 m such as, for example, apartments on different floors, detached houses, shopping malls and small industrial sheds where multiple additional power supply units (art. 01717.120) are installed.
- Installations distributed over multiple buildings such as, for example, detached houses with outbuildings, factories with multiple buildings and warehouses.

If the system comes within one of the above classifications, it is necessary to galvanically isolate two sections of RS485 bus, using the By-alarm interface art. 01711.

The system's classification then determines the type of insulation needed:

- for **Installations on a single building** wiring is used with **Reverse insulation**;
- for **Installations distributed over multiple buildings** wiring is used with **Double insulation**.

The following flowchart gives indications to identify the correct type of wiring according to the system's topology.

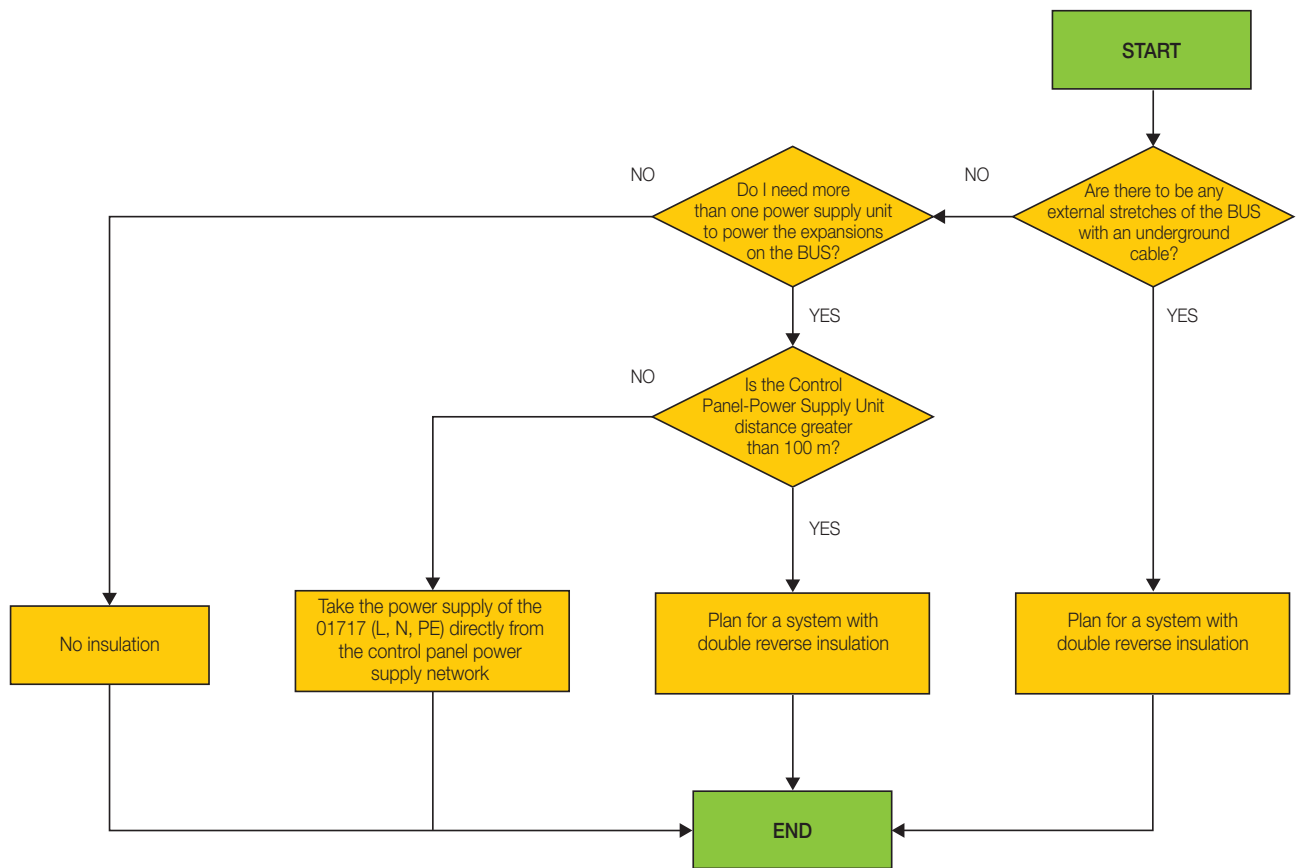

### I.II Outline for non-insulated multi-power supply wiring

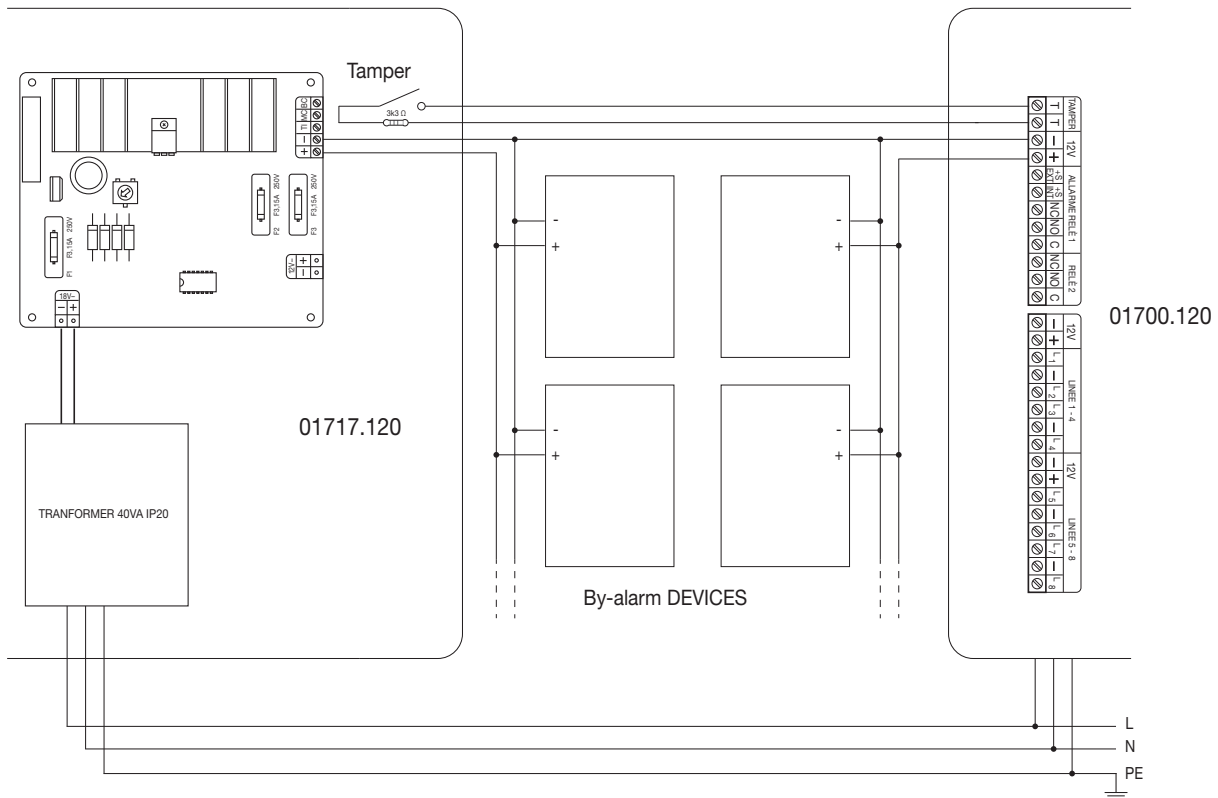

### I.III Outline for reverse insulation wiring.

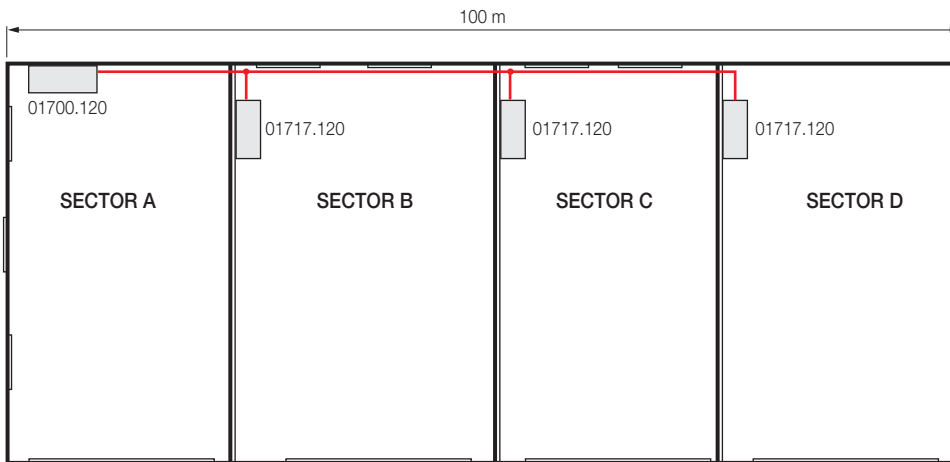

PLAN OF AN INDUSTRIAL SHED CONSISTING OF 4 SECTORS

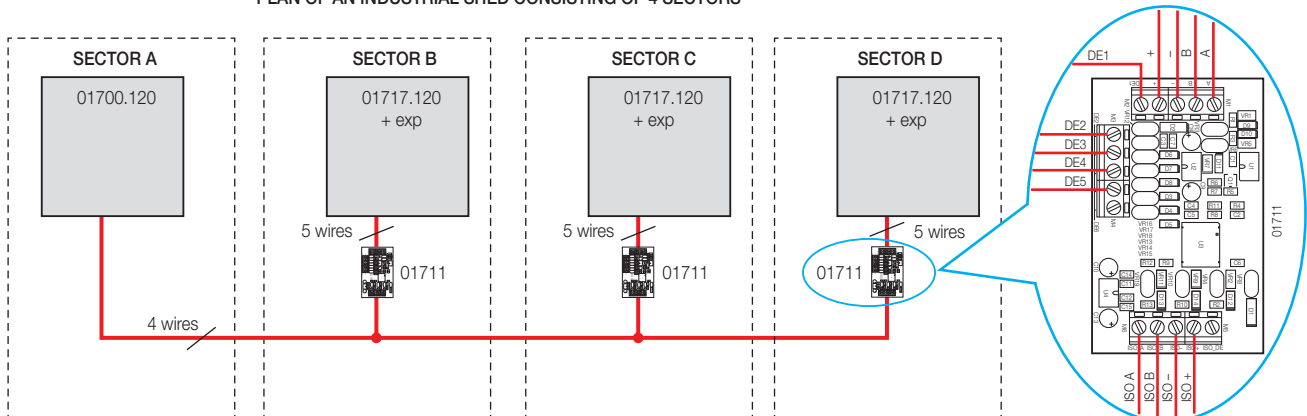

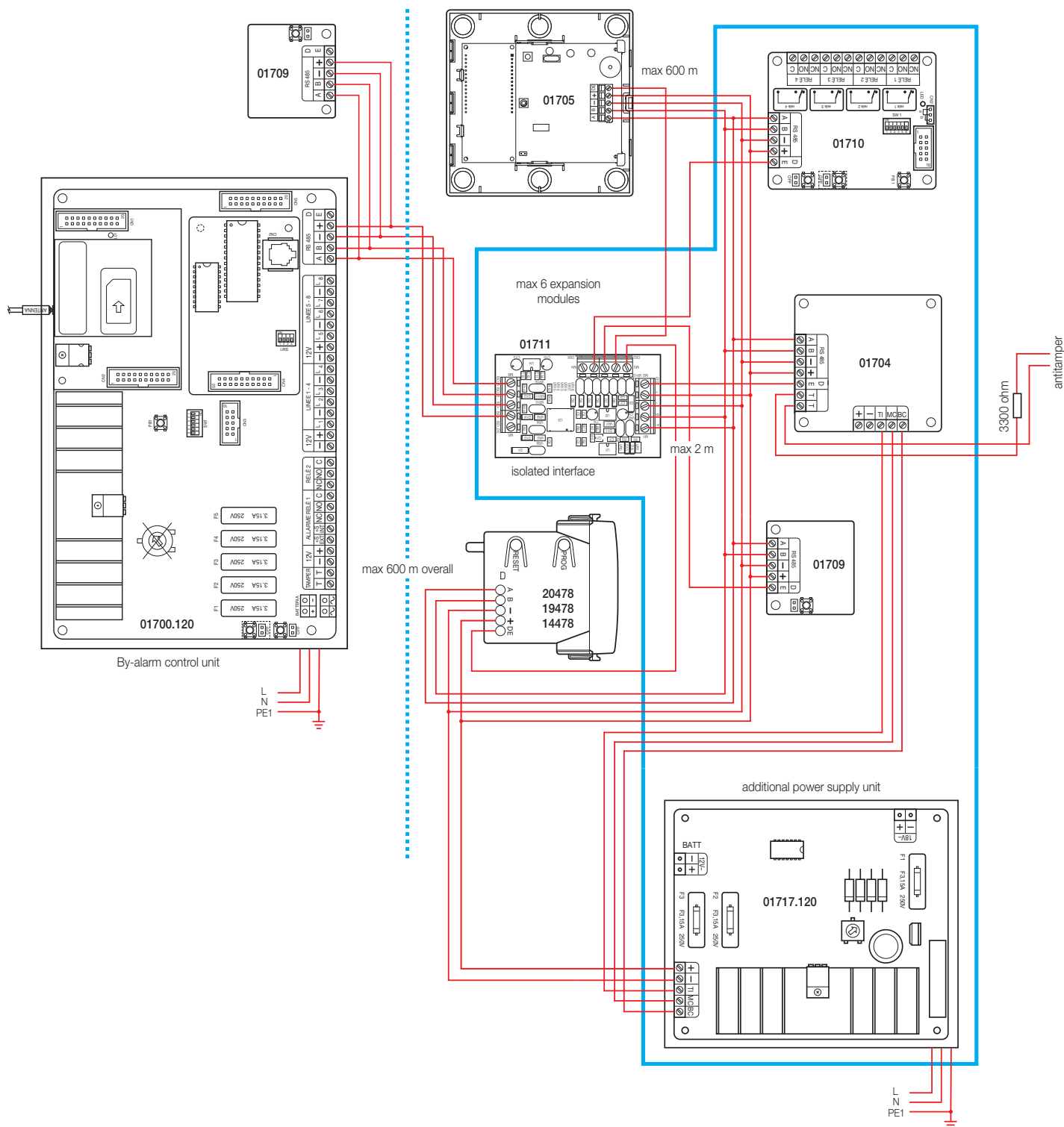

N.B. If there are no 8-input modules 01704, the tamper-proof signal with balancing resistance 3.3 kΩ must be carried to a 4-input expansion module 01709.

**IMPORTANT:**

- Reverse insulation is to be used only for connections inside the same building and when the cables of the alarm system are not underground.
- Do not connect the DE signals of the different devices together, but use the special terminal of the isolated interface 01711.

### I.IV Outline for reverse insulation double wiring

INSTALLATION DISTRIBUTED  
OVER MULTIPLE BUILDINGS

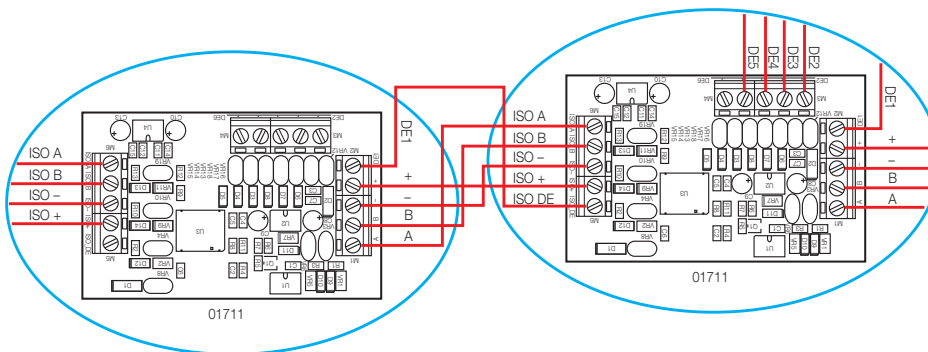
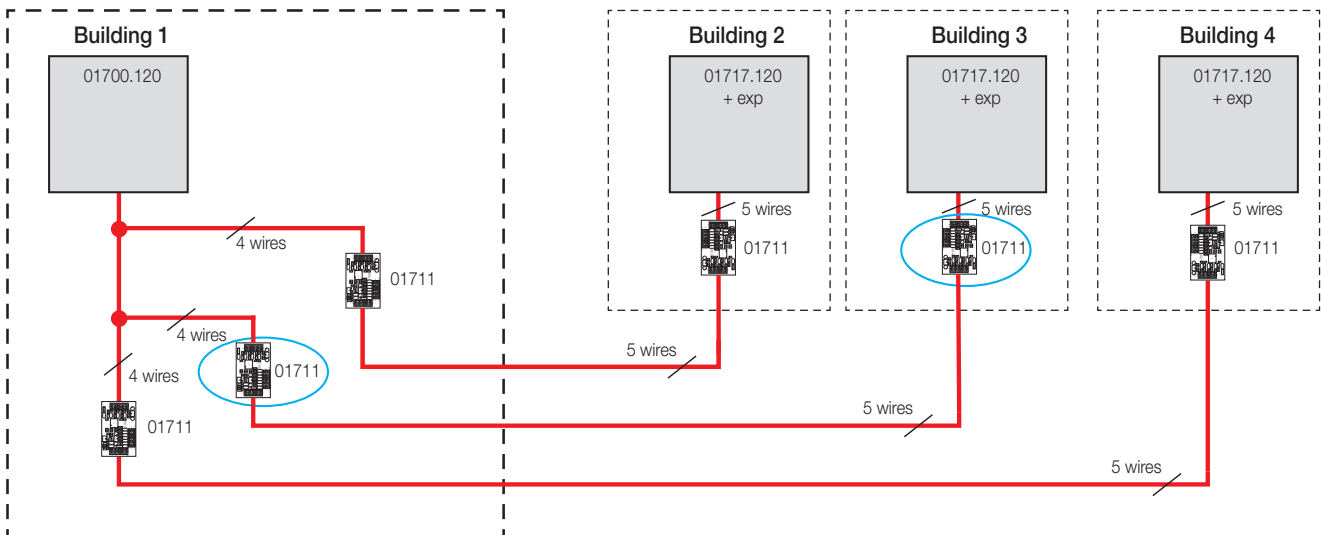
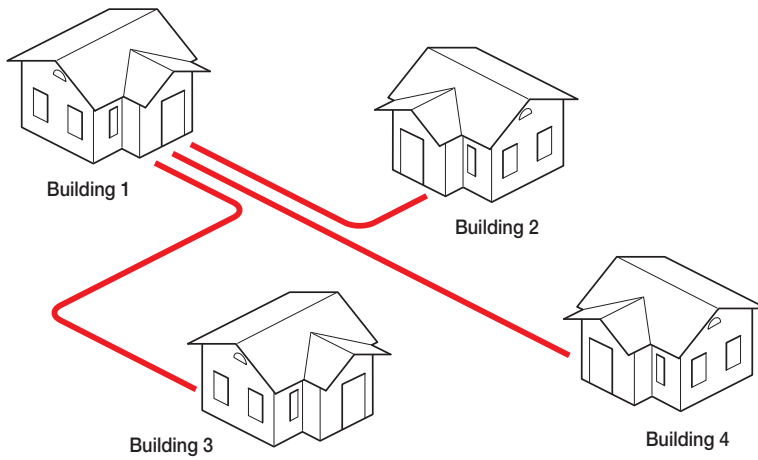

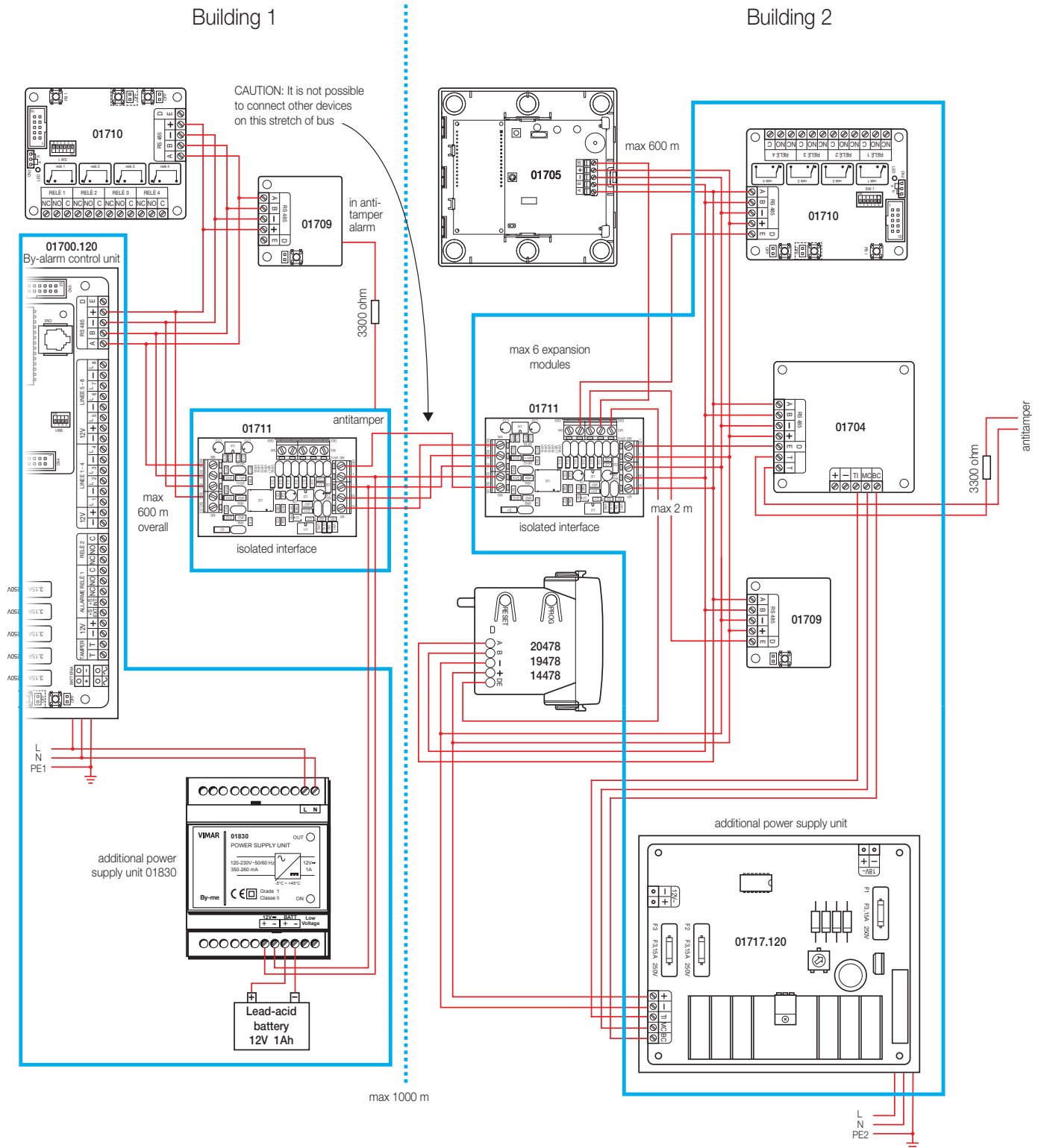

CAUTION: Do not connect the DE signals of the different devices together, but use the special terminal of the isolated interface 01711.

N.B. If there are no 8-input modules 01704, the tamper-proof signal with balancing resistance 3.3 kΩ must be carried to a 4-input expansion module 01709.



01700.120IEN-I 05 1805