

Installer manual

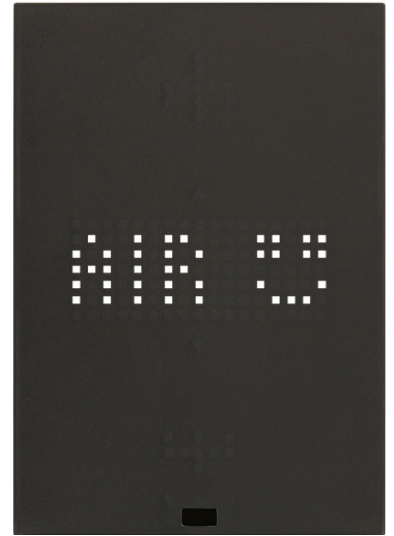

32142
KNX XT Multisensor

GENERAL CHARACTERISTICS AND FUNCTIONS from page 5

COMMUNICATION OBJECTS AND ETS PARAMETERS from page 9

For all the details about the Well-contact Plus system, refer to the installer manual that can be downloaded from the Software ➔ Product Software ➔ Well-contact Plus section of the website: www.vimar.com.

General characteristics and functions

Linea XT platform control device, KNX standard, thermostat function for ambient temperature control (heating and air-conditioning), 2- and 4-pipe system management, 3-speed and proportional fan coil control, class I temperature control device (contribution 1%) in ON/OFF mode, class IV (contribution 2%) in PID mode, can be interfaced with actuator with proportional analogue outputs to create a class V modulating room thermostat (contribution 3%), humidistat function with ON/OFF control with respect to a set parameter, VOC (volatile organic compound) function with ON/OFF control, proportional or to call up 2 scenarios, 2 push button function with configuration also as 1 rocker button with status identification LED, central LED matrix to customise symbols or animation, proximity function, white LED backlighting, black - 2 front modules.

The device is KNX Data Secure and is equipped with a dedicated QR code to be used with ETS (version 5.5 and later) during configuration.

General characteristics

The device is integrated with the following four sensors:

• Temperature sensor

The temperature sensor is integrated with the KNX home automation system and allows the current temperature to be shown on the display or the data to be sent to the bus. It can be used in the thermostat function to manage temperature control in 2 or 4 pipe systems (heating/conditioning) and neutral zone (4 pipe systems only), with "boost" function to run a second source to reach the desired thermal comfort quicker. The 4 available outputs (hot, cold, second stage hot, second stage cold) for the fans can be configured to control 3-speed fan coils, proportional fan coils or to control HVAC type split/VRV systems via third-party KNX interfaces (if the first stage controls split/VRV systems, the second cannot do so). The thermostat is fitted with a white LED matrix display and 2 keys to control the temperature setpoint and to turn the temperature control system on/off. Opposite each key are white LEDs for the "up and down arrow" or "+ and -" symbols. There are also two LEDs that indicate the heating valve control phase (amber or configurable white LED) or cooling phase (blue or configurable white LED). During the configuration phase, you can choose whether to view the room temperature, the current setpoint or the current setpoint delta normally. The thermostat can control proportional fan coils, 3-speed fan coils or HVAC type split/VRV systems via third-party KNX interfaces.

• Humidity sensor

The humidity sensor is integrated with the KNX home automation system and allows the current humidity to be shown on the display or the data to be sent to the bus. It also allows the humidistat function by sending an On/Off control on the bus when the humidity value increases or decreases with respect to a parameter set during the configuration phase. It can be used to manage ventilation and for dewpoint management, in combination with the temperature.

• VOC air quality control sensor

The VOC (volatile organic compounds) sensor is integrated with the KNX home automation system and allows the air quality variations to be shown on the display or the data to be sent to the bus. It also allows the sending of an On/Off control or to call up 2 scenarios when the air quality worsens or improves with respect to parameters set during the configuration phase. The VOC sensor, in combination with temperature and humidity, makes it possible to manage ventilation to improve the quality of the air.

• Proximity sensor

The proximity sensor (the sensitivity of which can be set from ETS) enables the multisensor activation by approaching a hand at a distance set during the configuration phase. Activation propagates the information to the other controls on the same electrified XT mounting frame. The time on standby is configurable. Proximity detection can be associated with the sending of a bit control or the calling up of a scenario.

The device can be used in the following ways:

- **Mode 1 - "Master thermostat"**: Locally controlled thermostat for ON/OFF + setpoint adjustment, possibly with interface block function (as per parameter) without symbols on the keys. The symbols of the upper and lower keys can be customised, choosing from a list on ETS. It allows:
 - Viewing of temperature and setpoint on central display. If the climate control art. 32144.x is present, values room T, Text (received on object 189), H and VOC will be shown on the display every time the key is pressed.
 - Editing of the values: summer_winter/fan speed/Celsius_Fahrenheit/on_off using the external keys of the climate control.
- **Mode 2 - "Slave thermostat"**: It only works as a remote user interface for the master thermostat and as a viewer for the internal sensors for internal temperature, humidity, and air quality. The slave thermostat can modify the setpoint set on the master thermostat by sending the new value to the bus. The average temperature calculated with related weighting and distributed by the master thermostat can be displayed on both the master thermostat and the slave thermostats. Temperature control is performed by the master thermostat based on the average temperature. For this function to work, the slave thermostats must send their detected temperature to the master thermostat, which then distributes the average temperature to be displayed and the setpoint.
- **Mode 3 - "Sensor viewer"**: Viewer of the values T, Text (received on object 189), H and VOC on the display. It is used as a simple viewer and normally shows the current temperature. Using the two keys on the device (or with climate control art. 32144.x) the values of the local temperature, remote probe temperature, humidity and air quality can be browsed and displayed.
- **Mode 4 - "Rocker switch/push button control"**: Control with 2 push buttons or 1 rocker switch where the 2 keys can be configured as 2 push buttons or grouped together as 1 rocker switch. The symbols of the upper and lower keys can be customised. In the case of 1 rocker switch the central white LED matrix can be used for customised symbols or for animation, while in the case of 2 push buttons it can be used to display any alarms, load status and scenario activation with customised symbols. The values T, H and VOC are not shown on the display but they are made available on the bus.
- **Mode 5 - "Push button control/rocker switch with thermostat function"**: Control with 2 push buttons or 1 rocker switch where the 2 keys can be configured as 2 push buttons or grouped together as 1 rocker switch + thermostat. The symbols of the upper and lower keys can be customised. In the case of 1 rocker switch the central white LED matrix can be used for customised symbols or for animation, while in the case of 2 push buttons it can be used to display any alarms, load status and scenario activation with customised symbols. The values T, H and VOC are not shown on the display but they are made available on the bus.
- **Mode 6 - "Room number"**: Allows you to view the room number from 0 to 9999. The lower push button can be programmed for "bell" function with message sending on the bus.

Functions available for each mode:

- Humidity/air quality/external temperature values made available on the bus.
- Sending of ON/OFF controls when the humidity value measured increases/decreases with respect to a threshold configured on ETS (sending of two controls in reference to two thresholds).
- Sending of ON/OFF control or activation of two scenarios when the air quality improves or worsens with respect to a threshold configured on the ETS App.
- Wake-up of device upon external events (e.g. change in contact interface status, PIR sensors).
- Sending of ON/OFF control or activation of a scenario upon proximity detection

General characteristics and functions

User Interface

The multisensor has 2 front buttons and a white LED display which have different functions as the "Main function" of the device changes.

The possible main functions are:

- Thermostat: master
- Thermostat: slave
- Viewing only
- Buttons
- Buttons + Thermostat (no displayT)
- Room number

Master thermostat and slave thermostat



Thermostat in standby

Thermostat active in ON mode

Thermostat active in OFF mode

The central white LED display normally displays what has been decided in the "Value shown on the display" parameter.

Briefly pressing the upper button increases the setpoint, whereas the lower button allows you to decrease the setpoint.

Long pressing the upper button allows you to turn on the thermostat in ON mode, whereas the lower button allows you to turn off the thermostat and set it to OFF status.

The amber and blue LEDs indicate whether the thermostat is activating the heating or cooling respectively. The amber and blue LEDs can be configured as white using the "Monochrome" parameter.

The display can also signal the following alarms (with higher priority for the "Boiler shutdown" and lower priority for the "Window alarm").

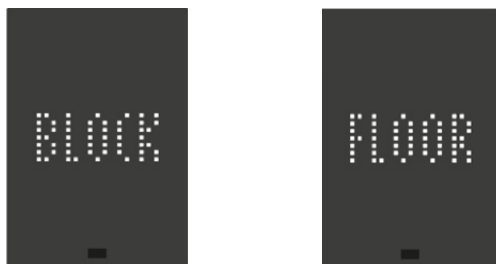

Boiler shutdown

Floor

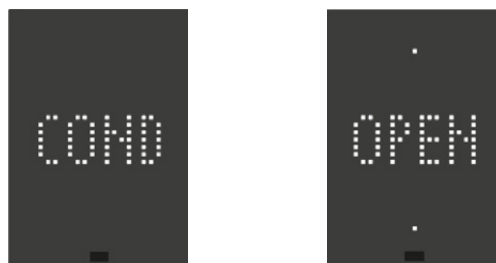

Condensation

Window

Viewing only



Internal temperature



Humidity



Air quality



External temperature

The central white LED display normally displays the internal temperature. Briefly pressing the upper and lower button allows you to scroll through the other values, where activated:

- Humidity
 - Read by the internal sensor or
 - Received on the object 198 if reception from bus was chosen during configuration
- Air quality:
 - Read by the internal sensor or
 - Received on the object 191 if reception from bus was chosen during configuration
- External temperature:
 - Received on the object 189

Buttons and Buttons + Thermostat (no displayT)

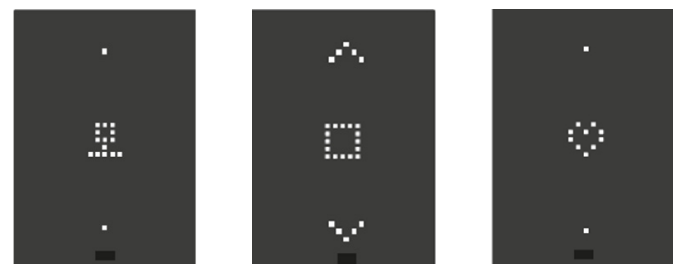

ON/OFF control or Dimmer

Roller shutter control

Call up scenario

The central white LED display shows the icon and the animation chosen during configuration.

Briefly pressing the buttons allows you to:

- turn loads on and off in the case of ON/OFF and Dimmer
- stop the roller shutters or turn the slats
- call up a scenario

Long pressing the buttons allows you to:

- increase and decrease the brightness of the loads in the case of Dimmers
- raise and lower the roller shutters in the case of roller shutters

General characteristics and functions

Room number



Room number

The central white LED display shows the room number chosen during configuration. As the lower button is pressed, an ON message is sent on the Bus, and as it is released, an OFF message is sent. The object concerned is number 189 and it can be used for the “bell” function.

The amber LED is associated with the status of object number 185 and it can be used for signalling (e.g. Do not disturb).

Master/slave function

The temperature measurements taken in multiple places can be managed to determine an average value to be used for temperature control/cooling.

The temperature control logic is performed by the thermostat configured as the master, whereas the thermostat configured as the slave works as a temperature probe, humidity sensor, air quality sensor and remote user interface for the master thermostat; the setpoint set in the master thermostat can be modified from a slave thermostat. The average temperature calculated with the relative weight is shown on all the displays of the slave thermostats and temperature control is performed based on the average temperature; for this function to work, the slave thermostats must send their detected temperature to the master thermostat, which then distributes the average temperature to be displayed and the setpoint.

Master thermostat

- Receives the temperature from the probes or from the slave thermostats on objects
 - no. 2 “External Temperature 1”
 -
 - no. 9 “External Temperature 8”and calculates the average with the weights of the various temperatures for the day or night
- Transmits to the slave thermostats the temperature calculated on object
 - no. 11 “Current temperature”
- Receives the setpoint from the slave thermostats on object
 - no. 49 “Current setpoint receipt”
- Transmits the current setpoint upon change to object
 - no. 30 “Current setpoint”. When operating in Neutral zone mode, it is necessary to select “Current setpoint” for the “Setpoint to send to neutral zone” parameter.

Slave thermostat

- Transmits its internal temperature to the master thermostat on object
 - no. 1 “Internal sensor”
- Receives the average temperature to be displayed on object
 - no. 11 “Average temperature”.
- Receives the current setpoint on object
 - no. 49 “Current setpoint receipt”
- By acting on the display of the slave thermostat, you can send the master thermostat the new setpoint on object
 - no. 30 “Current slave setpoint”
- Sends the air quality index and humidity on the dedicated objects

General characteristics and functions

Neutral zone

The "Neutral Zone" is an operating mode of the thermostat (only for 4-pipe systems) in which the device keeps the temperature within a temperature range preset by the Winter Setpoint and Summer Setpoint (basically, there is no longer the usual Summer/Winter mode). If the measured temperature is below the Winter Setpoint, the thermostat switches on the heating valve and heats the room until the temperature exceeds the set value (e.g. 20°C for Comfort mode or 18°C for Standby mode). If the measured temperature exceeds the Summer Setpoint then the thermostat switches on the cooling valve and keeps it on until the temperature falls below the set Summer Setpoint value. Within the Neutral Zone the thermostat does not switch on any valves and the temperature can vary freely; this zone is therefore nothing more than the difference between the Summer and Winter Setpoints when the room temperature is between the winter setpoint and the summer one.

To avoid excessive temperature fluctuations, set a limited range ($\leq 2^{\circ}\text{C}$) as shown in the figure below.

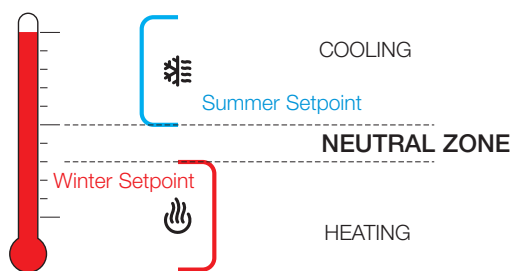

Setpoint in Neutral Zone operation

When the thermostat is working in the neutral zone, the setpoint used for the adjustment is always the **Current Setpoint**, namely the one relating to the last heating/cooling mode that came into operation; the value displayed is instead a new setpoint named "**Neutral Zone Setpoint**", which is the average value between the current summer and winter setpoints.

Changing the temperature of the "Neutral Zone Setpoint" (with the "+" and "-" buttons on the thermostat) will also cause a change to the value of the "Shift Setpoint" resulting in a shift of the two current summer/winter setpoint values; the room temperature will therefore not become the one set by the guest but that of the summer/winter setpoint which at that moment is closest to the value of the current temperature in the room. Between the two summer/winter setpoints, there is the neutral zone in which the system is not activated.

Using the "Setpoint to send in neutral zone" parameter, you can also configure the value to be sent on the bus:

- Current setpoint, in other words the one used for control, which is the one used by the last mode (heating or cooling) that came into operation;
- Average setpoint, in other words the value shown on the display as the average of the heating and cooling setpoints.

The value displayed always remains the average Setpoint, regardless of the choice made.

The parameter is only available if the neutral zone is enabled in the "Thermostat settings" menu.

Mid Season

This function is only available as a supervisor for systems configured with a primary and secondary output; when it is active, it swaps the 2 main and secondary outputs (the valve of the 2nd stage does not use its own threshold parameter but utilises the "Differential coefficient" parameter of the 1st stage). It is recommended for making minor adjustments (such as $\pm 2^{\circ}\text{C}$) during mid season periods where it may be more convenient to operate only the secondary circuit (for instance Split).

Configuration

The thermostat is configured in Neutral Zone mode if the "Neutral Zone" parameter has been set.

The thermostat can operate in Neutral Zone **IF**:

- The system has 4 pipes
- **Winter Comfort Setpoint** < **Summer Comfort Setpoint**
- **Winter Standby Setpoint** < **Summer Standby Setpoint**
- **Winter Economy Setpoint** < **Summer Economy Setpoint**
- **Antifreeze** < **Too Hot**

If these conditions are not satisfied, you can still commission the thermostat; if there is an error while starting up, the device will remain in active mode and an error message will be displayed.

Types of errors at the time of configuration

Error No.	Description
E82	Winter Comfort Setpoint \geq Summer Comfort Setpoint
E83	Winter Standby Setpoint \geq Summer Standby Setpoint
E84	Winter Economy Setpoint \geq Summer Economy Setpoint
E85	Antifreeze \geq Too Hot
E86	Selected 2-pipe system instead of 4-pipe system
E87	Selected Cooling only or Heating only function in a 4-pipe system
E88	Selected 6-way valve with neutral zone disabled

Communication objects and ETS parameters

List of existing communication objects and standard settings

No.	ETS name	Function	Description	Type	Flag 1						Priority
					C	R	W	T	U	I	
1	Internal sensor	Temperature	To see the temperature read by the sensor on board the thermostat itself	2 byte	C	R	-	T	-	-	Low
2	External temperature 1	Temperature	To receive the temperature read by a KNX probe connected to the bus	2 byte	C	-	W	-	U	-	Low
3	External temperature 2	Temperature	To receive the temperature read by a KNX probe connected to the bus	2 byte	C	-	W	-	U	-	Low
4	External temperature 3	Temperature	To receive the temperature read by a KNX probe connected to the bus	2 byte	C	-	W	-	U	-	Low
5	External temperature 4	Temperature	To receive the temperature read by a KNX probe connected to the bus	2 byte	C	-	W	-	U	-	Low
6	External temperature 5	Temperature	To receive the temperature read by a KNX probe connected to the bus	2 byte	C	-	W	-	U	-	Low
7	External temperature 6	Temperature	To receive the temperature read by a KNX probe connected to the bus	2 byte	C	-	W	-	U	-	Low
8	External temperature 7	Temperature	To receive the temperature read by a KNX probe connected to the bus	2 byte	C	-	W	-	U	-	Low
9	External temperature 8	Temperature	To receive the temperature read by a KNX probe connected to the bus	2 byte	C	-	W	-	U	-	Low
10	Average temperature	Temperature	To receive the average temperature calculated by the "Master" thermostat on the "Slave" thermostat.	2 byte	C	-	W	-	U	-	Low
11	Current temperature	Temperature	To see the current temperature associated with the thermostat (weighted average of the various associated probes): this object is used with the supervision software to see the temperature detected by the thermostat or to transmit it to the "Slave" thermostat	2 byte	C	R	-	T	-	-	Low
12	ON/OFF	ON/OFF mode	To turn the thermostat on and off by setting it to the ON or OFF statuses chosen in the ON Mode (default) and OFF Mode (default) parameters	1 bit	C	-	W	-	U	-	Low
13	Transmission ON/OFF	ON/OFF mode	To transmit the information whether the thermostat is in ON Mode or in OFF Mode. Sent upon change.	1 bit	C	R	-	T	-	-	Low
THERMOSTAT											
14	Comfort	Mode	To select COMFORT operating mode by sending a 1 bit or to set the thermostat to standby by sending a 0 bit	1 bit	C	-	W	-	U	-	Low
15	Comfort	Mode status	To transmit the status of the Comfort mode upon change	1 bit	C	R	-	T	-	-	Low
16	Standby	Mode	To select STANDBY operating mode by sending a 1 bit (a 0 bit is ignored)	1 bit	C	-	W	-	U	-	Low
17	Standby	Mode status	To transmit the status of the Standby mode upon change	1 bit	C	R	-	T	-	-	Low
18	Energy saving	Mode	To select ECONOMY operating mode by sending a 1 bit (a 0 bit is ignored)	1 bit	C	-	W	-	U	-	Low
19	Energy saving	Mode status	To transmit the status of the ECONOMY mode upon change	1 bit	C	R	-	T	-	-	Low
20	Protected	Mode	To select OFF-ANTIFREEZE operating mode (or Too Hot in the case of air conditioning) by sending a 1 bit.	1 bit	C	-	W	-	U	-	Low
21	Protected	Mode status	To transmit the status of the PROTECT mode upon change	1 bit	C	R	-	T	-	-	Low
22	Thermostat mode	Mode	To select the operating mode by sending a byte (1 = Comfort, 2 = StandBy, 3 = Economy, 4 = Protection). If a supervisor is used, this object must be associated with a group.	1 byte	C	-	W	-	U	-	Low
23	Thermostat mode	Mode status	To transmit or read the set operating mode by sending a byte (1 = Comfort, 2 = StandBy, 3 = Economy, 4 = Protection). If a supervisor is used, this object must be associated with a group.	1 byte	C	R	-	T	-	-	Low

Continued

C = Communication; R = Read; W = Write; T = Transmission; U = Enable update

Communication objects and ETS parameters

Continued

No.	ETS name	Function	Description	Type	Flag 1						Priority
					C	R	W	T	U	I	
24	Mid season	Mode	To transmit or read the information if mid season is active. Object available if the "Mid season management" parameter is active. 0 = MS Not active, 1 = MS Active)	1 bit	C	R	-	T	-	-	Low
25	Mid season	Mode status	To set the mid season function. Object available if the "Mid season management" parameter is active. (0 = MS Not active, 1 = MS Active)	1 bit	C	-	W	-	U	-	Low
26	Status	Summer/Winter	To transmit or read the seasonal mode set on the thermostat (0 = Summer, 1 = Winter)	1 bit	C	R	-	T	-	-	Low
27	Enable	Summer/Winter	To set the seasonal mode on the thermostat (1 = Winter, 0 = Summer)	1 bit	C	-	W	-	U	-	Low
28	Thermostat Off	Thermostat	This function is useful in the event of faults on the heating system to disable the valves and the fans with a 1 bit without modifying the operating mode	1 bit	C	-	W	-	U	-	Low
29	Mode trigger	Mode	To switch from one operating mode to the next upon receipt of either a 0 or a 1 bit (Comfort --> Standby --> Economy --> Protection). Upon first receipt of the message, the thermostat shows the current mode, the various modes scrolling upon subsequent receipts.	1 bit	C	-	W	-	U	-	Low
30	Current setpoint	Setpoint	To transmit or read the temperature setpoint set on the thermostat. If you want a supervisor to know the setpoint currently set on the thermostats, this object must be linked to a group	2 byte	C	R	-	T	-	-	Low
31	Shift setpoint	Setpoint	To read and control a temperature shift with respect to the current setpoint (when the thermostat is in an ON mode, i.e. Comfort or Standby). The temperature shift permitted is limited to the range set by the parameter: Guest Control Permitted . If parameter Guest Control Permitted is set to Off the "Setpoint Shift" object does not change the active setpoint.	2 byte	C	R	W	T	-	-	Low
32	Winter Comfort	Setpoint	To read and set the Winter Comfort setpoint.	2 byte	C	R	W	T	U	-	Low
33	Winter standby	Setpoint	To read and set the Winter Standby setpoint	2 byte	C	R	W	T	U	-	Low
34	Winter energy saving	Setpoint	To read and set the Winter Economy setpoint	2 byte	C	R	W	T	U	-	Low
35	Winter protection	Setpoint	To read and set the Winter Antifreeze setpoint	2 byte	C	R	W	T	U	-	Low
36	Summer Comfort	Setpoint	To read and set the Summer Comfort setpoint	2 byte	C	R	W	T	U	-	Low
37	Summer standby	Setpoint	To read and set the Summer Standby setpoint	2 byte	C	R	W	T	U	-	Low
38	Summer energy saving	Setpoint	To read and set the Summer Economy setpoint	2 byte	C	R	W	T	U	-	Low
39	Summer protection	Setpoint	To read and set the Summer Too Hot setpoint	2 byte	C	R	W	T	U	-	Low
40	Setpoint shift increase	Setpoint	Increases the setpoint shift upon receipt of either a 1 or a 0 (when the thermostat is in an ON mode, therefore Comfort or Standby). The shift is decided in the Setpoint shift step parameter. The temperature shift permitted is limited to the range set by the parameter: Guest Control Permitted . If parameter Guest Control Permitted is set to Off the "Setpoint Shift" object does not change the active setpoint.	1 bit	C	-	W	-	U	-	Low
41	Setpoint shift decrease	Setpoint	Decreases the setpoint shift upon receipt of either a 1 or a 0 (when the thermostat is in an ON mode, therefore Comfort or Standby). The shift is decided in the Setpoint shift step parameter. The temperature shift permitted is limited to the range set by the parameter: Guest Control Permitted . If parameter Guest Control Permitted is set to Off the "Setpoint Shift" object does not change the active setpoint.	1 bit	C	-	W	-	U	-	Low
42	Window sensor	Window	Object to be paired with the input to which a window-contact is connected so that the thermostat switches to OFF-PROTECTED when the window is opened, depending on whether the mode is Air Conditioning or Heating	1 bit	C	-	W	-	U	-	Low

Continued

C = Communication; R = Read; W = Write; T = Transmission; U = Enable update

Communication objects and ETS parameters

Continued

No.	ETS name	Function	Description	Type	Flag 1						Priority
					C	R	W	T	U	I	
43	Boiler shutdown	Alarm	To receive information about the boiler having shut down. In this case, the thermostat is set to OFF-PROTECTED mode and stays that way even when the alarm condition is resolved. The user intervention is required to change the mode.	1 bit	C	-	W	-	U	-	Low
44	Scenario	Scenario	To activate a scenario with a 1 byte message	1 byte	C	-	W	-	U	-	Low
45	Temperature: Automatic/Manual	Manual operation	To see whether the guest has altered the thermostat temperature setpoint with respect to the default setting	1 bit	C	R	-	T	-	-	Low
46	Floor temperature	Alarm	If the temperature limitation is active an alarm is sent when the temperature exceeds the set threshold. In the event of an alarm, the thermostat is set to OFF-PROTECTED mode and stays that way even when the alarm condition is resolved. The user intervention is required to change the mode.	1 bit	C	R	-	T	-	-	Low
47	NOT USED										
48	ON/OFF Trigger	ON/OFF	To switch from the ON operating mode to the OFF operating mode upon receipt of either a 0 or a 1 bit. Upon first receipt of the message, the thermostat shows the current status, scrolling from one status to the next upon subsequent receipts.	1 bit	C	-	W	-	U	-	Low
49	Current setpoint receipt	Setpoint	To set the setpoint (in the master thermostat) as supervisor or slave thermostat. To receive (in the slave thermostat) the information about the setpoint currently used by the master thermostat for the temperature control logic. The device accepts any value between -15°C and +45°C ignoring the limit to the range set by the Guest control permitted parameter. The change is permitted both when it is in an ON mode as well as when it is in an OFF mode.	1 byte	C	-	W	-	U	-	Low
Valves											
50	Cooling/heating valve	Valve	If the "Valve" parameter is set for 2-pipe systems for valve management: to be used to control the head of a radiating system or the On/Off valve of a fan coil	1 bit	C	R	-	T	-	-	Low
50	Cooling/heating valve	Valve	If the Valve parameter is set for 2-pipe systems and the Valve type is Proportional	1 byte	C	R	-	T	-	-	Low
50	Heating valve	Valve	If the Valve parameter is set for 4-pipe systems and the Valve type is Heating On/Off	1 bit	C	R	-	T	-	-	Low
50	Heating valve	Valve	If the Valve parameter is set for 4-pipe systems and the Valve type is Proportional Heating	1 byte	C	R	-	T	-	-	Low
50	6-way valve	Valve	If the 6-way Valve parameter is set	1 byte	C	R	-	T	-	-	Low
51	Heating valve	2 nd heating stage	If the 2 nd Stage Heating Valve parameter is set to Enable 2-point On/Off control.	1 bit	C	R	-	T	-	-	Low
51	Heating valve	2 nd heating stage	If the 2 nd Stage Heating Valve parameter is set to Enable 2-point 0-100%control.	1 byte	C	R	-	T	-	-	Low
52	NOT USED										
55	NOT USED										
53	Cooling valve	Valve	If the Valve parameter is set for 4-pipe systems and the Valve type is Cooling On/Off.	1 bit	C	R	-	T	-	-	Low
53	Cooling valve	Valve	If the Valve parameter is set for 4-pipe systems and the Valve type is Proportional Cooling.	1 byte	C	R	-	T	-	-	Low
54	Cooling valve	2 nd cooling stage	If the 2 nd Stage Cooling Valve parameter is set to Enable 2-point On/Off control.	1 byte	C	R	-	T	-	-	Low
54	Cooling valve	2 nd cooling stage	If the 2 nd Stage Cooling Valve parameter is set to Enable 2-point 0-100%control.	1 byte	C	R	-	T	-	-	Low
55	NOT USED										

Continued

C = Communication; R = Read; W = Write; T = Transmission; U = Enable update

Communication objects and ETS parameters

Continued

No.	ETS name	Function	Description	Type	Flag 1						Priority
					C	R	W	T	U	I	
Heating valve											
56	Proportional (0- 100%)	Heating Fan inputs	Used to set a proportional speed for the fan coil fan (if the selected fan is proportional or with 3 speeds with proportional 8-bit output) via a supervisor (e.g., touch screen)	1 byte	C	-	W	-	U	-	Low
56	Proportional	Split/VRV heating fan	Used to receive the proportional speed value to set on the split/VRV interface fan or to receive feedback from the split/VRV interface (if the fan is set for split/VRV management with proportional fan management).	1 byte	C	-	W	-	U	-	Low
57	Proportional (0- 100%)	Heating Fan outputs	Used to send a proportional speed for the fan coil fan (if the selected fan is proportional or with 3 speeds with proportional 8-bit output).	1 byte	C	R	-	T	-	-	Low
57	Proportional	Split/VRV heating fan	Used to send the proportional speed value to set on the split/VRV interface fan (if the fan is set for split/VRV management with proportional fan management).	1 byte	C	R	-	T	-	-	Low
58	Speed 1	Heating Fan inputs	Used to force activation of fan coil speed V1 (if the selected fan has 3 speeds)	1 bit	C	-	W	-	U	-	Low
58	Speed 1	Split/VRV heating fan inputs	Used to force the speed 1 to send to the split/VRV interface or to receive operating feedback about the fan 1 (if the fan is set for split/VRV management with bits management of the fans).	1 bit	C	-	W	-	U	-	Low
59	Speed 2	Heating Fan inputs	Used to force activation of fan coil speed V2 (if the selected fan has 3 speeds)	1 bit	C	-	W	-	U	-	Low
59	Speed 2	Split/VRV heating fan inputs	Used to force the speed 2 to send to the split/VRV interface or to receive operating feedback about the fan 2 (if the fan is set for split/VRV management with bits management of the fans).	1 bit	C	-	W	-	U	-	Low
60	Speed 3	Heating Fan inputs	Used to force activation of fan coil speed V3 (if the selected fan has 3 speeds)	1 bit	C	-	W	-	U	-	Low
60	Speed 3	Split/VRV heating fan inputs	Used to force the speed 3 to send to the split/VRV interface or to receive operating feedback about the fan 3 (if the fan is set for split/VRV management with bits management of the fans with a speed value of 3 or more).	1 bit	C	-	W	-	U	-	Low
61	Speed 4	Split/VRV heating fan inputs	Used to force the speed 4 to send to the split/VRV interface or to receive operating feedback about the fan 4 (if the fan is set for split/VRV management with bits management of the fans with a speed value of 4 or more).	1 bit	C	-	W	-	U	-	Low
62	Speed 5	Split/VRV heating fan inputs	Used to force the speed 5 to send to the split/VRV interface or to receive operating feedback about the fan 5 (if the fan is set for split/VRV management with bits management of the fans with a speed value of 5).	1 bit	C	-	W	-	U	-	Low
63	Speed Off	Heating Fan outputs	Used to read the deactivation status of all 3 speeds (if the selected fan has 3 speeds with bit output or for split/VRV management with bits management of the fans). The thermostat sends a 1 bit when the fan is off (fan coil speed 0).	1 bit	C	R	-	T	-	-	Low
64	Speed 1	Heating Fan outputs	This is the object to pair with the relay of speed 1 of the fan coil (in addition to controlling speed V1, it allows you to read the status of speed V1 of the fan coil)	1 bit	C	R	-	T	-	-	Low
64	Speed 1	Split/VRV heating fan outputs	To control or read the status of speed 1 of the split/VRV interface (if the fan is set for split/VRV management with bits management of the fans).	1 bit	C	R	-	T	-	-	Low
65	Speed 2	Heating Fan outputs	This is the object to pair with the relay of speed 2 of the fan coil (in addition to controlling speed V2, it allows you to read the status of speed V2 of the fan coil)	1 bit	C	R	-	T	-	-	Low
65	Speed 2	Split/VRV heating fan outputs	To control or read the status of speed 2 of the split/VRV interface (if the fan is set for split/VRV management with bits management of the fans).	1 bit	C	R	-	T	-	-	Low

Continued

C = Communication; R = Read; W = Write; T = Transmission; U = Enable update

Communication objects and ETS parameters

Continued

No.	ETS name	Function	Description	Type	Flag 1						Priority
					C	R	W	T	U	I	
66	Speed 3	Heating Fan outputs	This is the object to pair with the relay of speed 3 of the fan coil (in addition to controlling speed V3, it allows you to read the status of speed V3 of the fan coil)	1 bit	C	R	-	T	-	-	Low
66	Speed 3	Split/VRV heating fan outputs	To control or read the status of speed 3 of the split/VRV interface (if the fan is set for split/VRV management with bits management of the fans and speed value of 3 or more).	1 bit	C	R	-	T	-	-	Low
67	Speed 4	Split/VRV heating fan outputs	To control or read the status of speed 4 of the split/VRV interface (if the fan is set for split/VRV management with bits management of the fans and speed value of 4 or more).	1 bit	C	R	-	T	-	-	Low
68	Speed 5	Split/VRV heating fan outputs	To control or read the status of speed 5 of the split/VRV interface (if the fan is set for split/VRV management with bits management of the fans and speed value of 5 or more).	1 bit	C	R	-	T	-	-	Low
69	Enum speed	Split/VRV heating fan inputs	Used to force - via a value chosen in the parameters - a speed to send to the split/VRV interface or to receive operating feedback about a fan (if the fan is set for split/VRV management with enum management of the fans).	1 bit	C	-	W	-	U	-	Low
70	Enum speed info	Split/VRV heating fan outputs	To control or read the status of the speeds of the split/VRV interface (if the fan is set for split/VRV management with enum management of the fans).	1 bit	C	R	-	T	-	-	Low
71	Generic fan speed	Split/VRV heating fan outputs	To control the split/VRV interface via a proportional object type 5.001 (if the fan is set for split/VRV management with proportional fan management).	1 byte	C	R	-	T	-	-	Low
72	Speed 1	Disable Heating fan	To disable speed V1 (if the selected fan has 3 speeds)	1 bit	C	R	W	T	U	-	Low
73	Speed 2	Disable Heating fan	To disable speed V2 (if the selected fan has 3 speeds)	1 bit	C	R	W	T	U	-	Low
74	Speed 3	Disable Heating fan	To disable speed V3 (if the selected fan has 3 speeds)	1 bit	C	R	W	T	U	-	Low
75	Split/VRV ON/OFF	Split/VRV heating ON/OFF	To turn the split/VRV interface on and off if the temperature control logic is performed by the thermostat, enabling the Split/VRV parameter controlled by the thermostat (if the fan is set for split/VRV management).	1 bit	C	R	-	T	-	-	Low
76	Split/VRV Info ON/OFF	Split/VRV heating ON/OFF	Used to force the split/VRV interface switch-ON or to receive ON/OFF feedback (if the fan is set for split/VRV management).	1 bit	C	-	W	-	U	-	Low
77	Fan coil: Automatic/Manual	Manual Heating operation	Used to set the operation of the fans in manual or automatic.	1 bit	C	-	W	-	U	-	Low
78	Fan coil: Automatic/Manual	Manual Heating operation	To see whether the guest has altered the fan speed with respect to the default setting	1 bit	C	R	-	T	-	-	Low
79	Fan trigger	Heating Fan inputs	To switch from one speed to the next upon receipt of either a 0 or a 1 bit. Upon first receipt of the message, the thermostat shows the current speed, scrolling through the list of possible speeds upon subsequent receipts.	1 bit	C	-	W	-	U	-	Low
79	Fan trigger	Split/VRV heating fan trigger	Used to receive the fan speed increase control to send to the split/VRV interface. Upon first receipt of the message, the thermostat shows the current speed, scrolling through the list of possible speeds upon subsequent receipts.	1 bit	C	-	W	-	U	-	Low
80	Speed step	Split/VRV heating fan inputs	To increase or decrease the speed of the fans in the case of split/VRV system management	1 bit	C	-	W	-	U	-	Low
81	Mode trigger	Split/VRV heating mode	To move on to the next mode upon receipt of either a 0 bit or a 1 bit for the management of split/VRV systems (the available modes are decided during configuration). Upon first receipt of the message, the thermostat shows the current mode, scrolling through the list of possible modes upon subsequent receipts.	1 bit	C	-	W	-	U	-	Low
82	Fan coil: Automatic/Manual	Split/VRV heating manual operation	Used to set the operation of the fans in manual or automatic (if the fan is set for split/VRV management).	1 bit	C	-	W	-	U	-	Low
83	Fan coil: Automatic/Manual	Split/VRV heating manual operation	Used to send the split/VRV interface the automatic or manual operation control of the VRV interface.	1 bit	C	R	-	T	-	-	Low

Continued

C = Communication; R = Read; W = Write; T = Transmission; U = Enable update

Communication objects and ETS parameters

Continued

No.	ETS name	Function	Description	Type	Flag 1						Priority
					C	R	W	T	U	I	
84	Step mode	Split/VRV heating mode	To move on to the next mode or the previous mode in the management of split/VRV systems (the available modes are decided during configuration if the control logic is performed by the thermostat. If the logic is handled by the split/VRV system, the available modes are AUTO=0, HEAT=1, COOL=3, FAN=9, DRY=14).	1 bit	C	-	W	-	U	-	Low
85	Mode	Split/VRV heating mode	To force an operating mode in the management of split/VRV systems (the available modes are decided during configuration if the control logic is performed by the thermostat. If the logic is handled by the split/VRV system, the available modes are AUTO=0, HEAT=1, COOL=3, FAN=9, DRY=14).	1 byte	C	-	W	-	U	-	Low
86	Mode info	Split/VRV heating mode	To control or read an operating mode in the management of split/VRV systems (the available modes are decided during configuration if the control logic is performed by the thermostat. If the logic is handled by the split/VRV system, the available modes are AUTO=0, HEAT=1, COOL=3, FAN=9, DRY=14).	1 byte	C	-	W	-	U	-	Low
Cooling fan											
87	Proportional (0- 100%)	Cooling Fan inputs	Used to set a proportional speed for the fan coil fan (if the selected fan is proportional or with 3 speeds with proportional 8-bit output) via a supervisor (e.g., touch screen)	1 byte	C	-	W	-	U	-	Low
87	Proportional	Split/VRV heating fan	Used to receive the proportional speed value to set on the split/VRV interface fan or to receive feedback from the split/VRV interface (if the fan is set for split/VRV management with proportional fan management).	1 byte	C	-	W	-	U	-	Low
88	Proportional (0- 100%)	Cooling Fan outputs	Used to send a proportional speed for the fan coil fan (if the selected fan is proportional or with 3 speeds with proportional 8-bit output).	1 byte	C	R	-	T	-	-	Low
88	Proportional	Split/VRV Cooling fan	Used to send the proportional speed value to set on the split/VRV interface fan (if the fan is set for split/VRV management with proportional fan management).	1 byte	C	R	-	T	-	-	Low
89	Speed 1	Cooling Fan inputs	Used to force activation of fan coil speed V1 (if the selected fan has 3 speeds)	1 bit	C	-	W	-	U	-	Low
89	Speed 1	Split/VRV Cooling fan inputs	Used to force the speed 1 to send to the split/VRV interface or to receive operating feedback about the fan 1 (if the fan is set for split/VRV management with bits management of the fans).	1 bit	C	-	W	-	U	-	Low
90	Speed 2	Cooling Fan inputs	Used to force activation of fan coil speed V2 (if the selected fan has 3 speeds)	1 bit	C	-	W	-	U	-	Low
90	Speed 2	Split/VRV Cooling fan inputs	Used to force the speed 2 to send to the split/VRV interface or to receive operating feedback about the fan 2 (if the fan is set for split/VRV management with bits management of the fans).	1 bit	C	-	W	-	U	-	Low
91	Speed 3	Cooling Fan inputs	Used to force activation of fan coil speed V3 (if the selected fan has 3 speeds)	1 bit	C	-	W	-	U	-	Low
91	Speed 3	Split/VRV Cooling fan inputs	Used to force the speed 3 to send to the split/VRV interface or to receive operating feedback about the fan 3 (if the fan is set for split/VRV management with bits management of the fans with a speed value of 3 or more).	1 bit	C	-	W	-	U	-	Low
92	Speed 4	Split/VRV Cooling fan inputs	Used to force the speed 4 to send to the split/VRV interface or to receive operating feedback about the fan 4 (if the fan is set for split/VRV management with bits management of the fans with a speed value of 4 or more).	1 bit	C	-	W	-	U	-	Low
93	Speed 5	Split/VRV Cooling fan inputs	Used to force the speed 5 to send to the split/VRV interface or to receive operating feedback about the fan 5 (if the fan is set for split/VRV management with bits management of the fans with a speed value of 5).	1 bit	C	-	W	-	U	-	Low

Continued

C = Communication; R = Read; W = Write; T = Transmission; U = Enable update

Communication objects and ETS parameters

Continued

No.	ETS name	Function	Description	Type	Flag 1						Priority
					C	R	W	T	U	I	
94	Speed Off	Cooling Fan outputs	Used to read the deactivation status of all 3 speeds (if the selected fan has 3 speeds with bit output or for split/VRV management with bits management of the fans). The thermostat sends a 1 bit when the fan is off (fan coil speed 0).	1 bit	C	R	-	T	-	-	Low
95	Speed 1	Cooling Fan outputs	This is the object to pair with the relay of speed 1 of the fan coil (in addition to controlling speed V1, it allows you to read the status of speed V1 of the fan coil)	1 bit	C	R	-	T	-	-	Low
95	Speed 1	Split/VRV Cooling fan Outputs	To control or read the status of speed 1 of the split/VRV interface (if the fan is set for split/VRV management with bits management of the fans).	1 bit	C	R	-	T	-	-	Low
96	Speed 2	Cooling Fan outputs	This is the object to pair with the relay of speed 2 of the fan coil (in addition to controlling speed V2, it allows you to read the status of speed V2 of the fan coil)	1 bit	C	R	-	T	-	-	Low
96	Speed 2	Split/VRV Cooling fan Outputs	To control or read the status of speed 2 of the split/VRV interface (if the fan is set for split/VRV management with bits management of the fans).	1 bit	C	R	-	T	-	-	Low
97	Speed 3	Cooling Fan outputs	This is the object to pair with the relay of speed 3 of the fan coil (in addition to controlling speed V3, it allows you to read the status of speed V3 of the fan coil)	1 bit	C	R	-	T	-	-	Low
97	Speed 3	Split/VRV Cooling fan Outputs	To control or read the status of speed 3 of the split/VRV interface (if the fan is set for split/VRV management with bits management of the fans and speed value of 3 or more).	1 bit	C	R	-	T	-	-	Low
98	Speed 4	Split/VRV Cooling fan Outputs	To control or read the status of speed 4 of the split/VRV interface (if the fan is set for split/VRV management with bits management of the fans and speed value of 4 or more).	1 bit	C	R	-	T	-	-	Low
99	Speed 5	Split/VRV Cooling fan Outputs	To control or read the status of speed 5 of the split/VRV interface (if the fan is set for split/VRV management with bits management of the fans and speed value of 5 or more).	1 bit	C	R	-	T	-	-	Low
100	Enum speed	Split/VRV Cooling fan inputs	Used to force - via a value chosen in the parameters - a speed to send to the split/VRV interface or to receive operating feedback about a fan (if the fan is set for split/VRV management with enum management of the fans).	1 bit	C	-	W	-	U	-	Low
101	Enum speed info	Split/VRV Cooling fan Outputs	To control or read the status of the speeds of the split/VRV interface (if the fan is set for split/VRV management with enum management of the fans).	1 bit	C	R	-	T	-	-	Low
102	Generic fan speed	Split/VRV Cooling fan Outputs	To control the split/VRV interface via a proportional object type 5.001 (if the fan is set for split/VRV management with proportional fan management).	1 bit	C	R	-	T	-	-	Low
103	Speed 1	Disable Cooling Fan	To disable speed V1 (if the selected fan has 3 speeds)	1 bit	C	R	W	T	U	-	Low
104	Speed 2	Disable Cooling Fan	To disable speed V2 (if the selected fan has 3 speeds)	1 bit	C	R	W	T	U	-	Low
105	Speed 3	Disable Cooling Fan	To disable speed V3 (if the selected fan has 3 speeds)	1 bit	C	R	W	T	U	-	Low
106	Split/VRV ON/OFF	Split/VRV Cooling ON/OFF	To turn the split/VRV interface on and off if the temperature control logic is performed by the thermostat, enabling the Split/VRV parameter controlled by the thermostat (if the fan is set for split/VRV management).	1 bit	C	R	-	T	-	-	Low
107	Split/VRV Info ON/OFF	Split/VRV Cooling ON/OFF	Used to force the split/VRV interface switch-ON or to receive ON/OFF feedback (if the fan is set for split/VRV management).	1 bit	C	-	W	-	U	-	Low
108	Fan coil: Automatic/Manual	Manual Heating operation	Used to set the operation of the fans in manual or automatic.	1 bit	C	-	W	-	U	-	Low
109	Fan coil: Automatic/Manual	Manual Cooling operation	To see whether the guest has altered the fan speed with respect to the default setting	1 bit	C	R	-	T	-	-	Low
110	Fan trigger	Cooling fan inputs	To switch from one speed to the next upon receipt of either a 0 or a 1 bit. Upon first receipt of the message, the thermostat shows the current speed, scrolling through the list of possible speeds upon subsequent receipts.	1 bit	C	-	W	-	U	-	Low

Continued

C = Communication; R = Read; W = Write; T = Transmission; U = Enable update

Communication objects and ETS parameters

Continued

No.	ETS name	Function	Description	Type	Flag 1						Priority
					C	R	W	T	U	I	
110	Fan trigger	Split/VRV Cooling fan Trigger	Used to receive the fan speed increase control to send to the split/VRV interface. Upon first receipt of the message, the thermostat shows the current speed, scrolling through the list of possible speeds upon subsequent receipts.	1 bit	C	-	W	-	U	-	Low
111	Speed step	Cooling fan inputs	To increase or decrease the speed of the fans in the case of split/VRV system management	1 bit	C	-	W	-	U	-	Low
112	Mode trigger	Split/VRV Cooling Mode	To move on to the next mode upon receipt of either a 0 bit or a 1 bit for the management of split/VRV systems (the available modes are decided during configuration). Upon first receipt of the message, the thermostat shows the current mode, scrolling through the list of possible modes upon subsequent receipts.	1 bit	C	-	W	-	U	-	Low
113	Fan coil: Automatic/ Manual	Split/VRV Cooling manual operation	Used to set the operation of the fans in manual or automatic (if the fan is set for split/VRV management).	1 bit	C	-	W	-	U	-	Low
114	Fan coil: Automatic/ Manual	Split/VRV heating manual operation	Used to send the split/VRV interface the automatic or manual operation control of the VRV interface.	1 bit	C	R	-	T	-	-	Low
115	Step mode	Split/VRV Cooling Mode	To move on to the next mode or the previous mode in the management of split/VRV systems (the available modes are decided during configuration if the control logic is performed by the thermostat. If the logic is handled by the split/VRV system, the available modes are AUTO=0, HEAT=1, COOL=3, FAN=9, DRY=14).	1 bit	C	-	W	-	U	-	Low
116	Mode	Split/VRV Cooling Mode	To force an operating mode in the management of split/VRV systems (the available modes are decided during configuration if the control logic is performed by the thermostat. If the logic is handled by the split/VRV system, the available modes are AUTO=0, HEAT=1, COOL=3, FAN=9, DRY=14).	1 byte	C	-	W	-	U	-	Low
117	Mode info	Split/VRV Cooling Mode	To control or read an operating mode in the management of split/VRV systems (the available modes are decided during configuration if the control logic is performed by the thermostat. If the logic is handled by the split/VRV system, the available modes are AUTO=0, HEAT=1, COOL=3, FAN=9, DRY=14)	1 byte	C	-	W	-	U	-	Low
2nd Stage Heating Fan											
118	Proportional (0- 100%)	2 nd Stage Heating Fan inputs	Used to set a proportional speed for the fan coil fan (if the selected fan is proportional or with 3 speeds with proportional 8-bit output) via a supervisor (e.g., touch screen)	1 byte	C	-	W	-	U	-	Low
118	Proportional	Split/VRV heating fan	Used to receive the proportional speed value to set on the split/VRV interface fan or to receive feedback from the split/VRV interface (if the fan is set for split/VRV management with proportional fan management).	1 byte	C	-	W	-	U	-	Low
119	Proportional (0- 100%)	2 nd Stage Heating Fan outputs	Used to send a proportional speed for the fan coil fan (if the selected fan is proportional or with 3 speeds with proportional 8-bit output).	1 byte	C	R	-	T	-	-	Low
119	Proportional	Split/VRV 2 nd Stage heating fan	Used to send the proportional speed value to set on the split/VRV interface fan (if the fan is set for split/VRV management with proportional fan management).	1 byte	C	R	-	T	-	-	Low
120	Speed 1	2 nd Stage Heating Fan inputs	Used to force activation of fan coil speed V1 (if the selected fan has 3 speeds)	1 bit	C	-	W	-	U	-	Low
120	Speed 1	Split/VRV 2 nd Stage heating fan inputs	Used to force the speed 1 to send to the split/VRV interface or to receive operating feedback about the fan 1 (if the fan is set for split/VRV management with bits management of the fans).	1 bit	C	-	W	-	U	-	Low
121	Speed 2	2 nd Stage Heating Fan inputs	Used to force activation of fan coil speed V2 (if the selected fan has 3 speeds)	1 bit	C	-	W	-	U	-	Low
121	Speed 2	Split/VRV 2 nd Stage heating fan inputs	Used to force the speed 2 to send to the split/VRV interface or to receive operating feedback about the fan 2 (if the fan is set for split/VRV management with bits management of the fans).	1 bit	C	-	W	-	U	-	Low

Continued

C = Communication; R = Read; W = Write; T = Transmission; U = Enable update

Communication objects and ETS parameters

Continued

No.	ETS name	Function	Description	Type	Flag 1						Priority
					C	R	W	T	U	I	
122	Speed 3	2 nd Stage Heating Fan inputs	Used to force activation of fan coil speed V3 (if the selected fan has 3 speeds)	1 bit	C	-	W	-	U	-	Low
122	Speed 3	Split/VRV 2 nd Stage heating fan inputs	Used to force the speed 3 to send to the split/VRV interface or to receive operating feedback about the fan 3 (if the fan is set for split/VRV management with bits management of the fans with a speed value of 3 or more).	1 bit	C	-	W	-	U	-	Low
123	Speed 4	Split/VRV 2 nd Stage heating fan inputs	Used to force the speed 4 to send to the split/VRV interface or to receive operating feedback about the fan 4 (if the fan is set for split/VRV management with bits management of the fans with a speed value of 4 or more).	1 bit	C	-	W	-	U	-	Low
124	Speed 5	Split/VRV 2 nd Stage heating fan inputs	Used to force the speed 5 to send to the split/VRV interface or to receive operating feedback about the fan 5 (if the fan is set for split/VRV management with bits management of the fans with a speed value of 5).	1 bit	C	-	W	-	U	-	Low
125	Speed Off	2 nd Stage Heating Fan outputs	Used to read the deactivation status of all 3 speeds (if the selected fan has 3 speeds with bit output or for split/VRV management with bits management of the fans). The thermostat sends a 1 bit when the fan is off (fan coil speed 0).	1 bit	C	R	-	T	-	-	Low
126	Speed 1	2 nd Stage Heating Fan outputs	This is the object to pair with the relay of speed 1 of the fan coil (in addition to controlling speed V1, it allows you to read the status of speed V1 of the fan coil)	1 bit	C	R	-	T	-	-	Low
126	Speed 1	Split/VRV 2 nd Stage heating fan outputs	To control or read the status of speed 1 of the split/VRV interface (if the fan is set for split/VRV management with bits management of the fans).	1 bit	C	R	-	T	-	-	Low
127	Speed 2	2 nd Stage Heating Fan outputs	This is the object to pair with the relay of speed 2 of the fan coil (in addition to controlling speed V2, it allows you to read the status of speed V2 of the fan coil)	1 bit	C	R	-	T	-	-	Low
127	Speed 2	Split/VRV 2 nd Stage heating fan outputs	To control or read the status of speed 2 of the split/VRV interface (if the fan is set for split/VRV management with bits management of the fans).	1 bit	C	R	-	T	-	-	Low
128	Speed 3	2 nd Stage Heating Fan outputs	This is the object to pair with the relay of speed 3 of the fan coil (in addition to controlling speed V3, it allows you to read the status of speed V3 of the fan coil)	1 bit	C	R	-	T	-	-	Low
128	Speed 3	Split/VRV 2 nd Stage heating fan outputs	To control or read the status of speed 3 of the split/VRV interface (if the fan is set for split/VRV management with bits management of the fans and speed value of 3 or more).	1 bit	C	R	-	T	-	-	Low
129	Speed 4	Split/VRV 2 nd Stage heating fan outputs	To control or read the status of speed 4 of the split/VRV interface (if the fan is set for split/VRV management with bits management of the fans and speed value of 4 or more).	1 bit	C	R	-	T	-	-	Low
130	Speed 5	Split/VRV 2 nd Stage heating fan outputs	To control or read the status of speed 5 of the split/VRV interface (if the fan is set for split/VRV management with bits management of the fans and speed value of 5 or more).	1 bit	C	R	-	T	-	-	Low
131	Enum speed	Split/VRV 2 nd Stage heating fan inputs	Used to force - via a value chosen in the parameters - a speed to send to the split/VRV interface or to receive operating feedback about a fan (if the fan is set for split/VRV management with enum management of the fans).	1 bit	C	-	W	-	U	-	Low
132	Enum speed info	Split/VRV 2 nd Stage heating fan outputs	To control or read the status of the speeds of the split/VRV interface (if the fan is set for split/VRV management with enum management of the fans).	1 bit	C	R	-	T	-	-	Low
133	Generic fan speed	Split/VRV 2 nd Stage heating fan outputs	To control the split/VRV interface via a proportional object type 5.001 (if the fan is set for split/VRV management with proportional fan management).	1 bit	C	R	-	T	-	-	Low
134	Speed 1	Disable 2 nd Stage Heating Fan	To disable speed V1 (if the selected fan has 3 speeds)	1 bit	C	R	W	T	U	-	Low
134	Speed 2	Disable 2 nd Stage Heating Fan	To disable speed V2 (if the selected fan has 3 speeds)	1 bit	C	R	W	T	U	-	Low

Continued

C = Communication; R = Read; W = Write; T = Transmission; U = Enable update

Communication objects and ETS parameters

Continued

No.	ETS name	Function	Description	Type	Flag 1						Priority
					C	R	W	T	U	I	
135	Speed 3	Disable 2 nd Stage Heating Fan	To disable speed V3 (if the selected fan has 3 speeds)	1 bit	C	R	W	T	U	-	Low
136	Split/VRV ON/OFF	Split/VRV 2 nd Stage heating ON/OFF	To turn the split/VRV interface on and off if the temperature control logic is performed by the thermostat, enabling the Split/VRV parameter controlled by the thermostat (if the fan is set for split/VRV management).	1 bit	C	R	-	T	-	-	Low
137	Split/VRV Info ON/OFF	Split/VRV 2 nd Stage heating Info On/Off	Used to force the split/VRV interface switch-ON or to receive ON/OFF feedback (if the fan is set for split/VRV management).	1 bit	C	-	W	-	U	-	Low
138	Fan coil: Automatic/Manual	Manual Heating operation	Used to set the operation of the fans in manual or automatic (if the fan is set for 3-speed fan coil).	1 bit	C	-	W	-	U	-	Low
140	Fan coil: Automatic/Manual	2 nd Stage Heating Manual Operation	To see whether the guest has altered the fan speed with respect to the default setting	1 bit	C	R	-	T	-	-	Low
141	Fan trigger	2 nd Stage Heating Fan inputs	To switch from one speed to the next upon receipt of either a 0 or a 1 bit	1 bit	C	-	W	-	U	-	Low
141	Fan trigger	Split/VRV 2 nd Stage heating fan Trigger	Used to receive the fan speed increase control to send to the split/VRV interface.	1 bit	C	-	W	-	U	-	Low
142	Speed step	Split/VRV 2 nd Stage heating fan inputs	To increase or decrease the speed of the fans in the case of split/VRV system management	1 bit	C	-	W	-	U	-	Low
143	Mode trigger	Split/VRV 2 nd Stage heating Mode	To move on to the next mode upon receipt of either a 0 bit or a 1 bit for the management of split/VRV systems (the available modes are decided during configuration)	1 bit	C	-	W	-	U	-	Low
144	Fan coil: Automatic/Manual	Split/VRV 2 nd Stage heating manual operation	Used to set the operation of the fans in manual or automatic (if the fan is set for split/VRV management).	1 bit	C	-	W	-	U	-	Low
145	Fan coil: Automatic/Manual	Split/VRV heating manual operation	Used to send the split/VRV interface the automatic or manual operation control of the VRV interface.	1 bit	C	R	-	T	-	-	Low
146	Step mode	Split/VRV 2 nd Stage heating Mode	To move on to the next mode or the previous mode in the management of split/VRV systems (the available modes are decided during configuration if the control logic is performed by the thermostat. If the logic is handled by the split/VRV system, the available modes are AUTO=0, HEAT=1, COOL=3, FAN=9, DRY=14).	1 bit	C	-	W	-	U	-	Low
147	Mode	Split/VRV 2 nd Stage heating Mode	To force an operating mode in the management of split/VRV systems (the available modes are decided during configuration if the control logic is performed by the thermostat. If the logic is handled by the split/VRV system, the available modes are AUTO=0, HEAT=1, COOL=3, FAN=9, DRY=14).	1 byte	C	-	W	-	U	-	Low
148	Mode info	Split/VRV 2 nd Stage heating Mode	To control or read an operating mode in the management of split/VRV systems (the available modes are decided during configuration if the control logic is performed by the thermostat. If the logic is handled by the split/VRV system, the available modes are AUTO=0, HEAT=1, COOL=3, FAN=9, DRY=14).	1 byte	C	-	W	-	U	-	Low
2nd Stage Cooling Fan											
149	Proportional (0- 100%)	2 nd Stage Cooling Fan inputs	Used to set a proportional speed for the fan coil fan (if the selected fan is proportional or with 3 speeds with proportional 8-bit output) via a supervisor (e.g., touch screen)	1 byte	C	-	W	-	U	-	Low
149	Proportional	Split/VRV heating fan	Used to receive the proportional speed value to set on the split/VRV interface fan or to receive feedback from the split/VRV interface (if the fan is set for split/VRV management with proportional fan management).	1 byte	C	-	W	-	U	-	Low
150	Proportional (0- 100%)	2 nd Stage Cooling Fan outputs	Used to send a proportional speed for the fan coil fan (if the selected fan is proportional or with 3 speeds with proportional 8-bit output).	1 byte	C	R	-	T	-	-	Low

Continued

C = Communication; R = Read; W = Write; T = Transmission; U = Enable update

Communication objects and ETS parameters

Continued

No.	ETS name	Function	Description	Type	Flag 1						Priority
					C	R	W	T	U	I	
150	Proportional	Split/VRV 2 nd Stage Cooling fan	Used to send the proportional speed value to set on the split/VRV interface fan (if the fan is set for split/VRV management with proportional fan management).	1 byte	C	R	-	T	-	-	Low
151	Speed 1	2 nd Stage Cooling Fan inputs	Used to force activation of fan coil speed V1 (if the selected fan has 3 speeds)	1 bit	C	-	W	-	U	-	Low
151	Speed 1	Split/VRV 2 nd Stage Cooling fan inputs	Used to force the speed 1 to send to the split/VRV interface or to receive operating feedback about the fan 1 (if the fan is set for split/VRV management with bits management of the fans).	1 bit	C	-	W	-	U	-	Low
152	Speed 2	2 nd Stage Cooling Fan inputs	Used to force activation of fan coil speed V2 (if the selected fan has 3 speeds)	1 bit	C	-	W	-	U	-	Low
152	Speed 2	Split/VRV 2 nd Stage Cooling fan inputs	Used to force the speed 2 to send to the split/VRV interface or to receive operating feedback about the fan 2 (if the fan is set for split/VRV management with bits management of the fans).	1 bit	C	-	W	-	U	-	Low
153	Speed 3	2 nd Stage Cooling Fan inputs	Used to force activation of fan coil speed V3 (if the selected fan has 3 speeds)	1 bit	C	-	W	-	U	-	Low
153	Speed 3	Split/VRV 2 nd Stage Cooling fan inputs	Used to force the speed 3 to send to the split/VRV interface or to receive operating feedback about the fan 3 (if the fan is set for split/VRV management with bits management of the fans with a speed value of 3 or more).	1 bit	C	-	W	-	U	-	Low
154	Speed 4	Split/VRV 2 nd Stage Cooling fan inputs	Used to force the speed 4 to send to the split/VRV interface or to receive operating feedback about the fan 4 (if the fan is set for split/VRV management with bits management of the fans with a speed value of 4 or more).	1 bit	C	-	W	-	U	-	Low
155	Speed 5	Split/VRV 2 nd Stage Cooling fan inputs	Used to force the speed 5 to send to the split/VRV interface or to receive operating feedback about the fan 5 (if the fan is set for split/VRV management with bits management of the fans with a speed value of 5).	1 bit	C	-	W	-	U	-	Low
156	Speed Off	2 nd Stage Cooling Fan outputs	Used to read the deactivation status of all 3 speeds (if the selected fan has 3 speeds with bit output or for split/VRV management with bits management of the fans). The thermostat sends a 1 bit when the fan is off (fan coil speed 0).	1 bit	C	R	-	T	-	-	Low
157	Speed 1	2 nd Stage Cooling Fan outputs	This is the object to pair with the relay of speed 1 of the fan coil (in addition to controlling speed V1, it allows you to read the status of speed V1 of the fan coil)	1 bit	C	R	-	T	-	-	Low
157	Speed 1	Split/VRV 2 nd Stage Cooling fan Outputs	To control or read the status of speed 1 of the split/VRV interface (if the fan is set for split/VRV management with bits management of the fans).	1 bit	C	R	-	T	-	-	Low
158	Speed 2	2 nd Stage Cooling Fan outputs	This is the object to pair with the relay of speed 2 of the fan coil (in addition to controlling speed V2, it allows you to read the status of speed V2 of the fan coil)	1 bit	C	R	-	T	-	-	Low
158	Speed 2	Split/VRV 2 nd Stage Cooling fan Outputs	To control or read the status of speed 2 of the split/VRV interface (if the fan is set for split/VRV management with bits management of the fans).	1 bit	C	R	-	T	-	-	Low
159	Speed 3	2 nd Stage Cooling Fan outputs	This is the object to pair with the relay of speed 3 of the fan coil (in addition to controlling speed V3, it allows you to read the status of speed V3 of the fan coil)	1 bit	C	R	-	T	-	-	Low
159	Speed 3	Split/VRV 2 nd Stage Cooling fan Outputs	To control or read the status of speed 3 of the split/VRV interface (if the fan is set for split/VRV management with bits management of the fans and speed value of 3 or more).	1 bit	C	R	-	T	-	-	Low
160	Speed 4	Split/VRV 2 nd Stage Cooling fan Outputs	To control or read the status of speed 4 of the split/VRV interface (if the fan is set for split/VRV management with bits management of the fans and speed value of 4 or more).	1 bit	C	R	-	T	-	-	Low
161	Speed 5	Split/VRV 2 nd Stage Cooling fan Outputs	To control or read the status of speed 5 of the split/VRV interface (if the fan is set for split/VRV management with bits management of the fans and speed value of 5 or more).	1 bit	C	R	-	T	-	-	Low

Continued

C = Communication; R = Read; W = Write; T = Transmission; U = Enable update

Communication objects and ETS parameters

Continued

No.	ETS name	Function	Description	Type	Flag 1						Priority
					C	R	W	T	U	I	
162	Enum speed	Split/VRV 2 nd Stage Cooling fan inputs	Used to force - via a value chosen in the parameters - a speed to send to the split/VRV interface or to receive operating feedback about a fan (if the fan is set for split/VRV management with enum management of the fans).	1 bit	C	-	W	-	U	-	Low
163	Enum speed info	Split/VRV 2 nd Stage Cooling fan Outputs	To control or read the status of the speeds of the split/VRV interface (if the fan is set for split/VRV management with enum management of the fans).	1 bit	C	R	-	T	-	-	Low
164	Generic fan speed	Split/VRV 2 nd Stage Cooling fan Outputs	To control the split/VRV interface via a proportional object type 5.001 (if the fan is set for split/VRV management with proportional fan management).	1 bit	C	R	-	T	-	-	Low
165	Speed 1	Disable 2 nd Stage Cooling Fan	To disable speed V1 (if the selected fan has 3 speeds)	1 bit	C	R	W	T	U	-	Low
165	Speed 2	Disable 2 nd Stage Cooling Fan	To disable speed V2 (if the selected fan has 3 speeds)	1 bit	C	R	W	T	U	-	Low
166	Speed 3	Disable 2 nd Stage Cooling Fan	To disable speed V3 (if the selected fan has 3 speeds)	1 bit	C	R	W	T	U	-	Low
167	Split/VRV ON/OFF	Split/VRV 2 nd Stage Cooling ON/OFF	To turn the split/VRV interface on and off if the temperature control logic is performed by the thermostat, enabling the Split/VRV parameter controlled by the thermostat (if the fan is set for split/VRV management).	1 bit	C	R	-	T	-	-	Low
168	Split/VRV Info ON/OFF	Split/VRV 2 nd Stage Cooling Info On/Off	Used to force the split/VRV interface switch-ON or to receive ON/OFF feedback (if the fan is set for split/VRV management).	1 bit	C	-	W	-	U	-	Low
169	Fan coil: Automatic/Manual	Manual Cooling operation	Used to set the operation of the fans in manual or automatic.	1 bit	C	-	W	-	U	-	Low
171	Fan coil: Automatic/Manual	2 nd Stage Cooling Manual Operation	To see whether the guest has altered the fan speed with respect to the default setting	1 bit	C	R	-	T	-	-	Low
172	Fan trigger	2 nd Stage Cooling Fan inputs	To switch from one speed to the next upon receipt of either a 0 or a 1 bit	1 bit	C	-	W	-	U	-	Low
172	Fan trigger	Split/VRV Cooling fan Trigger	Used to receive the fan speed increase control to send to the split/VRV interface.	1 bit	C	-	W	-	U	-	Low
173	Speed step	2 nd Stage Cooling Fan inputs	To increase or decrease the speed of the fans in the case of split/VRV system management	1 bit	C	-	W	-	U	-	Low
174	Mode trigger	Split/VRV 2 nd Stage Cooling Mode	To move on to the next mode upon receipt of either a 0 bit or a 1 bit for the management of split/VRV systems (the available modes are decided during configuration)	1 bit	C	-	W	-	U	-	Low
175	Fan coil: Automatic/Manual	Split/VRV 2 nd Stage Cooling manual operation	Used to set the operation of the fans in manual or automatic (if the fan is set for split/VRV management).	1 bit	C	-	W	-	U	-	Low
176	Fan coil: Automatic/Manual	Split/VRV heating manual operation	Used to send the split/VRV interface the automatic or manual operation control of the VRV interface. If "Split/VRV controlled by the thermostat" is set to "Yes", the value is always manual.	1 bit	C	R	-	T	-	-	Low
177	Step mode	Split/VRV 2 nd Stage Cooling Mode	To move on to the next mode or the previous mode in the management of split/VRV systems (the available modes are decided during configuration if the control logic is performed by the thermostat. If the logic is handled by the split/VRV system, the available modes are AUTO=0, HEAT=1, COOL=3, FAN=9, DRY=14).	1 bit	C	-	W	-	U	-	Low
178	Mode	Split/VRV 2 nd Stage Cooling Mode	To force an operating mode in the management of split/VRV systems (the available modes are decided during configuration if the control logic is performed by the thermostat. If the logic is handled by the split/VRV system, the available modes are AUTO=0, HEAT=1, COOL=3, FAN=9, DRY=14).	1 byte	C	-	W	-	U	-	Low
179	Mode info	Split/VRV 2 nd Stage Cooling Mode	To control or read an operating mode in the management of split/VRV systems (the available modes are decided during configuration if the control logic is performed by the thermostat. If the logic is handled by the split/VRV system, the available modes are AUTO=0, HEAT=1, COOL=3, FAN=9, DRY=14).	1 byte	C	-	W	-	U	-	Low

Continued

C = Communication; R = Read; W = Write; T = Transmission; U = Enable update

Communication objects and ETS parameters

Continued

No.	ETS name	Function	Description	Type	Flag 1						Priority
					C	R	W	T	U	I	
180	Humidity input for dewpoint calculation	Dewpoint	To know and view the humidity read by a KNX probe connected to the bus to calculate the dewpoint. Object available if the dewpoint calculation takes place locally, with the humidity sensor from the Bus and a 1 byte object.	1 byte	C	-	W	-	U	-	Low
180	Humidity input for dewpoint calculation	Dewpoint	To know and view the humidity read by a KNX probe connected to the bus to calculate the dewpoint. Object available if the dewpoint calculation takes place locally, with the humidity sensor from the Bus and a 2 byte object.	2 byte	C	-	W	-	U	-	Low
181	Delivery temperature	Dewpoint	To receive the delivery temperature from the Bus to calculate the dewpoint. Object available if the dewpoint calculation takes place locally and the delivery temperature reception parameter is enabled.	2 byte	C	-	W	-	U	-	Low
182	Room temperature	Dewpoint	To receive the room temperature from a probe connected to the Bus to calculate the dewpoint. Object available if the dewpoint calculation takes place locally and the delivery temperature reception parameter is enabled.	2 byte	C	-	W	-	U	-	Low
183	Dewpoint temperature	Dewpoint	To transmit or read the dewpoint temperature calculated internally. Object available if the dewpoint calculation takes place locally.	2 byte	C	R	-	T	-	-	Low
184	Dewpoint alarm	Dewpoint	To transmit a dewpoint alarm on the Bus. Object available if the dewpoint is calculated internally.	1 bit	C	R	-	T	-	-	Low
184	Dewpoint alarm	Dewpoint	If a 1 bit is sent to this object, the thermostat is set to OFF-PROTECTED and stops the air conditioner (it only works in air conditioning, and is used for instance to avoid condensation forming on the floor). Object available only if you have chosen the alarm to come from the bus and is therefore not calculated internally - Note: The thermostat requires a cyclic transmission to this object, with a time that can be set in the parameter "Dewpoint Supervision Time"	1 bit	C	-	W	-	U	-	Low
185	Amber LED ON	Room Number	To turn the amber LED on the device ON and OFF with a signalling bit (for instance, Do Not Disturb). Object available if the main function is Room Number	1 bit	C	-	W	-	U	-	Low
185	View Trigger	View	To view the values (internal temperature, external temperature, humidity and air quality) on the device upon receipt of either a 0 or a 1 bit. Object not available if the main function is Room Number or Buttons	1 bit	C	-	W	-	U	-	Low
186	°C/°F Trigger	Celsius/Fahrenheit	To change the temperature measurement unit upon receipt of either a 0 or a 1 bit. Object not available if the main function is Room Number	1 bit	C	-	W	-	U	-	Low
187	Buttons	Controls wake-up event	To send an ON message on pressing a button (normally used to wake up a button that performs the same function)	1 bit	C	R	-	T	-	-	Low
188	Temperature: disable local operation	Manual operation	To disable the possibility of using front buttons from the Bus. Object available if the main function is Master or Slave Thermostat. Upon receipt of a 1 bit any setpoint shift is also set to zero.	1 bit	C	-	W	-	U	-	Low
189	Button press	Room Number	To send an ON message upon pressing a button and OFF upon its release (normally used for the bell function). Object available if the main function is Room Number and the bell is enabled.	1 bit	C	R	-	T	-	-	Low
189	External temperature to view	Display	To receive the external temperature to view on the display (the other values to view are the internal temperature, humidity and air quality).	2 byte	C	-	W	-	U	-	Low
190	VIP enabling	VIP Function	To exclude the restrictions present in the Guest control permitted parameter for a VIP customer. Object available if the main function is Master or Slave Thermostat. After the receipt of a 1 the customer can control at their discretion, upon receipt of a 0 any setpoint shifts set are set to zero and the default setpoints are used.	1 bit	C	-	W	-	U	-	Low

Continued

C = Communication; R = Read; W = Write; T = Transmission; U = Enable update

Communication objects and ETS parameters

Continued

No.	ETS name	Function	Description	Type	Flag 1						Priority
					C	R	W	T	U	I	
191	Air quality index input	Air quality	To receive the air quality index from another sensor (0=stable air, 1=air worsening, 2=air rapidly worsening).	1 byte	C	-	W	-	U	-	Low
192	Air quality index	Air quality	To transmit the air quality index (0=stable air, 1=air worsening, 2=air rapidly worsening).	1 byte	C	R	-	T	-	-	Low
194	Control air quality sensor	Air quality	To transmit an ON/OFF control upon a change in the air quality according to a logic decided on during configuration.	1 bit	C	R	-	T	-	-	Low
195	Control air quality sensor	Air quality	To call up a scenario as the air quality worsens.	1 byte	C	R	-	T	-	-	Low
196	Control air quality sensor	Air quality	To call up a scenario as the air quality improves.	1 byte	C	R	-	T	-	-	Low
197	Control air quality sensor	Air quality	To transmit a proportional value upon a change in the air quality according to a logic decided on during configuration.	1 byte	C	R	-	T	-	-	Low
198	Humidity input	Humidity	To receive the humidity. Useful to calculate the dewpoint or for viewing.	2 byte	C	-	W	-	U	-	Low
198	Humidity input	Humidity	To receive the humidity. Useful to calculate the dewpoint or for viewing.	1 byte	C	-	W	-	U	-	Low
199	Humidity output	Humidity	To transmit the humidity read by the internal sensor.	2 byte	C	R	-	T	-	-	Low
199	Humidity output	Humidity	To transmit the humidity read by the internal sensor	1 byte	C	R	-	T	-	-	Low
200	Humidity control 1	Humidity	To transmit a 1 bit ON/OFF control according to a logic decided on during configuration.	1 bit	C	R	-	T	-	-	Low
201	Humidity control 2	Humidity	To transmit a 1 bit ON/OFF control according to a logic decided on during configuration.	1 bit	C	R	-	T	-	-	Low
202	Upper button	Value to send	(if set as "Push button" and the "switching 1 object" function is selected) - to send "ON/OFF/timed ON" messages.	1 bit	C	R	-	T	-	-	Low
202	Upper button	Value to send	(if set as "Push button" and the "Trigger Control" function is selected) - to send trigger type messages	1 bit	C	R	-	T	-	-	Low
202	Upper button	Sends value - short press	(if set as "Push button" and "Switching module with multiple objects/Short-Long press" function) - to send "Toggle/send ON/send OFF" messages with short press: if used in Toggle mode, also associate the object of "ON/OFF status" of the button in the same group as this object.	1 bit	C	R	-	T	-	-	Low
202	Upper button	Send forcing - short press	(if set as "Push button" and "Switching module with multiple objects/Forcing" function) to send one of the forcing functions for selection as "forcing On/forcing OFF/Forced disable"	2 bit	C	R	-	T	-	-	Low
202	Upper button	Send value - up	(if set as "Push button" and "Switching module with multiple objects/on the edge" function) to send one of functions for selection as "ON/OFF on the rising edge" (pressing the button)	1 bit	C	R	-	T	-	-	Low
202	Upper button	Scenario - short press	(if set as "Push button" and "Switching module with multiple objects/Short-long press/call up or store scenario" function) to call up or store a scenario on short press.	1 byte	C	R	-	T	-	-	Low
202	Upper button	Send value - short press	(if set as "Push button" and "Switching module with multiple objects/Value" function) to send a value that can be set between 0 and 255 on short press.	1 byte	C	R	-	T	-	-	Low
202	Upper button	ON/OFF control	(if set as "Push button" and "Single push button dimming" function) to control a dimmed light	1 bit	C	R	-	T	-	-	Low
202	Upper button	Roller shutter Up/Down	(if set as "Push button" and "Single push button roller shutter control" function) to operate a roller shutter with a single button.	1 bit	C	R	-	T	-	-	Low
202	Upper button	Short sequence - Value 1	(if set as "Push button" and "Switching module with multiple objects/Sequence" function) - to send the first 1 bit or 1 byte sequence message on short press.	1 bit 1 byte	C	R	-	T	-	-	Low

Continued

C = Communication; R = Read; W = Write; T = Transmission; U = Enable update

Communication objects and ETS parameters

Continued

No.	ETS name	Function	Description	Type	Flag 1						Priority
					C	R	W	T	U	I	
202	Upper button	Multiple press - Value 1	(if set as "Push button" and "Switching module with multiple objects/Multiple presses" function) - to send a message at the first event of multiple presses.	1 bit 1 byte 2 byte	C	R	-	T	-	-	Low
203	Upper button	Sends value - long press	(if set as "Push button" and "short/long press" function) - to send "Toggle/send ON/send OFF" messages with long press: if used in Toggle mode, also associate the object of "ON/OFF status-long press" of the button in the same group as this object.	1 bit	C	R	-	T	-	-	Low
203	Upper button	Slats up down/ roller shutter stop	(if set as "Push button" and "Roller shutter single push button control" function) - to stop the roller shutter.	1 bit	C	R	-	T	-	-	Low
203	Upper button	Send value - long press	(if set as "Push button" and "Switching module with multiple objects/Value" function) - to send a value that can be set between 0 and 255 on long press.	1 byte	C	R	-	T	-	-	Low
203	Upper button	Dimmer control	(if set as "Push button" and "Single push button dimming" function) to control a dimmed light	4 bit	C	R	-	T	-	-	Low
203	Upper button	Send value - down	(if set as "Push button" and "Switching module with multiple objects/on the edge" function) to send one of functions for selection as "ON/OFF on the falling edge (release the button)	1 bit	C	R	-	T	-	-	Low
203	Upper button	Send forcing - long press	(if set as "Push button" and "Switching module with multiple objects/Forcing" function) to send one of the forcing functions for selection as "forcing On/forcing OFF/Forced disable"	2 bit	C	R	-	T	-	-	Low
203	Upper button	Scenario - long press	(if set as "Push button" and "Switching module with multiple objects/Short-long press/call up or store scenario" function) to call up or store a scenario on long press.	1 byte	C	R	-	T	-	-	Low
203	Upper button	Short sequence - Value 2	(if set as "Push button" and "Switching module with multiple objects/Sequence" function) - to send the second 1 bit sequence message on short press.	1 Bit	C	R	-	T	-	-	Low
203	Upper button	Multiple press - Value 2	(if set as "Push button" and "Switching module with multiple objects/Multiple presses" function) - to send a message at the second event of multiple presses.	1 bit 1 byte 2 byte	C	R	-	T	-	-	Low
204	Upper button	Short sequence - Value 3	(if set as "Push button" and "Switching module with multiple objects/Sequence" function) - to send the third 1 bit sequence message on short press.	1 bit	C	R	-	T	-	-	Low
204	Upper button	Multiple press - Value 3	(if set as "Push button" and "Switching module with multiple objects/Multiple presses" function) - to send a message at the third event of multiple presses.	1 bit 1 byte 2 byte	C	R	-	T	-	-	Low
205	Upper button	ON/OFF status	(if set as "Push button" and "Switching module with multiple objects/on the edge" function selected) to turn on the LED to show the status of the load or the value of the object.	1 bit	C		W		U	-	Low
205	Upper button	ON/OFF status	(if set as "Push button" and "Switching 1 object" function selected) to turn on the LED to show the status of the load or the value of the object.	1 bit	C		W		U	-	Low
205	Upper button	ON/OFF status	(if set as "Push button" and "Switching module with multiple objects/Forcing" function selected) to turn on the LED to show the status of the load.	1 bit	C		W		U	-	Low
205	Upper button	ON/OFF status ON/OFF status - short press Roller shutter status	(if set as "Push button" and "Single push button dimming" function or "Switching module with multiple objects/Short-long press/toggle" or "Roller shutter single push button control" function selected) this object must be associated with the group with the light "ON/OFF control" datapoint (relay or dimmer) or the roller shutter "roller shutter up/down" datapoint to receive the ON/OFF status of the associated load. If this is not the case, it will be unable to manage light control or roller shutter operation.	1 bit	C		W		U	-	Low
205	Upper button	Multiple press - Value 4	(if set as "Push button" and "Switching module with multiple objects/Multiple presses" function) - to send a message at the fourth event of multiple presses.	1 bit 1 byte 2 byte	C	R	-	T	-	-	Low

Continued

C = Communication; R = Read; W = Write; T = Transmission; U = Enable update

Communication objects and ETS parameters

Continued

No.	ETS name	Function	Description	Type	Flag 1						Priority
					C	R	W	T	U	I	
205	Upper button	Short sequence - Value 4	(if set as "Push button" and "Switching module with multiple objects/Sequence" function) - to send the fourth 1 bit sequence message on short press.	1 bit	C	R	-	T	-	-	Low
206	Upper button	ON/OFF status - long press	(if set as "Push button" and "Switching module with multiple objects/Short-long press/toggle" function) - this object must be associated with the group with the light "ON/OFF control" datapoint on long press to receive the ON/OFF status of the associated load. If this is not the case, it will be unable to manage light control.	1 bit	C	-	W	-	U	-	Low
206	Upper button	Long sequence - Value 1	(if set as "Push button" and "Switching module with multiple objects/Sequence" function) - to send the first 1 bit or 1 byte sequence message on long press.	1bit 1byte	C	R	-	T	-	-	Low
206	Upper button	Multiple press - Value 5 long press	(if set as "Push button" and "Switching module with multiple objects/Multiple presses" function selected) to send a message in the event of long press.	1 bit	C	R	-	T	-	-	Low
206	Upper button	Multiple press - Value 5 long press	(if set as "Push button" and "Switching module with multiple objects/Multiple presses" function selected) to call up/store a scenario in the event of long press.	1byte	C	R	-	T	-	-	Low
207	Upper button	Long sequence - Value 2	(if set as "Push button" and "Switching module with multiple objects/Sequence" function) - to send the second 1 bit sequence message on long press.	1 bit	C	R	-	T	-	-	Low
207	Upper button	ON/OFF status - Multiple press 1	(if set as "Push button" and "Switching module with multiple objects/Multiple presses" function selected) required for Toggle mode.	1 bit	C	-	W	-	U	-	Low
208	Upper button	Long sequence - Value 3	(if set as "Push button" and "Switching module with multiple objects/Sequence" function) - to send the third 1 bit sequence message on long press.	1 bit	C	R	-	T	-	-	Low
208	Upper button	ON/OFF status - Multiple press 2	(if set as "Push button" and "Switching module with multiple objects/Multiple presses" function selected) required for Toggle mode.	1 bit	C	-	W	-	U	-	Low
209	Upper button	Long sequence - Value 4	(if set as "Push button" and "Switching module with multiple objects/Sequence" function) - to send the fourth 1 bit sequence message on long press.	1 bit	C	R	-	T	-	-	Low
209	Upper button	ON/OFF status - Multiple press 3	(if set as "Push button" and "Switching module with multiple objects/Multiple presses" function selected) required for Toggle mode.	1 bit	C	-	W	-	U	-	Low
210	Upper button	ON/OFF status - Multiple press 4	(if set as "Push button" and "Switching module with multiple objects/Multiple presses" function selected) required for Toggle mode.	1 bit	C	-	W	-	U	-	Low
211	Upper button	ON/OFF status - Multiple press - long press	(if set as "Push button" and "Switching module with multiple objects/Multiple presses" function selected) required for Toggle mode in long press.	1 bit	C	-	W	-	U	-	Low
212	Upper button	Pressure feedback	to send an ON control on pressing the button (normally used to wake up a button that performs the same function).	1 bit	C	R	-	T	-	-	Low
213	Upper button	Object block	(With any function/sub-function, if the "Block" parameter is on) - to block the button operation via a settable bit at 1 or at 0.	1 bit	C	-	W	-	U	-	Low
214	Upper button	LED status	(With any function/sub-function, if the "Block" parameter is on) - to block the button operation via a settable bit at 1 or at 0.	1 bit	C	-	W	-	U	-	Low
214	Upper button	LED status	(if set as "Push button" and "View Only" function selected) - to turn the LED on and off with a 1 bit object.	1 bit	C	-	W	-	U	-	Low
215	Lower button	Value to send	(if set as "Push button" and the "switching 1 object" function is selected) - to send "ON/OFF/timed ON" messages.	1 bit	C	R	-	T	-	-	Low
215	Lower button	Value to send	(if set as "Push button" and the "Trigger Control" function is selected) - to send trigger type messages	1 bit	C	R	-	T	-	-	Low

Continued

C = Communication; R = Read; W = Write; T = Transmission; U = Enable update

Communication objects and ETS parameters

Continued

No.	ETS name	Function	Description	Type	Flag 1						Priority
					C	R	W	T	U	I	
215	Lower button	Sends value - short press	(if set as "Push button" and "Switching module with multiple objects/Short-Long press" function) - to send "Toggle/send ON/send OFF" messages with short press: if used in Toggle mode, also associate the object of "ON/OFF status" of the button in the same group as this object.	1 bit	C	R	-	T	-	-	Low
215	Lower button	Send forcing - short press	(if set as "Push button" and "Switching module with multiple objects/Forcing" function) to send one of the forcing functions for selection as "forcing On/forcing OFF/Forced disable"	2 bit	C	R	-	T	-	-	Low
215	Lower button	Send value - up	(if set as "Push button" and "Switching module with multiple objects/on the edge" function) to send one of functions for selection as "ON/OFF on the rising edge" (pressing the button)	1 bit	C	R	-	T	-	-	Low
215	Lower button	Scenario - short press	(if set as "Push button" and "Switching module with multiple objects/Short-long press/call up or store scenario" function) to call up or store a scenario on short press.	1 byte	C	R	-	T	-	-	Low
215	Lower button	Send value - short press	(if set as "Push button" and "Switching module with multiple objects/Value" function) to send a value that can be set between 0 and 255 on short press.	1 byte	C	R	-	T	-	-	Low
215	Lower button	ON/OFF control	(if set as "Push button" and "Single push button dimming" function) to control a dimmed light	1 bit	C	R	-	T	-	-	Low
215	Lower button	Roller shutter Up/Down	(if set as "Push button" and "Single push button roller shutter control" function) to operate a roller shutter with a single button.	1 bit	C	R	-	T	-	-	Low
215	Lower button	Short sequence - Value 1	(if set as "Push button" and "Switching module with multiple objects/Sequence" function) - to send the first 1 bit or 1 byte sequence message on short press.	1 bit 1 byte	C	R	-	T	-	-	Low
215	Lower button	Multiple press - Value 1	(if set as "Push button" and "Switching module with multiple objects/Multiple presses" function) - to send a message at the first event of multiple presses.	1 bit 1 byte 2 byte	C	R	-	T	-	-	Low
216	Lower button	Sends value - long press	(if set as "Push button" and "short/long press" function) - to send "Toggle/send ON/send OFF" messages with long press: if used in Toggle mode, also associate the object of "ON/OFF status-long press" of the button in the same group as this object.	1 bit	C	R	-	T	-	-	Low
216	Lower button	Slats up down/ roller shutter stop	(if set as "Push button" and "Roller shutter single push button control" function) - to stop the roller shutter.	1 bit	C	R	-	T	-	-	Low
216	Lower button	Send value - long press	(if set as "Push button" and "Switching module with multiple objects/Value" function) - to send a value that can be set between 0 and 255 on long press.	1 byte	C	R	-	T	-	-	Low
216	Lower button	Dimmer control	(if set as "Push button" and "Single push button dimming" function) to control a dimmed light	4 bit	C	R	-	T	-	-	Low
216	Lower button	Send value - down	(if set as "Push button" and "Switching module with multiple objects/on the edge" function) to send one of functions for selection as "ON/OFF on the falling edge (release the button)	1 bit	C	R	-	T	-	-	Low
216	Lower button	Send forcing - long press	(if set as "Push button" and "Switching module with multiple objects/Forcing" function) to send one of the forcing functions for selection as "forcing On/forcing OFF/Forced disable"	2 bit	C	R	-	T	-	-	Low
216	Lower button	Scenario - long press	(if set as "Push button" and "Switching module with multiple objects/Short-long press/call up or store scenario" function) to call up or store a scenario on long press.	1 byte	C	R	-	T	-	-	Low
216	Lower button	Short sequence - Value 2	(if set as "Push button" and "Switching module with multiple objects/Sequence" function) - to send the second 1 bit sequence message on short press.	1 Bit	C	R	-	T	-	-	Low

Continued

C = Communication; R = Read; W = Write; T = Transmission; U = Enable update

Communication objects and ETS parameters

Continued

No.	ETS name	Function	Description	Type	Flag 1						Priority
					C	R	W	T	U	I	
216	Lower button	Multiple press - Value 2	(if set as "Push button" and "Switching module with multiple objects/Multiple presses" function) - to send a message at the second event of multiple presses.	1 bit 1 byte 2 byte	C	R	-	T	-	-	Low
217	Lower button	Short sequence - Value 3	(if set as "Push button" and "Switching module with multiple objects/Sequence" function) - to send the third 1 bit sequence message on short press.	1 bit	C	R	-	T	-	-	Low
217	Lower button	Multiple press - Value 3	(if set as "Push button" and "Switching module with multiple objects/Multiple presses" function) - to send a message at the third event of multiple presses.	1 bit 1 byte 2 byte	C	R	-	T	-	-	Low
218	Lower button	ON/OFF status	(if set as "Push button" and "Switching module with multiple objects/on the edge" function selected) to turn on the LED to show the status of the load or the value of the object.	1 bit	C		W		U	-	Low
218	Lower button	ON/OFF status	(if set as "Push button" and "Switching 1 object" function selected) to turn on the LED to show the status of the load or the value of the object.	1 bit	C		W		U	-	Low
218	Lower button	ON/OFF status	(if set as "Push button" and "Switching module with multiple objects/Forcing" function selected) to turn on the LED to show the status of the load.	1 bit	C		W		U	-	Low
218	Lower button	ON/OFF status ON/OFF status - short press Roller shutter status	(if set as "Push button" and "Single push button dimming" function or "Switching module with multiple objects/Short-long press/toggle" or "Roller shutter single push button control" function selected) this object must be associated with the group with the light "ON/OFF control" datapoint (relay or dimmer) or the roller shutter "roller shutter up/down" datapoint to receive the ON/OFF status of the associated load. If this is not the case, it will be unable to manage light control or roller shutter operation.	1 bit	C		W		U	-	Low
218	Lower button	Multiple press - Value 4	(if set as "Push button" and "Switching module with multiple objects/Multiple presses" function) - to send a message at the fourth event of multiple presses.	1 bit 1 byte 2 byte	C	R	-	T	-	-	Low
218	Lower button	Short sequence - Value 4	(if set as "Push button" and "Switching module with multiple objects/Sequence" function) - to send the fourth 1 bit sequence message on short press.	1 bit	C	R	-	T	-	-	Low
219	Lower button	ON/OFF status - long press	(if set as "Push button" and "Switching module with multiple objects/Short-long press/toggle" function) - this object must be associated with the group with the light "ON/OFF control" datapoint on long press to receive the ON/OFF status of the associated load. If this is not the case, it will be unable to manage light control.	1 bit	C	-	W	-	U	-	Low
219	Lower button	Long sequence - Value 1	(if set as "Push button" and "Switching module with multiple objects/Sequence" function) - to send the first 1 bit or 1 byte sequence message on long press.	1bit 1byte	C	R	-	T	-	-	Low
219	Lower button	Multiple press - Value 5 long press	(if set as "Push button" and "Switching module with multiple objects/Multiple presses" function selected) to send a message in the event of long press.	1 bit	C	R	-	T	-	-	Low
219	Lower button	Multiple press - Value 5 long press	(if set as "Push button" and "Switching module with multiple objects/Multiple presses" function selected) to call up/store a scenario in the event of long press.	1byte	C	R	-	T	-	-	Low
220	Lower button	Long sequence - Value 2	(if set as "Push button" and "Switching module with multiple objects/Sequence" function) - to send the second 1 bit sequence message on long press.	1 bit	C	R	-	T	-	-	Low
220	Lower button	ON/OFF status - Multiple press 1	(if set as "Push button" and "Switching module with multiple objects/Multiple presses" function selected) required for Toggle mode.	1 bit	C	-	W	-	U	-	Low
221	Lower button	Long sequence - Value 3	(if set as "Push button" and "Switching module with multiple objects/Sequence" function) - to send the third 1 bit sequence message on long press.	1 bit	C	R	-	T	-	-	Low
221	Lower button	ON/OFF status - Multiple press 2	(if set as "Push button" and "Switching module with multiple objects/Multiple presses" function selected) required for Toggle mode.	1 bit	C	-	W	-	U	-	Low
222	Lower button	Long sequence - Value 4	(if set as "Push button" and "Switching module with multiple objects/Sequence" function) - to send the fourth 1 bit sequence message on long press.	1 bit	C	R	-	T	-	-	Low

Continued

C = Communication; R = Read; W = Write; T = Transmission; U = Enable update

Communication objects and ETS parameters

Continued

No.	ETS name	Function	Description	Type	Flag 1						Priority
					C	R	W	T	U	I	
222	Lower button	ON/OFF status - Multiple press 3	(if set as "Push button" and "Switching module with multiple objects/Multiple presses" function selected) required for Toggle mode.	1 bit	C	-	W	-	U	-	Low
223	Lower button	ON/OFF status - Multiple press 4	(if set as "Push button" and "Switching module with multiple objects/Multiple presses" function selected) required for Toggle mode.	1 bit	C	-	W	-	U	-	Low
224	Lower button	ON/OFF status - Multiple press - long press	(if set as "Push button" and "Switching module with multiple objects/Multiple presses" function selected) required for Toggle mode in long press.	1 bit	C	-	W	-	U	-	Low
225	Lower button	Pressure feedback	to send an ON control on pressing the button (normally used to wake up a button that performs the same function).	1 bit	C	R	-	T	-	-	Low
226	Lower button	Object block	(With any function/sub-function, if the "Block" parameter is on) - to block the button operation via a settable bit at 1 or at 0.	1 bit	C	-	W	-	U	-	Low
227	Lower button	LED status	(With any function/sub-function, if the "Block" parameter is on) - to block the button operation via a settable bit at 1 or at 0.	1 bit	C	-	W	-	U	-	Low
227	Lower button	LED status	(if set as "Push button" and "View Only" function selected) - to turn the LED on and off with a 1 bit object.	1 bit	C	-	W	-	U	-	Low
228	Buttons	ON/OFF	(if set as "Switching module" and the "On/Off switching" function is selected) - to send "On/Off" messages pressing the top/bottom or bottom/top part of the double push button respectively	1 bit	C	R	-	T	-	-	Low
228	Buttons	ON/OFF control	(if set as "Switching module" and "Dimmer control" function) to control a dimmed light.	1 bit	C	R	-	T	-	-	Low
228	Buttons	Roller shutter Up/Down	(if set as "Switching module" and "Roller shutters" function) to control the operation of a roller shutter.	1 bit	C	R	-	T	-	-	Low
229	Buttons	Dimmer control	(if set as "Switching module" and "Dimmer control" function) to control a dimmed light	4 bit	C	R	-	T	-	-	Low
229	Buttons	Venetian blind ON/OFF	(if set as "Switching module" and "Roller shutters" function) to stop a roller shutter or the movement of the slat.	1 bit	C	-	W	-	U	-	Low
230	Buttons	ON/OFF status	(if set as "Switching module" and "Power on/off" function selected with "Toggle" enabled) to have the toggle function on both buttons.	1 bit	C	-	W	-	U	-	Low
230	Buttons	Dimming On/Off status	(if set as "Switching module" and "Dimmer control" function selected) to be able to view the load status and have the toggle function on both buttons in the event the "Toggle" function is enabled.	1 bit	C	-	W	-	U	-	Low
231	Buttons	Absolute value Info	(if set as "Switching module" and "Dimmer control" function set) to be able to have information about the brightness of the load and thus view it on the device using one of the status icons described in the "Icons and animations" paragraph.	1 byte	C	-	W	-	U	-	Low
231	Buttons	Absolute value Info	(if set as "Switching module" and "Roller shutters" function set) to be able to receive information about the height of the roller shutter and view it on the device using one of the status icons described in the "Icons and animations" paragraph.	1 byte	C	-	W	-	U	-	Low
232	Buttons	Pressure feedback	to send an ON control on pressing one of the 2 buttons (normally used to wake up a button that performs the same function).	1 bit	C	R	-	T	-	-	Low
233	Buttons	Object block	(with any function/sub-function, if the "Block" parameter is on) - to block the button operation via a settable bit at 1 or at 0.	1 bit	C	-	W	-	U	-	Low
234	LED matrix	Switching On/Off	to switch the central LED matrix on and off in the event of "central LEDs/Function/On/Off".	1 bit	C	-	W	-	U	-	Low
234	LED matrix	Alarm	to switch the central LED matrix on and off with settable flashing in the event of "central LEDs/Function/Alarm".	1 bit	C	-	W	-	U	-	Low

Continued

C = Communication; R = Read; W = Write; T = Transmission; U = Enable update

Communication objects and ETS parameters

No.	ETS name	Function	Description	Type	Flag 1						Priority
					C	R	W	T	U	I	
235	LED matrix	Scenario	to provide scenario call up feedback via the brief switch-off of the central matrix.	1 bit	C	-	W	-	U	-	Low
236	LED matrix	Status	to send the status of the central LED matrix. The group address of this object must be different from that of "Switching On/Off" or "Alarm".	1 bit	C	R	-	T	-	-	Low
237	Device	Backlighting Wake-up	to receive the activation request from device stand-by.	1 bit	C	-	W	-	U	-	Low
238	Device	Proximity detection	(if "proximity sending on bus" active and "data type on bus" type "1 bit") to send a one bit control upon detection of the proximity sensor.	1 bit	C	R	-	T	-	-	Low
239	Device	Proximity detection	(if "proximity sending on bus" active and "data type on bus" type "Scenario") to call up a scenario upon detection of the proximity sensor.	1 byte	C	R	-	T	-	-	Low
240	Device	Day-Night	to receive information about whether it is day (=0) or night (=1).	1 bit	C	-	W	-	U	-	Low

C = Communication; **R** = Read; **W** = Write; **T** = Transmission; **U** = Enable update

Number of communication objects	Max. number of group addresses	Max. number of associations
240	254	255

Communication objects and ETS parameters

Reference ETS parameters

General

The General paragraph defines certain generic functions of the user interface regardless of the Main Function performed by the multisensor.

General Parameters

ETS text	Values available [Default value]	Comment
Main function	Thermostat: master	Used to select the main function performed by the multisensor.
	Thermostat: slave	
	Viewing only	
	Buttons	
	Buttons + Thermostat (no display)	
	Room number	
	[Thermostat: master]	
Debounce time	50...500 ms	Time during which the control ignores any status changes (minimum pressing time)
	[50]	
Time for long action	1...30 s	Minimum press time to perform the action associated with a long press
	[0.5 s]	
Return to standby time	10 s	Time to set to decide after how long without user interaction the device returns to standby
	15 s	
	20 s	
	30 s	
	45 s	
	60 s	
	Disable	
	[10 s]	
Receive backlighting wake-up upon pressing other controls	0 = Enable	Allows you to determine whether the device can be woken up by a message on the bus
	1 = Disable	
	[Disable]	
Backlighting wake-up value	0	Allows you to determine which value received from the bus can wake up the device
	1	
	Both	
	[Both]	
Activated day standby function brightness	Off	To choose the brightness on standby by day with device on
	Low	
	Medium	
	High	
	[High]	
Deactivated day standby function brightness	Off	To choose the brightness on standby by day with device off
	Low	
	Medium	
	High	
	[Low]	

Continued

Main Function Thermostat: master ▼

Debounce Time 50 ms

Time for long action 0,5 s ▼

Return to standby time 10s ▼

Receive backlighting wake-up on pressing other controls Disable Enable

Backlighting wake-up value 1 ▼

Activated day standby function brightness High ▼

Deactivated day standby function brightness Low ▼

Activated night standby function brightness Medium ▼

Deactivated night standby function brightness Low ▼

General

Continued

ETS text	Values available [Default value]	Comment
Activated night standby function brightness	Off	To choose the brightness on standby at night with device on
	Low	
	Medium	
	High	
	[Medium]	
Deactivated night standby function brightness	Off	To choose the brightness on standby at night with device off
	Low	
	Medium	
	High	
	[Low]	

Communication objects and ETS parameters

Proximity

The parameters for the proximity function must be considered for the entire device and not limited to the individual function. They allow you to set the sensitivity of the proximity and to decide whether to send a 1 bit message or call up a scenario upon proximity detection.

Proximity parameters

ETS text	Values available [Default value]	Comment
Proximity sensitivity	Disable	Allows you to set the presence detection sensitivity
	Low	
	Medium	
	High	
	[Medium]	
Sending proximity event on bus	Disable	To enable sending a message on the bus upon presence detection
	Enable	
	[Disable]	
Format of data to send on the bus for proximity	1 bit	Allows you to choose whether to send a 1 bit message or call up a scenario upon presence detection
	Scenario	
	[Scenario]	
Scenario	1..64	To choose the number of the scenario to call up
	[1]	

Proximity sensitivity

Sending proximity event on bus Disable Enable

Data format proximity on bus 1 bit Scene

Scene

Proximity

Device display

This paragraph describes the parameters to define the values shown on the display.

Multisensor Display Parameters

ETS text	Values available [Default value]	Comment
Temperature Unit of measure	Celsius	Used to select the temperature measurement unit when shown on the display
	Fahrenheit	
	[Celsius]	
Button Activation	Enable	You can choose whether to make the multisensor buttons operative
	Disable	
	[Enable]	
Upper icon	Off	Allows you to choose the icon shown by the LED matrix corresponding to the upper button
	More	
	Up arrow	
	More (small)	
	[Up arrow]	
Preview		Shows the image chosen in the "Upper icon" parameter
Lower icon	Off	Allows you to choose the icon shown by the LED matrix corresponding to the lower button
	Less	
	Down arrow	
	Minus (small)	
	[Down arrow]	

Continued

Temperature Unit Celsius Fahrenheit

Keys activation enable disable

Upper Icon

Preview 

Lower Icon

Preview 

Multisensor display

Continued

ETS text	Values available [Default value]	Comment
Preview		Shows the image chosen in the "lower icon" parameter

Communication objects and ETS parameters

Thermostat Setting

This paragraph describes the parameters to define the thermostat settings.

Thermostat Parameters

ETS text	Values available [Default value]	Comment
Thermostat function	Heating	Used to select whether the thermostat is used to control heating, cooling or both
	Cooling	
	Heating + Cooling	
	[Heating]	
Neutral zone	Enable	You can choose whether to enable the neutral zone. Only available if "Thermostat function" is equal to "Heating + Cooling"
	Disable	
	[Disable]	
Function after database download	Heating	Used to choose whether the thermostat is in "Heating" or "Cooling" after the database download via ETS.
	Cooling	
	[Heating]	
Mid season management	Enable	Used to enable the object to set the mid season from the supervisor. Mid season allows the primary to be inverted with the secondary if necessary.
	Disable	
	[Disable]	
Boost for heating	Enable	Used to decide whether the second heating stage works as a boost. If the parameter is set to "Disable" the second stage only works for "Mid season" if enabled from the parameter.
	Disable	
	[Disable]	
Boost for cooling	Enable	Used to decide whether the second cooling stage works as a boost. If the parameter is set to "Disable" the second stage only works for "Mid season" if enabled from the parameter.
	Disable	
	[Disable]	
Setpoint shift step	0.1°C, 0.2°C,, 1°C	Setpoint shift step upon receipt of a setpoint shift increase or decrease control.
	[1°C]	
Thermostat connection with the dewpoint	Enable	When this parameter is active, the dewpoint calculation only works if it is in an ON operating mode. If the parameter is deactivated, the dewpoint calculation always works.
	Disable	
	[Enable]	

Thermostat function Heating + Cooling ▾

Neutral zone enable disable

Function after database download Heating Cooling

Middle Season Management enable disable

Boost for heating enable disable

Boost for cooling enable disable

Setpoint shift step 1 °C ▾

Thermostat connection with dewpoint enable disable

Thermostat Setting

Communication objects and ETS parameters

Thermostat Display Configuration

This paragraph describes the parameters to define the display configuration for the thermostat function.

Thermostat Display Parameters

ETS text	Values available [Default value]	Comment
Displayed value	Show Room temperature	Used to choose whether to show the following on the display: the temperature detected; the current setpoint; the temperature delta with respect to the Setpoint set by design or no indication
	Current setpoint	
	Show difference from setpoint	
	Display Off	
	[Show room temperature]	
Heating LED visible	Yes	You can choose whether to display the LED that signals that the heating output is in control.
	No	
	[Yes]	
Cooling LED visible	Yes	You can choose whether to display the LED that signals that the cooling output is in control.
	No	
	[Yes]	
Monochrome	Enable	You can choose whether the LED that signals the output status is monochrome..
	Disable	
	[Enable]	
Step of the setpoint upon pressing the device buttons	0 = 0.1°C (0.2°F)	Step of the setpoint when pressing the buttons present on the multisensor.
	1 = 0.2°C (0.5°F)	
	2 = 0.5°C (1.0°F)	
	3 = 1.0°C (2.0°F)	
	[2 = 0.5°C (1.0°F)]	
Guest control permitted	Off	Determines how much the guest can change the setpoint from the value set on the thermostat (up/down)
	1.0°C	
	2.0°C	
	3.0°C	
	4.0°C	
	5.0°C	
	No limit	
[3.0°C]		

Displayed value Show actual temperature ▾

Heating LED visible No Yes

Air-conditioning LED visible No Yes

Monochromatic enable disable

Setpoint step pressing the device keys 0 = 0.1°C (0.2°F) ▾

Guest Permit Regulation 3,0 °C ▾

Thermostat Display Configuration

Communication objects and ETS parameters

Internal temperature sensor

Sensor parameters

ETS text	Values available [Default value]	Comment
Temperature offset	-2 °C ... +2 °C	Reading calibration of the thermostat's internal probe.
	[0]	
Send cycle time	Off, 30 s,, 30 min	Activates the cyclic transmission of object numb. 1 "Internal Sensor"
	[Off]	
Send difference	Off, 0.1 °C,, 1.0 °C	Sets the minimum measured temperature change with respect to the setpoint that will cause the thermostat to send the current value over the bus to a supervisor.
	[Off]	

Temperature Offset °C

Send Cycle Time

Send Difference

Internal temperature sensor

Thermostat

Current Temperature

ETS text	Values available [Default value]	Comment
Weight of the temperature sensors by day	0... 100	For the thermostat's internal sensor and the KNX probes, this determines the relative importance for calculating the weighted average of the measured temperatures
	[0]	
Weight of the temperature sensors at night	0... 100	For the thermostat's internal sensor and the KNX probes, this determines the relative importance for calculating the weighted average of the measured temperatures
	[0]	
Send cycle time	Off, 30 s,, 30 min	Sets the frequency in minutes with which the thermostat must send the measured temperature value (or the weighted average of the probes) over the bus to a supervisor. Activates the cyclic transmission of the thermostat's "Current Temperature" object
	[Off]	
Send difference	Off, 0.1 °C,, 1.0 °C	Sets the temperature difference measured by the thermostat that results in the read value (or the weighted average of the probes) being sent over the bus towards a supervisor. Activates the cyclic transmission of the thermostat's "Current Temperature" object
	[Off]	

Weight of temperatures during the day

Weight of internal temperature sensor

Weight of outside temperature 1

Weight of outside temperature 2

Weight of outside temperature 3

Weight of outside temperature 4

Weight of outside temperature 5

Weight of outside temperature 6

Weight of outside temperature 7

Weight of outside temperature 8

Weight of temperatures during the night

Weight of internal temperature sensor

Weight of outside temperature 1

Weight of outside temperature 2

Weight of outside temperature 3

Weight of outside temperature 4

Weight of outside temperature 5

Weight of outside temperature 6

Weight of outside temperature 7

Weight of outside temperature 8

Current Temperature

Send Cycle Time

Send Difference

Current temperature

Communication objects and ETS parameters

Setpoint

Setpoint parameters

ETS text	Values available [Default value]	Comment
Mode after bus return (come da immaginare a dx)	1 = Comfort	Thermostat operating mode at bus power on
	2 = Standby	
	3 = Energy saving	
	4 = Protected	
	255 = Last Mode Selected	
	[255]	
Default mode (On)	Comfort	Thermostat operating mode following power on request from button or bus.
	Standby	
	[Comfort]	
Default mode (Off)	Energy saving	Thermostat operating mode following power off request from button or bus.
	Protected	
	[Protection]	
Time between heating and cooling	1 min.	To avoid the formation of condensation with radiating systems during changes of season
	10 min.	
	15 min.	
	20 min.	
	25 min.	
	30 min.	
	45 min.	
	60 min.	
	[30]	
	Send cycle time	
1 min.		
2 min.		
3 min.		
4 min.		
5 min.		
10 min.		
15 min.		
20 min.		
25 min.		
30 min.		
[10 min]		
Send difference	Off	Sets the minimum temperature change made by the guest with respect to the setpoint that results in the current setpoint being sent over the bus towards a supervisor
	0.1 °C	
	0.2 °C	
	0.3 °C	
	0.4 °C	
	0.5 °C	
	0.6 °C	
	0.7 °C	
	0.8 °C	
	0.9 °C	
	1.0 °C	
[0.6 °C]		
Reset setpoint shift in energy saving	Yes	By selecting "Yes", when the thermostat goes into Energy Saving (Economy) mode, the setpoint set by the user in Comfort and Standby mode is reset to the design default value. This function is useful for hotel applications and with the supervision software
	No	
	[Yes]	

Continued

Mode after bus return last selected mode ▼

Default mode (ON) Comfort Standby

Default mode (OFF) Economy Protect

Time Between Heating and Cooling 30 min ▼

Current Setpoint

Send cycle time 10 min ▼

Send Difference 0,6 °C ▼

Reset Setpoint Shift in Economy Mode No Yes

Setpoint parameters

Important: The "Time between Heating and Cooling" parameter is the wait time it takes for the thermostat to switch from summer-winter and vice versa. This parameter is especially useful in some underfloor radiant systems where you set a high time value to prevent the formation of condensation; this applies especially when the thermostats work with a neutral zone and so there could be multiple seasonal changes in a single day. If instead, depending on the type of system, you want a faster response of the thermostat, it is necessary to reduce the value of this parameter.

Continued

ETS text	Values available [Default value]	Comment
Setpoint to send in neutral zone	Current setpoint	Possibility of choosing whether to send the current setpoint (the one the thermostat is using for control) or the setpoint shown (average of the heating and cooling setpoint). This Parameter is only available if the neutral zone is enabled in the "Thermostat settings" menu
	Average setpoint	
	[Current setpoint]	

Communication objects and ETS parameters

Temperature Setpoint

Setpoint parameters

ETS text	Values available [Default value]	Comment
Winter comfort setpoint	[20]	See "Range" table
Winter standby setpoint	[18]	See "Range" table
Winter energy saving setpoint	[15]	See "Range" table
Antifreeze	0 = Control Off	If you set "On" you can set the temperature the thermostat goes to in "Protected" mode; if you set "Off", when the thermostat is in "Protected" mode it will turn off temperature control
	1 = Control On	
	[1 = Control On]	
Antifreeze Setpoint	[5]	Yes See "Range" table. This parameter is available if the "Anti-freeze" parameter is "Control On"
Summer comfort setpoint	[25]	See "Range" table

Continued

Setpoint range

Temp. °C	Temp. °C	Temp. °C	Temp. °C
5	16	27	38
6	17	28	39
7	18	29	40
8	19	30	41
9	20	31	42
10	21	32	43
11	22	33	44
12	23	34	45
13	24	35	
14	25	36	
15	26	37	

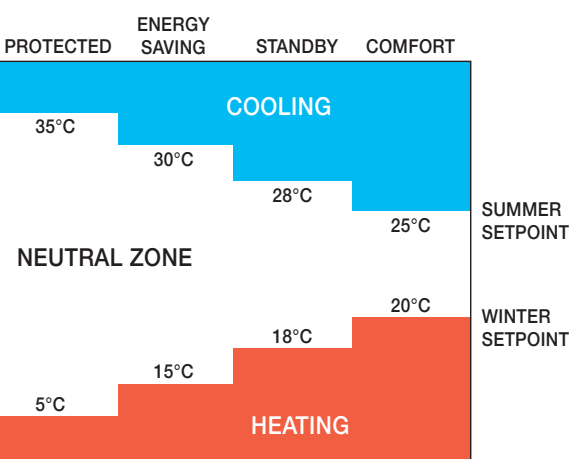

CAUTION: When the thermostat is in Neutral Zone mode, the breadth of this must be progressively increasing for the different operating modes of Comfort (minimum neutral zone operating breadth), Standby, Energy Saving and Protected. This setting made with ETS ensures that, when the thermostat changes operating mode, the active setpoint is always at a suitable value and the thermostat does not start cooling if it was heating before or vice versa, causing considerable energy consumption.

Continued

ETS text	Values available [Default value]	Comment
Summer standby setpoint	[28]	See "Range" table
Summer energy saving setpoint	[30]	See "Range" table
Too hot	0 = Control Off	If you set "On" you can set the temperature the thermostat goes to in "Protected" mode; if you set "Off", when the thermostat is in "Protected" mode it will turn off temperature control and will not send the current setpoint temperature
	1 = Control On	
	[1 = Control On]	
Setpoint too hot	[5]	Yes See "Range" table. This parameter is available if the "Too hot" parameter is "Control On"

Note: In the case of a 4-pipe system, the winter setpoint cannot take a higher value than the summer setpoint.

Winter

Setpoint Comfort Winter: 20 °C

Setpoint Standby Winter: 18 °C

Setpoint Economy Winter: 15 °C

Antifreeze: Regulation Off Regulation On

Setpoint Antifreeze: 5 °C

Summer

Setpoint Comfort Summer: 25 °C

Setpoint Standby Summer: 28 °C

Setpoint Economy Summer: 30 °C

Too hot: Regulation Off Regulation On

Setpoint Too Hot: 35 °C

Temperature setpoint parameters

Communication objects and ETS parameters

Window sensor

Sensor Parameters

ETS text	Values available [Default value]	Comment
Window sensor	Enable	To enable the window open signalling control function from the bus.
	Disable	
	[Disable]	
Window sensor delay	Off, 5 s, ..., 300 s	Sets the time delay that heating/air conditioning stops after window open detection
	[30 s]	

Window switch enable disable

Delay for window switches 30 sec ▼

Window sensor

Boiler shutdown

Boiler shutdown parameters

ETS text	Values available [Default value]	Comment
Boiler shutdown function	Enable	To enable the function
	Disable	
	[Disable]	
Boiler shutdown delay	Off, 5 s, ..., 300 s	To set the time delay that heating/air conditioning stops after boiler shutdown detection
	[Off=no delay]	
Reactivation time after boiler shutdown	Off, 1h, 2h, 4h, 8h	To set the time delay that heating/air conditioning restarts after the end of the boiler shutdown
	[Off=no delay]	

Boiler block function enable disable

Delay for boiler block off ▼

Reactivation time of boiler block off ▼

Boiler shutdown

Control parameters

ETS text	Values available [Default value]	Comment
Temperature control	0 = Control On/Off 1 = Integral band 2 = Proportional/Integral Band [0]	Set according to the type of control required for the heating/air conditioning system
Proportional cooling value	Off 1.0 °C 1.1 °C 1.2 °C 1.3 °C 1.4 °C 1.5 °C 1.6 °C 1.7 °C 1.8 °C 2.0 °C 2.2 °C 2.5 °C 3.0 °C 3.5 °C 4.0 °C 4.5 °C 5.0 °C [3.0 °C]	To be set according to the characteristics of the system and the room (consult a heating engineer)

Temperature Regulation Regulation On/Off ▼

Differential coefficient 0,2 °C ▼

ON/OFF control

Continued

Communication objects and ETS parameters

Continued

ETS text	Values available [Default value]	Comment
Integral cooling value	5 min.	
	6 min.	
	7 min.	
	8 min.	
	9 min.	
	10 min.	
	12 min.	
	15 min.	
	17 min.	
	20 min.	
	25 min.	
	30 min.	
	40 min.	
	50 min.	
	60 min.	
90 min.		
120 min.		
	[20 min.]	
Proportional heating value	1.0 °C	To be set according to the characteristics of the system and the room (consult a heating engineer)
	1.1 °C	
	1.2 °C	
	1.3 °C	
	1.4 °C	
	1.5 °C	
	1.6 °C	
	1.7 °C	
	1.8 °C	
	2.0 °C	
	2.2 °C	
	2.5 °C	
	3.0 °C	
	3.5 °C	
	4.0 °C	
4.5 °C		
5.0 °C		
	[3.0 °C]	
Integral heating value	5 min.	
	6 min.	
	7 min.	
	8 min.	
	9 min.	
	10 min.	
	12 min.	
	15 min.	
	17 min.	
	20 min.	
	25 min.	
	30 min.	
	40 min.	
	50 min.	
	60 min.	
90 min.		
120 min.		
	[20 min.]	
Differential coefficient	0.1 ... 1.0 °C	For On/Off type control: set the thermostat hysteresis that determines activation/deactivation of the system with reference to the difference between the setpoint and the measured temperature
	[0.2]	

Temperature Regulation	Integral Band ▾
Integral Value Cooling	20 min ▾
Integral Value Heating	20 min ▾

Integral band

Temperature Regulation	Proportional/Integral Band ▾
Proportional Value Cooling	3.0 °C ▾
Integral Value Cooling	20 min ▾
Proportional Value Heating	3.0 °C ▾
Integral Value Heating	20 min ▾

Proportional/integral band

Communication objects and ETS parameters

Proportional/Integral (PI) control

This type of control uses a more advanced algorithm that keeps the temperature inside the room more stable, increasing comfort. This algorithm works by switching the system on and off so as to be like a gradual increase or decrease in the system's thermal (or refrigerating) power. To obtain optimal performance you need to perform the calibration according to the type of room and heating system.

Define the variables:

- T_a = room temperature
- S_p = current setpoint
- K_p = coefficient of the proportional component
- K_i = coefficient of the integral component
- B_p = proportional band
- T_i = integrative time

the algorithm is characterised by the following parameters:

- **Proportional band:** used to calculate the coefficient $K_p = 100 / B_p$ and corresponds to the breadth of the proportional control band. Starting from the set temperature, this value is the temperature range in which the system power goes from 0% to 100%. *For example:* with the (heating) temperature set to 20.0°C and Band (P) =4.0°C, the thermostat runs the heating system at 100% when T_a is $\leq 16.0^\circ\text{C}$; as this temperature increases, the system power is consequently lowered down to 0% when T_a reaches 20°C. The value must be set taking account of the thermal capacity of the room to control; in general, it is recommended to use small values for rooms with a good level of thermal insulation and vice versa.
- **Integrative time:** used to calculate the coefficient $K_i = K_p / T_i$ and corresponds to the time passed which, when equal to the deviation from the setpoint (error), the integrative component generates a contribution equal to that generated by the proportional component. The integral contribution reduces the error on full operation if thermal energy is lost in the room to be controlled, as this contribution increases according to the time during which the setpoint is not reached. If this value is not set correctly, it can cause transients with variations around the setpoint or it may take longer to reach the setpoint.

Proportional integral PWM: PI control with On/Off valve

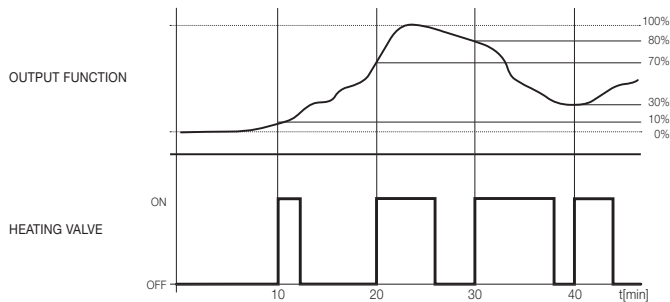

Continuous integral proportional: PI control with proportional valve

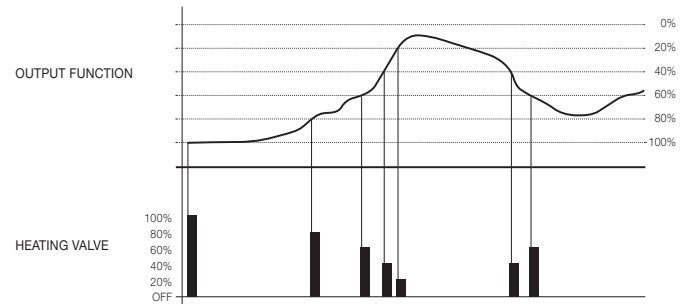

The parameters of the proportional and integral coefficients K_p and K_i are set using the ETS software: the proportional coefficient K_p for heating corresponds to the "Heating Proportional Value" parameter while the coefficient for cooling is set using the "Cooling Proportional Value" parameter. The integral time T_i is set with the "Heating Integral Value" and "Cooling Integral Value" parameters for heating and cooling, respectively.

The PI control parameters should be set according to the type of heating or cooling system used, the size of the room and its thermal insulation.

IMPORTANT: Generally, when using fan coils, PI control is not used. The valve is typically managed with On/Off control and On/Off valve or proportional valve (0%-100%); the fine adjustment is then made using the fan speed.

Communication objects and ETS parameters

Valve

Valve parameters

ETS text	Values available [Default value]	Comment
Type of system	2 pipes	Select according to the type of installed system
	4 pipes	
	6-way valve	
	[2 pipes]	
Send cycle time	Off, 30s, ..., 30min	Sets the cyclic transmission of the valve status only in the active season. In summer, the messages are not sent cyclically on the output for heating and vice versa.
	[Off]	
Valve type	Off	To choose the type of valve in a 2-pipe system
	ON/OFF	
	Proportional	
	[On/Off]	
Type of valve for cooling	Off	To choose the type of valve for cooling in a 4-pipe system
	ON/OFF	
	Proportional	
	[On/Off]	
Type of valve for heating	Off	To choose the type of valve for heating in a 4-pipe system
	ON/OFF	
	Proportional	
	On/Off]	

6-way valve

The 6-way valve is controlled proportionally with values of between 0% and 100%.

- 0%-33% for cooling (0% corresponds to the maximum cooling value)
- 33%-66% in neutral zone
- 0%-66% for heating (100% corresponds to the maximum heating value)

To use the 6-way valve, you need to

- Enable the "Neutral zone" parameter
- Select the "Temperature control" parameter as "Integral band" or "Proportional/integral band"

Installation of 2-pipe fan coil solenoid valve

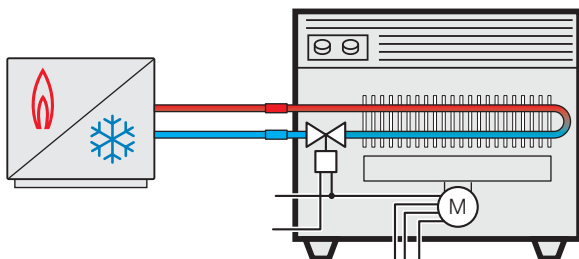

Plant Topology: 2 Tubes

Valve Type: On/Off

Send Cycle Time: off

2-pipe circuit On/Off

Plant Topology: 2 Tubes

Valve Type: Proportional

Send Cycle Time: off

2-pipe circuit Proportional

Plant Topology: 4 Tubes

Cooling Valve

Valve Type Cool: On/Off

Send Cycle Time: off

Heating Valve

Valve Type Heat: On/Off

Send Cycle Time: off

4-pipe circuit On/Off

Plant Topology: 4 Tubes

Cooling Valve

Valve Type Cool: Proportional

Send Cycle Time: off

Heating Valve

Valve Type Heat: Proportional

Send Cycle Time: off

4-pipe circuit Proportional

Plant Topology: 6-way valve

Send Cycle Time: off

6-way valve

Installation of 4-pipe fan coil solenoid valve

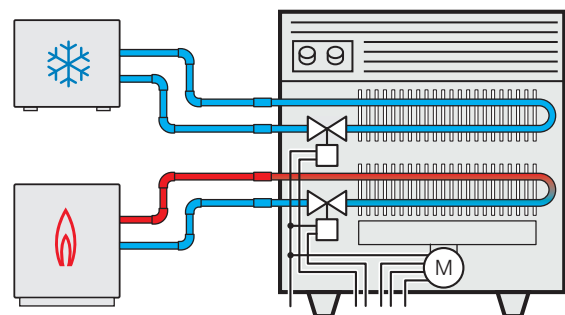

Communication objects and ETS parameters

2nd Heating/Cooling stage "Boost"

The second stage is used to control a second heating or cooling source that allows the "boost" function. The "boost" function enables the second auxiliary source (controlling the valve, the fans or both) when the current temperature differs from the current setpoint by more than the set threshold.

In this way, the main heating/cooling stage is assisted by the auxiliary source to reach the desired setpoint value faster.

This feature is particularly useful for improving comfort in dynamic lens systems such as underfloor systems.

The 2nd stage can also be used for mid season (where enabled) to exchange the primary stage with the 2nd stage.

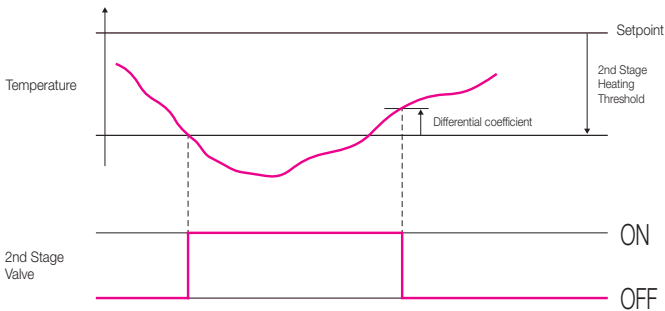

Heating 2nd stage disabled ▾

Cooling 2nd stage disabled ▾

2nd Stage Disabled

Heating 2nd stage enable 2 points control ON-OFF ▾

Threshold Heating 2,0 °C ▾

Cooling 2nd stage enable 2 points control ON-OFF ▾

Threshold Cooling 3,0 °C ▾

2nd Stage - Enable 2-point On-Off Control

Heating 2nd stage enable 2 points control 0%-100% ▾

Threshold Heating 3,0 °C ▾

Cooling 2nd stage enable 2 points control 0%-100% ▾

Threshold Cooling 3,0 °C ▾

2nd Stage - Enable 2-Point Control 0-100%

2nd Stage Parameters

ETS text	Values available [Default value]	Comment
2 nd Stage Cooling Valve	Off	Second Cooling stage off
	Enable 2-point On-Off Control	Control with object that sends on/off for valve status
	Enable 2-point 0-100% Control	Control with object that sends 0% for valve off status and 100% for valve on status
	[Off]	
Cooling Threshold	- 0.5°C - 1.0°C - 1.5°C - 2.0°C - 2.5°C - 3.0°C - 3.5°C - 4.0°C - 4.5°C - 5.0°C	Value of the trigger threshold in cooling mode (used by both the valve and the fan)
	[0.5°C]	
2 nd Stage Heating Valve	Off	Second heating stage off.
	Enable 2-point On-Off Control	Control with object that sends on/off for valve status
	Enable 2-point 0-100% Control	Control with object that sends 0% for valve off status and 100% for valve on status

Continued

Continued

ETS text	Values available [Default value]	Comment
Heating Threshold	- 0.5°C - 1.0°C - 1.5°C - 2.0°C - 2.5°C - 3.0°C - 3.5°C - 4.0°C - 4.5°C - 5.0°C	Value of the trigger threshold in heating mode (used by both the valve and the fan)
	[0.5°C]	

Communication objects and ETS parameters

Fans

The device envisages the possibility of enabling up to 4 configurable outputs which can be used, respectively, for: heating, cooling, 2nd stage heating and 2nd stage cooling.

The outputs for heating are available if the "Thermostat function" parameter is "Heating" or "Heating + Cooling".

The outputs for cooling are available if the "Thermostat function" parameter is "Cooling" or "Heating + Cooling".

For each output, you can choose the type of control and the related parameters.

Fan Type (1st stage)

off ▾

off ✓

Three speed fan coil

Proportional (0-100%)

Integration (Split and VRV)

Output type selection

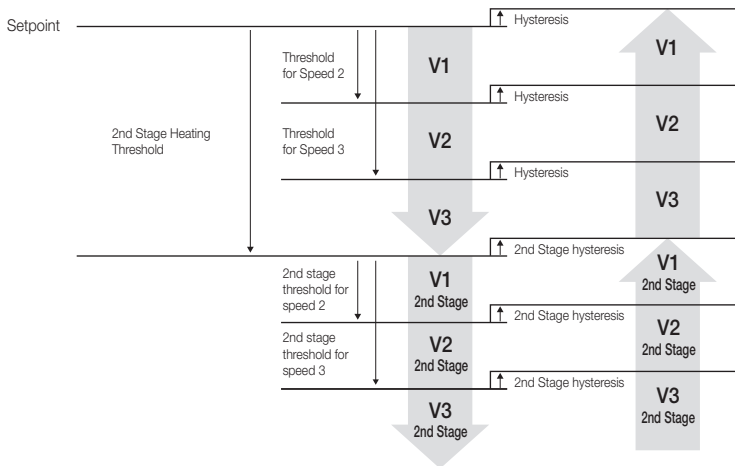

Output type selection

ETS text	Values available [Default value]	Comment
Type	Off	No thermostat controlled fan coil. Useful when controlling only the solenoid valve for a radiator system
	Three Speed Fan coil	Fan coil with 3 speeds
	Proportional (0 - 100%)	Proportional-speed fan coil
	Integration (split and VRV)	Integration with VRV systems
	[Three speed fan coil]	

Communication objects and ETS parameters

Three Speed Fan coil

ETS text	Values available [Default value]	Comment
Maximum fan speed	0	Sets maximum fan coil speed. Set "0" to control only the solenoid valve for a radiator system
	1	
	2	
	3	
	[3]	
Threshold value for fan speed 2	0.2 °C	Sets the difference between the current temperature and the setpoint that triggers start of speed V-2
	0.3 °C	
	0.5 °C	
	1.0 °C	
	1.5 °C	
	2.0 °C	
	2.5 °C	
	3.0 °C	
	3.5 °C	
	4.0 °C	
[1.0]		
Threshold value for fan speed 3	0.2 °C	Sets the difference between the current temperature and the setpoint that triggers start of speed V-3. For correct operation, the threshold for speed 3 must be greater than the threshold for speed 2.
	0.3 °C	
	0.5 °C	
	1.0 °C	
	1.5 °C	
	2.0 °C	
	2.5 °C	
	3.0 °C	
	3.5 °C	
	4.0 °C	
[2.0]		
Fan speed hysteresis	0.1 °C	Hysteresis for the above-mentioned speed values
	0.2 °C	
	0.3 °C	
	0.4 °C	
	0.5 °C	
	0.6 °C	
	0.7 °C	
	0.8 °C	
	0.9 °C	
	1.0 °C	
[1=0.1]		
Automatic/Manual fan mode value inversion	0 = manual, 1 = auto	To decide which value sent or received over the Bus indicates manual and which indicates automatic.
	1 = manual, 0 = auto	
	[0 = manual, 1 = auto]	
Switching time between speeds (min)	0...255	Time, in minutes, it takes to switch from one speed to another. To turn off the valves, please refer to the "Fan power-off delay" parameter
	[2]	
Time in manual fan mode	0...255	Duration of "Manual Forcing" for the fan speed if the guest has forced the speed; after this time the thermostat returns to automatic mode. If the parameter is set to "0" it is interpreted as "Time = infinite" and the fan speed, set manually, stays on. To restore automatic operation the guest must return the fan speed to AUTO by manually operating on the thermostat display.
	[0]	

Continued

Fan Type (1st stage) Three speed fan coil

Maximum Fan Speed (1st stage) 3

Threshold value for fan speed 2 (1st stage) 1,0 °C

Threshold value for fan speed 3 (1st stage) 2,0 °C

Hysteresis of fan speed (1st stage) 0,1 °C

Automatic/Manual fan mode value inversion (1st stage) 0 = manual, 1 = auto 0 = auto, 1 = manual

Time for switching between speeds (1st stage) 0 min

Time in manual fan mode (1st stage) 0 min

Delay for fan off (1st stage) 0 min

Objects (1st stage) 1 Bit object 8-Bit Object (1-100%)

Send Cycle Time (1st stage) off

Fans independent of the valve (1st stage) No Yes

Automatic fan disabling (1st stage) No Yes

Fan zero speed disabling (1st stage) No Yes

Three Speed Fan coil

Continued

ETS text	Values available [Default value]	Comment
Fan power-off delay (min)	0...255	Delay, expressed in minutes, to turn off the valves after receiving the off control.
	[2]	
Objects	0 = 1-Bit - On/Off	Select type of object (1 bit for On/Off, 8 bits for proportional 1-100%)
	1 = 8-Bit - Proportional (1-100%)	
Send cycle time	Off, 30s, ..., 30min	Sets possible cyclic transmission over the bus for the fans in the active season. In summer, the messages are not sent cyclically on the output for heating and vice versa.
	[Off]	
Fans independent of the valve	Yes	Possibility of controlling the fans even with the valve off
	No	
Automatic speed disabling	Yes	Possibility of disabling the fan button on the display and Fan coil objects: Automatic/Manual
	No	
Fan speed 0 disabling	Yes	Allows you to inhibit the possibility of turning off the fan. Speed 1 remains powered.
	No	
	[No]	

Communication objects and ETS parameters

Proportional (0- 100%)

ETS text	Values available [Default value]	Comment
Temperature at 100%	2 °C	Absolute difference between setpoint and current temperature above which the speed goes to 100%
	3 °C	
	4 °C	
	5 °C	
	[2 °C]	
Minimum fan speed	10%	Minimum operating speed on fan activation
	20%	
	30%	
	40%	
	50%	
	[10%]	
Automatic/Manual fan mode value inversion	0 = manual, 1 = auto	To decide which value sent or received over the Bus indicates manual and which indicates automatic.
	1 = manual, 0 = auto	
	[0 = manual, 1 = auto]	
Time in manual fan mode	0...255	Duration of "Manual Forcing" for the fan speed if the guest has forced the speed; after this time the thermostat returns to automatic mode. If the parameter is set to "0" it is interpreted as "Time = infinite" and the fan speed, set manually, stays on. To restore automatic operation the guest must return the fan speed to AUTO by manually operating on the thermostat display.
	[0]	
Fan power-off delay	0...255	Delay, expressed in minutes, to turn off the valves after receiving the off control. Parameter not available if "Fan speed 0 disabling" is set to "Yes".
	[2]	
Send cycle time	Off, 30s, ..., 30min	Sets possible cyclic transmission over the bus for the fans in the active season. In summer, the messages are not sent cyclically on the output for heating and vice versa.
	[Off]	
Fans independent of the valve	Yes	Possibility of controlling the fans even with the valve off
	No	
	[No]	
Automatic speed disabling	Yes	Possibility of disabling the fan button on the display and Fan coil objects: Automatic/Manual
	No	
	[No]	
Fan speed 0 disabling	Yes	Allows you to inhibit the possibility of turning off the fan. Speed 1 remains powered. The fan is powered off in any case when the thermostat is in the opposite season with respect to the function performed by the fan.
	No	
	[No]	

Fan Type (1st stage) Proportional (0-100%)

Temperature for 100% (1st stage) 2°C

Minimum Fan Speed (1st stage) 10%

Automatic/Manual fan mode value inversion (1st stage) 0 = manual, 1 = auto 0 = auto, 1 = manual

Time in manual fan mode (1st stage) 0 min

Delay for fan off (1st stage) 0 min

Send Cycle Time (1st stage) off

Fans independent of the valve (1st stage) No Yes

Automatic fan disabling (1st stage) No Yes

Fan zero speed disabling (1st stage) No Yes

Proportional 0- 100%

Communication objects and ETS parameters

Split/VRV integration

The 4 outputs for the thermostat fans (heating, cooling, 2nd heating stage, 2nd cooling stage) can be used to liaise with split/VRV interfaces. For each output, using the "Split/VRV controlled by the thermostat" parameter, you can decide whether the temperature control logic is performed by the thermostat or whether the management is handled entirely by the split/VRV interface. If the "Split/VRV controlled by the thermostat" parameter is set to "Yes", the thermostat enables the output of the current season and controls the split/VRV interface, checking the current temperature and setpoint. If "Split/VRV controlled by the thermostat" is set to "No", the multisensor display is used as the remote control for the split/VRV with the possibility of modifying the setpoint, the speed of the fans (auto, V1, V2,...) and the operating mode (AUTO, HEAT, COOL, FAN, DRY).

"Split/VRV controlled by the thermostat" parameter enabled

Function	Setting
<i>Messages sent automatically by the thermostat according to the control logic decided by the thermostat itself depending on its setpoint and on the current temperature</i>	
Valve control	The thermostat makes the controls available for the hot and cold valves (objects 50, 51, 53, 54). The objects can be connected to the "Heat Mode" and "Cool Mode" inputs of the split/VRV interface. This way, when according to the thermostat control logic, you need to heat or cool, the split/VRV interface can receive the enabling on the object for Heat mode (heating) or Cool (cooling) mode.
Fan control	The thermostat can control the 4 fan outputs according to the control logic, exploiting the objects available in the 3 "Fan management modes" for the split/VRV interface: Scaling, Enum, Bits. The object "Fan coil: Automatic/Manual" of the VRV (83, 114, 145, 176) is always set to "Manual".
Control on towards the VRV machine	The thermostat makes 2 objects available, which can be used to turn the split/VRV interface on and off: <ul style="list-style-type: none"> object 13 which signals when the thermostat is in an ON mode or in an OFF mode object On/Off present in each of the 4 outputs (75, 106, 137, 168) which is active if the output season is active (e.g. in winter objects 75 and 137 are active)
Mode transmission	The thermostat makes a type DPT_20.105 object available for each of the 4 outputs (objects 86, 117, 148, 179) with the values chosen for the modes enabled for thermostat heating or cooling respectively according to the thermostat control logic. Caution: if the user changes the split/VRV mode (HEAT and FAN for heating, COOL, DRY and FAN for cooling) from the remote control, the thermostat could receive feedback with a mode (objects 85, 116, 147, 178) that does not correspond to the mode the thermostat deems active according to its control logic. If this is the case, it will overwrite the operating mode. For instance: if it receives the FAN mode (enabled among the valid modes) for heating, it accepts this new mode; if it receives COOL, DRY or AUTO, it overwrites it, and if it receives other modes it does not perform any operation.

Function	Setting
Manual/automatic control	The thermostat makes a 1 bit object available for each of the 4 outputs (objects 83, 114, 145, 176) to control the split/VRV interface in manual or automatic mode. With "Split/VRV controlled by the thermostat" enabled, the thermostat sends a "manual" control to the VRV interface.
<p>Note 1: the outputs are independent and controlled by the thermostat according to its logic. When performing its logics, the thermostat, switching from heating to cooling or vice-versa, will turn off the previously activated output(s) and turn on the necessary output(s).</p> <p>Note 2: If the "machine" for heating is the same as the one for cooling, the thermostat output controls must be connected to the same group addresses.</p> <p>Note 3: The thermostat controls the outputs (both valves and fans) utilising the "Cyclic transmission" parameter only for the current season. The inactive season already has the fans and valves turned off; repeating the message might be a problem when the cooling machine is the same as the heating machine and therefore has the same address.</p>	
<i>Selection from User interface for the main heating and cooling outputs</i>	
Fan speed selection	From a button 32144 configured as trigger control/push button, you can select the speed of the split/VRV interface: V0, V1, V2... or you can select the thermostat to work automatically (AUTO). The thermostat makes objects 79, 110, 141, 172 available to connect to the climate control trigger message to perform cycles between the speeds (V0, V1, V2, ...) and AUTO. By selecting a speed V0, V1, V2... the thermostat is set to manual operation for the time determined by the "Time in manual fan mode" parameter.
ON/OFF selection	By choosing ON/OFF from the thermostat UI, you turn the thermostat "ON/OFF", in other words the thermostat changes its operating mode but there is no direct intervention on the split/VRV interface
Split/VRV interface ON/OFF	From an external button configured to send ON/OFF controls, you can turn the split/VRV interface on and off. The thermostat makes objects 76, 107, 138, 169 available to connect to the ON/OFF message of the external button. Caution: if the user turns off the split/VRV interface from the remote control or external button, the thermostat may force the power-on of the split/VRV interface (objects 85, 116, 147, 178) according to its control logic.
Thermostat mode selection	From a button 32144 configured as trigger control/push button, you can select the thermostat modes (comfort, standby, energy saving and protected). The thermostat makes the climate control trigger object 29 available
Split/VRV interface mode selection	From a button 32144 configured as trigger control/push button, you can choose the split/VRV interface modes that have been enabled from the parameter (HEAT, COOL, DRY, FAN). The thermostat makes objects 81, 112, 143, 174 available to connect to the climate control trigger message.
Setpoint change	From the user interface, you can change the setpoint and send it to object 30 to communicate it to the split/VRV interface.

Communication objects and ETS parameters

“Split/VRV controlled by the thermostat” parameter disabled

Function	Setting
<i>Messages sent automatically by the thermostat according to the control logic decided by the thermostat itself depending on its setpoint and on the current temperature</i>	
Valve control	Same behaviour as the case with parameter enabled
Fan control	The thermostat does not automatically send messages for the fan control of the split/VRV interface.
Control on towards the VRV machine	The thermostat does not automatically send messages for the ON/OFF control of the split/VRV interface on objects 75, 106, 137, 168. Object 13 remains however available, which signals when the thermostat is in an ON mode or in an OFF mode
Mode transmission	The thermostat does not automatically send messages with the operating mode to the split/VRV interface. The messages received on objects 85, 116, 147, 178 are repeated on objects 86, 117, 148, 179 only if the mode is among those enabled from parameters.
Manual/automatic control	The thermostat makes a 1 bit object available for each of the 4 outputs (83, 114, 145, 176) to control the interface in manual or automatic mode. With “Split/VRV controlled by the thermostat” disabled, the thermostat normally sends an “automatic” control to the VRV interface.
<i>Selection from User interface for the main heating and cooling outputs</i>	
Fan speed selection	From a button 32144 configured as trigger control/push button, you can select the speed of the split/VRV interface: V0, V1, V2... or you can select the thermostat to work automatically (AUTO). The thermostat makes objects 79, 110, 141, 172 available to connect to the climate control trigger message to perform cycles between the speeds (V0, V1, V2, ...) and AUTO. By selecting a speed V0, V1, V2... the thermostat is set to manual operation for the time determined by the “Time in manual fan mode” parameter. The other input objects dedicated to the split/VRV interface are only accepted if the split/VRV interface is in “manual” operation. What’s more, with the trigger control, the split/VRV interface can be in “manual” operation after receiving the dedicated control on object “Fan coil: Automatic/Manual” (82, 113, 144, 175).
ON/OFF selection	Same behaviour as the case with parameter enabled
Split/VRV interface ON/OFF	From an external button configured to send ON/OFF controls, you can turn the split/VRV interface on and off. The thermostat makes objects 76, 107, 138, 169 available to connect to the ON/OFF message of the external button.
Thermostat mode selection	Same behaviour as the case with parameter enabled
Split/VRV interface mode selection	Same behaviour as the case with parameter enabled
Setpoint change	Same behaviour as the case with parameter enabled

ETS text	Values available [Default value]	Comment
Heating mode	Enable	To make the “Heating mode” available among the possible modes to call up on the thermostat display. Parameter not available if “Split/VRV controlled by the thermostat” is set to “No”.
	Disable	
	[Disable]	
Fan mode	Enable	To make the “Fan mode” available among the possible modes to call up on the thermostat display. Parameter not available if “Split/VRV controlled by the thermostat” is set to “No”.
	Disable	
	[Enable]	
Cooling mode	Enable	To make the “Cooling mode” available among the possible modes to call up on the thermostat display. Parameter not available if “Split/VRV controlled by the thermostat” is set to “No”.
	Disable	
	[Disable]	
Dehumidification mode	Enable	To make the “Dehumidification mode” available among the possible modes to call up on the thermostat display. Parameter not available if “Split/VRV controlled by the thermostat” is set to “No”.
	Disable	
	[Enable]	
Split/VRV controlled by the thermostat	Yes	To decide whether the temperature control logic is performed by the thermostat or is handled completely by the VRV system. In this latter case, the thermostat simply turns on the VRV system and can be used as a remote control for the VRV system.
	No	
	[Yes]	
Automatic/Manual fan mode value inversion	0 = manual, 1 = auto	To decide which value sent or received over the Bus indicates manual and which indicates automatic.
	1 = manual, 0 = auto	
	[0 = manual, 1 = auto]	
Fan management mode	Disabled	
	Scaling	
	Enum	
	Bits	
	[Disabled]	
Fan speed number	2	
	3	
	4	
	5	
	[3]	
Fan speed 2 threshold	0.2 °C	Sets the difference between the current temperature and the setpoint that triggers start of speed V-2. Parameter not available if “Split/VRV controlled by the thermostat” is set to “No”.
	0.3 °C	
	0.5 °C	
	1.0 °C	
	1.5 °C	
	2.0 °C	
	2.5 °C	
	3.0 °C	
	3.5 °C	
	4.0 °C	
[1.0]		

Continued

Communication objects and ETS parameters

Continued

ETS text	Values available [Default value]	Comment
Fan speed 3 threshold	0.2 °C	Sets the difference between the current temperature and the setpoint that triggers start of speed V-3. Parameter not available if "Split/VRV controlled by the thermostat" is set to "No". For correct operation, the threshold for speed 3 must be greater than the threshold for speed 2.
	0.3 °C	
	0.5 °C	
	1.0 °C	
	1.5 °C	
	2.0 °C	
	2.5 °C	
	3.0 °C	
	3.5 °C	
	4.0 °C	
	[2.0]	
Fan speed 4 threshold	0.2 °C	Sets the difference between the current temperature and the setpoint that triggers start of speed V-4. Parameter not available if "Split/VRV controlled by the thermostat" is set to "No". For correct operation, the threshold for speed 4 must be greater than the threshold for speed 3.
	0.3 °C	
	0.5 °C	
	1.0 °C	
	1.5 °C	
	2.0 °C	
	2.5 °C	
	3.0 °C	
	3.5 °C	
	4.0 °C	
	[3.0]	
Fan speed 5 threshold	0.2 °C	Sets the difference between the current temperature and the setpoint that triggers start of speed V-5. Parameter not available if "Split/VRV controlled by the thermostat" is set to "No". For correct operation, the threshold for speed 5 must be greater than the threshold for speed 4.
	0.3 °C	
	0.5 °C	
	1.0 °C	
	1.5 °C	
	2.0 °C	
	2.5 °C	
	3.0 °C	
	3.5 °C	
	4.0 °C	
	[4.0]	

Fan Type (1st stage) Integration (Split and VRV) ▼

Heating mode enable disable

Fan mode enable disable

Split/VRV controlled by thermostat (1st stage) No Yes

Automatic/Manual fan mode value inversion (1st stage) 0 = manual, 1 = auto 0 = auto, 1 = manual

Fan management mode (1st stage) Scaling ▼

Fan speed number (1st stage) 3 ▼

Fan speed 1 threshold (1st stage) 33% ▼

Fan speed 2 threshold (1st stage) 67% ▼

Fan speed 3 threshold (1st stage) 100% ▼

Fan speed 4 threshold (1st stage) 100% ▼

Threshold value for fan speed 2 (1st stage) 1,0 °C ▼

Threshold value for fan speed 3 (1st stage) 2,0 °C ▼

Threshold value for fan speed 4 (1st stage) 3,0 °C ▼

Threshold value for fan speed 5 (1st stage) 4,0 °C ▼

Hysteresis of fan speed (1st stage) 1,0 °C ▼

Time in manual fan mode (1st stage) 0 min ▼

Send Cycle Time (1st stage) off ▼

Fans independent of the valve (1st stage) No Yes

Fan zero speed disabling (1st stage) No Yes

Integration (split/VRV) – Scaling case

If Fan management mode= Scaling:

ETS text	Values available [Default value]	Comment
Scaling: Fan speed 1 Threshold	0...100% [33%]	Minimum value sent for fan control.
Scaling: Fan speed 2 Threshold	0...100% [67%]	Value sent in the event that the current temperature and the setpoint differ by a value more than "Fan speed 2 threshold"
Scaling: Fan speed 3 Threshold	0...100% [100%]	Value sent in the event that the current temperature and the setpoint differ by a value more than "Threshold value for fan speed 3"
Scaling: Fan speed 4 Threshold	0...100% [100%]	Value sent in the event that the current temperature and the setpoint differ by a value more than "Threshold value for fan speed 4"

Note: in the event that the difference between the current temperature and the setpoint differs by a value more than "Threshold value for fan speed 5", the value of 100% is sent.

Communication objects and ETS parameters

If Fan management mode= Enum:

ETS text	Values available [Default value]	Comment
Enum: Fan speed 1 value	1...255 [1]	Minimum value sent for fan control.
Enum: Fan speed 2 value	1...255 [2]	Value sent in the event that the current temperature and the setpoint differ by a value more than "Threshold value for fan speed 2"
Enum: Fan speed 3 value	1...255 [3]	Value sent in the event that the current temperature and the setpoint differ by a value more than "Threshold value for fan speed 3"
Enum: Fan speed 4 value	1...255 [4]	Value sent in the event that the current temperature and the setpoint differ by a value more than "Threshold value for fan speed 4"
Enum: Fan speed 5 value	1...255 [5]	Value sent in the event that the current temperature and the setpoint differ by a value more than "Threshold value for fan speed 5"

For all the Fan management mode values:

ETS text	Values available [Default value]	Comment
Fan speed hysteresis	0.1 °C	Hysteresis for the above-mentioned speed values. Parameter not available if "Split/VRV controlled by the thermostat" is set to "No".
	0.2 °C	
	0.3 °C	
	0.4 °C	
	0.5 °C	
	0.6 °C	
	0.7 °C	
	0.8 °C	
	0.9 °C	
	1.0 °C	
	[0.1]	
Time in manual fan mode	0...255	Duration of "Manual Forcing" for the fan speed if the guest has forced the speed; after this time the thermostat returns to automatic mode. If the parameter is set to "0" it is interpreted as "Time = infinite" and the fan speed, set manually, stays on. To restore automatic operation the guest must return the fan speed to AUTO by manually operating on the thermostat display. Parameter not available if "Split/VRV controlled by the thermostat" is set to "No".
	[0]	
Send cycle time	Off, 30s, ..., 30min	Sets possible cyclic transmission over the bus for the fans in the active season. In summer, the messages are not sent cyclically on the output for heating and vice versa.
	[Off]	
Fans independent of the valve	Yes	Possibility of controlling the fans even with the valve off
	No	
	[No]	

Continued

Continued

ETS text	Values available [Default value]	Comment
Fan speed 0 disabling	Yes	Allows you to inhibit the possibility of turning off the fan. Speed 1 remains powered.
	No	
	[No]	

Fan Type (1st stage) Integration (Split and VRV) ▾

Heating mode enable disable

Fan mode enable disable

Split/VRV controlled by thermostat (1st stage) No Yes

Automatic/Manual fan mode value inversion (1st stage) 0 = manual, 1 = auto 0 = auto, 1 = manual

Fan management mode (1st stage) Enum ▾

Fan speed number (1st stage) 3 ▾

Fan speed 1 value (1st stage) 1 ▾

Fan speed 2 value (1st stage) 2 ▾

Fan speed 3 value (1st stage) 3 ▾

Fan speed 4 value (1st stage) 4 ▾

Fan speed 5 value (1st stage) 5 ▾

Threshold value for fan speed 2 (1st stage) 1.0 °C ▾

Threshold value for fan speed 3 (1st stage) 2.0 °C ▾

Threshold value for fan speed 4 (1st stage) 3.0 °C ▾

Threshold value for fan speed 5 (1st stage) 4.0 °C ▾

Hysteresis of fan speed (1st stage) 1.0 °C ▾

Time in manual fan mode (1st stage) 0 min ▾

Send Cycle Time (1st stage) off ▾

Fans independent of the valve (1st stage) No Yes

Fan zero speed disabling (1st stage) No Yes

Integration (split/VRV) – Enum

Fan Type (1st stage) Integration (Split and VRV) ▾

Heating mode enable disable

Fan mode enable disable

Split/VRV controlled by thermostat (1st stage) No Yes

Automatic/Manual fan mode value inversion (1st stage) 0 = manual, 1 = auto 0 = auto, 1 = manual

Fan management mode (1st stage) Bits ▾

Fan speed number (1st stage) 3 ▾

Threshold value for fan speed 2 (1st stage) 1.0 °C ▾

Threshold value for fan speed 3 (1st stage) 2.0 °C ▾

Threshold value for fan speed 4 (1st stage) 3.0 °C ▾

Threshold value for fan speed 5 (1st stage) 4.0 °C ▾

Hysteresis of fan speed (1st stage) 1.0 °C ▾

Time in manual fan mode (1st stage) 0 min ▾

Send Cycle Time (1st stage) off ▾

Fans independent of the valve (1st stage) No Yes

Fan zero speed disabling (1st stage) No Yes

Integration (split/VRV) - Bits

Communication objects and ETS parameters

Manual operation of the fans

The user selects the speed used by the thermostat only when the valve is on; if the valve is off at the time of selection, the thermostat saves the setting and uses it again the next time the valve is on. On the display, the fan speed changes from "AUTO" to "OFF".

The selection made by the user remains active until the end of the time (in minutes) set by the "Time in Manual Fan Mode (min)" parameter or the fan speed is set manually onto "AUTO" with an external button that communicates with the "Fan trigger" object present in each output.

The "Fan input" objects for speeds 1, 2, 3 are managed this way. Upon receipt of a 1 bit, the speed is activated and turns off the one that was on, if any. Upon receipt of a 0 bit on an active speed, the speed is turned off (sending a 1 bit on "Speed Off" and a 0 bit on the current speed) only if the "Fan speed 0 disabling" parameter is set to "No".

Caution: If the "Time in Manual Fan Mode (min)" parameter is equal to 0 it means that the manual operation of the fan is never turned off by time.

Automatic three-speed fan coil operation

In the case of a three-speed fan coil in "AUTO" mode, the fan coil speed is controlled automatically by the thermostat. The speed automatically goes from the higher to the lower speed gradually as the measured temperature approaches the value set as the setpoint. The threshold to determine the speed to set is linked to the following parameters: "Threshold for the Speed of Fan 2" and "Threshold for the Speed of Fan 3" while speed 1 is active when the valve is turned on and the "Switching time between speeds (min)" has passed.

An example of operation is shown in the following figure where SV2 and SV3 are respectively "Threshold for the Speed of Fan 2" and "Threshold for the Speed of Fan 3"; ΔT_R is instead the "Differential Coefficient" of the on/off setting.

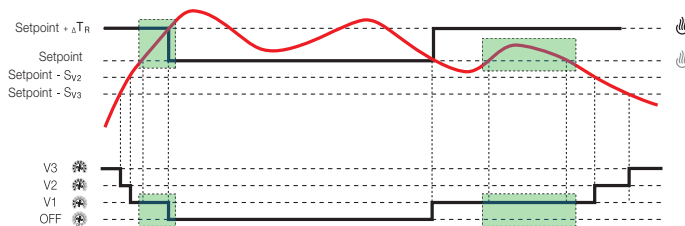
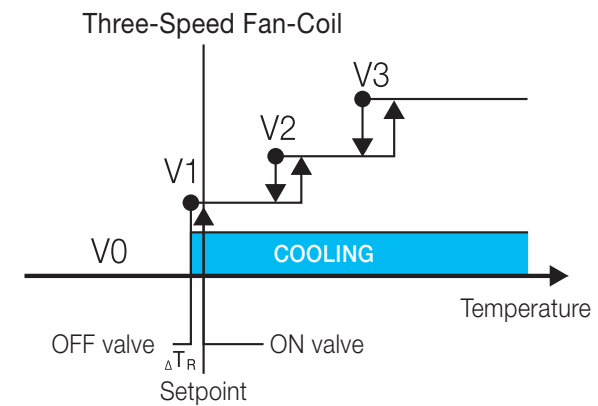
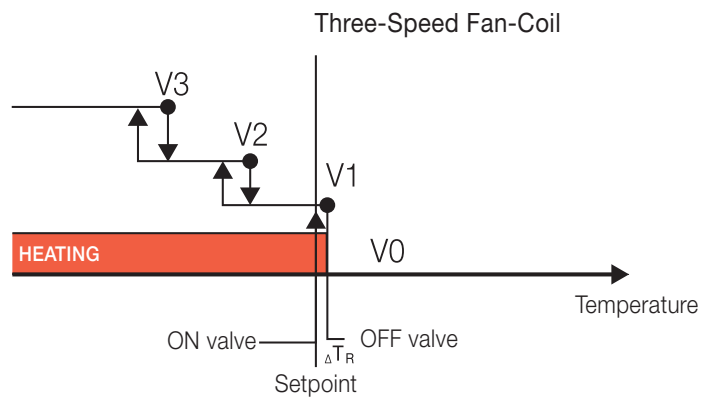

Note: In the example shown in the figure, the effect of the "Fan Speed Hysteresis" parameter was overlooked and the "Switching time between speeds" parameter was set = 0.

When the measured temperature reaches the setpoint the thermostat switches off the fan, sends a 1 bit on the Bus for object "Speed Off", switches on V0 and switches off V1. When the temperature deviates from the desired value, the valve is turned on and the speed V1, after the value of "Switching time between speeds", is activated. In the following example figures, this parameter is set to 0.

N.B.: For reasons tied to the safety of systems, if the valve is active the user will be unable to set "OFF" from the thermostat. It will therefore be necessary to turn off the valve by setting the thermostat to another mode or by modifying its setpoint.

Switching Time Between Speeds

This is the time you need to wait for the activation of the speed after switching on the valve (allows the fan coil battery to reach the correct temperature before circulating the air). This parameter is also used between one speed change and another to avoid continual speed switching near the thresholds.

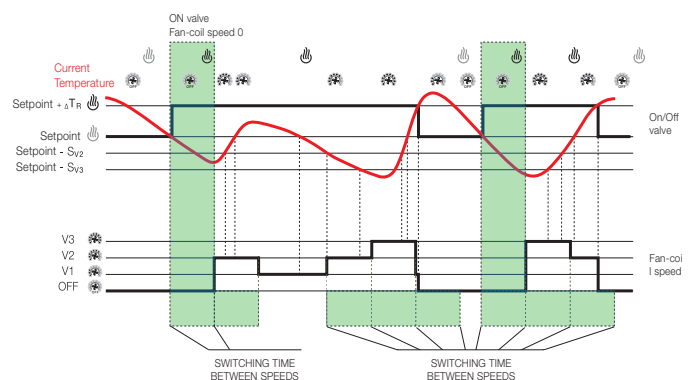

Communication objects and ETS parameters

Proportional fan coil operation

Proportional fan operation is similar to that of the three-speed fan coil. When the valve is OFF the proportional speed is equal to 0%; when the valve is ON the value of the proportional speed depends on the difference between the setpoint and the temperature measured in the room. The greater the difference, the higher the set proportional value of the speed. When this difference exceeds the value of the "Threshold for Speed at 100%" the proportional output of the fan is set to the highest possible speed that is 100%; when the difference is minimal the proportional speed is set to "Minimum Fan Speed". The operation of the proportional fan, as for the three speeds, can be set automatically or, in manual mode, to the value invoked by the thermostat button or set by the object "Proportional (0-100%) - Fan Inputs"

Proportional Fan Coil

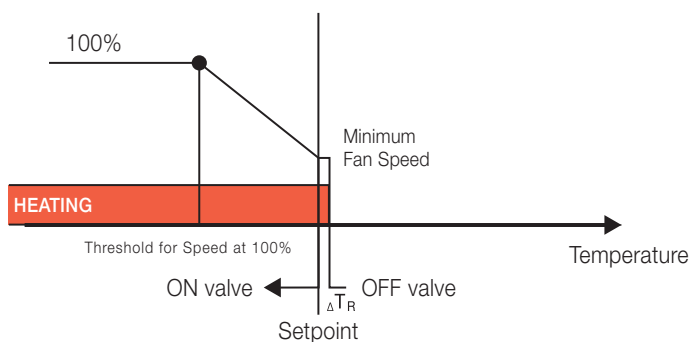

Proportional Fan Coil

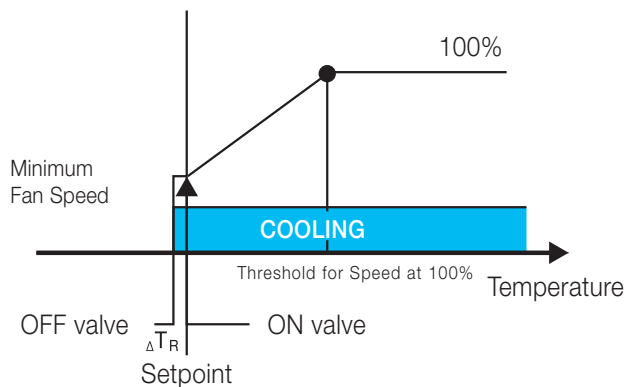

N.B.: For reasons tied to the safety of systems, if the valve is active the user will be unable to set "OFF" from the thermostat. It will therefore be necessary to turn off the valve by setting the thermostat to another mode or by modifying its setpoint.

Communication objects and ETS parameters

Scenario

16 scenarios are available. 16 different scenarios that call up the operating modes can therefore be saved and with **Enable Scenario Learning** you can also set the operating mode for the desired scenario with a message from the bus (scene learn).

Scenario Parameters

ETS text	Values available [Default value]	Comment
Scene learning	Disable Enable [Enable]	To enable scenario thermostat learning
Scenario 1, ..., Scenario 16	Off Comfort Standby Energy saving Protected [Off]	To define the operating mode when the scenario is called up.

Scene learning

disable enable

Scene 1	disabled
Scene 2	disabled
Scene 3	disabled
Scene 4	disabled
Scene 5	disabled
Scene 6	disabled
Scene 7	disabled
Scene 8	disabled
Scene 9	disabled
Scene 10	disabled
Scene 11	disabled
Scene 12	disabled
Scene 13	disabled
Scene 14	disabled
Scene 15	disabled
Scene 16	disabled

Scenario parameters

Communication objects and ETS parameters

Temperature Protection

This function is used to limit the temperature of the area controlled by the thermostat

Temperature Protection Parameters

With the "Temperature Channel" parameter you select the temperature to be monitored; when, in heating, it exceeds the value selected with the "Temperature Limit" parameter, the thermostat changes its operating mode and switches to OFF-PROTECTED sending an alarm signal with the object *Floor Temperature Alarm*.

The thermostat comes out of the alarm condition when the temperature drops below the set threshold by at least 2°C.

The typical application for this function is that of limiting the maximum temperature of the floor.

Temperature channel Outside temperature 7 ▾

Temperature limit 35 °C

Temperature Protection

ETS text	Values available [Default value]	Comment
Temperature channel	0 = Off	Limitation disabled
	1 = Internal sensor	The internal sensor is used for temperature limitation
	2 = External temperature 1	The External Temperature 1 is used for temperature limitation
	3 = External temperature 2	The External Temperature 2 is used for temperature limitation
	4 = External temperature 3	The External Temperature 3 is used for temperature limitation
	5 = External temperature 4	The External Temperature 4 is used for temperature limitation
	6 = External temperature 5	The External Temperature 5 is used for temperature limitation
	7 = External temperature 6	The External Temperature 6 is used for temperature limitation
	8 = External temperature 7	The External Temperature 7 is used for temperature limitation
	9 = External temperature 8	The External Temperature 8 is used for temperature limitation
	[Off]	
Temperature limit	10...70 °C	Limit of the temperature channel beyond which the limitation trips
	[35]	

Communication objects and ETS parameters

Dewpoint Parameters

The dewpoint calculation is used to prevent the formation of condensation when the system is working in cooling mode. The calculation requires the temperature and room humidity. For both values, the sensors inside the multisensor can be used or they can be received from the Bus utilising remote sensors. The dewpoint calculation provides a value that must be compared with the delivery temperature which can be fixed (decided upon by the installer) or it can be received from the Bus utilising a remote sensor. If the Delivery temperature is below the calculated dewpoint temperature, the multisensor closes the valve, sends the dewpoint temperature on the bus and signals the alarm condition on the bus.

This paragraph describes the parameters to allow the dewpoint calculation.

DewPoint Calculation

Local

Flow temperature input from bus enable disable

Fixed flow temperature °C

Ambient temperature for dewpoint From bus Local

Dewpoint humidity sensor From bus Local

Dewpoint humidity receiving object Humidity (2bytes) Percentual (1byte)

Send Cycle Time

Send Difference

Dewpoint

ETS text	Values available [Default value]	Comment
Dewpoint calculation	Off	To enable the function and decide whether the calculation is done internally or if it receives the alarm from the bus
	Local	
	Alarm from bus	
	[Off]	
Delivery temperature input from bus	Disable	To decide whether the delivery temperature is received through an object from the bus
	Enable	
	[Disable]	
Fixed delivery temperature	10°C, 11°C, ..., .20°C	Temperature used in the event that the "Delivery Temperature Thermostat Input from Bus" parameter is disabled
	[16]	
Room temperature to calculate the dewpoint	Local	To decide whether the room temperature used for the dewpoint calculation is the one from the internal sensor in the device or if it is received from the bus.
	From bus	
	[Local]	
Dewpoint humidity sensor	Local	To decide whether the humidity used for the dewpoint calculation is the one from the internal sensor in the device or if it is received from the bus.
	From bus	
	[Local]	
Dewpoint humidity receiving object	Humidity (2 bytes)	To define the format of the humidity data received from the bus
	Percentage (1 byte)	
	[Humidity (2 bytes)]	
Send cycle time	Off, 30s, 1min, ..., 30min	Sets the frequency in minutes with which the thermostat must send to the dewpoint alarm object and to the object with the dewpoint temperature
	[Off]	
Send difference	Off, 0.°C, 0.2°C, ..., 1.0°C	Sets the variation threshold to send to the dewpoint alarm object and to the object with the dewpoint temperature
	[Off]	
Dewpoint supervision time	Off, 30s, 1min, ..., 30min	Sets the time within which the thermostat must receive a message on the "Dewpoint" object from a device connected to a humidistat. A bit set to "1" will stop heating/air conditioning and set to "0" will cause it to restart. If messages have not arrived, when this time has elapsed heating/air conditioning will restart
	[Off]	

Communication objects and ETS parameters

Anti-stratification Parameter

The anti-stratification function is useful in very high environments (gyms, lobbies, etc.) where the hot air tends to stratify at the top.

To avoid this phenomenon, fans need to be activated to circulate the air when the different in temperature between the high part and the low part of the room exceeds a settable threshold.

The anti-stratification function

- requires the measurement of the room air temperature at two heights with the installation of a second temperature probe at an appropriate height to measure the actual stratification of the room air mass; the main temperature sensor is assumed to be installed at 1.50 m above floor level
- activates ventilation only, at the lowest speed, when a temperature difference greater than the setpoint is detected by the two probes, whilst the inlet valve for the heat transfer fluid to the heating coil remains closed.

This paragraph describes the parameters to manage the anti-stratification function.

ETS text	Values available [Default value]	Comment
Anti-stratification function	Disable	To enable the anti-stratification function
	Enable [Disable]	
Temperature in the lower part of the room	Internal sensor	To decide whether the temperature in the lower part of the room is the one read by the internal sensor or whether it is received through an object from the bus
	External temperature 1	
	External temperature 2	
	External temperature 3	
	External temperature 4	
	External temperature 5	
	External temperature 6	
	External temperature 7	
	External temperature 8 [Internal sensor]	
Temperature in the upper part of the room	Internal sensor	To decide whether the temperature in the upper part of the room is the one read by the internal sensor or whether it is received through an object from the bus
	External temperature 1	
	External temperature 2	
	External temperature 3	
	External temperature 4	
	External temperature 5	
	External temperature 6	
	External temperature 7	
	External temperature 8 [External temperature]	

Continued

Anti-stratification function enable disable

Temperature of the lower part of the room: Internal sensor

Temperature of the upper part of the room: Outside temperature 1

Delta Temperature: 2,0 °C

Anti-stratification

Continued

ETS text	Values available [Default value]	Comment
Temperature delta	-5°C, -4.9°C, ..., 4.9°C, 5.0°C	Sets the temperature difference threshold between the upper and lower part of the room to activate the fans. This function activates the main outputs of the heating and cooling fans (where enabled) as follows: - Speed 1 if the output is type 3 speed on/off - Speed 33% if the output is type 3 proportional speed - The speed with minimum value if the output is proportional type - The speed with minimum value in the case of "split/VRV integration"
	[2.0°C]	

Communication objects and ETS parameters

Air quality sensor

The VOC (volatile organic compounds) sensor allows the air quality variations to be shown on the display or to be sent to the bus. It also allows the sending of an On/Off control or to call up 2 scenarios when the air quality worsens or improves with respect to parameters set during the configuration phase. The VOC sensor, in combination with temperature and humidity, makes it possible to manage ventilation to improve the quality of the air.

Air quality sensor Local ▼

Send Cycle Time off ▼

Send Difference enable disable

Air quality sensor

Air quality sensor Parameters

ETS text	Values available [Default value]	Comment
Air quality sensor	Off	To enable the air quality sensor management
	Local	
	From bus	
	[Local]	
Send cycle time	Off, 30s, 1min, ..., 30min	Sets the frequency in minutes at which the device needs to send to the object that signals the air quality index (stable, worsening, rapidly worsening). This parameter is only available if the air quality sensor used is the local one, in other words inside the device.
	[Off]	
Send difference	Disable	Sets the variation threshold to send to the object that signals the air quality index (stable, worsening, rapidly worsening). This parameter is only available if the air quality sensor used is the local one, in other words inside the device.
	Enable	
	[Disable]	

Communication objects and ETS parameters

Air quality control Parameters

ETS text	Values available [Default value]	Comment
Object type	Off	To enable the sending of controls upon worsening or improvement of the air quality.
	ON/OFF	
	Scenario	
	Value	
	[Off]	
Thermostat connection with air quality status	Enable	When this parameter is active, air quality control logic only works if it is in an ON operating mode. If the parameter is off, the air quality control logic always works.
	Disable	
	[Disable]	
Air quality threshold	Stable air	Indicates the value beyond which the air quality event occurs. This parameter is available if the "Object type" is "ON/OFF" or "Scenario".
	Air worsening	
	Air rapidly worsening	
	[Air rapidly worsening]	
Logic function	More than or equal to	To configure the logic to trigger the air quality event, with respect to the threshold value set. This parameter is only available if the "Object type" is "ON/OFF".
	Less than or equal to	
	[Less than or equal to]	
Scenario with air worsening	Enable	To enable the scenario with air worsening. This parameter is only available if the "Object type" is "Scenario".
	Disable	
	[Disable]	
Scenario	1, ..., 64	Number of the scenario to call up This parameter is only available if the "Object type" is "Scenario".
	[1]	
Scenario with air improving	Enable	To enable the scenario with air improving. This parameter is only available if the "Object type" is "Scenario".
	Disable	
	[Disable]	
Scenario	1, ..., 64	Number of the scenario to call up This parameter is only available if the "Object type" is "Scenario".
	[1]	
Value for stable air	0%, 1% ... 100%	Value to send with stable air. This parameter is only available if the "Object type" is "Value".
	[0%]	
Value for air worsening	0%, 1% ... 100%	Value to send when the air is worsening. This parameter is only available if the "Object type" is "Value".
	[66%]	
Value for air rapidly worsening	0%, 1% ... 100%	Value to send when the air is rapidly worsening. This parameter is only available if the "Object type" is "Value".
	[100%]	

Object type Scene ▼

Thermostat connection with air quality status enable disable

Air quality threshold Air rapidly worsening ▼

Scene when the air is getting worse enable disable

Scene 1 ▼

Scene when the air is getting better enable disable

Scene 1 ▼

Air quality control

Communication objects and ETS parameters

Humidity sensor

The humidistat is designed to view the current humidity value on the display or send it on the bus. It also allows the sending of an On/Off control on the bus when the humidity value increases or decreases with respect to a parameter set during the configuration phase. It can be used to manage ventilation and for dewpoint management, in combination with the temperature and VRV systems.

Humidity Sensor Parameters

ETS text	Values available [Default value]	Comment
Humidity sensor	Off	To enable the of the humidity sensor management
	Local	
	From bus	
	[Local]	
Send cycle time	Off, 30s, 1min, ..., 30min	Sets the frequency in minutes with which the device must send to the object that indicates the current humidity. This parameter is only available if the humidity sensor used is the local one, in other words inside the device.
	[Off]	
Send difference	Off, 1%, 2%, ..., 10%	Sets the variation threshold to send to the object that indicates the current humidity. This parameter is only available if the humidity sensor used is the local one, in other words inside the device.
	[Off]	
Humidity offset	-29%,, 0%, 1%, 2%,, 30%	Calibration of the internal humidity probe reading or of the data received from the bus.
	[0%]	

Continued

Humidistat Parameters

ETS text	Values available [Default value]	Comment
Control humidity sensor	Enable	To enable the sending of controls upon rising or lowering of the humidity.
	Disable	
	[Disable]	
Thermostat connection with humidity status	Enable	When this parameter is active, humidity control logic only works if it is in an ON operating mode. If the parameter is off, the humidity control logic always works.
	Disable	
	[Disable]	
Humidity threshold 1	0%, 1%,, 100%	Indicates the value above or below which a control is sent on the bus.
	[0%]	
Hysteresis threshold 1	0%, 1%,, 100%	Humidity differential of humidity threshold 1. Only influences the OFF message transmission.
	[0%]	
Trigger 1 logic	More than or equal to	To configure the logic to trigger the humidity event, with respect to the threshold value set.
	Less than or equal to	
	[Less than or equal to]	
Humidity threshold 2	0%, 1%,, 100%	Indicates the value above or below which a control is sent on the bus.
	[0%]	

Continued

Humidity sensor From bus ▾

Humidity offset 0% ▾

Humidity receiving object Humidity (2bytes) Percentual (1byte)

Humidity sensor from bus

Humidity sensor Local ▾

Send Cycle Time off ▾

Send Difference off ▾

Humidity offset 0% ▾

Humidity transmitting object Humidity (2bytes) Percentual (1byte)

Local Humidity sensor

Continued

ETS text	Values available [Default value]	Comment
Humidity receiving object	Humidity (2 bytes)	To decide on the type of reception data. This parameter is only available if the humidity values used come from the Bus.
	Percentage (1 byte)	
	[Humidity (2 bytes)]	
Humidity transmitting object	Humidity (2 bytes)	To decide on the type of reception data. This parameter is only available if the humidity sensor used is the local one, in other words inside the device.
	Percentage (1 byte)	
	[Humidity (2 bytes)]	

Humidistat enable disable

Thermostat connection with humidity status enable disable

Humidity threshold 1 50 %

Threshold 1 hysteresis 5 %

Trigger logic 1 More than or equal to Less than or equal to

Humidity threshold 2 50 %

Threshold 2 hysteresis 5 %

Trigger logic 2 More than or equal to Less than or equal to

Humidistat

Continued

ETS text	Values available [Default value]	Comment
Hysteresis threshold 2	0%, 1%,, 100%	Humidity differential of humidity threshold 2. Only influences the OFF message transmission.
	[0%]	
Trigger 2 logic	More than or equal to	To configure the logic to trigger the humidity event, with respect to the threshold value set.
	Less than or equal to	
	[Less than or equal to]	

Communication objects and ETS parameters

Room number

The "Room number" function allows the viewing of a number from 0 to 9999. You can choose the number and the number of digits to view. For instance, number 35 can be viewed as 35, 035 or 0035.

In addition to the number, 2 functions are available and ready to be enabled:

- The bell
- The amber signalling LED

Room number Parameters

ETS text	Values available [Default value]	Comment
Room number	0...9999 [0]	Used to select the number to view on the display
Minimum number of digits	1,2,3,4 [1]	Indicates the number of digits to view on the display

Continued

Keys

Each key can be configured like a push button or 2 buttons can be joined together to act as a switching module (rocker button).

Button configuration

ETS text	Values available [Default value]	Comment
Basic function of keys	0 = off	"Push button" can be used as "Switching module with one object", "Switching module with multiple objects", "Single push button dimmer control" or "Roller shutter single push button control" or "Viewing only". "Switching module" can be used as "ON/OFF switching", "Dimmer control" or "Roller Shutters"
	1 = push button	
	2 = switching module	
	[0]	

PUSH BUTTON Mode

Each key can operate as a push button.

The parameter configuration is shown in the table below.

Push button configuration

ETS text	Values available [Default value]	Comment
Function	255 = Off	Identical for upper, lower keys
	0 = switching one object	
	1 = switching multiple objects	
	2 = single push button dimming	
	3 = single push button roller shutter control	
	4 = viewing only	
[Off]		

Room Number

Minimum number of digits

Preview 035

Doorbell enable disable

Room number

Continued

ETS text	Values available [Default value]	Comment
Preview		Shows the result obtained when choosing the "Room number" and the "Minimum number of Digits"
Bell	Enable	To enable the bell function. If enabled, the display shows a dot on the lower button to indicate where to press and object 189 is available to send a 1 bit control.
	Disable	
	[Disable]	

Basic Function of keys

✓

Button configuration

Basic Function of keys

Function Upper Key

Operation type

Short press function

Long press Function

Scene

Block function Disable Enable

Block value 1 value 0 value

Block function at power up

Function Lower Key

Shutter Behaviour

Send stop on Release No Yes

Block function Disable Enable

Push button configuration

Communication objects and ETS parameters

Let's look in detail at the **functions that can be associated** with the button set as "Push button".

"Switching one object" parameters

ETS text	Values available [Default value]	Comment
Value to send	0 = send ON	Possibility of choosing whether to send an ON message, an OFF message, an ON message with a set time or with trigger control
	1 = send OFF	
	2 = timed ON	
	3 = trigger control	
	[0]	
Time in seconds	1...32000 s [30]	Only if timed

Function Upper Key



"Switching one object" parameter

"Switching multiple objects" parameters

ETS text	Values available [Default value]	Comment
Operation type	0 = On the edge	Possibility of choosing the behaviour and sending over multiple objects
	1 = Short/Long press	
	2 = Force	
	3 = Value	
	4 = Sequence	
	5 = Multiple presses	
	[0]	

Function Upper Key

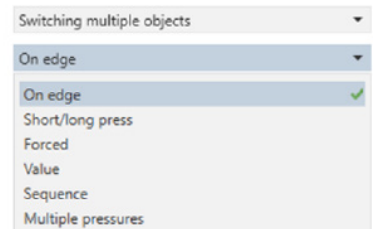

Operation type



Value on Rising Edge

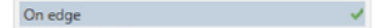

Value on Falling Edge

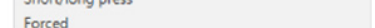

Block function

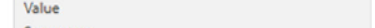

"Switching multiple objects" parameter

"Switching multiple objects/on the edge" parameters

To obtain a "Bell" ON/OFF and OFF/ON function.

ETS text	Values available [Default value]	Comment
Value on the rising edge	0 = OFF	On pressing the push button it will send ON or OFF
	1 = ON	
	[1]	
Value on the falling edge	0 = OFF	On releasing the push button it will send ON or OFF
	1 = ON	
	[0]	

Function Upper Key

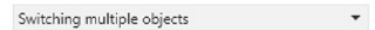

Operation type

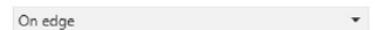

Value on Rising Edge



Value on Falling Edge



Block function



Block value



Block function at power up

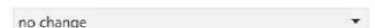

"Switching multiple objects/on the edge" parameter

Communication objects and ETS parameters

"Switching multiple objects/Short-long press" parameter with Toggle and ON/OFF" options

To send cyclic ON/OFF messages with push button.

ETS text	Values available [Default value]	Comment
Short press function	No reaction	Possibility of choosing the message to send on a short press of the push button. By choosing "Toggle", ON/OFF/ON etc. will be sent in sequence with each press of the push button. Both the control object and the push button "Status" object must be associated with the group
	Toggle	
	Send ON	
	Send OFF	
	[Toggle]	
Long press function	No reaction	Possibility of choosing the message to send on a short press of the push button. By choosing "Toggle", ON/OFF/ON etc. will be sent in sequence with each press of the push button. Both the control object and the push button "Status" object must be associated with the group
	Toggle	
	Send ON	
	Send OFF	
	[Toggle]	
LED status object	ON/OFF status - short press	Allows you to determine whether the LED aligns with the status object for short or long press
	ON/OFF status - long press	
	[ON/OFF status - short press]	

Function Upper Key	Switching multiple objects
Operation type	Short/long press
Short press function	Toggle
Long press Function	Send On
Led State Object	<input checked="" type="radio"/> Status On/off - short press <input type="radio"/> Status On/off - long press
Block function	<input type="radio"/> Disable <input checked="" type="radio"/> Enable
Block value	<input checked="" type="radio"/> 1 value <input type="radio"/> 0 value
Block function at power up	no change

"Switching multiple objects/Short-long press" parameters with Toggle and ON/OFF" options

"Switching multiple objects/Short-long press" parameter with options for the scenario

A scenario can be activated or stored.

ETS text	Values available [Default value]	Comment
Short press function	0 = no action	If enabled, a short push button press saves a scenario in the bus or calls up a scenario
	1 = save scenario	
	2 = call up scenario	
	[0]	
Scenario	1-64	Number of the scenario called up or saved on short press
	[1]	
Long press function	0 = no action	If enabled, a prolonged push button press saves a scenario in the bus or calls up a scenario
	1 = save scenario	
	2 = call up scenario	
	[0]	
Long press scenario	1-64	Number of the scenario called up or saved on long press
	[1]	

Communication objects and ETS parameters

"Switching multiple objects/Forcing" parameter

The push button can be used for forcing functions.

ETS text	Values available [Default value]	Comment
Short press function	0 = no reaction	To send forced ON or OFF controls and to disable forcing on short press
	1 = forced ON	
	2 = forced OFF	
	3 = disable forcing	
	[0]	
Long press function	0 = no reaction	To send forced ON or OFF controls and to disable forcing on long press
	1 = forced ON	
	2 = forced OFF	
	3 = disable forcing	
	[0]	

Function Upper Key: Switching multiple objects

Operation type: Forced

Short press function: Forced On

Long press Function: Forced disable

Block function: Disable Enable

Block value: 1 value 0 value

Block function at power up: no change

"Switching multiple objects/Forcing" parameter

"Switching multiple objects/Value" parameter

To send a value 0÷255 on short or long push button press.

ETS text	Values available [Default value]	Comment
Short press function	0÷255	Sends a value between "0" and "255" over the bus on a long push button press
Enables second value on long press	Yes	To enable a second value to send on long press
	No	
	[No]	
Long press function	0÷255	Sends a value between "0" and "255" over the bus on a long push button press

Function Upper Key: Switching multiple objects

Operation type: Value

Short press function: 0

Long press second Value: No Yes

Long press Function: 215

Block function: Disable Enable

Block value: 1 value 0 value

Block function at power up: no change

Function Lower Key: Disabled

"Switching multiple objects/Value" parameter

Communication objects and ETS parameters

"Switching multiple objects/Sequence" parameters

ETS text	Values available [Default value]	Comment
Data format	0 = 1 bit	Type of data to send
	1 = 1 byte	
	[0]	
If data format = 1 bit		
Sequence type	0 = Cyclic	By choosing cyclic sequence, for each press the data on the objects Value 1, Value 2, Value 3, Value 4, Value 1, Value 2, Value 3, Value 4... are sent By choosing increasing/decreasing sequence, the data on the objects Value 1, Value 2, Value 3, Value 4, Value 3, Value 2, Value 1, Value 2, Value 3, Value 4... are sent
	1 = Increasing/Decreasing	
	[0]	
Number of objects	0÷4	Number of objects concerned in the sequence for short press
	[2]	
Value 1..n	0 = ON	ON or OFF values to send for short press
	1 = OFF	
	[1]	
Long press function	Disable	Enabling of the sequence function for long press
	Enable	
	[Disable]	
Number of objects	0÷4	Number of objects concerned in the sequence for long press
	[2]	
Value 1..n	0 = ON	ON or OFF values to send for long press
	1 = OFF	
	[1]	
If data format = 1 byte		
Sequence type	0 = Cyclic	By choosing cyclic sequence, for each press of the dedicated object, the data on the objects Value 1, Value 2, Value 3, Value 4, Value 1, Value 2, Value 3, Value 4... are sent By choosing increasing/decreasing sequence, the data Value 1, Value 2, Value 3, Value 4, Value 3, Value 2, Value 1, Value 2, Value 3, Value 4... are sent
	1 = Increasing/Decreasing	
	[0]	
Number of values	0÷4	Number of different values to send in the sequence for short press
	[2]	
Value 1..n	0÷255	Values to send for short press
	[0]	
Long press function	Disable	Enabling of the sequence function for long press
	Enable	
	[Disable]	
Number of values	0÷4	Number of different values to send in the sequence for long press
	[2]	
Value 1..n	0÷255	Values to send for long press
	[0]	

Function Upper Key: Switching multiple objects

Operation type: Sequence

Data format: 1 Bit 1 Byte

Sequence type: Cycling Increasing/Decreasing

Number of objects: 4

Value 1: On Off

Value 2: On Off

Value 3: On Off

Value 4: On Off

Long press Function: Disable Enable

Number of objects: 4

Value 1: On Off

Value 2: On Off

Value 3: On Off

Value 4: On Off

Block function: Disable Enable

Block value: 1 value 0 value

Block function at power up: no change

"Switching module with multiple objects/Sequence" parameters

Communication objects and ETS parameters

"Switching multiple objects/Multiple presses" parameters

ETS text	Values available [Default value]	Comment
Message sending	0 = Each single press 1 = Only at the end of pressing [0]	To establish whether to send the messages at all presses in the series or only at the end of the series.
Maximum time between presses	100÷32000 ms [500]	This time determines the end of the series of presses
Data format	0 = 1 bit 1 = 1 byte 2 = 2 byte [0]	Type of data to send
Value to send (if data format = 1bit)	0 = OFF 1 = ON 2 = Toggle [0]	1 bit values to send for short press
Value 1..n (if data format = 1byte)	0÷255 [0]	1 byte values to send for short press
Value 1..n (if data format = 2byte)	0÷ 65535 [0]	2 byte values to send for short press
Second press detection	Disable Enable [Disable]	Enabling management of second press
Data format	0 = 1 bit 1 = 1 byte 2 = 2 byte [0]	Type of data to send
Value to send (if data format = 1bit)	0 = OFF 1 = ON 2 = Toggle [0]	1 bit values to send for short press
Value 1..n (if data format = 1byte)	0÷255 [0]	1 byte values to send for short press
Value 1..n (if data format = 2byte)	0÷ 65535 [0]	2 byte values to send for short press
Third press detection	Disable Enable [Disable]	Enabling management of third press
Data format	0 = 1 bit 1 = 1 byte 2 = 2 byte [0]	Type of data to send
Value to send (if data format = 1bit)	0 = OFF 1 = ON 2 = Toggle [0]	1 bit values to send for short press
Value 1..n (if data format = 1byte)	0÷255 [0]	1 byte values to send for short press
Value 1..n (if data format = 2byte)	0÷ 65535 [0]	2 byte values to send for short press
Fourth press detection	Disable Enable [Disable]	Enabling management of fourth press

Function Upper Key: Switching multiple objects

Operation type: Multiple presses

Message sending: Every single press Only at the end of the pressure

Max time between presses: 500 [ms]

Data format: 2 Byte

Value to send: 1

Second press detection: Disable Enable

Data format: 1 bit

Value to send: on

Third press detection: Disable Enable

Fourth press detection: Disable Enable

Long press Function: Save Scene

Scene: 1

Block function: Disable Enable

Block value: 1 value 0 value

Block function at power up: no change

"Switching multiple objects/Multiple presses" parameter

Continued

ETS text	Values available [Default value]	Comment
Data format	0 = 1 bit 1 = 1 byte 2 = 2 byte [0]	Type of data to send
Value to send (if data format = 1bit)	0 = OFF 1 = ON 2 = Toggle [0]	1 bit values to send for short press
Value 1..n (if data format = 1byte)	0÷255 [0]	1 byte values to send for short press
Value 1..n (if data format = 2byte)	0÷ 65535 [0]	2 byte values to send for short press
Long press function	No reaction Toggle Send ON Send OFF Save scenario Call up scenario [No reaction]	To enable the sending of a message for long press
Scenario	1..64 [1]	Number of the scenario called up or saved on long press

Continued

Communication objects and ETS parameters

“Single push button dimmer control” parameter

Dimmer control with a single push button.

ETS text	Values available [Default value]	Comment
Dimming step	1.5....100% [100%]	Sets the dimming speed
Repeat dimming telegrams	0 = No 1 = Yes [0]	Sets the dimming mode (continuous or step-step)
Repetition time	0.3....5 s [1.0 s]	Control message repetition time
Dimmer behaviour	Toggle (short) up/down dimming (long)	Possibility of choosing the behaviour for short and long press
	ON (short) dimming up (long)	
	OFF (short) dimming down (long)	
	[Toggle (short) up/down dimming (long)]	

Function Upper Key: Single Key Dimming

Dimming steps: 100%

Repeat Dimming Telegrams: No Yes

Repetition time: 1.0 s

Dimmer Behaviour: Off (short), Dimming Down (long)

Block function: Disable Enable

Block value: 1 value 0 value

Block function at power up: no change

“Single push button dimmer control” parameters

“Single push button roller shutter control” parameter

Roller shutter control with a single push button.

ETS text	Values available [Default value]	Comment
Roller shutter behaviour	Roller shutter up (long press), stop/step (short press)	Possibility of choosing the behaviour for short and long press
	Roller shutter down (long press), stop/step (short press)	
	Roller shutter toggle movement (long press), stop (short press)	
	Roller shutter up (short press), stop/step (long press)	
	Roller shutter down (short press), stop/step (long press)	
	Roller shutter toggle movement (short press), stop (long press)	
Send stop on release	0 = No 1 = Yes [0]	Possibility of choosing whether to send the stop when the push button is released

Function Upper Key: Single Key Shutter

Shutter Behaviour: Shutter Movement UP (long), Stop/Step(short)

Send stop on Release: No Yes

Block function: Disable Enable

Block value: 1 value 0 value

Block function at power up: no change

Function Lower Key: Disabled

“Single push button roller shutter control” parameters

Note.

By setting “Push button” and selecting the “Single push button dimming” function or the “Toggle object” function or the “Single push button roller shutter control” function, this object must be associated with the group with the light “ON/OFF status” datapoint (relay or dimmer) or the roller shutter “roller shutter up/down” datapoint to receive the ON/OFF status of the associated load. If this is not the case, it will be unable to manage light control or roller shutter operation.

“Viewing only” parameter

The LED or LED matrix corresponding to a button can be used simply to view a status without pressing the button performing an action.

ETS text	Values available [Default value]	Comment
LED behaviour	Object received	Allows you to decide whether the LED (or LED matrix) shows the status received on “LED status” or whether it always stays on
	Always on	
	[Object received]	

Basic Function of keys: Pushbutton

Function Upper Key: View only

Led Behaviour: Received object Always On

“Viewing only” settings

Communication objects and ETS parameters

"Definition of the button LED matrix" parameter

The parameters of the LED matrix corresponding to the buttons configured as push buttons can be set by choosing an icon and, in the case of a scenario call up push button, an animation.

ETS text	Values available [Default value]	Comment
Upper icon	Dot	Allows you to choose the icon shown by the LED matrix corresponding to the upper button
	...	
	Minus (small)	
	[Dot]	
Preview		Shows the image chosen in the "Upper icon" parameter
Lower icon	Dot	Allows you to choose the icon shown by the LED matrix corresponding to the lower button
	...	
	Minus (small)	
	[Dot]	
Preview		Shows the image chosen in the "lower icon" parameter

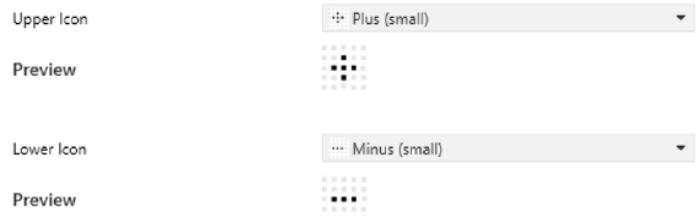

"Definition of the button LED matrix" parameters

Let's look in detail at the **functions that can be associated** with the button set as **"Switching module"**.

"Switching module" configuration

For relay controls, dimmers, roller shutters with two push buttons acting as a switching module.

ETS text	Values available [Default value]	Comment
Function	0 = ON/OFF switching	
	1 = dimmer control	
	2 = roller shutters	
	[0]	



"Switching module" parameters

"ON/OFF switching" parameter

To perform On/Off with 2 push buttons that make up the switching module.

ETS text	Values available [Default value]	Comment
Toggle	Enable	If active, you can perform a toggle regardless of whether you press the upper or lower button
	Disable	
	[Enable]	



"ON/OFF switching" parameters

Communication objects and ETS parameters

“Dimmer control” Parameter

ETS text	Values available [Default value]	Comment
Dimming step	0...100% [100%]	Sets the control speed
Repeat dimming telegrams	0 = No 1 = Yes [0]	Possibility of choosing whether to repeat the dimming control
Repetition time	0.3...5 s [1.0 s]	Control message repetition time
Toggle	Enable	If active, you can perform a toggle regardless of whether you press the upper or lower button
	Disable	
	[Enable]	

Basic Function of keys Switch

Function Dimming

Toggle Disable Enable

Dimming steps 100%

Repeat Dimming Telegrams No Yes

Repetition time 1.0 s

Block function Disable Enable

Block value 1 value 0 value

Block function at power up no change

“Dimmer control” Parameters

“Roller shutter” parameters

ETS text	Values available [Default value]	Comment
Functionality for rocker press	Roller shutter movement (long), Stop/Step (short)	Possibility of choosing the behaviour for short and long press
	Roller shutter movement (short), Stop/Step (long)	
	[Roller shutter movement (long), Stop/Step (short)]	
Send stop on release	0 = No	Possibility of choosing whether to send the stop when the push button is released
	1 = Yes	
	[0]	

Basic Function of keys Switch

Function Shutters

Functionality for rocker press Shutter Movement (long), Stop/Step(short) Shutter Movement (short), Stop/Step(long)

Send stop on Release No Yes

Block function Disable Enable

Block value 1 value 0 value

Block function at power up no change

“Roller shutter control” parameters

Communication objects and ETS parameters

"Definition of the LED matrices for the switching module" parameter

The parameters of the LED matrices corresponding to the buttons can be set by choosing an icon and, in the case of the central matrix, an animation.

ETS text	Values available [Default value]	Comment
Upper icon	Off	Allows you to choose the icon shown by the LED matrix corresponding to the upper button
	Dot	
	...	
	Minus (small)	
	[Up arrow]	
Preview		Shows the image chosen in the "Upper icon" parameter
Central icon	Off	Allows you to choose the icon shown by the LED matrix corresponding to the central icon
	Dot	
	...	
	Minus (small)	
	[Roller shutter/Blind]	
Preview		Shows the image chosen in the "Central icon" parameter
Central animation on long pressing upper push button	Off	Allows you to choose the animation displayed by the central LED matrix in the case of value increase
	...	
	Blind movement (from right to left)	
	[Roller shutter/Blind Opening]	
Central animation on long pressing lower push button	Off	Allows you to choose the animation displayed by the central LED matrix in the case of value decrease
	...	
	Blind movement (from right to left)	
	[Roller shutter/Blind Closing]	
Lower icon	Off	Allows you to choose the icon shown by the LED matrix corresponding to the lower button
	Dot	
	...	
	Minus (small)	
	[Down arrow]	
Preview		Shows the image chosen in the "lower icon" parameter

Upper Icon Up Arrow ▼

Preview 

Central icon Shutter/Curtain (State) ▼

Preview

Central animation on long pressing upper push button Roller shutter/Curtain Opening ▼

Central animation on long pressing lower push button Roller shutter/Curtain Closing ▼

Lower Icon Down Arrow ▼

Preview 

"Definition of the LED matrices for the switching module" parameters

Communication objects and ETS parameters

"Block function" parameter

For each button configured as a push button, you can enable an object allowing the button operation to be blocked. In the event that the buttons are configured as switching module, the object blocks both buttons.

ETS text	Values available [Default value]	Comment
Block function	Disable	Parameter for enabling the block function and making the related object available
	Enable [Disable]	
Block value	Value 1	To choose whether the block function is active when it receives the value 0 or the value 1 from the bus
	Value 0	
	[Value 1]	
Block function at power up	No change	To choose whether, following a power down, the block remains in the same status it was in before the power down, whether it is deactivated or activated
	Off	
	On	
	[No change]	

Block function Disable Enable

Block value 1 value 0 value

Block function at power up no change ▼

"Block function" parameters

Central LEDs

The central LED matrix can be used independently when the buttons are used in "push button" configuration. The parameters of the matrix icon can be set choosing from a list.

Parameter configuration

ETS text	Values available [Default value]	Comment
Function	Off	Allows you to enable and choose the type of display on the central matrix
	ON/OFF	
	Alarm	
	Scenario	
	[Off]	
Flashing speed	Fast	If the function is "Alarm", it allows you to set the flashing speed
	Slow	
	[Slow]	
Scenario	1..64	If the function is "Scenario", it allows you to choose the number of the scenario
	[1]	
Icon	Off	Allows you to choose the icon shown by the LED matrix
	Dot	
	...	
	Left scale	
	[Depends on the "Function" parameter]	
Preview		Shows the image chosen in the "Central icon" parameter
Central LED matrix day standby brightness (scenario not activated)	Off	To choose the day standby brightness in the event that the function is "Scenario"
	Low	
	Medium	
	High [High]	
Central LED matrix day standby brightness (scenario activated - 3 sec)	Off	To choose the day standby brightness in the event that the function is "Scenario"
	Low	
	Medium	
	High [Low]	
Central LED matrix night standby brightness (scenario not activated)	Off	To choose the night standby brightness in the event that the function is "Scenario"
	Low	
	Medium	
	High [Medium]	

Continued

Function Scene ▼

Icon Favourite Scene ▼

Preview 

Scene 1 ▼

Central led matrix day standby brightness (scenario not activated) High ▼

Central led matrix day standby brightness (scenario activated - 3 sec) Low ▼

Central led matrix night standby brightness (scenario not activated) Medium ▼

Central led matrix night standby brightness (scenario activated - 3 sec) Low ▼

"Central LED/scenario" parameters

Function Alarm ▼

Icon Alarm ▼

Preview 

Flashing speed Fast Slow

"Central LED/alarm" parameters

Continued

ETS text	Values available [Default value]	Comment
Central LED night standby brightness (scenario activated - 3 sec)	Off	To choose the night standby brightness in the event that the function is "Scenario"
	Low	
	Medium	
	High [Low]	



32142EN 05 2605



VIMAR

Viale Vicenza 14
36063 Marostica VI - Italy
www.vimar.com