

Smart automation connected system.



Contents

1. Integrated connected systems platform	3
2. Basic concepts of the By-me Plus home automation system	4
2.1 The XT platform	7
3. Installation topology	8
3.1 Installation of bus systems	8
3.2 System dimensions	10
4. Configuration with View Pro App	11
4.1 Main screen of the home automation system gateway	11
4.2 Device enrolment	13
4.3 Creating applications	42
4.4 Special applications	70
4.5 Integration of By-alarm and video door entry devices with By-me Plus applications	93
4.6 Configuration of the weather station 01546	96
4.7 Configuration of actuator 01419.1 for DALI device integration	101
4.8 Logical programmes	109
4.9 Gateway management	11
4.10 By-me Plus home automation system management	112
4.11 Maintenance.....	115
5. Control devices	124
5.1 Devices	124
5.2 Functional units of art. 22481.x, 22482.x, 30480-01480, 30481-01481, 30482-01482, 30485-01485, 30486-01486 and 30487-01487	126
5.3 Parameters of art. 22481.x, 22482.x, 30480-01480, 30481-01481, 30482-01482, 30485-01485, 30486-01486 and 30487-01487	128
5.4 Functional units of art. 01475, 01476 and 01477	130
5.5 Parameters of art. 01475, 01476 and 01477	133
5.6 Functional units of art. 30488-01488 and 30489-01489	135
5.7 Parameters of art. 30488-01488 and 30489-01489	136
6. Actuators	140
6.1 Devices	140
6.2 Functional units of art. 01470.1	140
6.3 Parameters of art. 01470.1	142
6.4 Functional units of art. 01471	144
6.5 Parameters of art. 01471	144
6.6 Functional units of art. 01418	145
6.7 Parameters of art. 01418	145
6.8 The actuator and dimmer art. 01417	147
6.9 Functional units of art. 01417	147
6.10 Parameters of art. 01417	148
6.11 The DALI/DALI-2 lamp actuator	149
7. Sound system	152
7.1 General characteristics	152
7.2 Devices and functions	152
7.3 Installation rules and topology	155
7.4 System restrictions	157
7.5 Functions	161
7.6 System components	161
7.7 Device parameters	170
7.8 Types of system	171
8. Energy management	180
8.1 General characteristics	180
8.2 Devices and functions	180
8.3 Load control	181
8.4 Device parameters	188
9. Temperature control	190
9.1 General characteristics	190
9.2 Devices and functions	190
9.3 Configuration	191
9.4 Device parameters	199
10. Eikon Tactil devices	209
10.1 General characteristics	209
10.2 Devices and functions.....	209
10.3 Functional units of art. 21520.1 and 21540.1	209
10.4 Parameters of art. 21520.1 and 21540.1.....	210
10.5 Configuration of thermostat 21514.....	211
10.6 Parameters of of thermostat 21514.....	211

Contents

11. XT platform devices	221
11.1 General characteristics	221
11.2 Devices and functions.....	221
11.3 Functional units and parameters of XT actuator art. 32002	222
11.4 Functional units and parameters of XT controls art. 32021 and 32031.G	223
11.5 Functional units and parameters of XT advanced controls art. 32023 and 32033.G.....	225
11.6 Functional units and parameters of XT controls art. 32024 and 32034.G	227
11.7 Functional units and parameters of the XT control art. 32044.x	228
11.8 Functional units and parameters of the XT thermostat art. 32041.x.	229
11.9 Functional units and parameters of the XT Multisensor art. 32042.x.	232
11.10 Icons and animations	240
APPENDIX	242
I Summary table of By-me device absorption rates	242
II. Operation of actuators for art. 01470.1, 01471, 01476 and 01477	244
III. Examples of using the functional units of thermostats	248

Integrated connected systems platform

1. INTEGRATED CONNECTED SYSTEMS PLATFORM

The platform allows the interconnection of Vimar systems via a local IP network in which each system propagates the information about its own field bus, if not already IP, through a gateway.

The By-me Plus system, which interacts with the platform via gateway 01410-01411, should be configured using the View Pro App, thanks to which all the settings are made in relation to the devices for the control of lights and roller shutters, sound system, energy management and temperature control.

The example below illustrates an overview of the platform architecture in which the By-me Plus system and all the other systems converge via their respective gateways.

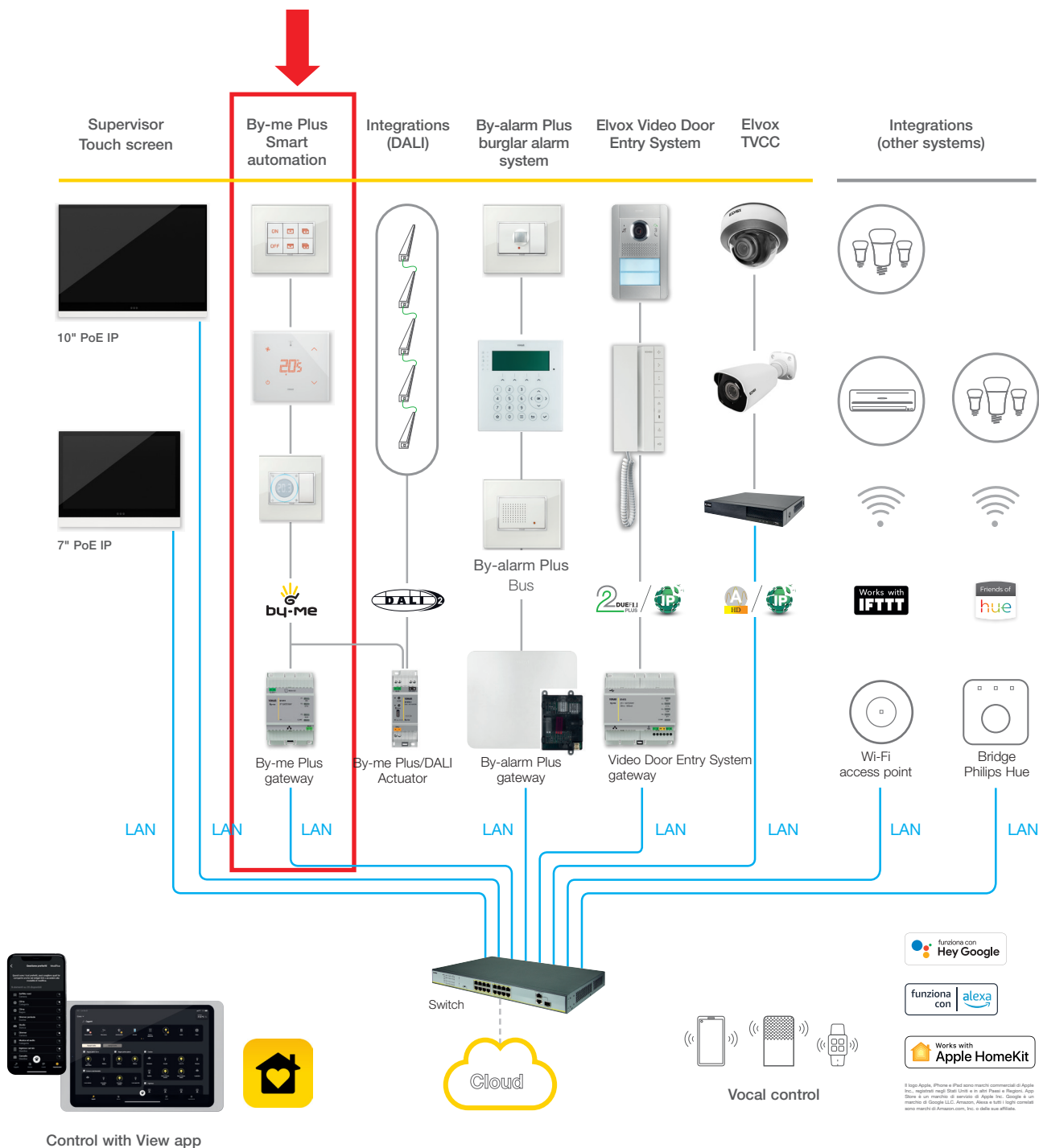

We recommend you use high-performance switches that guarantee the reliability of the IP-based platform (for instance Elvox switches). Avoid using the ports of consumer routers, because the type of filtering that may be applied to transiting data is not known in advance.

Basic concepts of the By-me Plus home automation system

2. BASIC CONCEPTS OF THE BY-ME PLUS HOME AUTOMATION SYSTEM

This chapter illustrates the fundamental concepts for the correct structuring of the By-me Plus system.

The By-me Plus system includes a comprehensive set of devices that cover the various needs of a home automation system; specifically, it makes controlling the lights and roller shutters, load control and energy management, temperature control and sound system control possible and automatable.

The modular control devices (art. art. 22481.x, 22482.x, 30480-01480, 30481-01481, 30482-01482, 30485-01485, 30486-01486, 30487-01487, 30488-01488 and 30489-01489) can be used transversely in By-me Plus systems or in integrated systems and they stand out for:

- styling and RGB backlighting (on Linea, Eikon and Arkè the symbols are back-lit);
- management of short, long and timed button press;
- single code for the three series: Eikon, Arkè and Plana (the half-button caps relating to the chosen wiring series are then fitted on the device);
- three types of device (with push buttons, with push buttons and relay actuator, with push buttons and roller shutter actuator);
- two types of modularity (2 and 3 modules):
 - 4 activations for 2-module devices (4 push buttons)
 - 6 activations for 3-module devices (6 push buttons)
- RGB LED with adjustable brightness (visible in darkness/night function), colour coordinated with the thermostats;
- reduced dimensions of flush mounting box.

The retrofit control devices (art. 01475, 01476 and 01477) can also be used transversely in By-me Plus systems or in integrated systems. The three articles are equipped with programmable digital inputs and outputs for LED control; art. 01476 and 01477 also have an output for roller shutters with slat orientation and a relay output for lighting control, respectively.

The DIN rail actuators art. 01470.1, 01471 enable connection to all types of load (lights, roller shutters, etc.) whereas art. 01418 is a dimmer actuator with 2 outputs designed to control and adjust incandescent lamps, CFLs, LEDs and electronic transformers. Their function is to actuate the control instruction received from the other devices in the system, from the scenarios, etc.

All By-me devices are structured to provide several functions, whose main characteristic is that they do not necessarily relate to one another; each of these functions is achieved by a logical cell referred to as a **functional unit**.

A **functional unit** can therefore be defined as part of a physical device that can be managed as an independent device.

Some examples:

1. The actuator with 16 A 250 V~ change-over relay output (Linea 30473, Eikon 20534; Arkè 19534; Plana 14534) is a device with **one** functional unit (the functional unit coincides with the device itself).
2. The interface for traditional controls (Linea 30472, Eikon 20518; Arkè 19518; Plana 14518) is a device with **two** functional units; each of the two inputs is a functional unit.
3. The 4-push button control device (art. 30480-01480) is a device with **six** functional units; upper left push button, lower left push button, upper right push button, lower right push button, left rocker button (seen as the set of upper and lower push button) and right rocker button (seen as the set of upper and lower right push button) which, in terms of configuration and operation, are in fact six distinct devices.
4. The control device with 6 push buttons and actuator with relay output (art. 30486-01486) is a device with **ten** functional units; upper left push button, lower left push button, upper central push button, lower central push button, upper right push button, lower right push button, left rocker button, central rocker button, right rocker button and relay actuator which, in terms of configuration and operation, are in fact ten distinct devices.

During the design phase, every functional unit of every device must be considered as an independent function. At the design stage, accordingly, the correct procedure is to establish the required functions initially, and only then make a list of the devices needed to perform them.

Below shows an illustration of the functional units of the control device with 6 push buttons and actuator with relay output (art. 30486-01486).

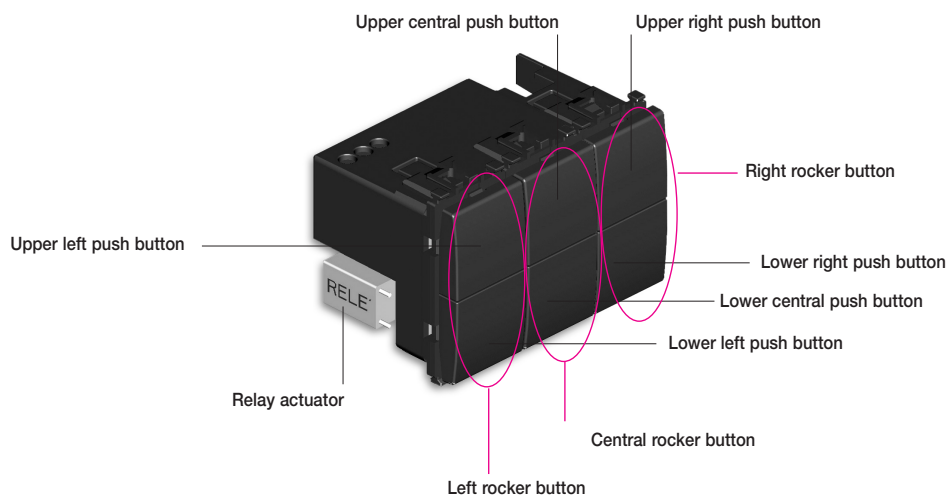

Basic concepts of the By-me Plus home automation system

For example, during installation, the actuator could be used to control load A via the push button of another device, the left, central and right button to control loads B, C and D via the actuator 01471.

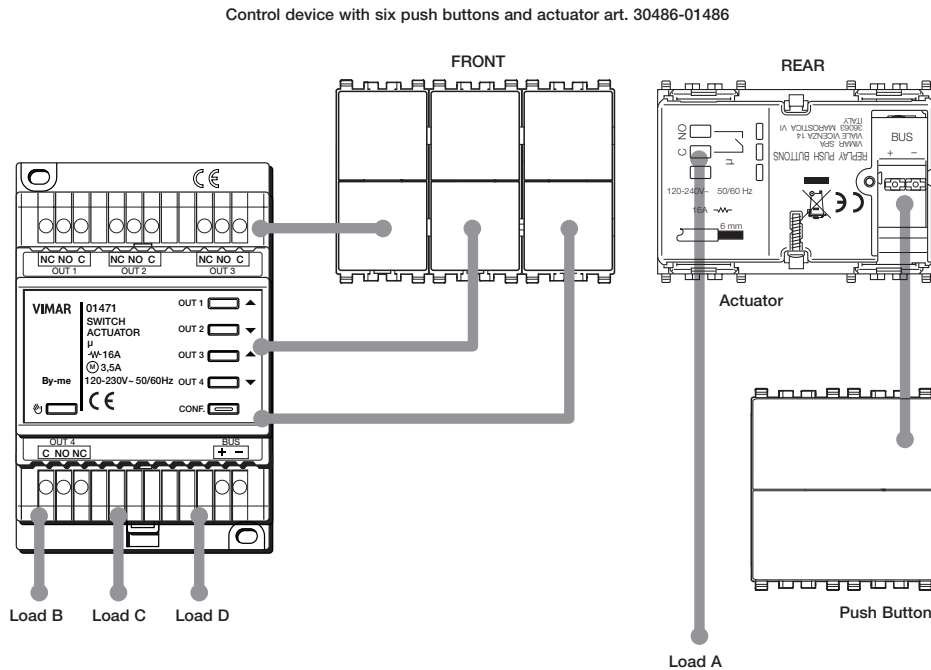

There are no constraints on the functional units of a physical device. When a load needs to be controlled, a device (control or supervisor) and an actuator connected to the load itself must be envisaged.

- **Application:** logical link between two functional units, which allows a function to be shared (for instance: three different push buttons that control a single actuator and, consequently, the same load).
- **Configuration:** operation that can be used to create the application between various functional units (of various devices).

The devices making up an application are interconnected logically and not according to traditional wiring.

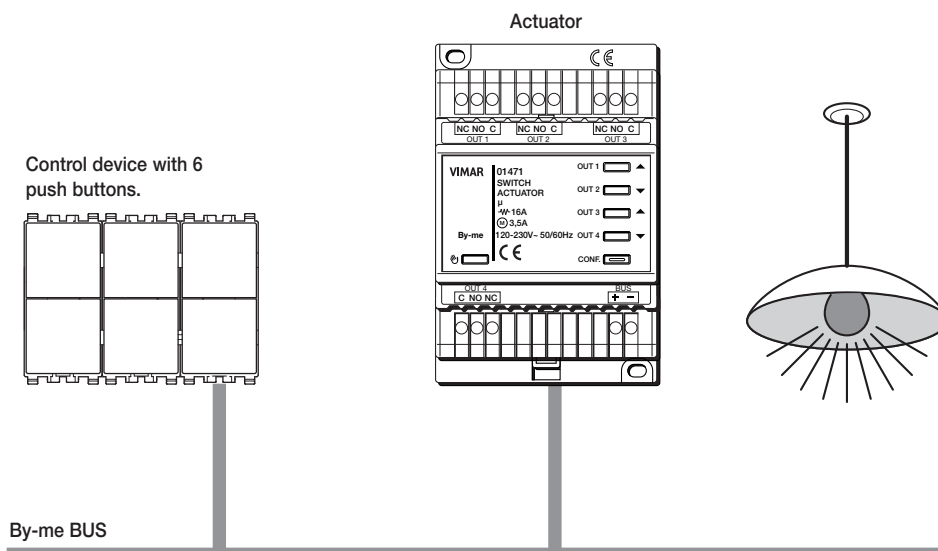

IMPORTANT:

The applications must only include homogeneous functional units: a roller shutter actuator cannot coexist with a traditional relay actuator to control the switching on of a lamp.

In order to switch a load on and off from several points, simply add extra button functional units to the application without needing to change the wiring.

Basic concepts of the By-me Plus home automation system

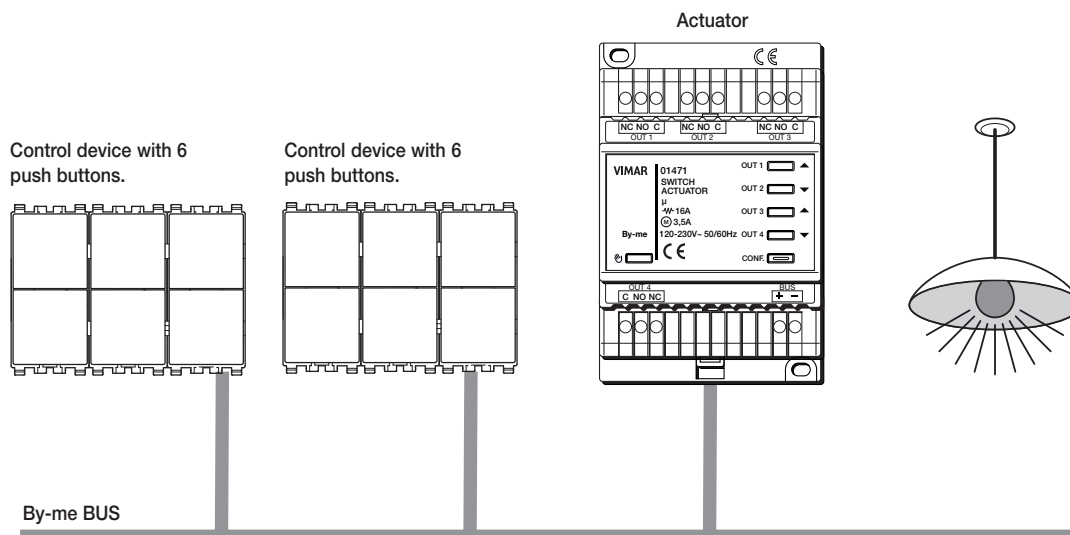

- **Scenario:** a scenario is a specific status (activated/deactivated) of the the actuators present in one or more applications that can be called up as preferred from the video touch screens (art. 01423 and 01426), from the View user App or from a button.
The scenarios are created and configured directly by the user and so this operation is not available in the View Pro App.
- **Parameters:** these can be set from the View Pro App, and are used to modify and customise the operation of each functional unit.
- **Bus line:** physical equipment used to carry electrical or electromagnetic signals paired with messages between the system devices.
- **Bus system:** set of devices and their interconnections that create applications using a common communication framework.
- **Control:** functional unit that sends control instructions and/or statuses over the bus line.
- **Actuator:** functional unit that receives control instructions and/or statuses from the bus line in order to carry out a specific action.

Each line may require one or more power supply units, depending on the number of devices and on the length of the bus. Using line couplers, a number of lines can be connected to each other, up to a maximum of 16 lines; the line couplers allow only authorised messages to pass between one line and another.

System configuration takes place via the View Pro App.

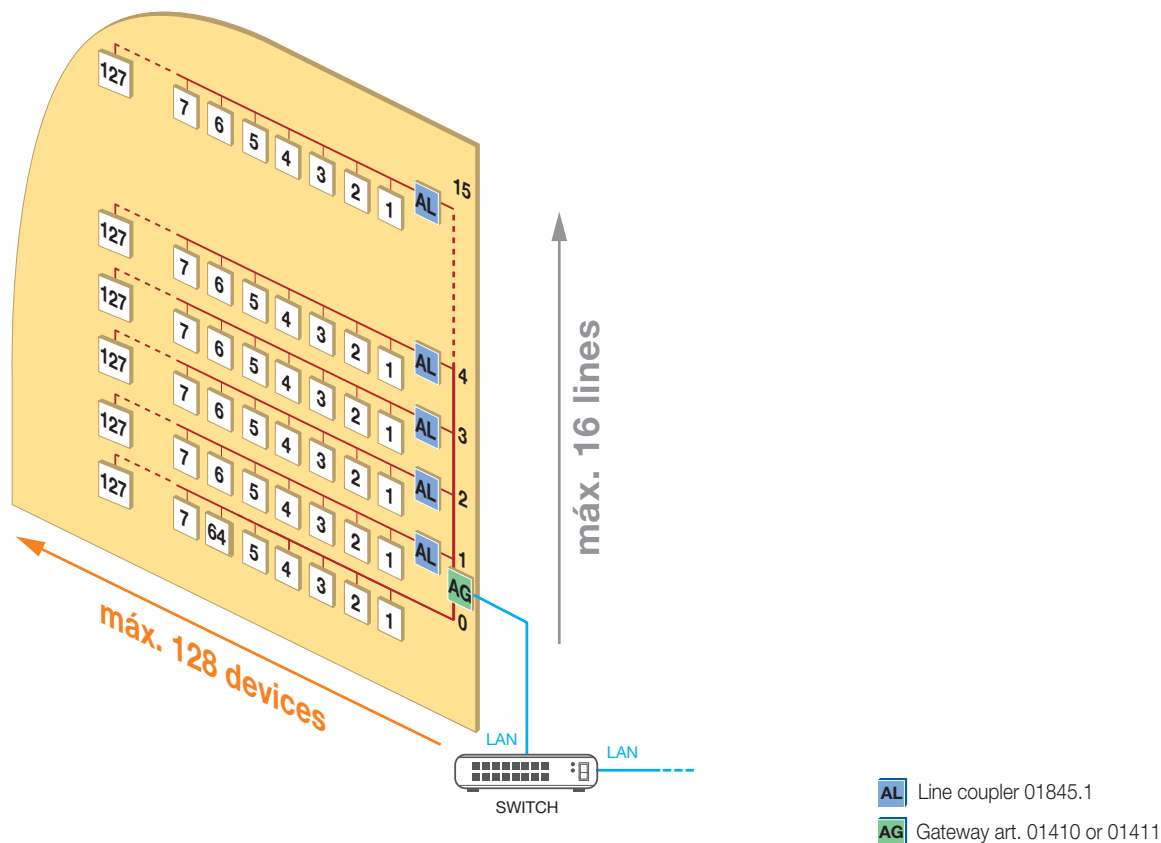

Basic concepts of the By-me Plus home automation system

CONNECTION EXAMPLE

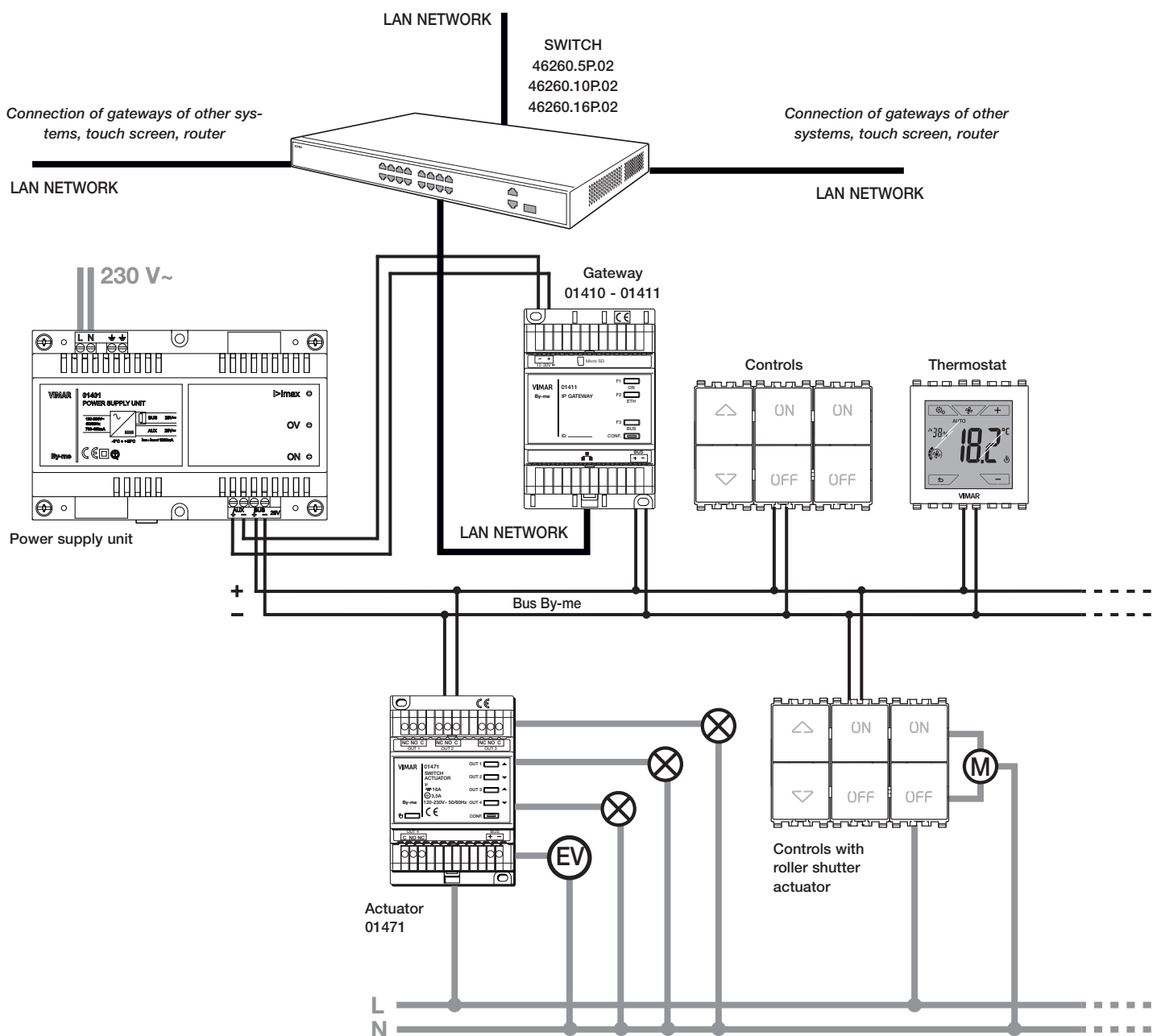

2.1 The XT platform

The XT platform stands out for its ample scalability and expandable controls; it allows you to move the front to other control devices, without requiring any wiring. It can be installed in 2-3-4 module mounting boxes and comprises:

- interchangeable front controls with 2 or 4 presses/functions;
- possibility of 4 front controls on the 3-module mounting box (up to 16 activations);
- double relay actuators (up to 4 loads per 3-module mounting box) hooking onto the back of the mounting frame and supplied via an innovative connection system;
- controls and thermostat;
- possibility of expanding and relocating functions by simply swapping modules without dismantling the lighting device (also post-installation benefits);
- matching styling between control devices and socket outlets;
- possibility of customising controls with a wide range of symbols to identify the function.

Installation topology of the By-me Plus system

3. INSTALLATION TOPOLOGY OF THE By-me Plus system

The main characteristic of the **By-me Plus** system is that all devices are connected to each other by a bus system (pair) that supplies the devices with the power and the signals carrying the digital control and monitoring data.

3.1 Bus system installation.

3.1.1 General rules and system topology.

- For the connections, use the twisted pair and sheathed cable VIMAR 01840.E (2x0.5 mm², rated voltage to earth 400 V, suitable for installation with Category I power cables). The wire pair distributes both the supply voltage (29 V d.c.) and the device control and management signals, and can be placed inside the same corrugated pipe that carries the electrical mains cables.
- A bus line must be powered with 1 or 2 power supply units 01400 or 01401. Each line can be made up of a maximum of 128 devices and a maximum of two power supply units, depending on the number of devices and on the length of the connection cable (wire pair).
- If a system is being installed with only one power supply unit and the number of devices is close to the maximum number allowed, it is advisable to plan for the installation of a second power supply unit to allow for future extensions of the system.
- The devices do not have to be connected in any particular order, maintaining the polarities indicated on the terminals. Linear type connections (figure 1), star type connections (figure 2) or mixed connections (figure 3) are possible; the rectangle in the figures represents the power supply unit. The ideal configuration is the linear type with only one power supply unit in the middle of the system or two power supply units at the ends of the bus cable.
- The total current absorbed by the various devices must not exceed the rated current of the power supply unit or units installed.
- The voltage at all points on the bus, with all devices at rest, must never go below 23 V d.c. In particular, check the points further from the power supply unit and the sections of cable where the load is greater.
- The voltage at all points on the bus, with the most numerous group of devices in operation, must never go below 23 V d.c. (check the points furthest away from the power supply unit).

1

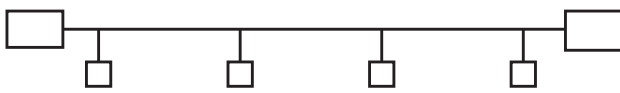

2

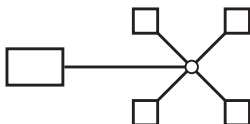

3

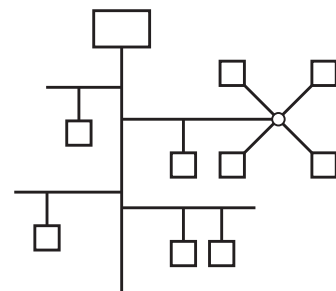

- It is essential to protect the system against the effects of lightning using surge protection devices (SPD). As a general rule, the power supply side must be protected using a Class 1 SPD downstream of the power meter, a Class 2 SPD after the RCBO circuit breaker, and a Class 3 SPD at the power supply unit input.

3.1.2 System set-up.

During the design phase, it is essential to arrange for a control unit with sufficient capacity to hold:

- traditional devices, RCBO circuit breakers, circuit-breakers, etc.;
- 1 or 2 power supply units art. 01400-01401 on DIN rail (60715 TH35);
- devices for DIN rail (60715 TH35) such as actuators for lights and roller shutters, logic unit, etc.
- surge protection devices to protect the system.

As regards the corrugated pipes for laying the Vimar 01840.E cable of the BUS line, it is advisable to plan for a dedicated raceway; it is however possible to use those where the mains electricity cables pass.

Installation topology of the By-me Plus system

3.1.3 Length of bus line: general rules.

- Maximum distance between power supply unit and device: 350 m.
- Maximum distance between devices: 700 m.
- Maximum bus cable length: 1000 m.
- Minimum distance between 2 power supply units: 40 m. It is important for the load to be well distributed between the two power supply units.
- Essential requirements:
 - the distance between two power supply units must never be less than 40 m;
 - the load must be well distributed between the two power supply units;
 - the two power supply units should be placed at the ends of one of the circuits of the system that has the largest number of devices or branches.

In any case the optimal configuration has the power supply units set as far apart as possible; this has a positive effect also on the minimum voltage on the bus.

3.1.4 Length of the BUS line.

The following is a list of maximum lengths of the BUS line installed in systems with a linear configuration (the rectangle in the figure represents the power supply unit).

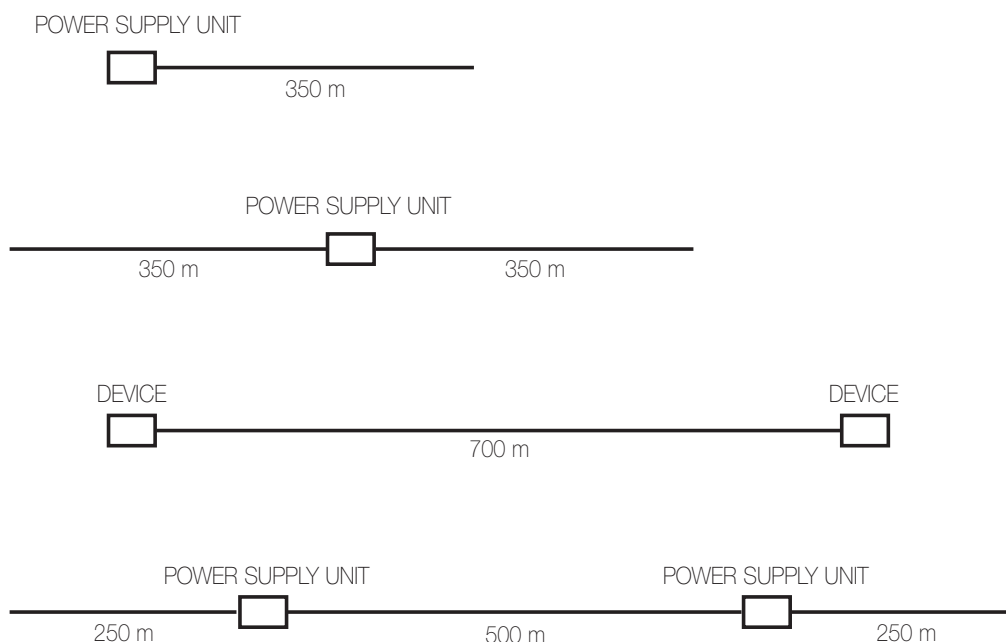

3.1.5 Bus installation: summary elements.

- **Installation and system topology:**
 - Cable of the BUS line laid in dedicated raceways; it can also be laid in the corrugated pipes that contain the electrical line.
 - Configurations allowed:
 - Linear configuration.
 - Star configuration.
 - Mixed configuration.
 - We recommend using junction boxes.
 - **For the connection use the twisted pair and sheathed cable VIMAR 01840.E** (2x0.5 mm², rated voltage to earth 400 V, suitable for installation with Category I power cables).

Installation topology of the By-me Plus system

- **Devices and distances by line**

- Logic capacity (number of devices): max 32 for art. 01410, max 300 for art. 01411
- Maximum distance between power supply unit and last device: 350 m
- Maximum total length of the bus line: 1,000 m
- Maximum distance between two devices: 700 m
- Minimum distance between two power supply units: 40 m (the loads must be balanced between the two power supply units)
- Optimal position for each single power supply unit: in the centre of the BUS line
- Optimal position for two power supply units: at the ends of the BUS line
- Minimum voltage on the furthest device: 23 V d.c. (standby)

3.2 System dimensions

The maximum number of devices that can be configured in the By-me Plus system should be calculated according to the devices configured in the system and their weight. The value of the supported device weight is shown in the following table:

Device	Weight
XT 1-module controls (art. 32021, 32023, 32024, 32031, 32033, 32034, 32044)	0.2
XT actuator (art. 32002) XT thermostat (art. 32041) and XT Multisensor (art. 32042)	1
All the other devices in the By-me Plus system	1

Gateway 01410 manages up to a maximum weight of 32 whereas gateway 01411 manages up to a max weight of 300.

The devices to count are solely those fitted with a BUS + - terminal and/or those fitted with a configuration push button (such as XT controls). The weight of power supply units and XT nodes (art. 32001) should be excluded from the calculation.

The system is configured using the View Pro App that notifies the installer of the cases in which the system is close to the product weight limits.

Configuration with View Pro App

4. CONFIGURATION WITH View Pro App

Gateways 01410-01411 are designed to carry out all operations for configuration, integration, maintenance and supervision (locally or remotely) of the By-me Plus home automation system, via IP/LAN network, Cloud and App for smartphone, tablet and PC.

The devices in the By-me Plus system are configured via App or PC in Online mode, in other words connected directly with the system.

Once you have created the system and paired the gateway (see chap. 4 of the View systems platform manual) the sequence of operations to carry out via the View Pro App is as follows:

- Defining the environments.
This should be done with care since these are the environments the end user will see on his or her App.
- From the catalogue, choose the devices (offline configuration) or enrol them directly (online configuration) in the defined environments by pressing the configuration push button once.
- Create the applications to carry out the functions required.

Note: During configuration, the View Pro App can be used in the absence of connectivity provided you logged in and entered your credentials.

4.1 Main screen of the home automation system gateway

The first time you access, the main screen will only be displayed once you have completed the operations prompted by the wizard (see para. 4.1.1).

When configuration of the environments is complete or when you select the gateway from the list of devices paired with the system, the screen containing menus is displayed; use these menus to carry out all the configuration, management, maintenance and control operations on the automation system.

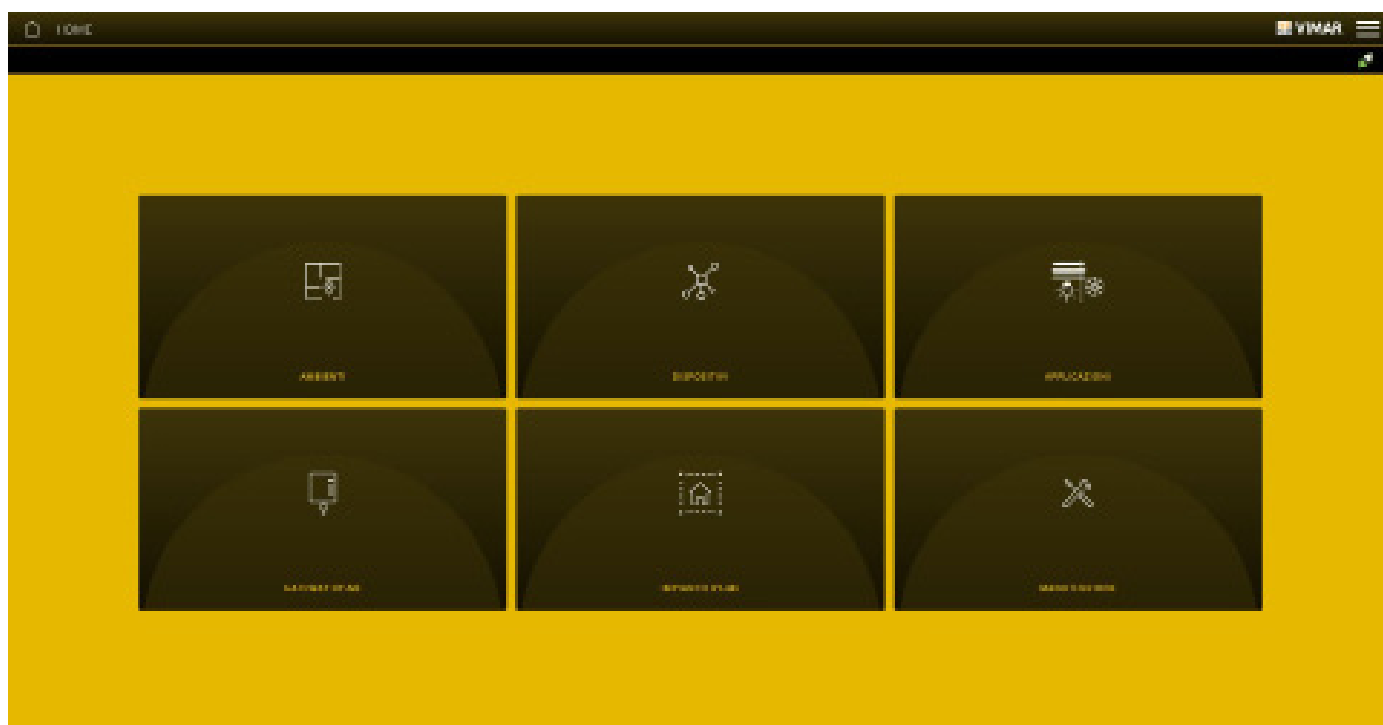

Here is an illustration of the online configuration; the push button of the device will need to be pressed the moment it is inserted in the desired environment; a dedicated screen will notify you when the push button needs to be pressed.

4.1.1 Wizard

From the screen displaying the list of all the gateways, select the home automation system one (for example **DOMOTICA Gateway Light domotica By-me**).

When you access the gateway for the first time (only and solely at the first access) the "Welcome" screen will open, prompting a sequence of all the necessary operations to create the environments in the By-me Plus system.

Select "START".

Configuration with View Pro App

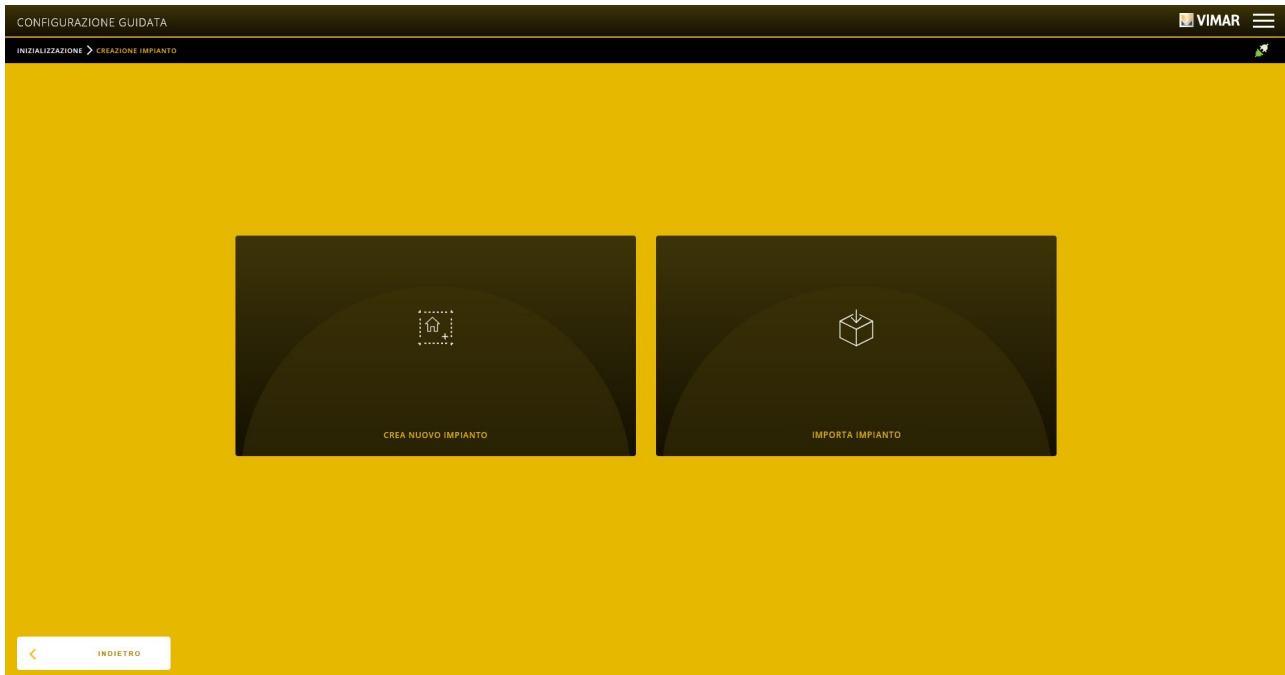

Select "CREATE NEW SYSTEM"; you will access the screen in which you should enter the numbers for the Area and Line of the By-me Plus home automation system gateway.

The "IMPORT SYSTEM FROM BACKUP" option is used to restore an existing system (y loading the backup) following the replacement of a malfunctioning gateway or during the cloning process of several identical systems.



N.B.: "Group offset" is the hexadecimal value that represents the first group address of the set of addresses used by the gateway to configure By-me Plus devices on the field. The "Longitude" and "Latitude" items allow you to enter the position coordinates to use the astronomical clock function.

Once you have entered the Area and Line of the gateway select "CONTINUE"; the page displayed is for the creation of environments in which the By-me Plus system will be distributed (for instance, kitchen, living room, bedrooms, etc.).

Configuration with View Pro App

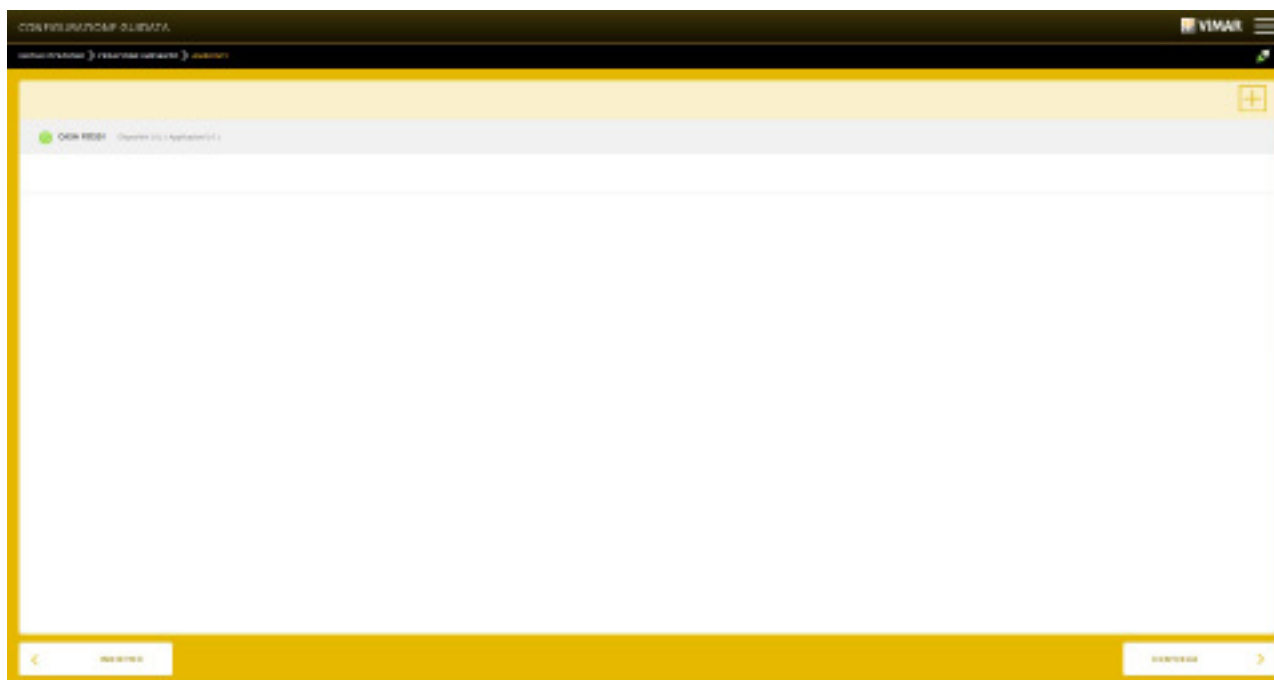

To add the environment, click on , name it and then click on "ADD".

IMPORTANT: WE ADVISE YOU TO CARRY OUT THIS OPERATION WITH EXTREME CARE SINCE THE ENVIRONMENTS CREATED WILL THEN BE DISPLAYED IN THE SAME WAY IN THE USER'S VIEW APP.

Now the creation of environments is complete, click on "CONTINUE" (the App will display the "Configuration Complete" confirmation screen) then click on "END" to view the main screen.

After the first access to the App the wizard will no longer be active and so the creation of new environments will have to be done using the ENVIRONMENTS menu.

4.2 Device enrolment

The DEVICES menu allows you to enrol all the devices in the By-me Plus system and all the KNX standard products belonging to third-party systems; it is also designed to integrate burglar alarm system and video door entry system devices into the By-me applications in order to achieve combined functions such as, for instance, switching on a light after a presence has been detected by an IR sensor in the burglar alarm system, opening the electrical lock on the gate via a home automation system button, etc. It also allows the enrolment of EnOcean interfaces art. 20508-19508-14508 to integrate into the By-me Plus system those EnOcean radio frequency devices which make it possible to perform the basic automation functions (control lights and roller shutters, scenarios, etc.) through the configurable radio buttons such as rockers, dimmers, roller shutter control and scenarios and radio relay actuators.

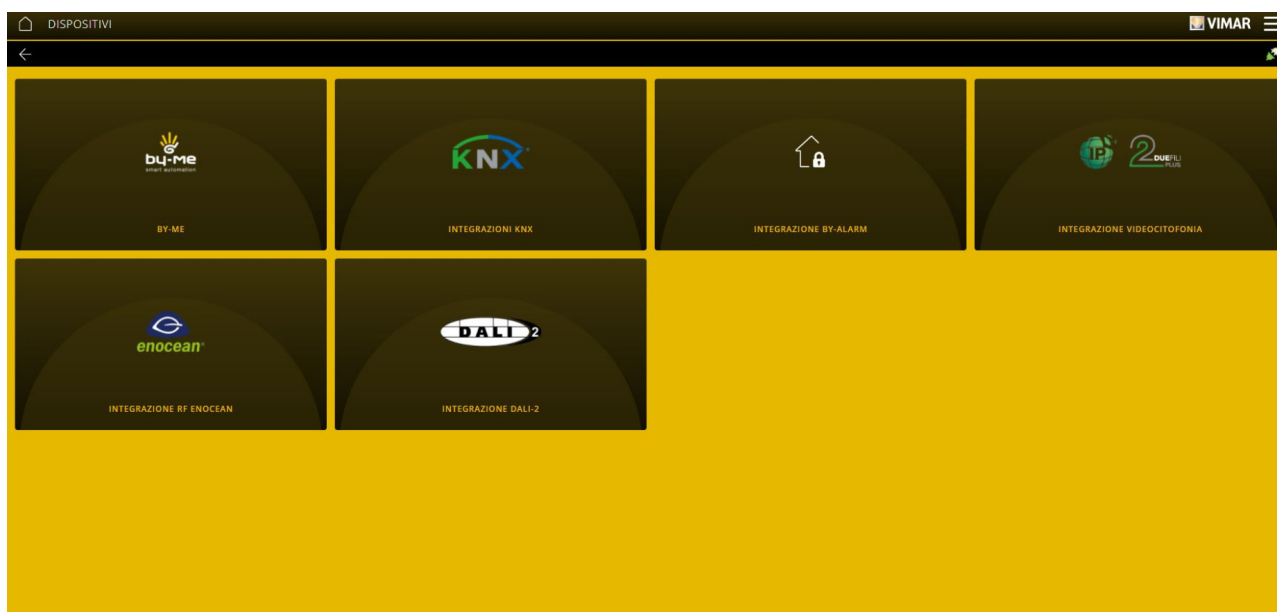

Configuration with View Pro App

4.2.1 By-me DEVICES

The enrolment procedure is similar for all the devices in the system, whether these are control devices for lights and roller shutters, sound system, temperature control, energy management, EnOcean interfaces, DALI/DALI-2 actuators, XT platform devices, etc.

Two different types of enrolment are available:

- **Enrolment via bus:** use this mode when the By-me Plus devices are already connected to the bus.
- **Enrolment via catalogue:** a mode that allows for "virtual" configuration without the presence of physical devices, postponing the bus enrolment operations to a later stage.



4.2.1.1 Enrolment VIA BUS

In this mode, it is necessary to perform the one-by-one learning process for the By-me Plus devices physically connected to the bus. Upon completion of the enrolment procedure, it will be possible to proceed with the creation of applications, which will be immediately functional.

4.2.1.1.1 Devices

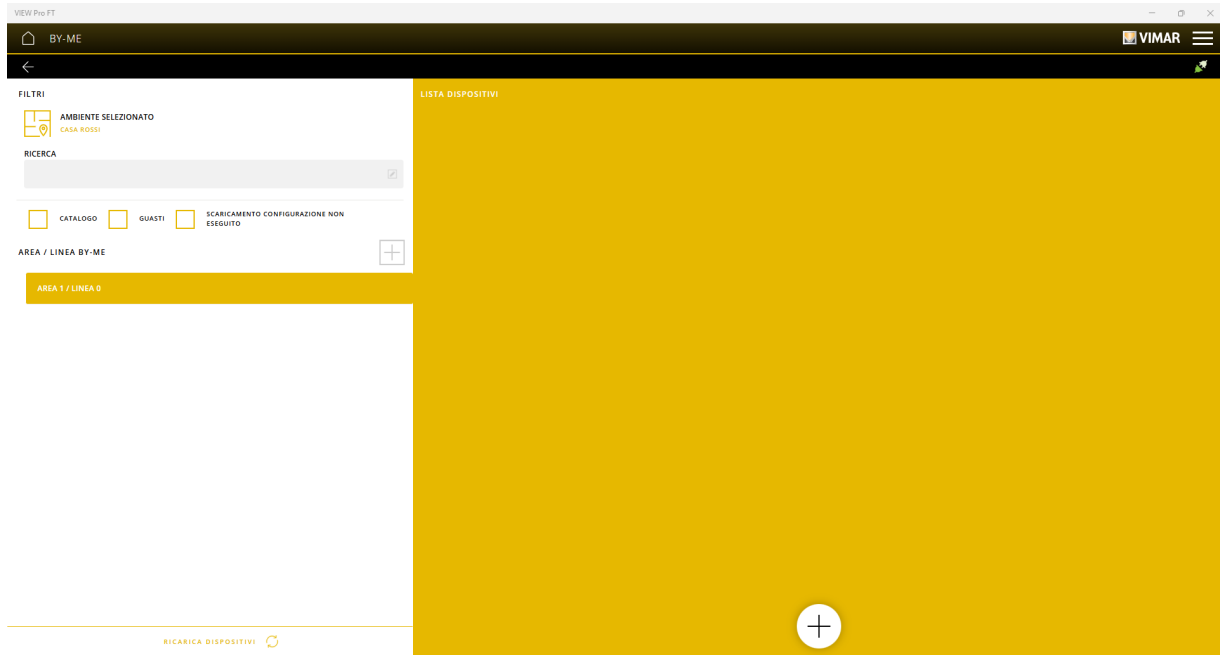
To perform the procedure, select the menu: DEVICES -> BY-ME; a screen appears allowing you to enrol the By-me devices in the previously created environments.



Click on  to select the desired environment and click on .

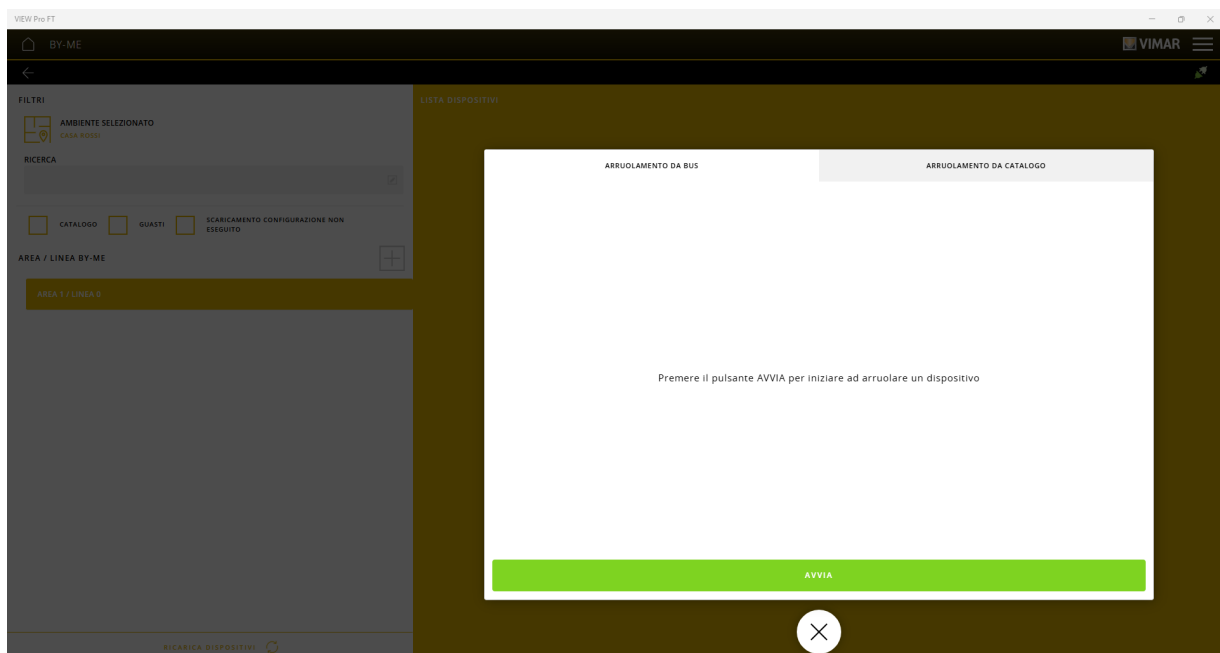

Select "ENROLMENT VIA BUS and click on "START".

Configuration with View Pro App

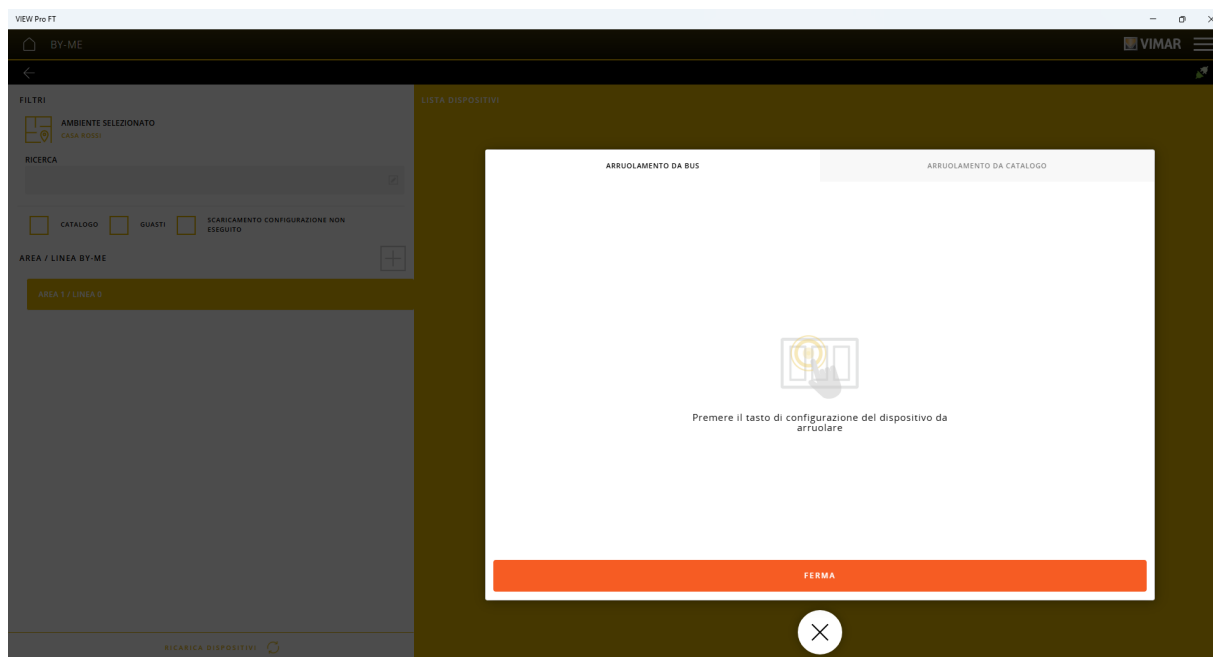

Then press the configuration push button on the device to enrol in the environment.

IMPORTANT: To enrol the buttons of the home automation system controls, hold down the configuration push button and any button immediately thereafter.

Examples:

- Control device with six push buttons and change-over relay output: when prompted by the App (screen on previous page) press the configuration push button and then any other button.

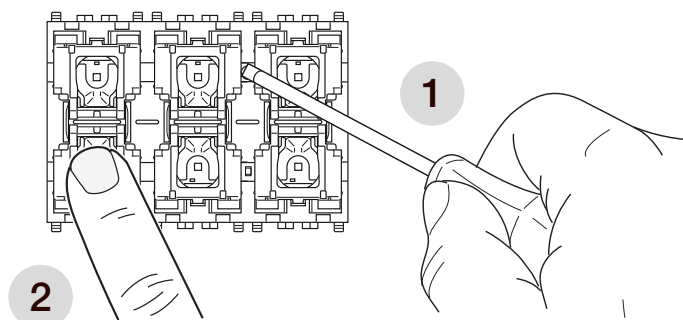

- Multi-function home automation system actuator with 4 relay outputs: when prompted by the App, press the CONF push button once.

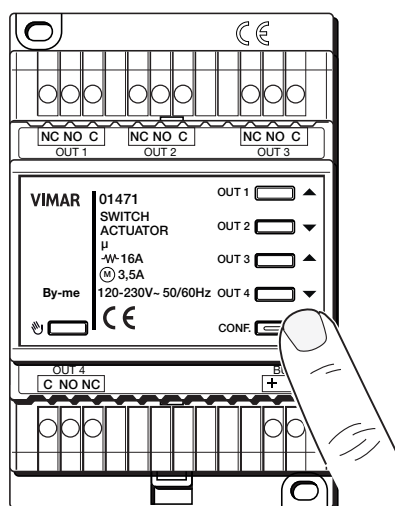

Configuration with View Pro App

- Thermostat art. 02951: when prompted by the App, press simultaneously (with quick press) the areas of the display shown in the figure below.

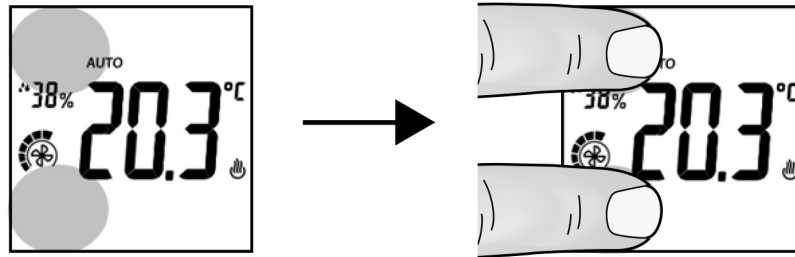

The backlighting becomes red and the display shows **CnF** (configuration).

- Thermostats art. 30471-02971 and 21514: when the App prompts you to, press the keys shown in the following table simultaneously (press quickly).

	Article	Keys to be pressed simultaneously
30471 02971		
21514.F		
21514.S		
21514.H		

The backlighting becomes red and the display shows **CnF** (configuration).

Configuration with View Pro App

- Retrofit modules: when prompted by the App press the CONF push button once.

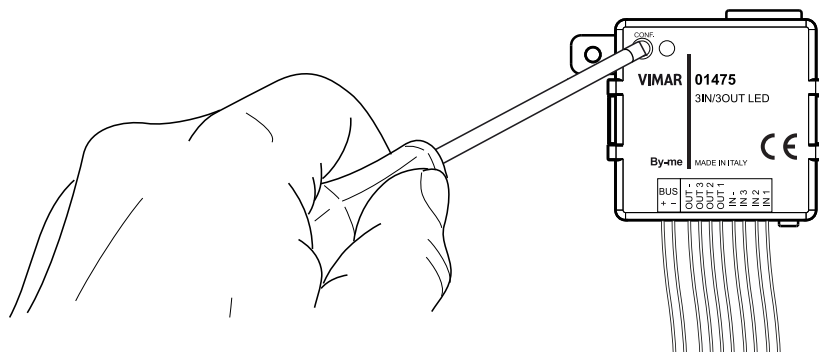

- XT platform devices: when the App prompts you to, press the configuration push button.

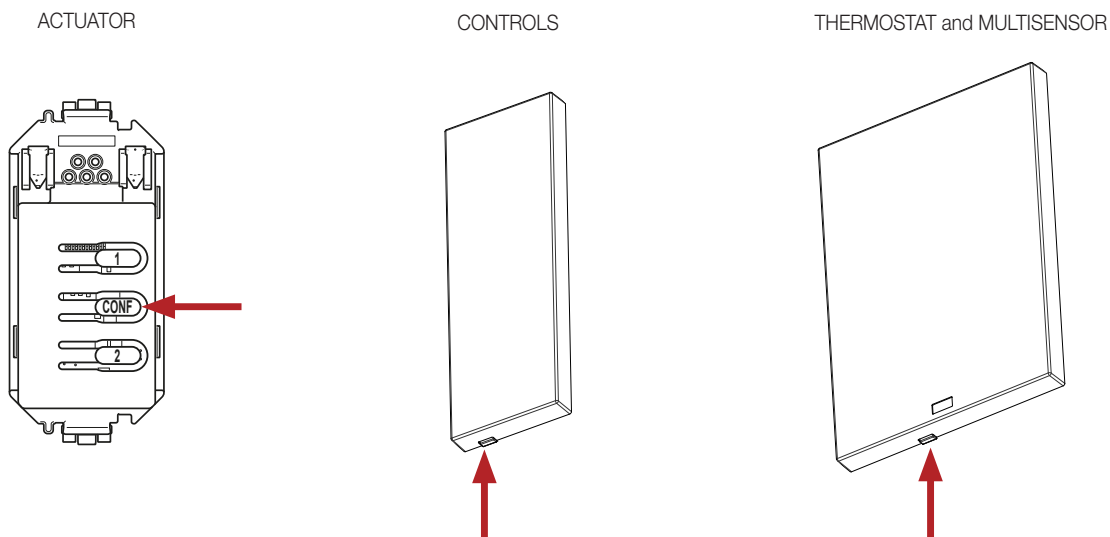

At the end of each enrolment, a screen is displayed allowing you to modify the environment in which the device is enrolled if necessary (click on ).

Configuration with View Pro App

In the following example, the Module with 9 inputs and 8 outputs 01470.1 was enrolled

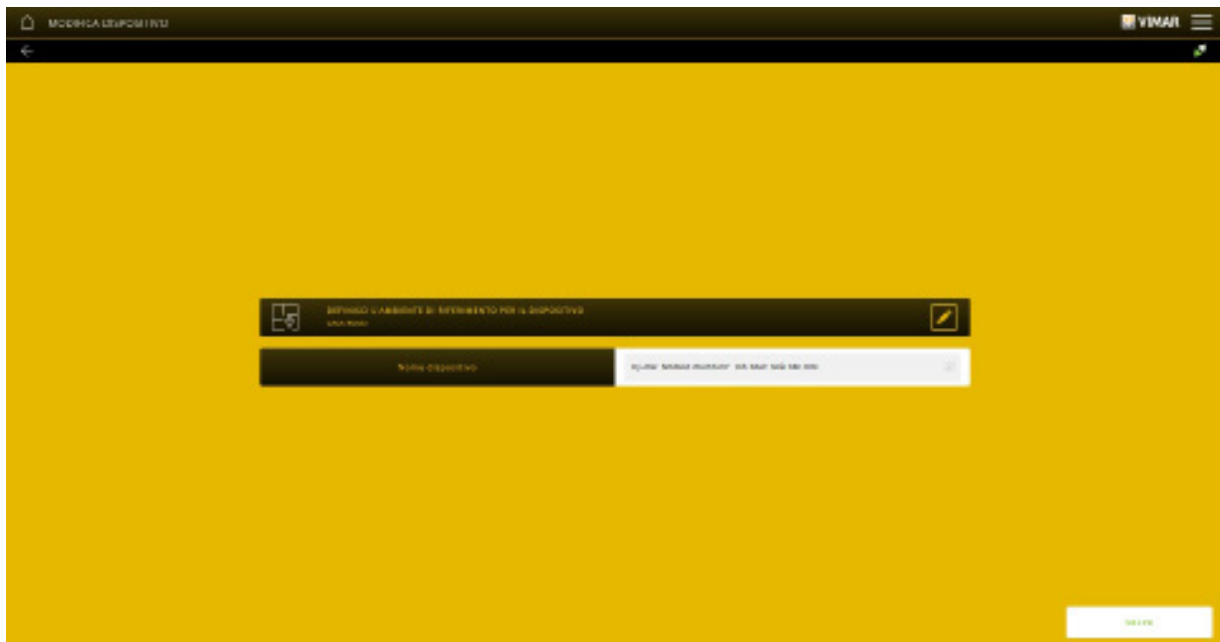

Click on "SAVE"; the screen displayed shows the functional units making up the enrolled device (which must subsequently be paired with the application that carries out the desired function).

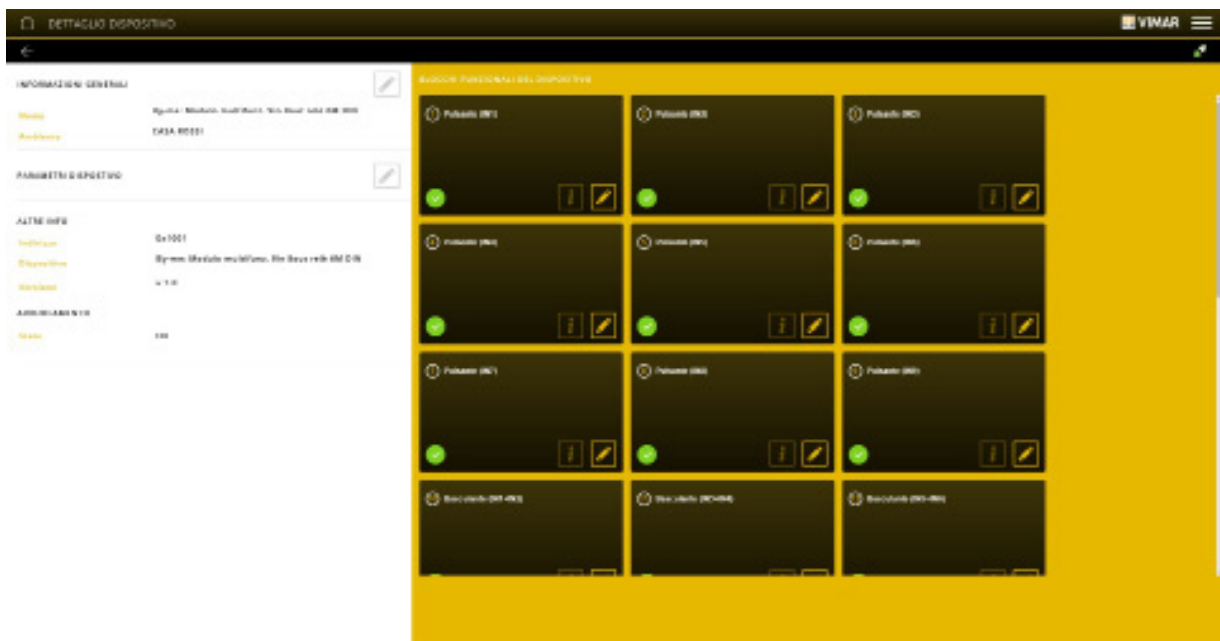



The procedure described above should be carried out for each device that needs to be enrolled.

Configuration with View Pro App

4.2.1.1.2 Line coupler

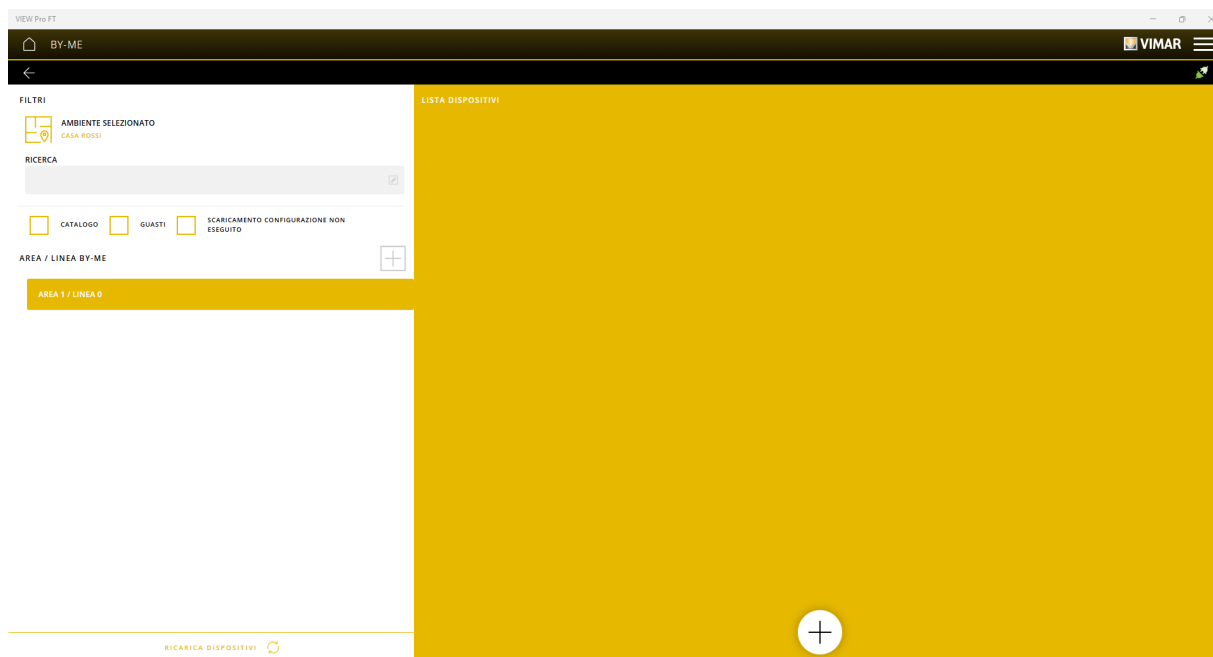
Select the menu: DEVICES -> BY-ME; for the line coupler too, a screen appears allowing you to enrol the By-me devices in the previously created environments.



Click on  to select the desired environment and click on  opposite BY-ME AREA / LINE

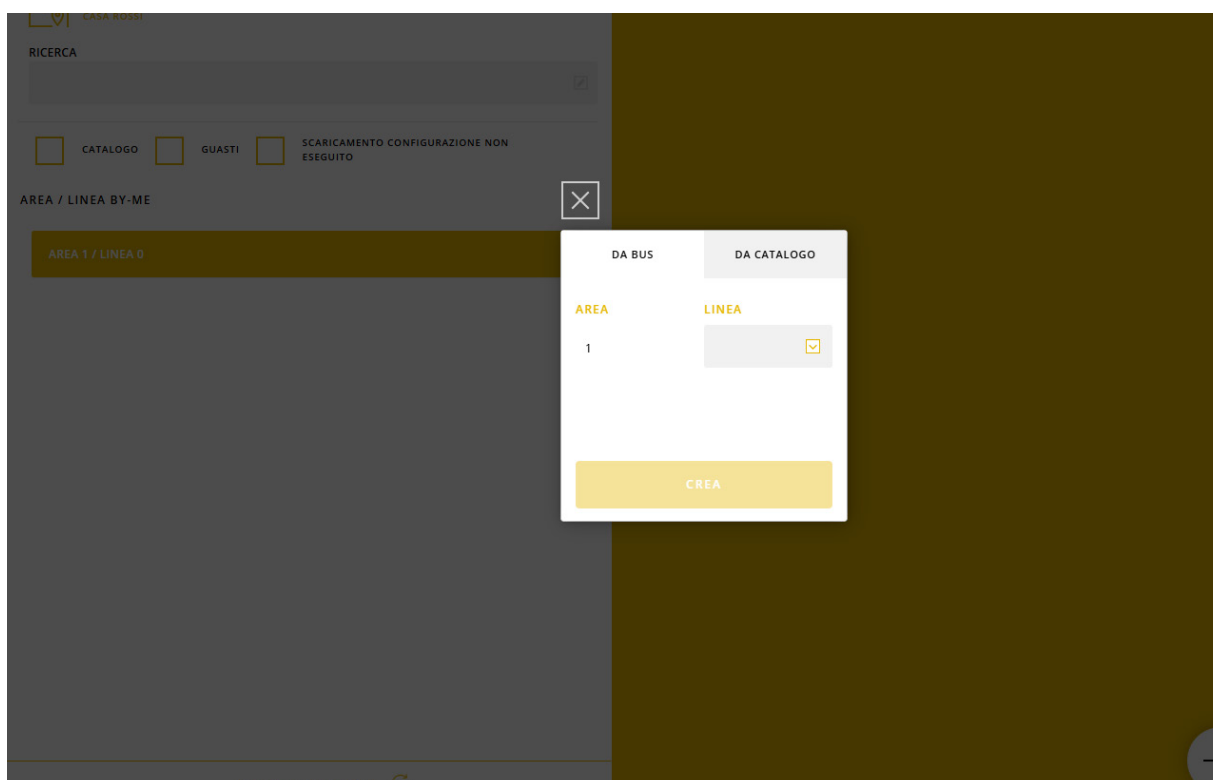

Select VIA BUS and insert the line number on which to enrol the device; next, click on "CREATE".

Then press the configuration push button of the line coupler (indicated with the letter L in the instruction sheet for art. 01845.1).

At this point the procedure is the same as for the By-me devices; click on "SAVE" to display the details page of the device you just enrolled and synchronise the line coupler by clicking on .

NOTE: It is necessary to synchronise the line coupler whenever functional units relating to devices downstream of the line coupler itself are added or removed.

Configuration with View Pro App

4.2.1.2 Enrolment VIA CATALOGUE



In this mode, it is possible to carry out a "virtual" configuration, meaning without having the By-me Plus devices physically available and/or without having them wired to the bus. This approach is useful for designing the system in advance and/or for extending it when the necessary devices are not immediately available.

Upon completion of the enrolment procedure, it will be possible to proceed with the creation of applications, which will however not be functional. After completing the wiring of all devices, it will be necessary to perform a learning and configuration download procedure for each one; at the end of this process, the system will be fully operational and functional.

4.2.1.2.1 Devices

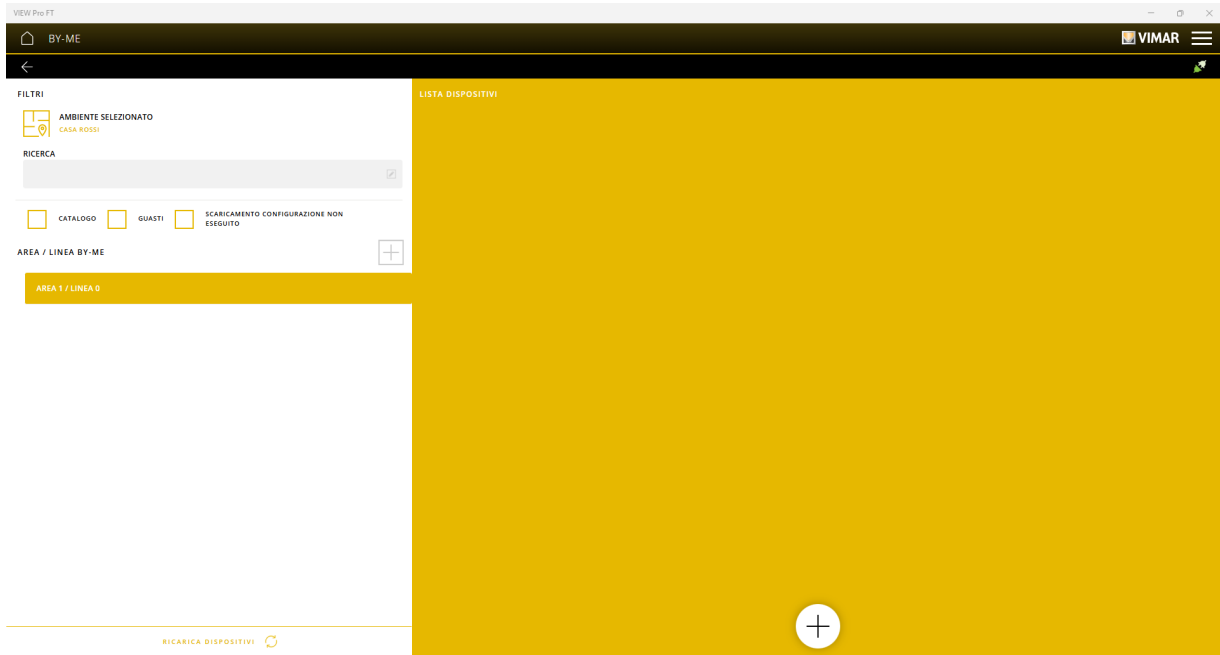
To perform the procedure, select the menu: DEVICES -> BY-ME; a screen appears allowing you to enrol the By-me devices in the previously created environments.



Click on  to select the desired environment and click on .

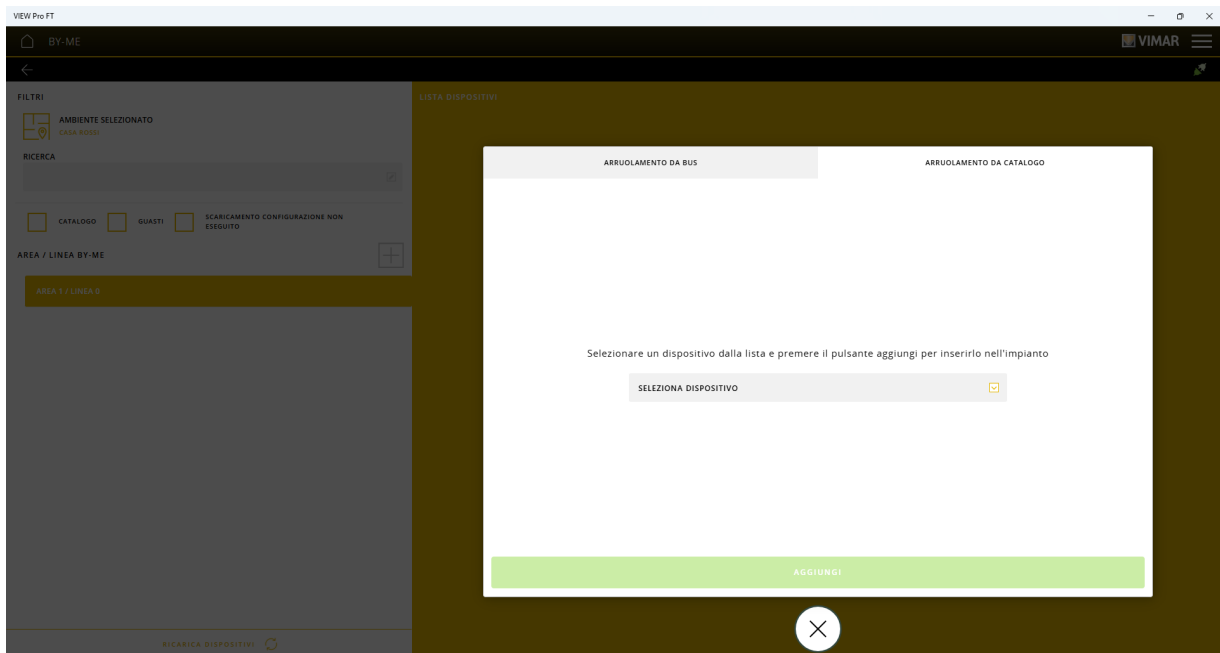

Select "ENROLMENT VIA CATALOGUE and click on "ADD".

NOTE: The search for the device type can be carried out based on the article name and/or its code (or part of them). Article codes are displayed without the colour component (for example, article 02971.N is shown as 02971).

Configuration with View Pro App

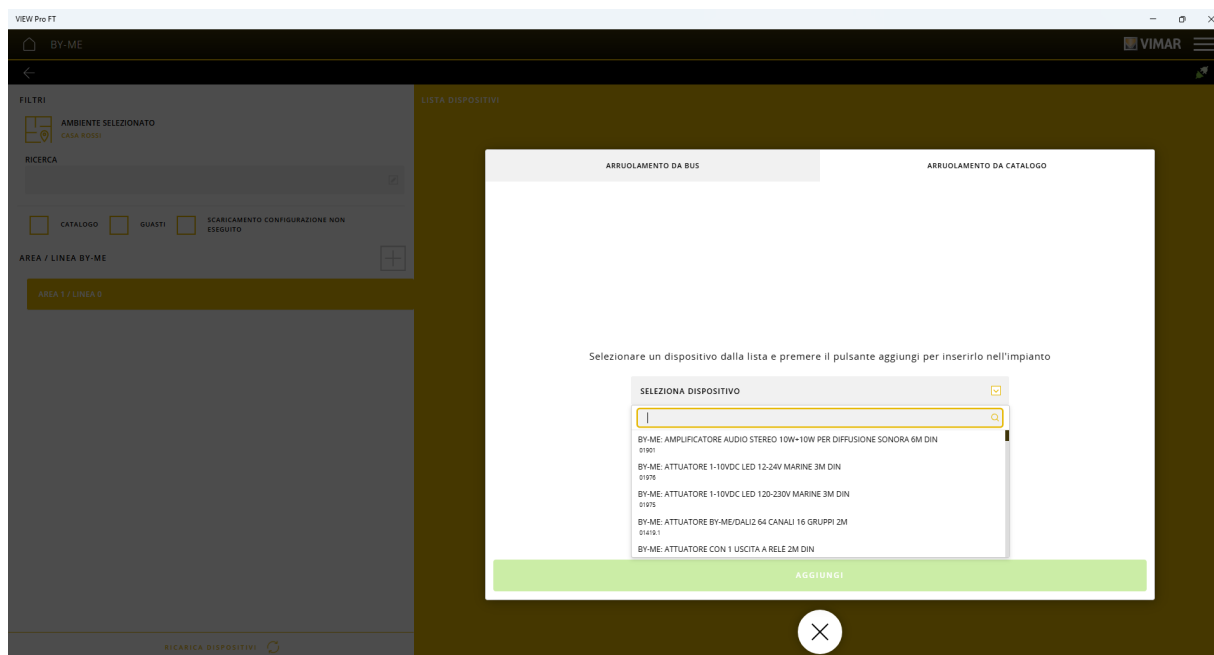

At the end of the procedure, a screen is displayed allowing you to modify the environment in which the device is enrolled if necessary; to do this, click on .

In the following example, the Module with 9 inputs and 8 outputs 01470.1 was enrolled

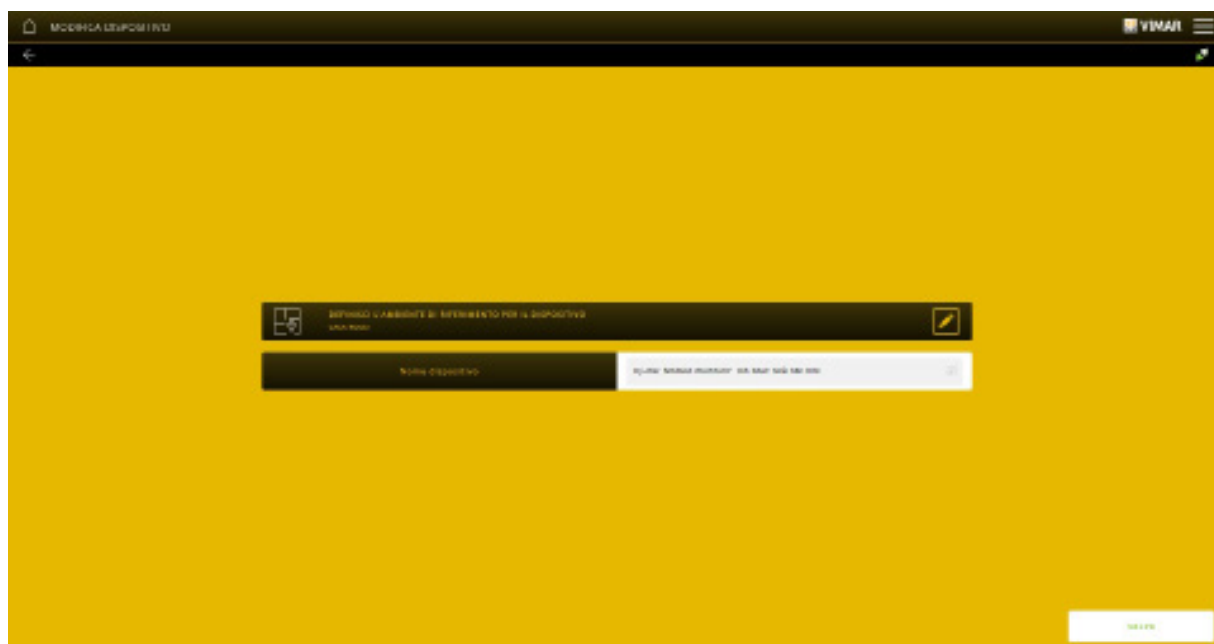

Configuration with View Pro App

Click on "SAVE"; the screen displayed shows the functional units making up the enrolled device (which must subsequently be paired with the application that carries out the desired function).

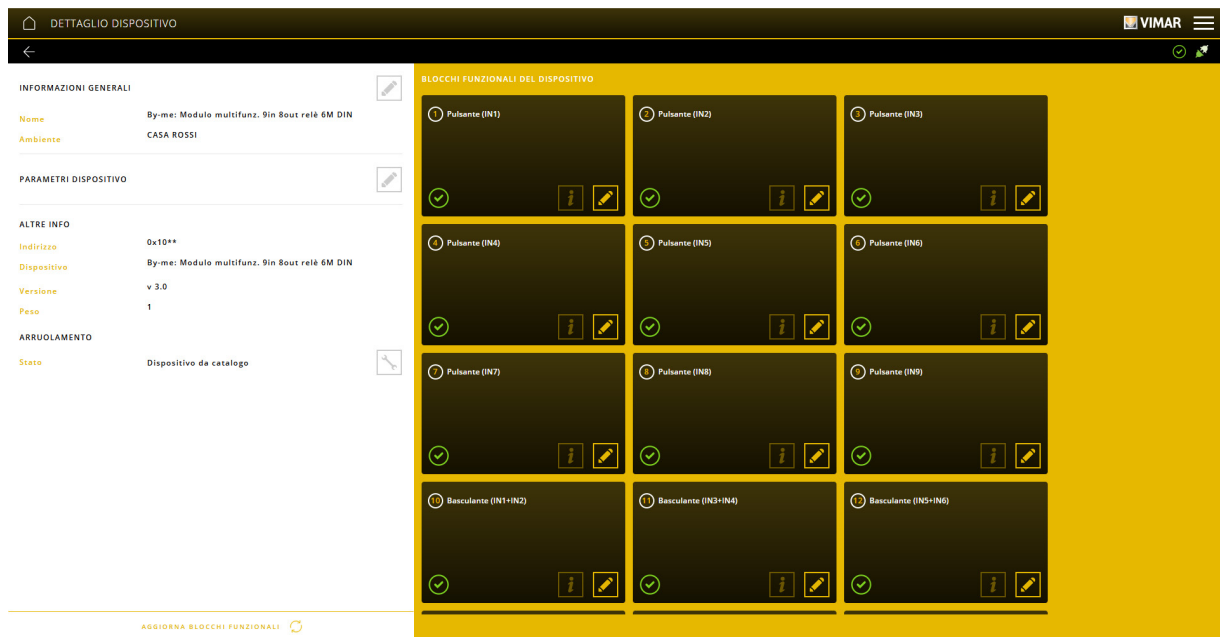

The procedure described above should be carried out for each device that needs to be enrolled.

4.2.1.2.2 Line coupler

Select the menu: DEVICES -> BY-ME; for the line coupler too, a screen appears allowing you to enrol the By-me devices in the previously created environments.

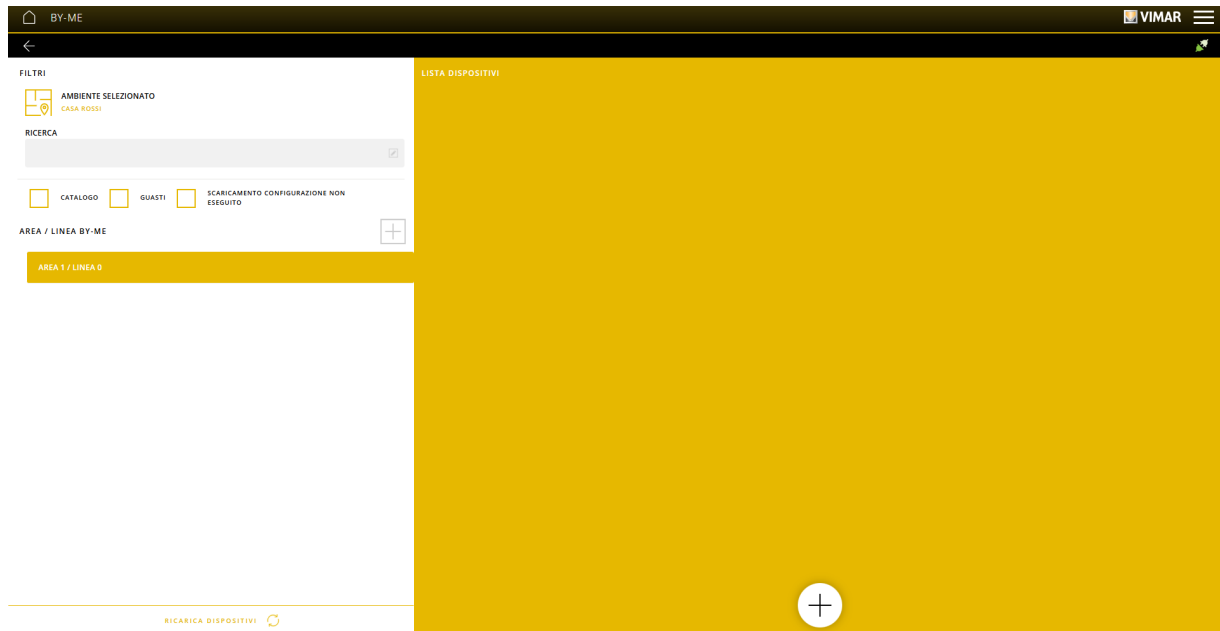

Click on to select the desired environment and click on opposite BY-ME AREA / LINE

Configuration with View Pro App

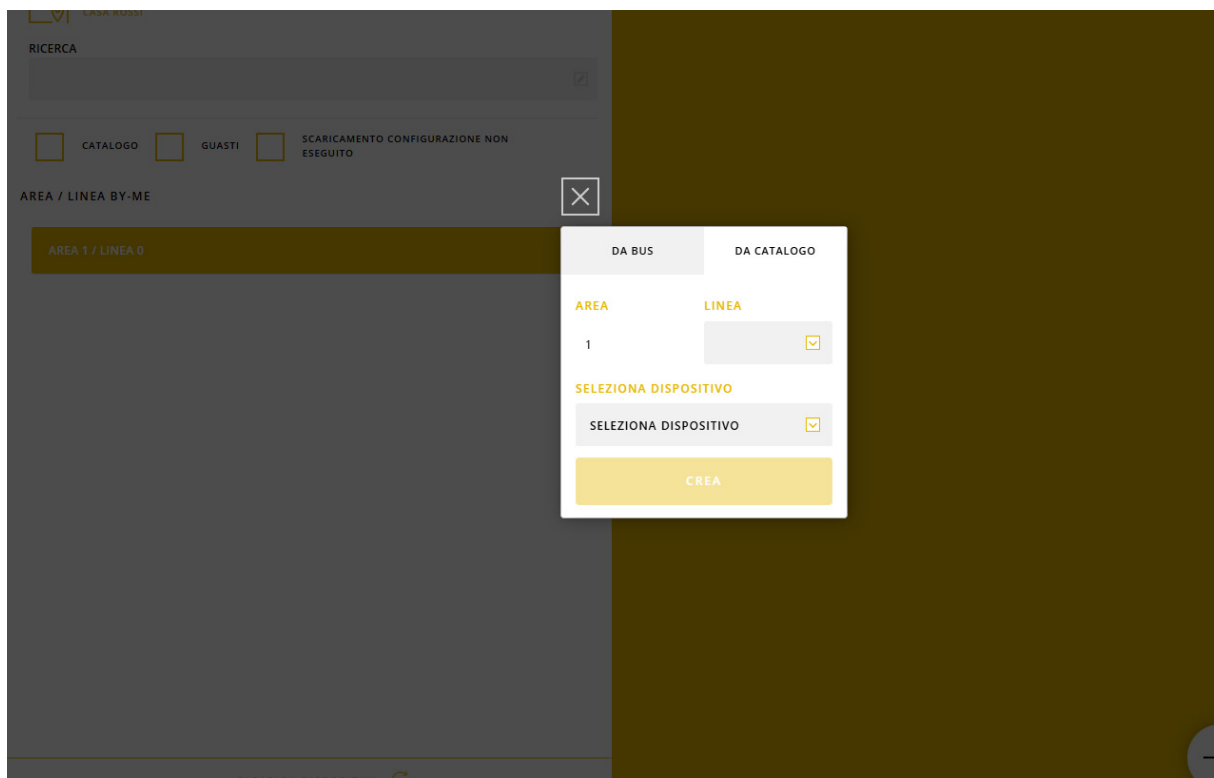

Select VIA CATALOGUE and insert the line number on which to enrol the device; next, click on "CREATE".

At this point the procedure is the same as for the By-me devices; click on "SAVE" to display the details page of the device you just enrolled.

NOTE: For a line coupler enrolled via catalogue, the synchronisation operation cannot be performed; this must instead be carried out after the association procedure.

4.2.1.3 List of By-me Plus devices

All enrolled devices (both VIA BUS and VIA CATALOGUE) are visible on the DEVICES -> BY-ME page, organised by their respective lines. Each device enrolled will be represented as in the example below:

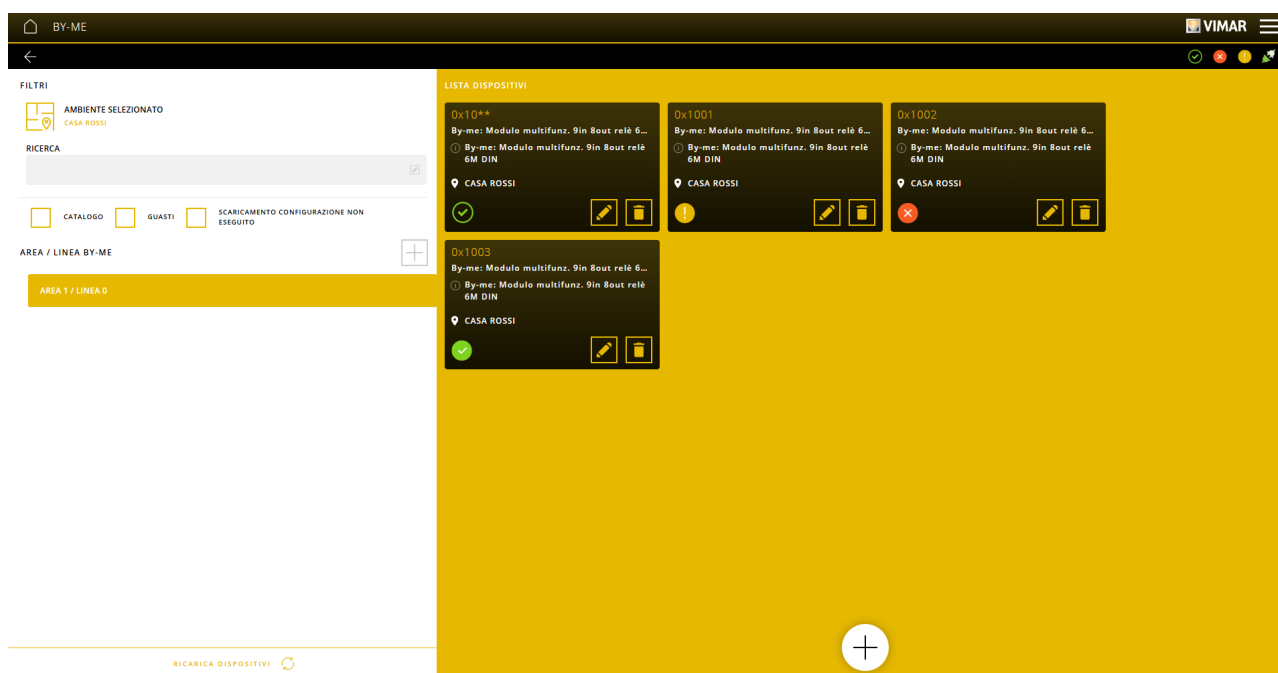

Configuration with View Pro App

Every enrolled device is identified by a box containing the following information:

- The physical address assigned to the device if it was enrolled via the BUS; for enrolment VIA CATALOGUE, the last two digits of the address (as they are not yet defined) are replaced by the * character
- The name previously assigned to the device
- The model name of the device
- The environment in which the device was enrolled
- The device status icon, which may take the forms shown in the table below:

Icon	Meaning
	The device is enrolled via the bus and correctly configured
	The device is enrolled via the catalogue
	The device is enrolled via the bus and is currently being configured
	The device is enrolled via the bus and a configuration error is present
	The device is enrolled via the bus and has been reported as faulty during a diagnostic check

Clicking "RELOAD DEVICES" refreshes the page and updates the status icons.

Click on to display the detailed screen of the specific device.

Click on to delete the device.

4.2.1.4 Detail of By-me Plus devices

The detail page of a By-me Plus device is displayed upon completion of the enrolment procedure (both VIA BUS and CATALOGUE) and/or by using the button in the DEVICES -> BY-ME section.

The functional units that make up the device are displayed in the central section of the page, represented as follows:

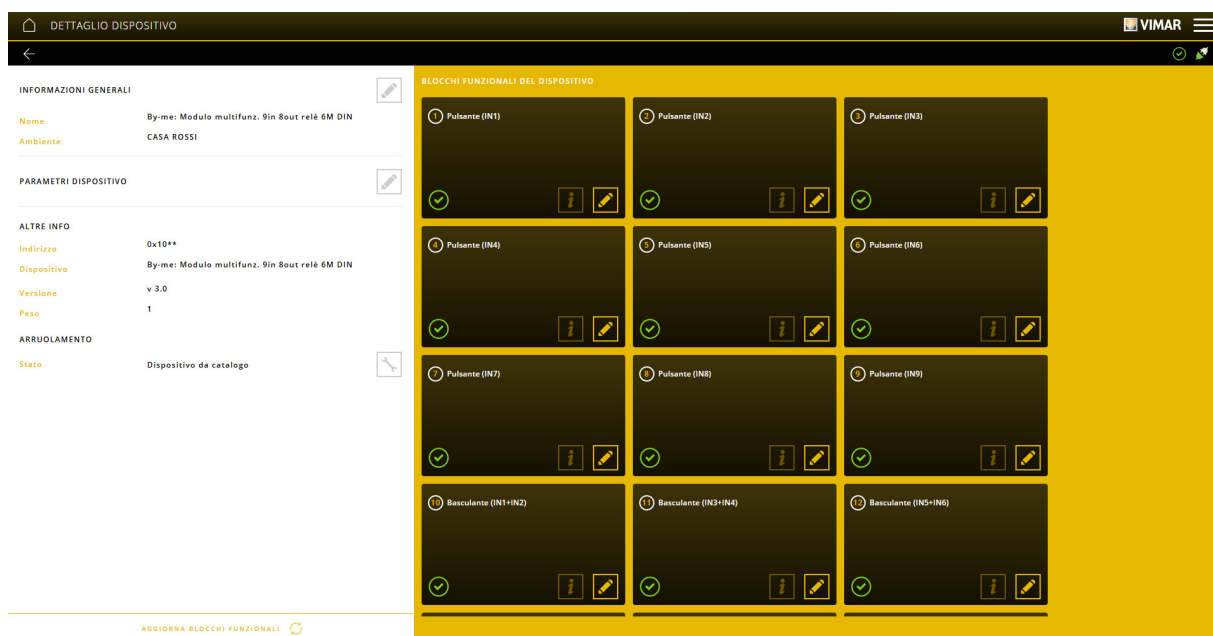

The box representing the functional unit displays the following information:

- The index and the name associated with the functional unit
- The status icon of the functional unit, which can indicate the same statuses as the devices, with the exception of the "faulty" status

Select to display, after configuration, the applications in which the functional unit is used.

Configuration with View Pro App

Click on  to rename the functional unit itself:



Click on  to save the new name or click on  to cancel the change made.

Click on  to restore the original name of the functional unit.

The following operations can be carried out in the left section of the page:

- Modify the name of the environment and/or device, by clicking on  in the GENERAL INFORMATION section
- Consult and/or modify the device parameters, by clicking on  in the DEVICE PARAMETERS section
- Perform the configuration/maintenance operations depending on the status of the device (see the ENROLMENT section)

Clicking on "UPDATE FUNCTIONAL UNITS"  refreshes the page and updates the status icons.

Replacement procedure

If the device is in faulty status () , click on  in the ENROLMENT section to launch the device replacement procedure.

Remove the faulty device and connect the new one in its place; the App will display the screen allowing you to enrol the new device and maintain all the settings of the previous one.

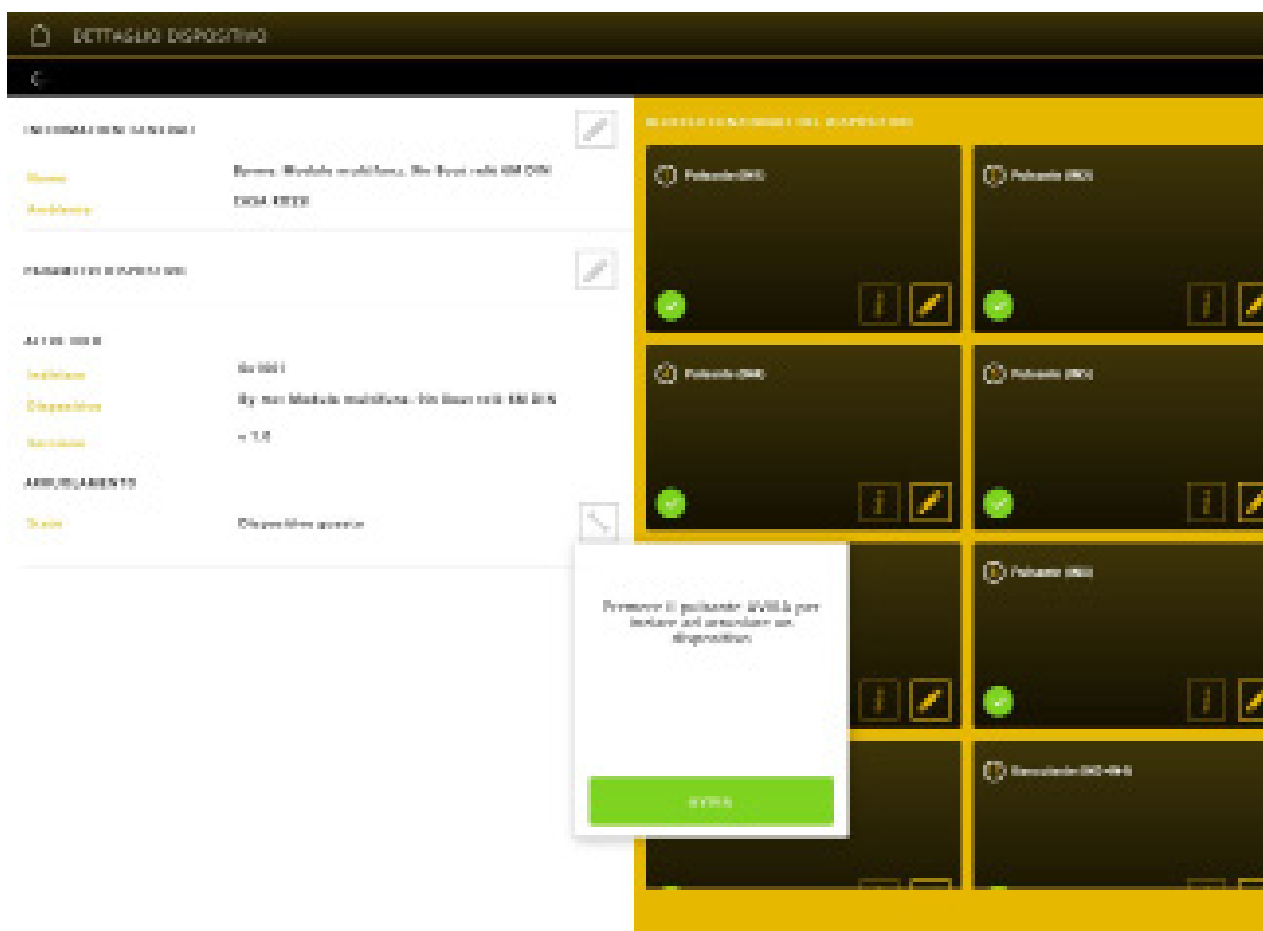

Click on "START".

Caution: In the event that an EnOcean interface proves faulty, the replacement cannot be performed with the procedure illustrated above; you will therefore need to remove the faulty interface, enrol a new one and repeat the association of all the EnOcean devices paired with it.

Configuration with View Pro App

Realignment procedure

If the device is in configuration error status (), click on  in the ENROLMENT section to launch the device configuration realignment procedure.

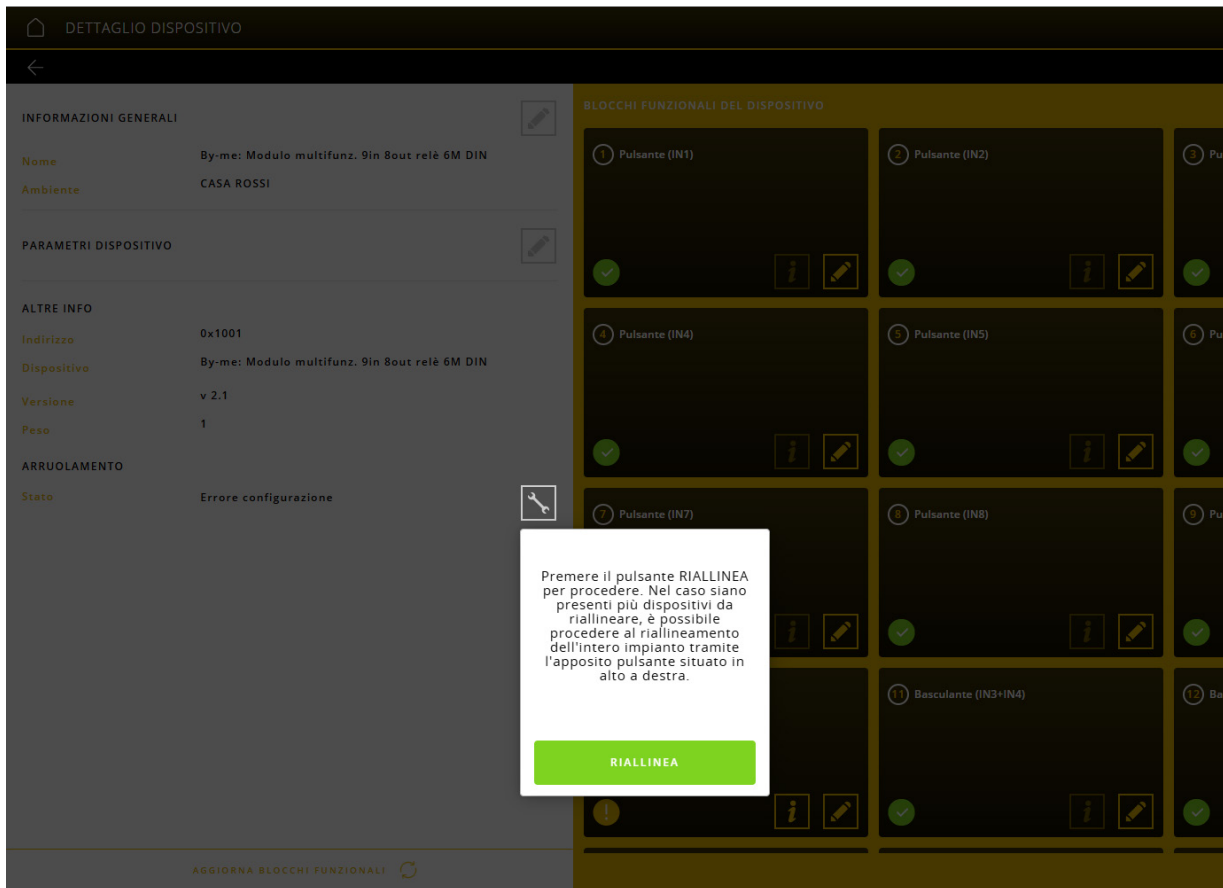

Click on "REALIGN" to launch the procedure.

NOTE: Click on the  push button at the top right to perform the global realignment of all the devices in the system requiring it.

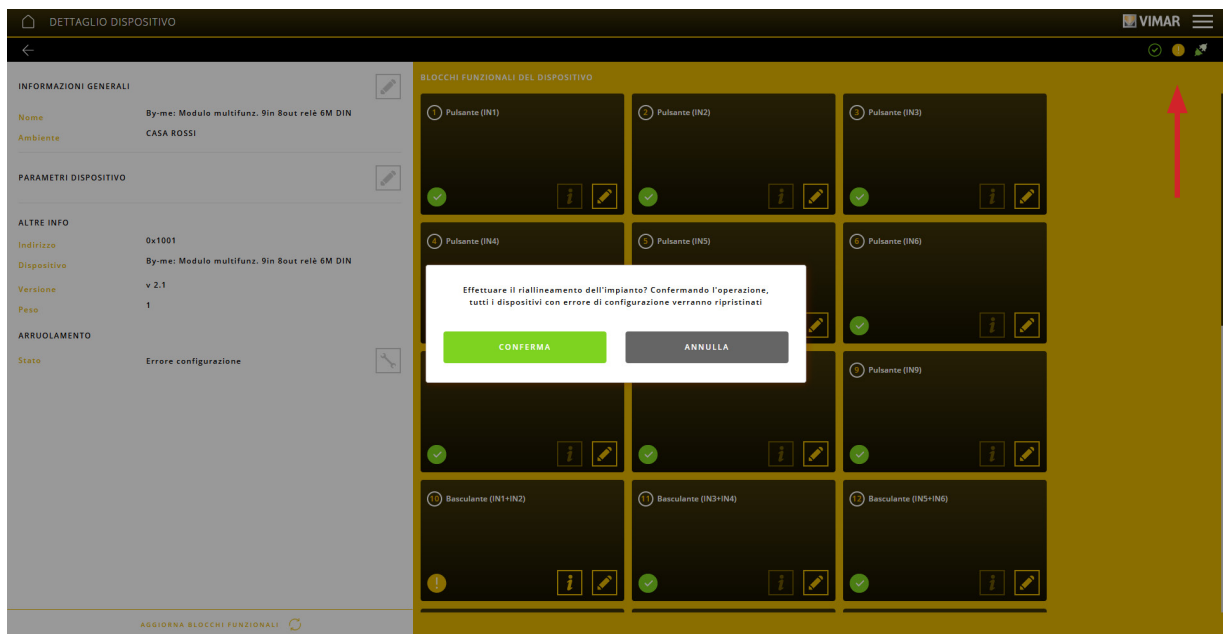

Clicking on "UPDATE FUNCTIONAL UNITS"  refreshes the page and updates the status icons.

Configuration with View Pro App

Device enrolment via catalogue procedure

If the device is in device via catalogue status (), click on  in the ENROLMENT section to launch the device enrolment from catalogue procedure.

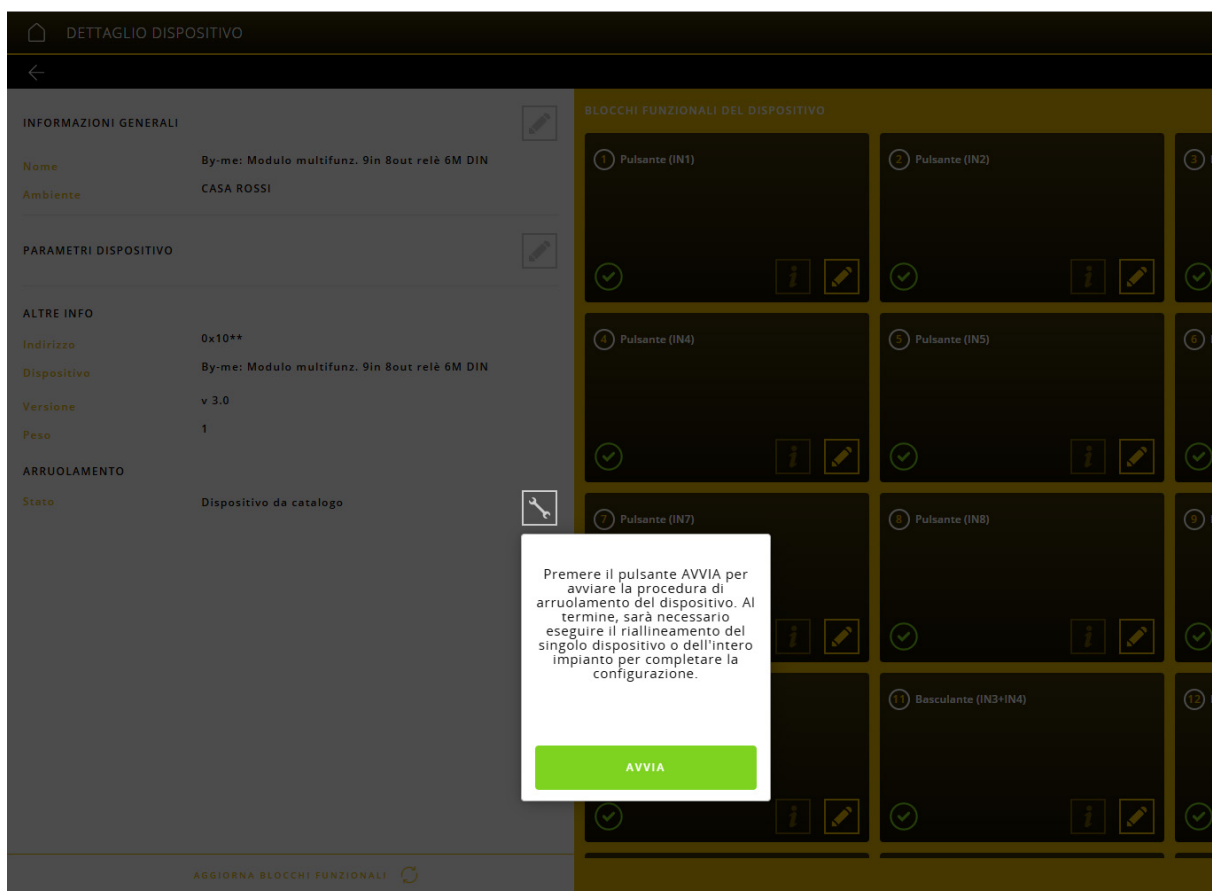

Make sure the device is physically connected to the bus and click on START.

At the end of the procedure, if configured in at least one application, the device will be marked with the configuration error status () and the realignment procedure described above will therefore be necessary.

NOTE: In the case of multiple devices VIA CATALOGUE, proceed by enrolling each one of these first and then perform the global realignment procedure described above.

Configuration with View Pro App

4.2.2 KNX DEVICES

Select KNX INTEGRATIONS to display the screen allowing you to enrol the KNX devices in the By-me Plus system.

4.2.2.1 VIRTUAL KNX DEVICES

Allows you to enrol the devices of third-party systems through virtual datapoints.

Select "VIRTUAL KNX DEVICES" then to enrol the device in the selected environment.

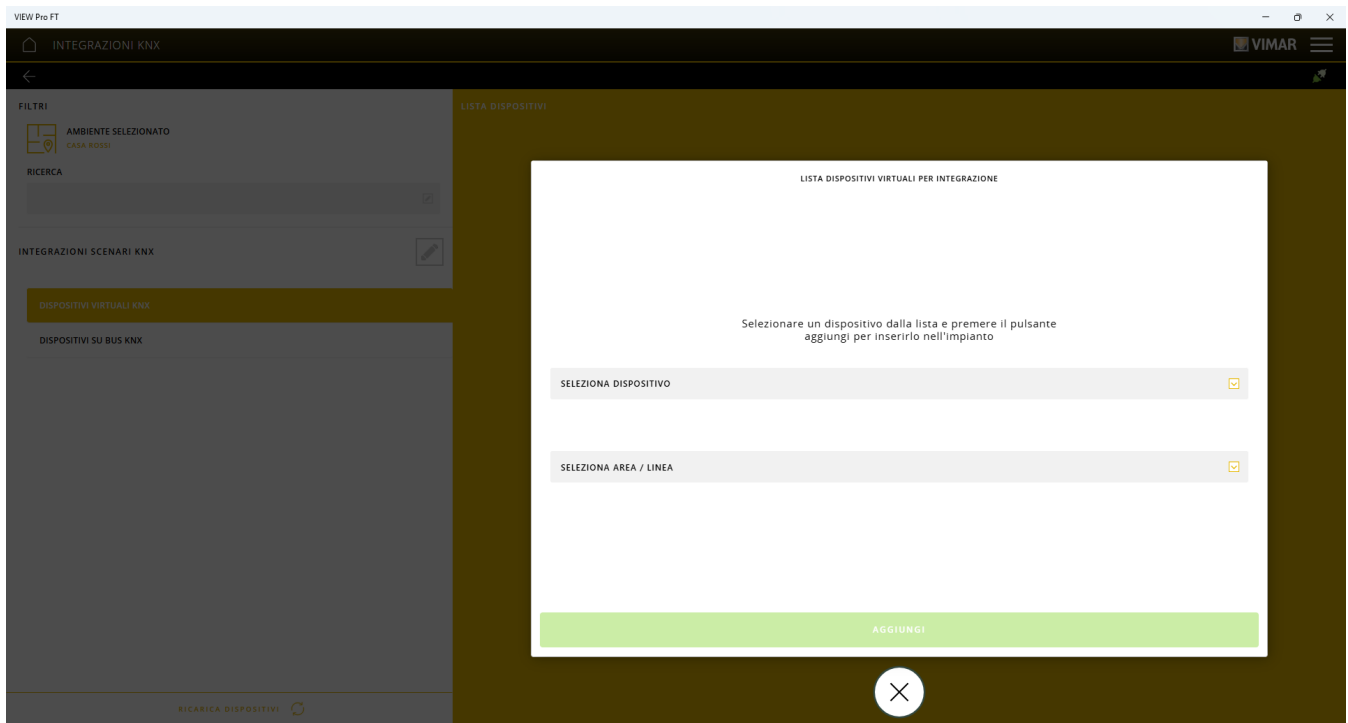

Use to select the virtual device from the list of those available (the App directly provides a list of devices that are compatible with the Vimar platform) and enter the number of the area and line to pair it with.

For example:

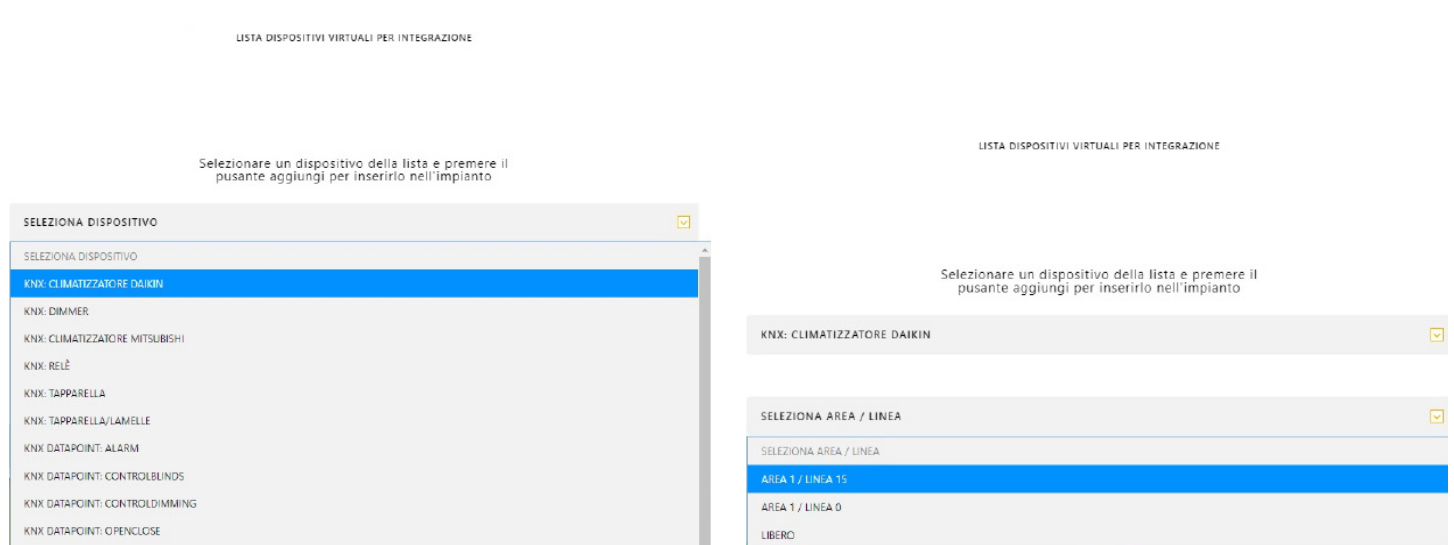

Then click on "ADD".

A screen is displayed to allow you to modify the environment where the device is enrolled if necessary (click on).

Configuration with View Pro App

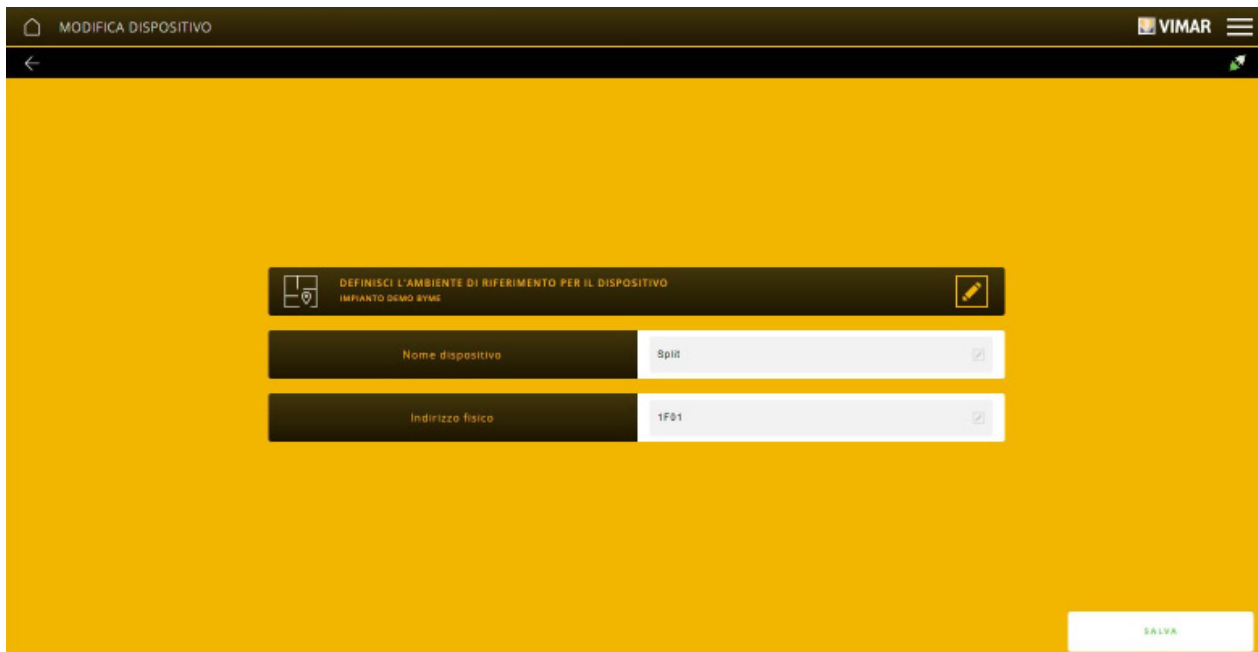

Click on "SAVE"; a screen displays the functional units that make up the enrolled device (which will subsequently need to be paired with the application that carries out the desired function).

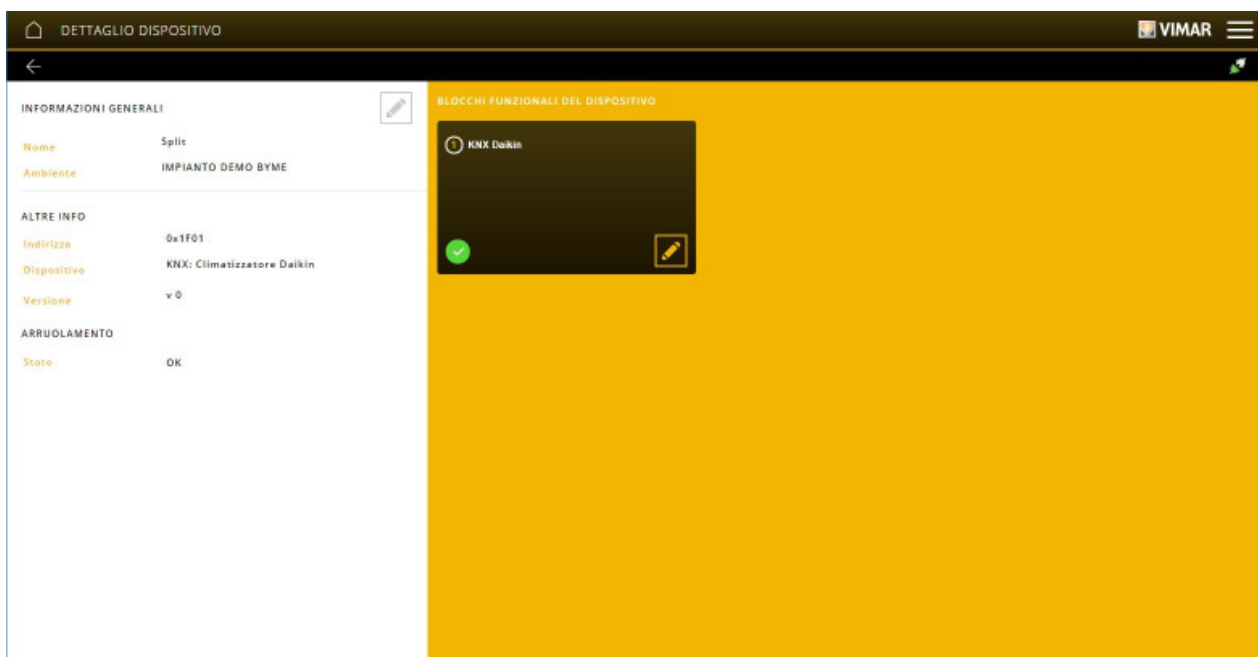

Configuration with View Pro App

The following list contains all the KNX devices (with their respective data points) which can be enrolled in the By-me Plus system.

SELEZIONA DISPOSITIVO
KNX: RELÈ
KNX: DIMMER
KNX: TAPPARELLA
KNX: TAPPARELLA/LAMELLE
KNX: CLIMA MITSUBISHI ME-AC-KNX-1-V2 (V. 0.8)
KNX: CLIMA MITSUBISHI INKNXMIT001000 (V. 1.X) / ME-AC-KNX-1-V2 (V. 1.X)
KNX: CLIMA DAIKIN INKNXDAI001000 (V. 0.4) / DK-AC-KNX-1 (V. 0.4)
KNX: CLIMA DAIKIN INKNXDAI001R000 (V. 1.X) / DK-RC-KNX-1 (V. 1.X)
KNX: CLIMA LG INKNXLGE001R000 (V. 1.X) / LG-RC-KNX-1I (V. 1.X)
KNX DATAPOINT: SWITCH (1.001)
KNX DATAPOINT: BOOL (1.002)
KNX DATAPOINT: ENABLE (1.003)
KNX DATAPOINT: RAMP (1.004)
KNX DATAPOINT: ALARM (1.005)
KNX DATAPOINT: BINARYVALUE (1.006)
KNX DATAPOINT: STEP (1.007)
KNX DATAPOINT: UPDOWN (1.008)
KNX DATAPOINT: OPENCLOSE (1.009)
KNX DATAPOINT: START (1.010)

KNX DATAPOINT: START (1.010)
KNX DATAPOINT: STATE (1.011)
KNX DATAPOINT: INVERT (1.012)
KNX DATAPOINT: DIMSENDSTYLE (1.013)
KNX DATAPOINT: INPUTSOURCE (1.014)
KNX DATAPOINT: RESET (1.015)
KNX DATAPOINT: HEAT/COOL (1.100)
KNX DATAPOINT: CONTROLDIMMING (3.007)
KNX DATAPOINT: CONTROLBLINDS (3.008)
KNX DATAPOINT: SCALING (5.001)
KNX DATAPOINT: VALUE1UCOUNT (5.010)
KNX DATAPOINT: VALUE1COUNT (6.010)
KNX DATAPOINT: VALUE2UCOUNT (7.001)
KNX DATAPOINT: TIMEPERIODMIN (7.006)
KNX DATAPOINT: VALUE2COUNT (8.001)
KNX DATAPOINT: VALUETEMP (9.001)
KNX DATAPOINT: VALUETEMPD (9.002)
KNX DATAPOINT: VALUETEMPA (9.003)
KNX DATAPOINT: VALUELUX (9.004)
KNX DATAPOINT: VALUEWSP (9.005)

KNX DATAPOINT: VALUETEMP (9.001)
KNX DATAPOINT: VALUETEMPD (9.002)
KNX DATAPOINT: VALUETEMPA (9.003)
KNX DATAPOINT: VALUELUX (9.004)
KNX DATAPOINT: VALUEWSP (9.005)
KNX DATAPOINT: VALUEPRES (9.006)
KNX DATAPOINT: VALUEHUMIDITY (9.007)
KNX DATAPOINT: VALUEAIRQUALITY (9.008)
KNX DATAPOINT: VALUETIME1 (9.010)
KNX DATAPOINT: VALUETIME2 (9.011)
KNX DATAPOINT: VALUEVOLT (9.020)
KNX DATAPOINT: VALUECURR (9.021)
KNX DATAPOINT: POWER (9.024)
KNX DATAPOINT: VALUEVOLUMEFLOW (9.025)
KNX DATAPOINT: VALUE4UCOUNT (12.001)
KNX DATAPOINT: VALUE4COUNT (13.001)
KNX DATAPOINT: VALUEPOWER (14.056)
KNX DATAPOINT: SCENECONTROL (18.001)
KNX DATAPOINT: HVACMODE (20.102)
KNX DATAPOINT: CHANGEVERMODE (20.107)

Configuration with View Pro App

Third-party gateways which can be enrolled in the By-me Plus system and their functions.

	Mitsubishi via ME-AC-KNX- 1-V2 with databank version 0.8	Mitsubishi via ME-AC-KNX-1-V2/ INKNXMIT001I000 with databank version 1.x	Daikin via DK-AC-KNX-1/ INKNXDAI001I000 with databank version 0.4	Daikin via DK-RC-KNX-1/ INKNXDAI001R000 with databank version 1.5	LG via LG-RC-KNX-1i/ INKNXLGE001R000 with databank version 1.x
Split on control.			✓		
Split control and on status.	✓	✓		✓	✓
Setpoint up/down control.	✓	✓	✓	✓	✓
Operating mode setting control.	✓	✓	✓	✓	✓
Fan speed up/down control.	✓	✓	✓	✓	✓
Automatic fan speed enable control.					✓
Slat position up/down control.	✓	✓		✓	
Vertical (tilt) swing enable status and control.			✓		
Horizontal (tilt) swing enable status and control.			✓		
Slat up-down (tilt) swing function enable status and control.					✓
Slat up-down (rotation) swirl function enable status and control.					✓
Slat left-right (tilt) swing function enable status and control.					✓
Slat left-right (rotation) swirl function enable status and control.					✓

Configuration with View Pro App

4.2.2.1 Compatibility with Mitsubishi devices

The By-me Plus system allows integration with Mitsubishi devices provided only the Intesys ME-AC-KNX-1-V2 gateway, which is compatible with version 0.8 of the ETS data-bank, is used.

From the APPLICATIONS menu, select MITSUBISHI AIR CONDITION to choose whether to use the device with all the operating modes of the split or without the FAN mode.

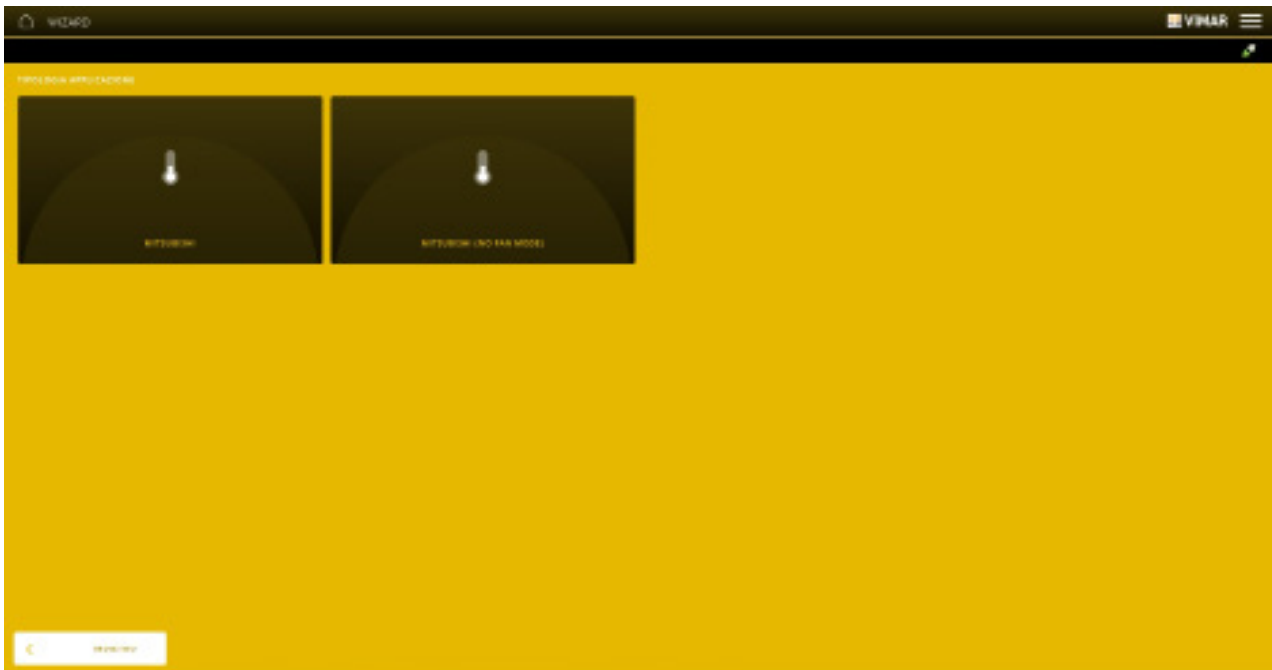

Once the device has been added, the parameters can be displayed by clicking on  of the related functional unit.

For instance, by selecting MITSUBISHI, the parameters are those shown on the screen below.

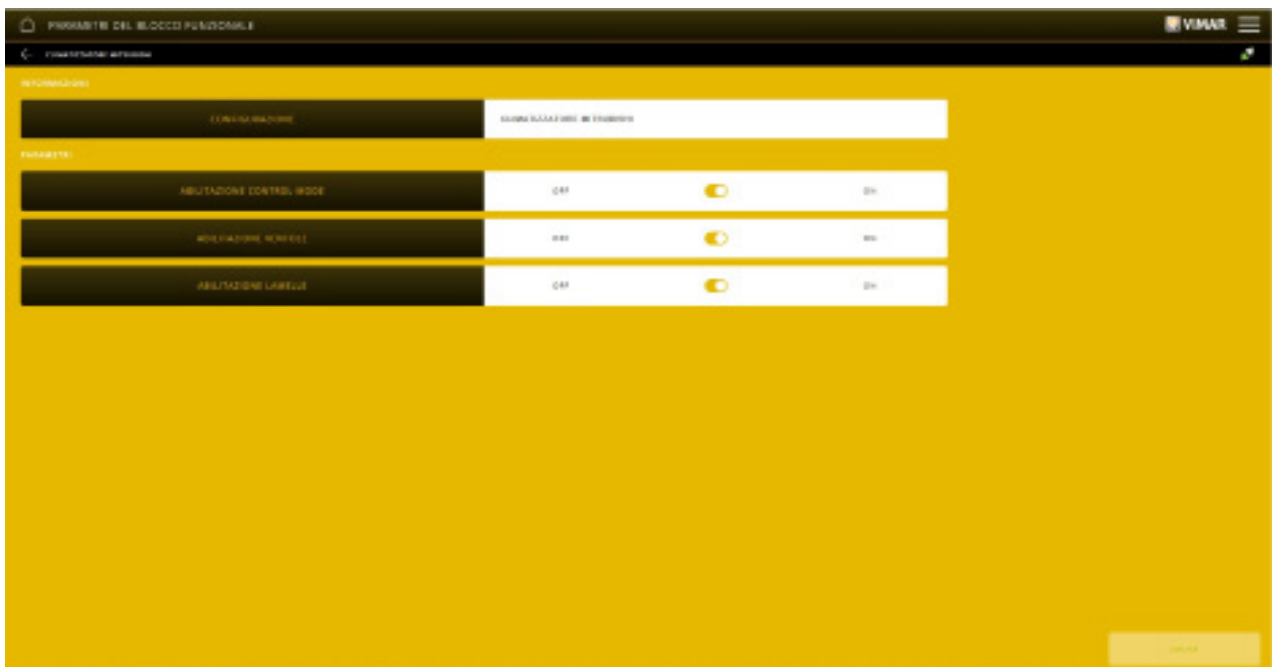

As you can see, you can choose whether to enable the possibility of setting and displaying the operating mode, the speed of the fans or the position of the slats on the View App and on the supervisors.

Configuration with View Pro App

4.2.2.2 DEVICES ON KNX BUS

Designed for the enrolment of KNX devices directly on the bus (such as the weather station 01546).

N.B. For KNX devices, enrolment can only be performed via bus and not via catalogue.

4.2.2.2.1 Enrolment of the weather station 01546.

Select "DEVICES ON KNX BUS" then  to enrol the weather station in the selected environment.

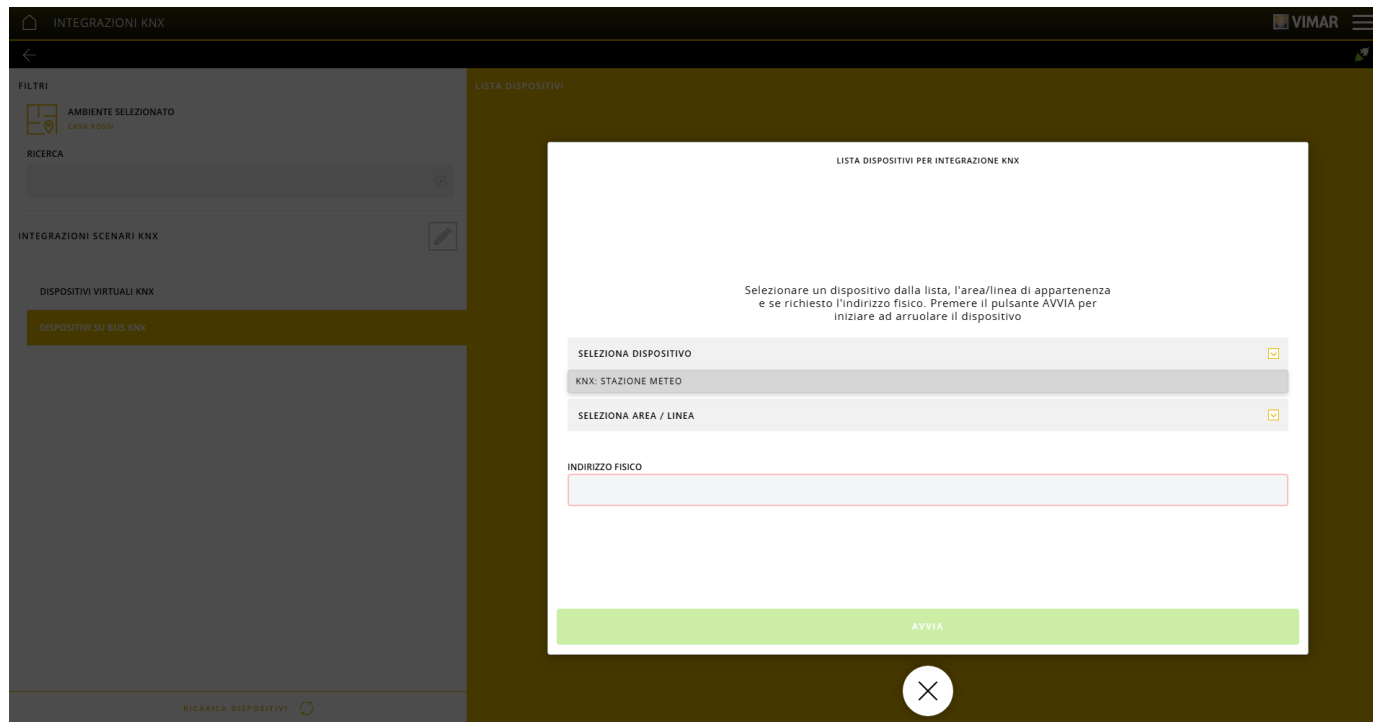

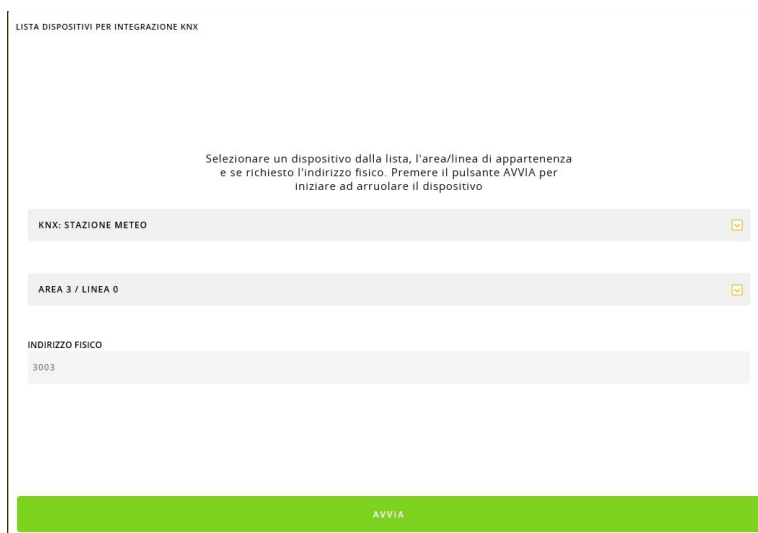

Select the weather station, insert the Area and Line and, where necessary, manually enter the physical address.

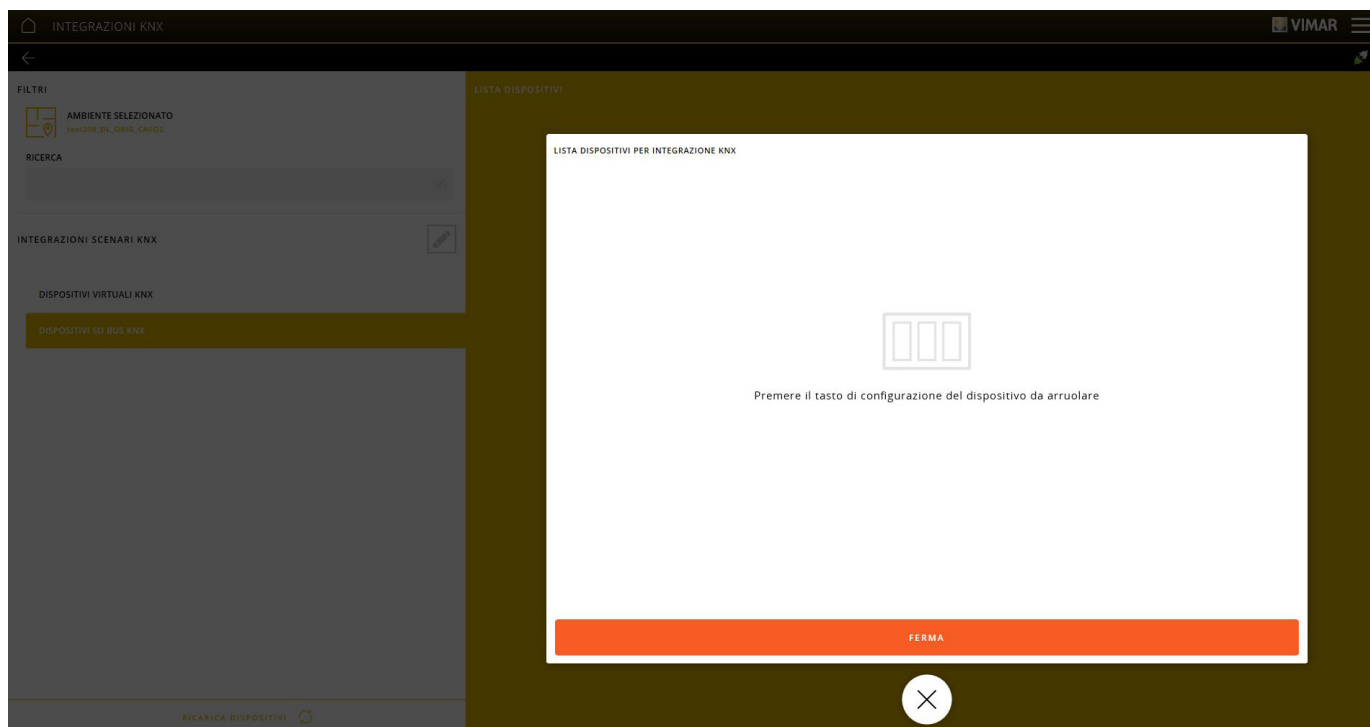

Confirm with "START" and then press the weather station configuration push button.

Configuration with View Pro App



At the end of the enrolment process, the screen displayed allows you to name the device and assign it to the environment (click on ).

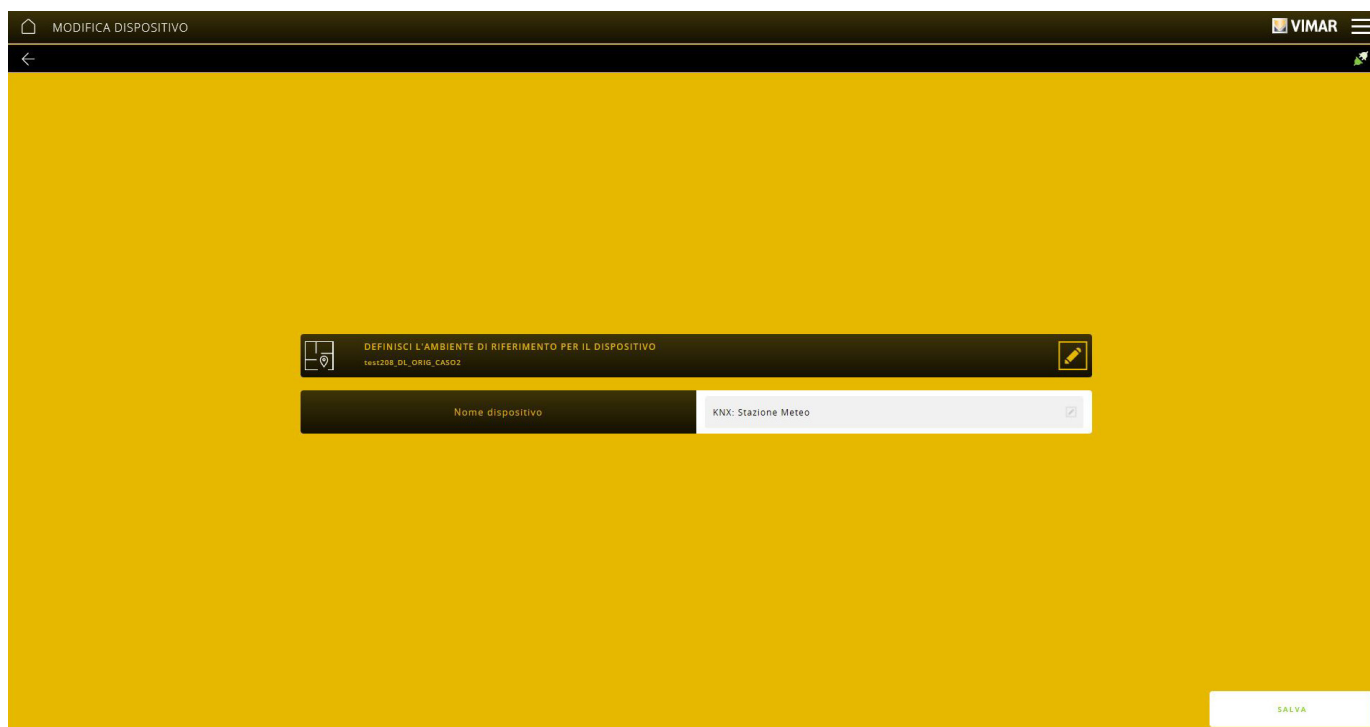

The procedure described above should be carried out for each weather station that needs to be enrolled.

Configuration with View Pro App

Once enrolment is complete, for the "DEVICES ON KNX BUS" menu, all the weather stations that can subsequently be used in the "SENSORS" applications will be displayed.

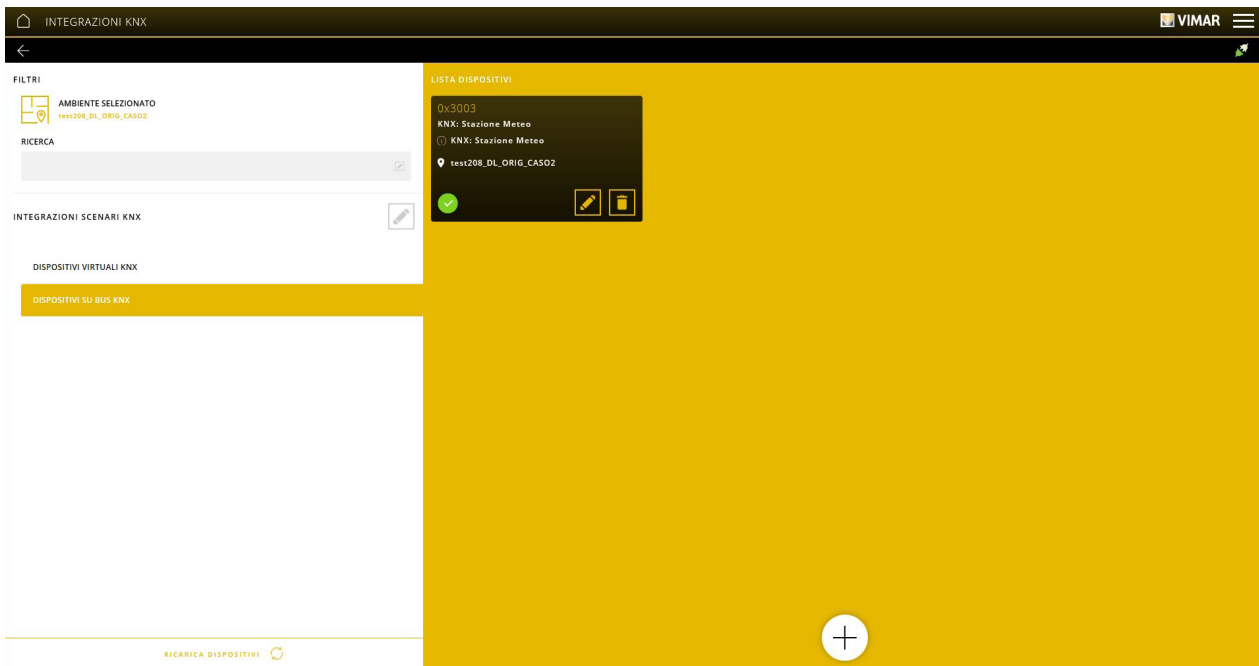

For the configuration of weather station 01546 see para. 4.6.

For the description of the BY-ALARM INTEGRATION DEVICES and VIDEO DOOR ENTRY SYSTEM INTEGRATION DEVICES menus, see para. 4.5.

Configuration with View Pro App

4.2.2.3 INTEGRATION OF KNX SCENARIOS

Allows the configuration of the integration function between the scenarios defined in the By-me Plus system via the KNX bus.

To access the configuration, select  in the INTEGRATION OF KNX SCENARIOS section.

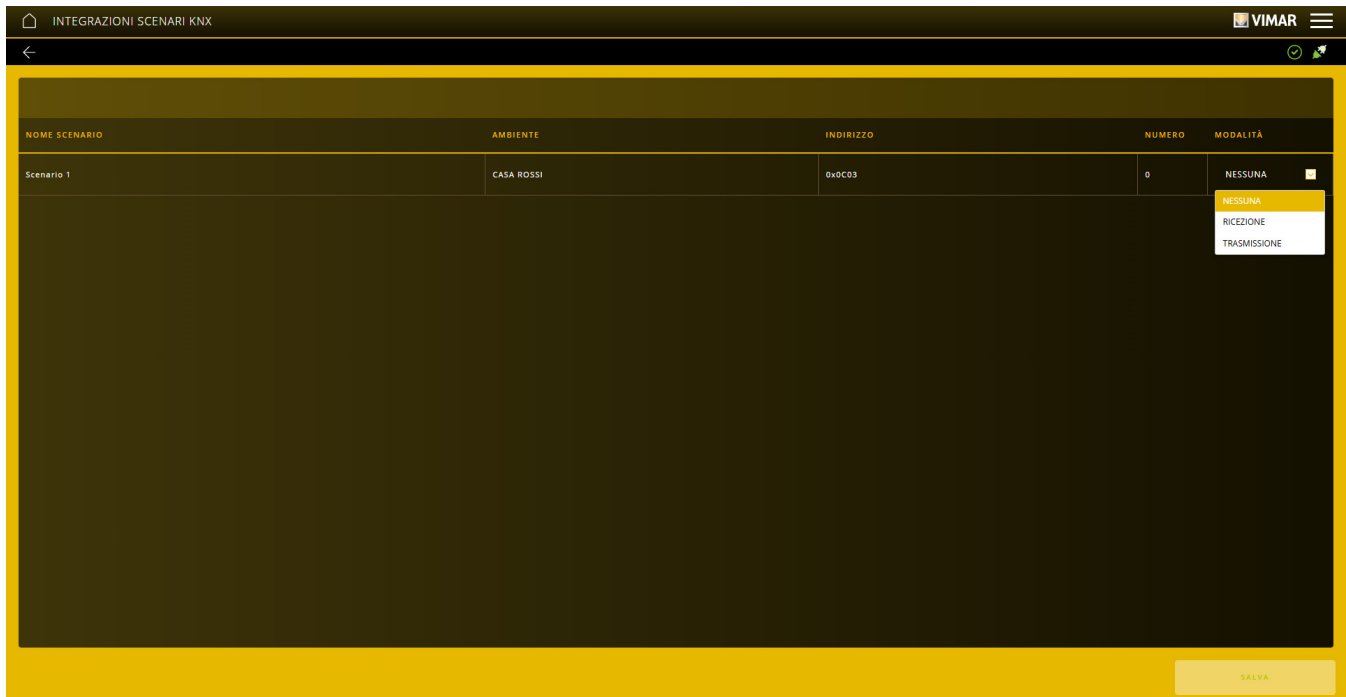

The screen shows all the scenarios defined in the By-me Plus system, with the following information:

- Name and environment associated with the scenario
- Group address and number associated with the scenario for the purpose of integration with KNX systems
- Method of integration required, which defines the type of integration which can be carried out with the scenario:
 - None -> No integration mechanism is present for the current scenario
 - Reception -> If the home automation system gateway detects a KNX type 18.001 datagram related to the group address and number associated with the current scenario, it will trigger the scenario activation. This mode is useful for recalling a By-me Plus scenario from external systems
 - Transmission -> For every scenario activation within the By-me Plus system, the home automation system gateway will send a KNX type 18.001 datagram using the group address and number associated with the scenario called up. This integration mode is useful for propagating scenario activation also to external systems

Configuration with View Pro App

4.2.3 RF ENOCEAN INTEGRATION

This menu allows you to interact in the By-me Plus system the controls with 4 push buttons art. 03955 and the multifunction actuators 01796.2.

To proceed, you first need to have enrolled VIA BUS one or more EnOcean interfaces art. 20508-19508-14508 following the procedure illustrated in para graph 4.2.1.1. If the EnOcean interface has been enrolled VIA CATALOGUE then you will be unable to proceed.

Select RF ENOCEAN INTEGRATION to display the screen with the EnOcean interface(s) enrolled; then select the desired one.

Select  to enrol the EnOcean device in the interface you previously selected; you will be asked to select the type of device (control or actuator) to associate.

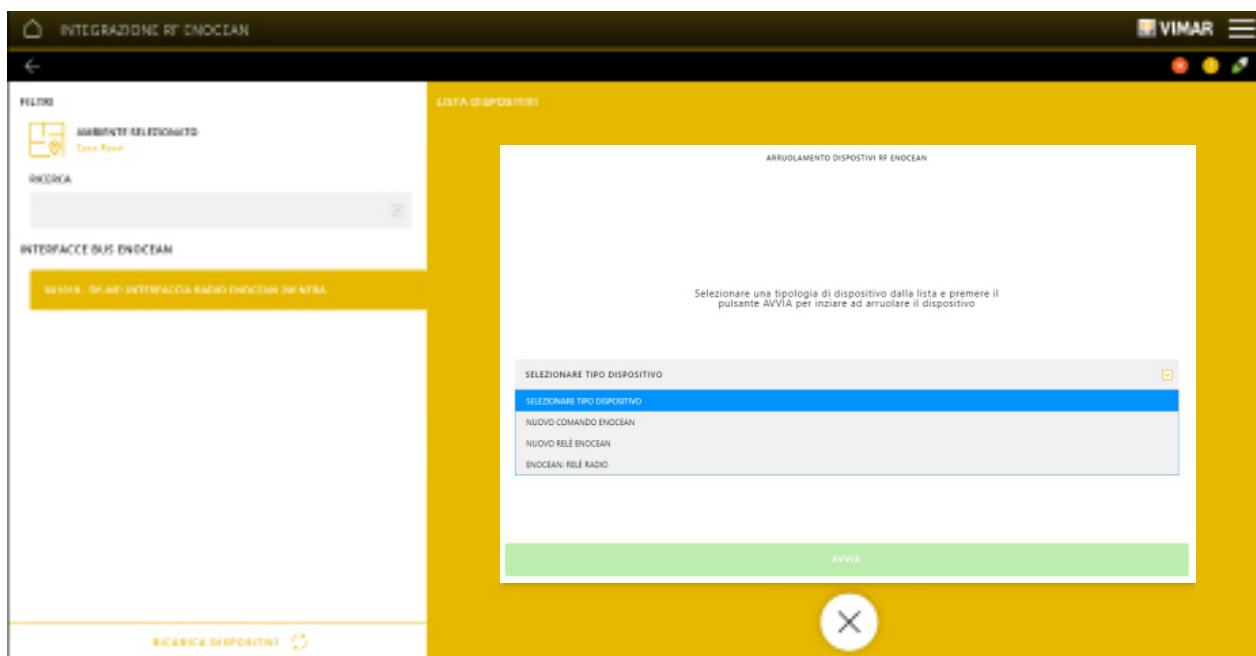

- In the case of a control with 4 push buttons (NEW ENOCEAN CONTROL) press the desired button.

- In the case of an actuator (NEW ENOCEAN RELAY) you will first need to associate the device (see instruction sheets for art. 01796.2 and 01796.1) and then press the configuration push button on the EnOcean interface.

Confirm with "START".

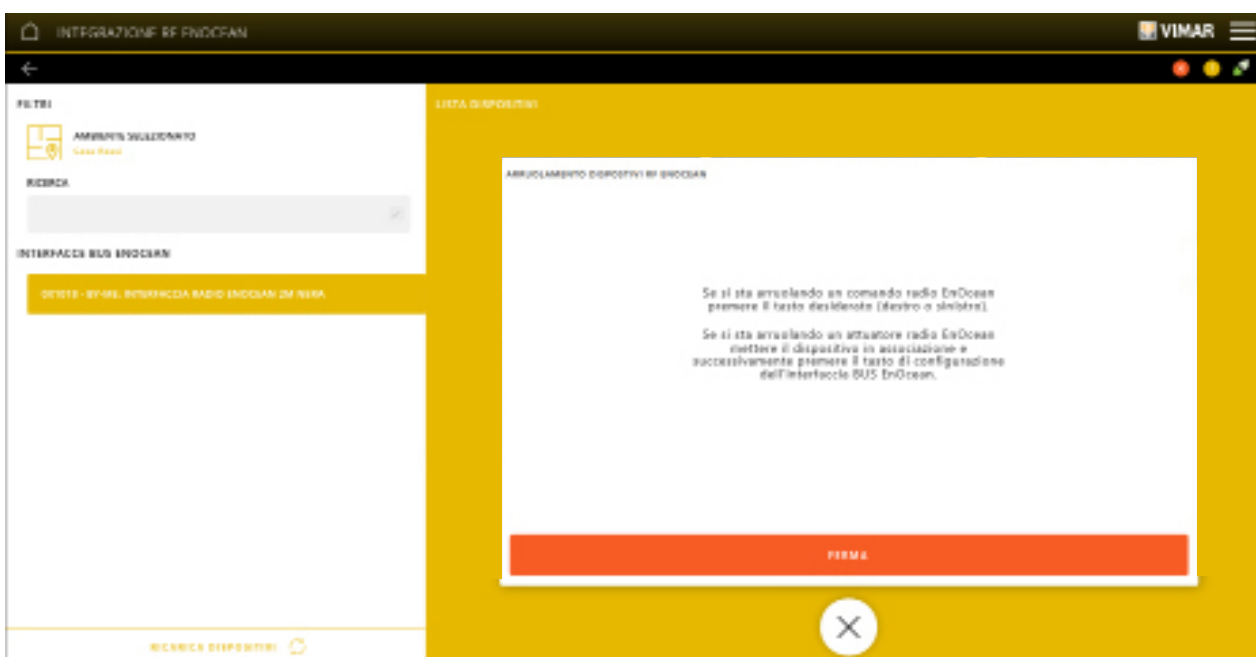

At the end of the enrolment process, the screen displayed allows you to name the device and assign it to the environment (click on ).

Configuration with View Pro App

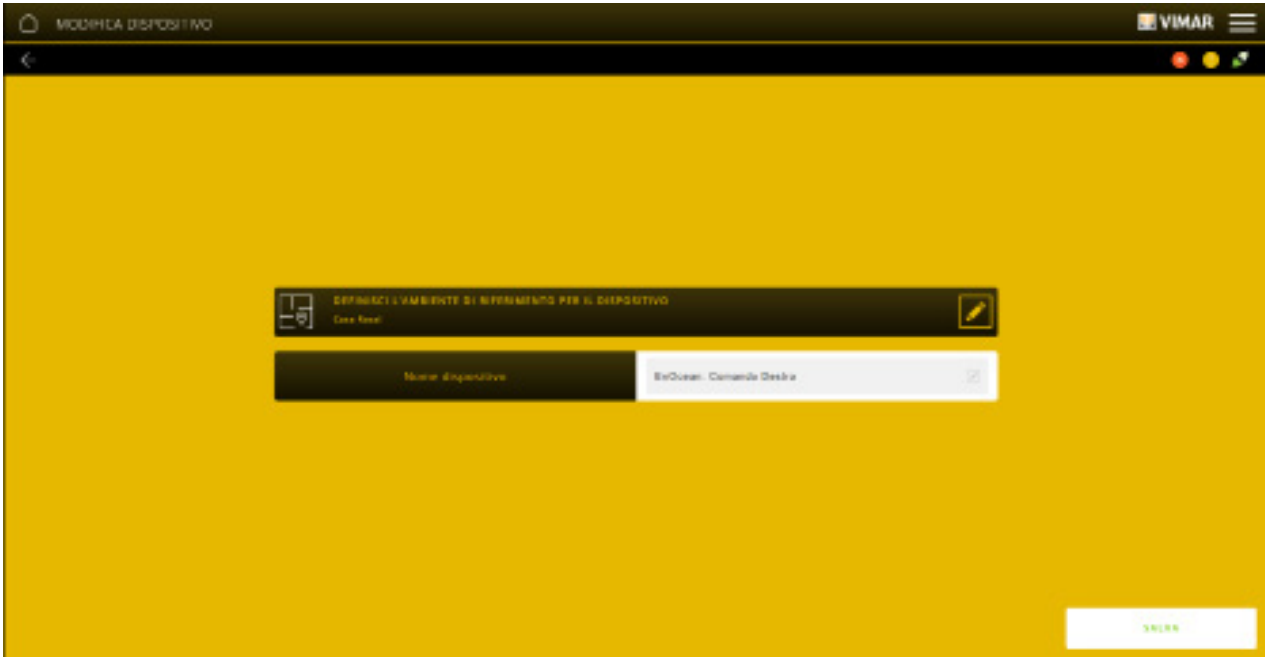

The procedure described above should be carried out for each device that needs to be enrolled.

Once enrolment is complete, for the EnOcean interface selected, all the related functional units that can subsequently be used in the various applications will be displayed.

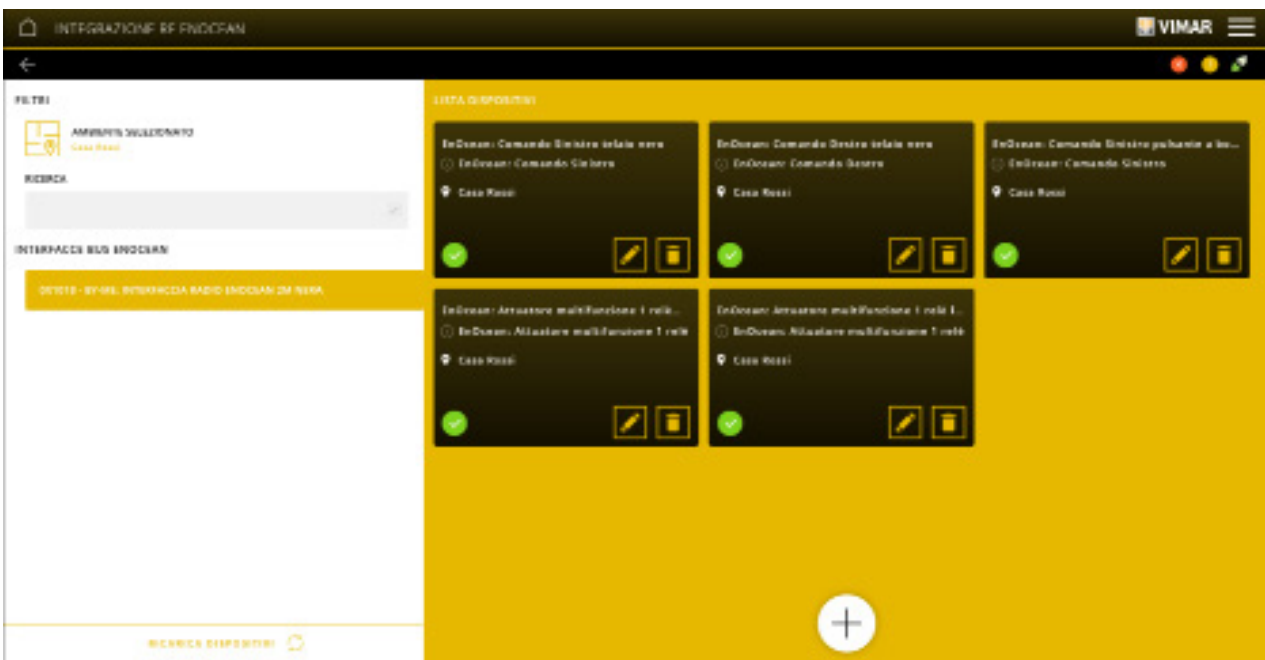

Configuration with View Pro App

4.2.3.1 Pairing of one or more EnOcean actuators with an already enrolled EnOcean actuator.

This option allows you, within the same application, to control several loads (associated with the respective actuators) using a single button; for instance, you can turn on several lights in different areas of the home from a single lighting device, avoiding having to configure a dedicated scenario.

Thanks to this function, there are no restrictions relating to the number of actuators that can be paired.

From the screen relating to the EnOcean interfaces, select the desired one and click on :

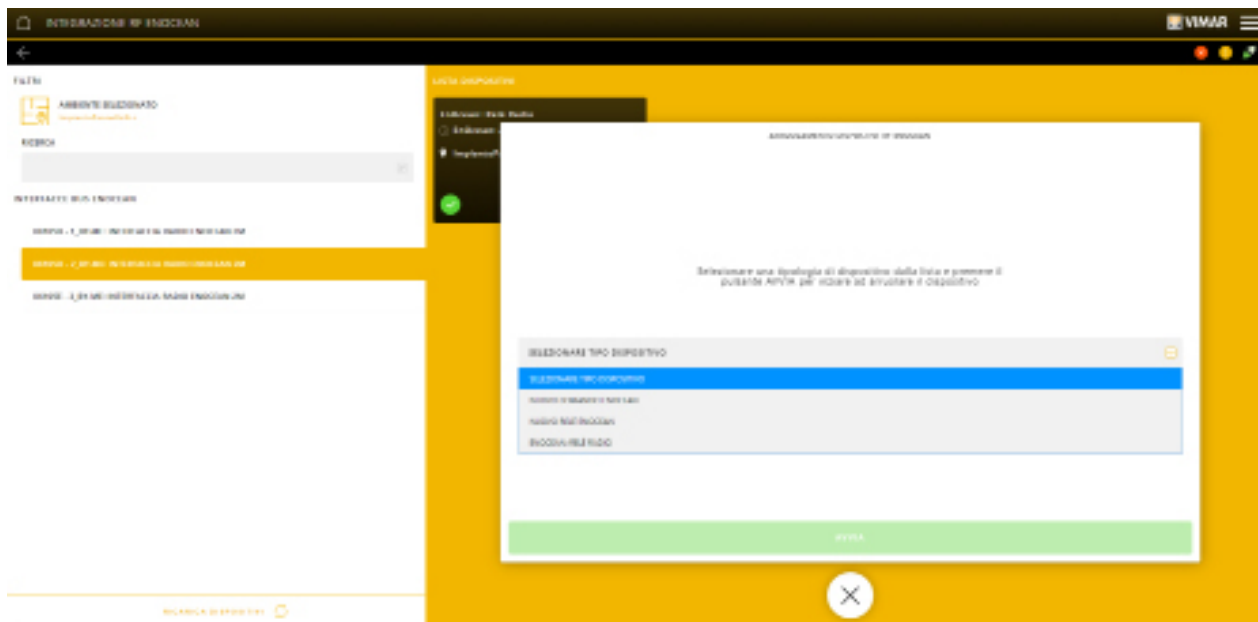

Select the actuator already enrolled (ENOCOAN: RADIO RELAY) and click on "START".

Lastly, the App displays a confirmation message for the pairing performed.

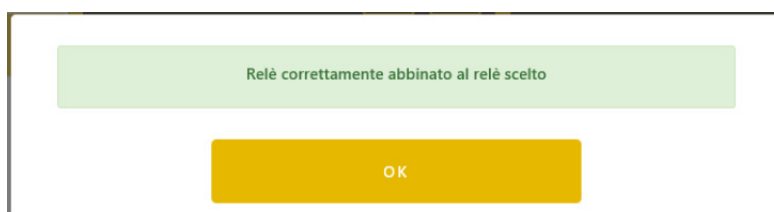

Configuration with View Pro App

4.2.4 DALI-2 INTEGRATION

This menu allows you to integrate DALI and DALI-2 devices in the By-me Plus system via actuators 01419.1.

To proceed, you first need to have enrolled VIA BUS one or more actuators art. 01419.1 following the procedure illustrated in para. 4.2.1.1.

If the actuator has been enrolled VIA CATALOGUE then you will be unable to proceed.

Select DALI-2 INTEGRATION to display the screen with the actuator or actuators 01419.1 enrolled.

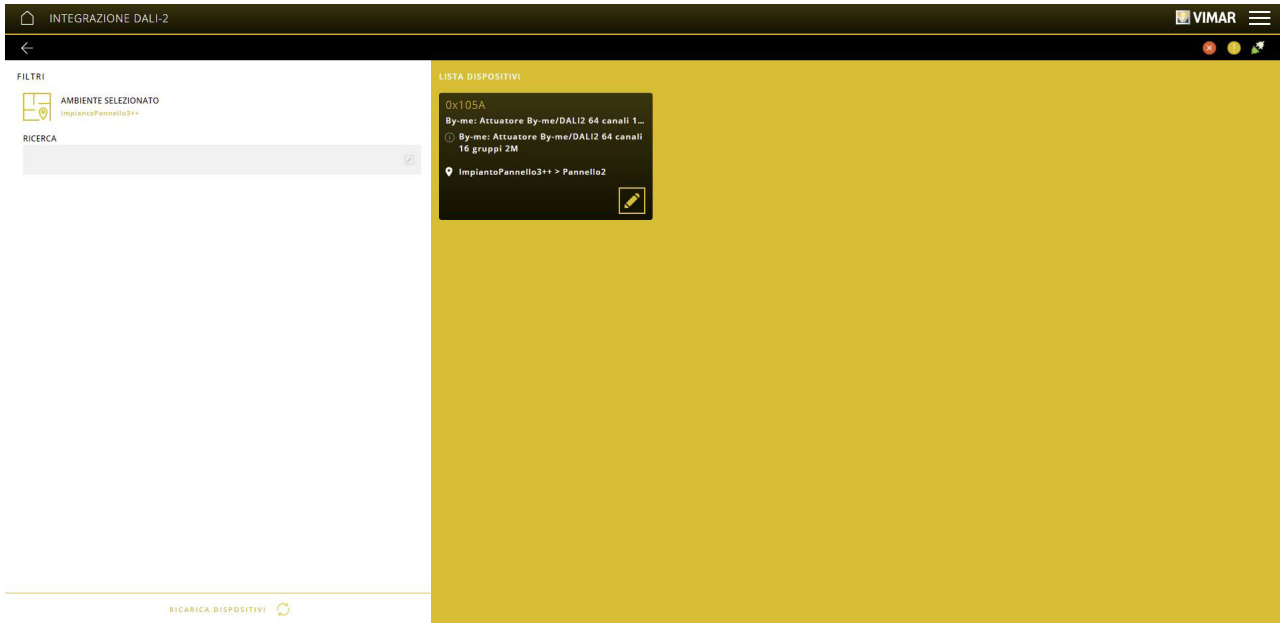

Select the desired actuator; the detailed screen will be as follows:

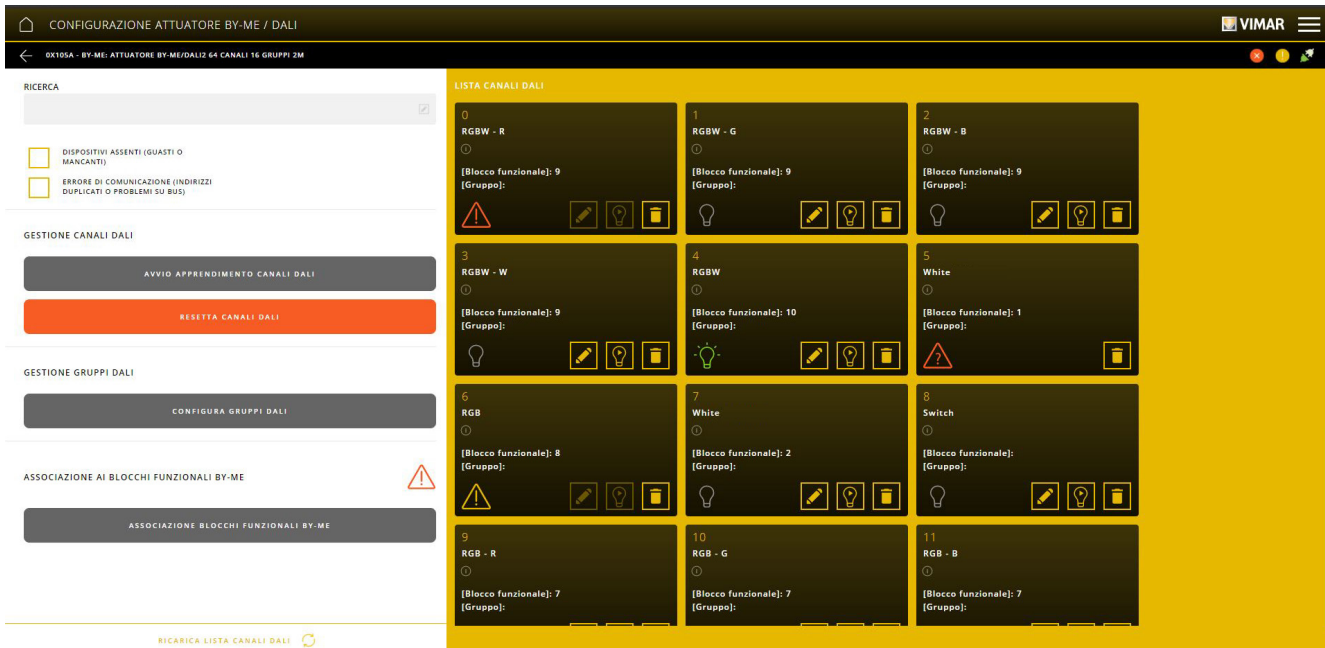

The actuator consists of 16 independent functional units to which up to 64 DALI/DALI-2 channels can be paired.

Configuration with View Pro App

Each DALI channel is represented as follows:

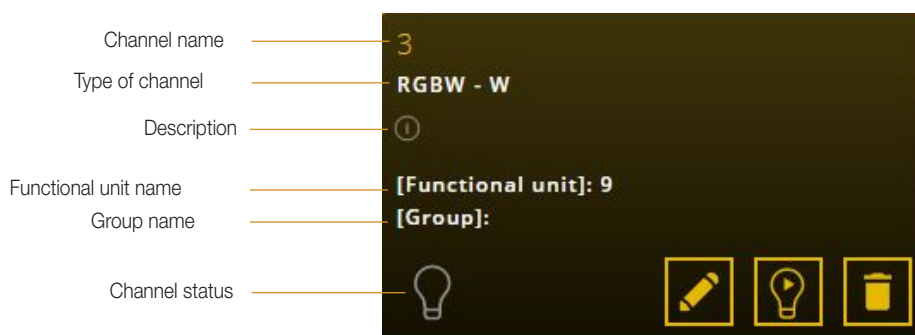

Click on  to assign the channel a name and set all the respective parameters.

Click on  to perform the channel test, i.e. the lamp paired with it will start to flash.

Click on  to delete the channel from the configuration; this channel is also reset on the DALI bus.

Channel state.

To update the state of the channels click on "RELOAD LIST OF CHANNELS"  :

-  channel on and working properly.

-  channel off and working properly.

For the configuration of actuator 01419.1 see para. 4.7.

Configuration with View Pro App

4.3 Applications

Applications are designed to define, for each environment, the function to be carried out (in other words what is to be controlled) and the parameters tied to operation; to do this, within each application, the functional units of the devices previously enrolled will need to be paired. This is therefore the phase during which the functions to be carried out are assigned (with properly set parameters), the loads to be controlled, the utilities to be managed, etc. in relation to the environments created. You can also define applications which entirely or partly consist of devices enrolled VIA CATALOGUE, performing the same configuration and parameter setting operations performed on the devices enrolled VIA BUS; these applications will however not be operational until the physical enrolment of the devices has been completed.

From the main menu, click on APPLICATIONS; the applications available are the characteristic By-me Plus system applications in other words ACCESSES AND PRESENCES (for the management of doors, gates, etc.), BLINDS AND ROLLER SHUTTERS, LIGHTS, MUSIC AND AUDIO (sound system), temperature control (CLIMATE CONTROL), SENSORS (for the management of humidity, temperature, rain sensors, etc.), load control and energy management (ENERGY), SPRINKLER SYSTEM, OTHER (control activation via timed programmes) and SCENARIOS.

Click on to select the environment with which to pair the application and then select the desired one (for instance LIGHTS).

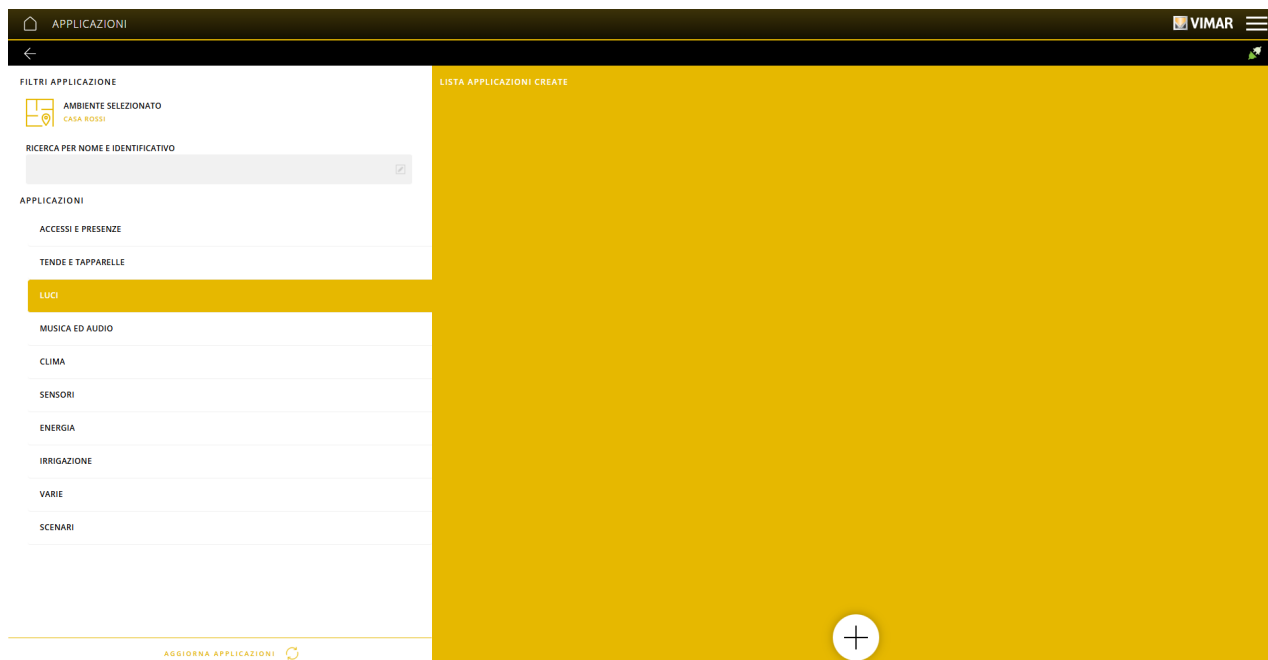

Click on .

The screen displayed allows you to define whether the function to be carried out is the switching on and off of lights (ON-OFF or TIMED ON-OFF), dimming (DIMMING OF WHITE, COLOURED or DYNAMIC WHITE LIGHTS, TIMED DIMMER ON-OFF or TIMED DYNAMIC WHITE), control (AUTOMATIC BRIGHTNESS CONTROL), etc. The PHILIPS HUE option allows the management of Philips lamps with Friends of Hue standard whereas DALI2 allows the management of DALI devices via actuator 01419.1. CUSTOMISED WIDGET creates an application with virtual datapoints to interact with a KNX system; this application generates a dedicated screen on the touch screens for the management of the virtual datapoints in order to control the KNX system.

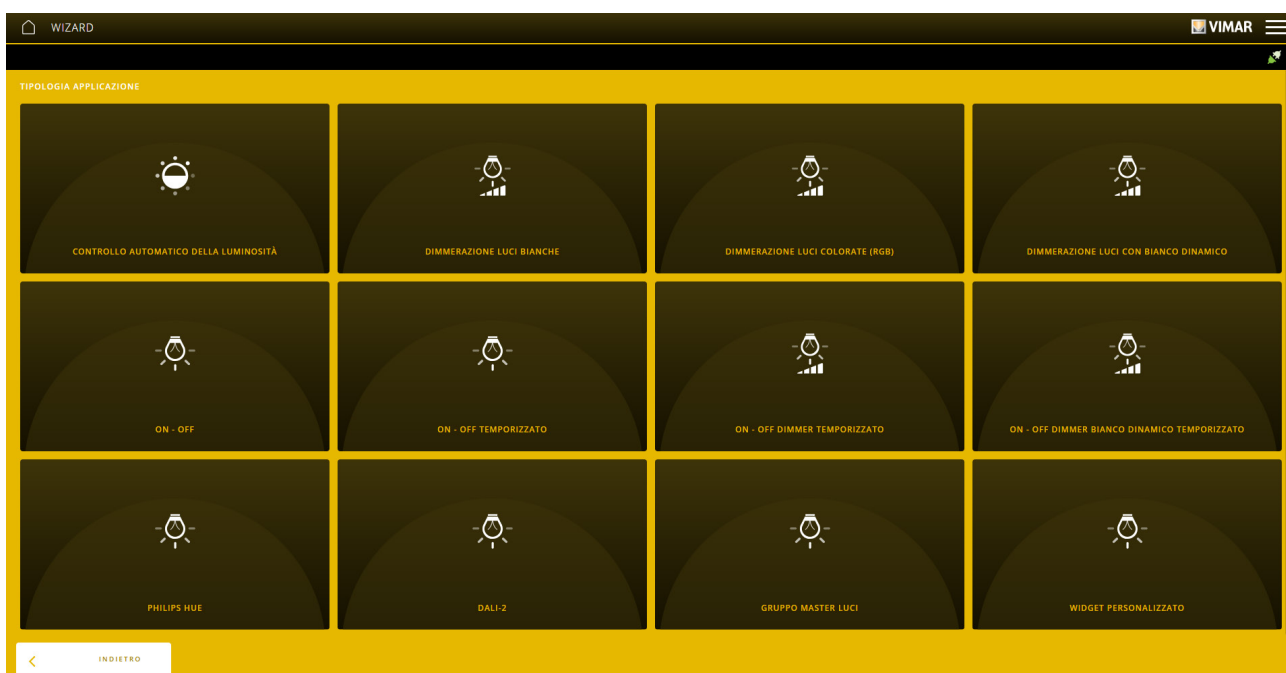



Configuration with View Pro App

Select the desired function; you will be prompted to enter the name that identifies it within the environment. **We recommend you assign an unequivocal name that is easy to identify among all the devices in the system (useful to speed up diagnostics tasks, maintenance, etc.).**

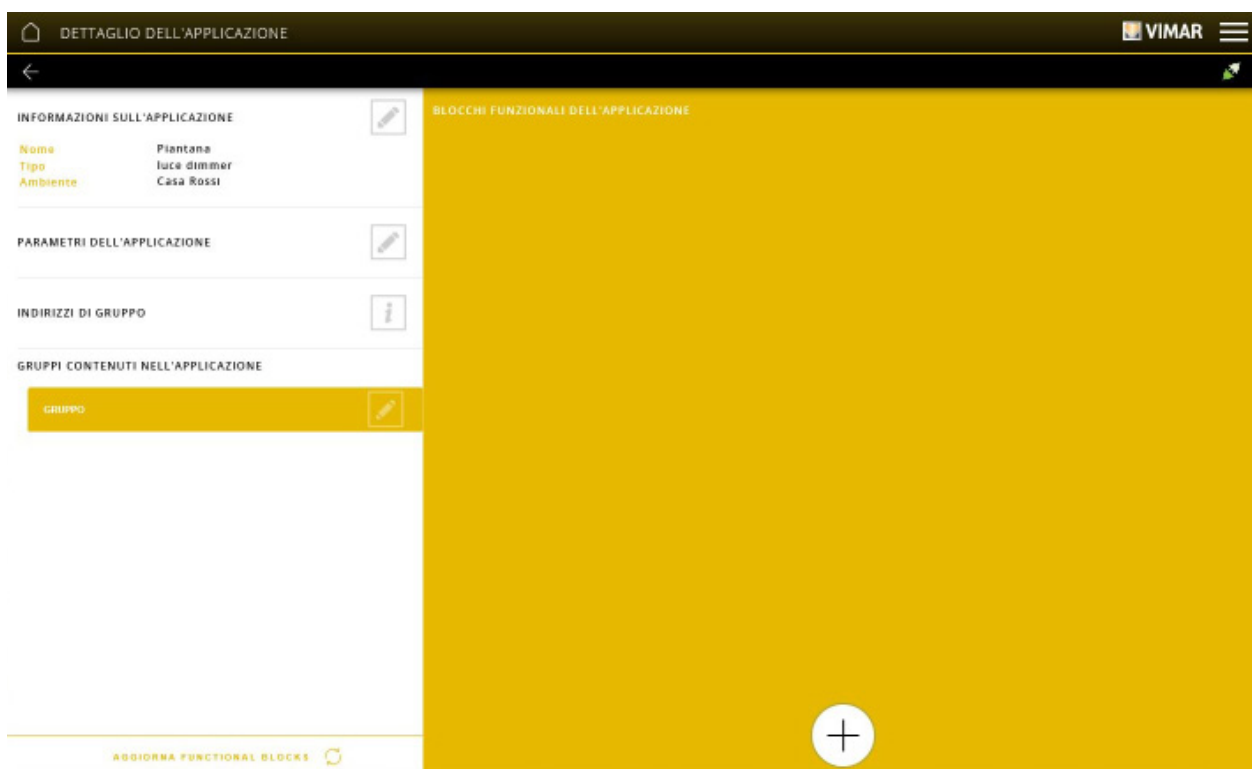
Click on "END"; the screen displayed is where the functional units of the devices are paired with the application.



Click on ; the screen displayed shows the environment and the devices paired with it.

Click on the device (a drop-down menu opens); pair the desired functional unit with the application by clicking on the its name (the pairing will be highlighted by ).

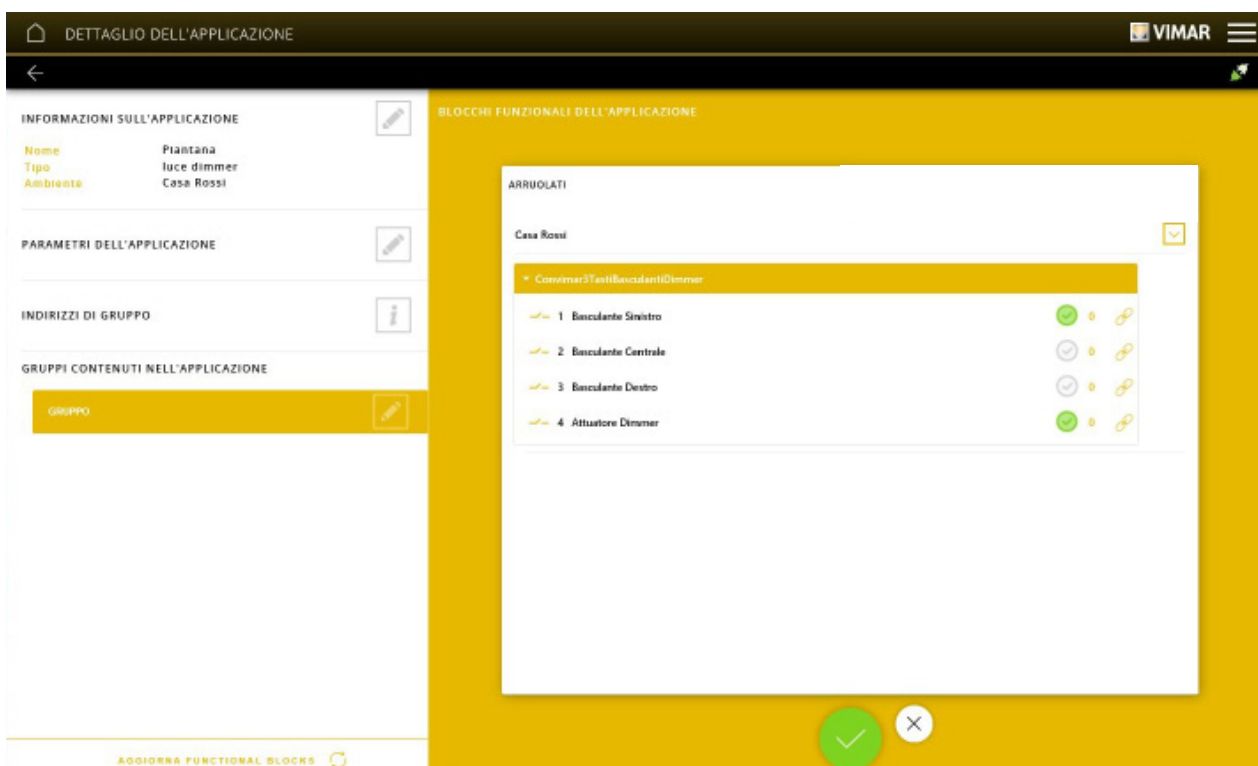

Click on  to confirm (use  to cancel the operation).

Configuration with View Pro App

Once all the functional units of the devices have been paired, the App will display the pairings made.

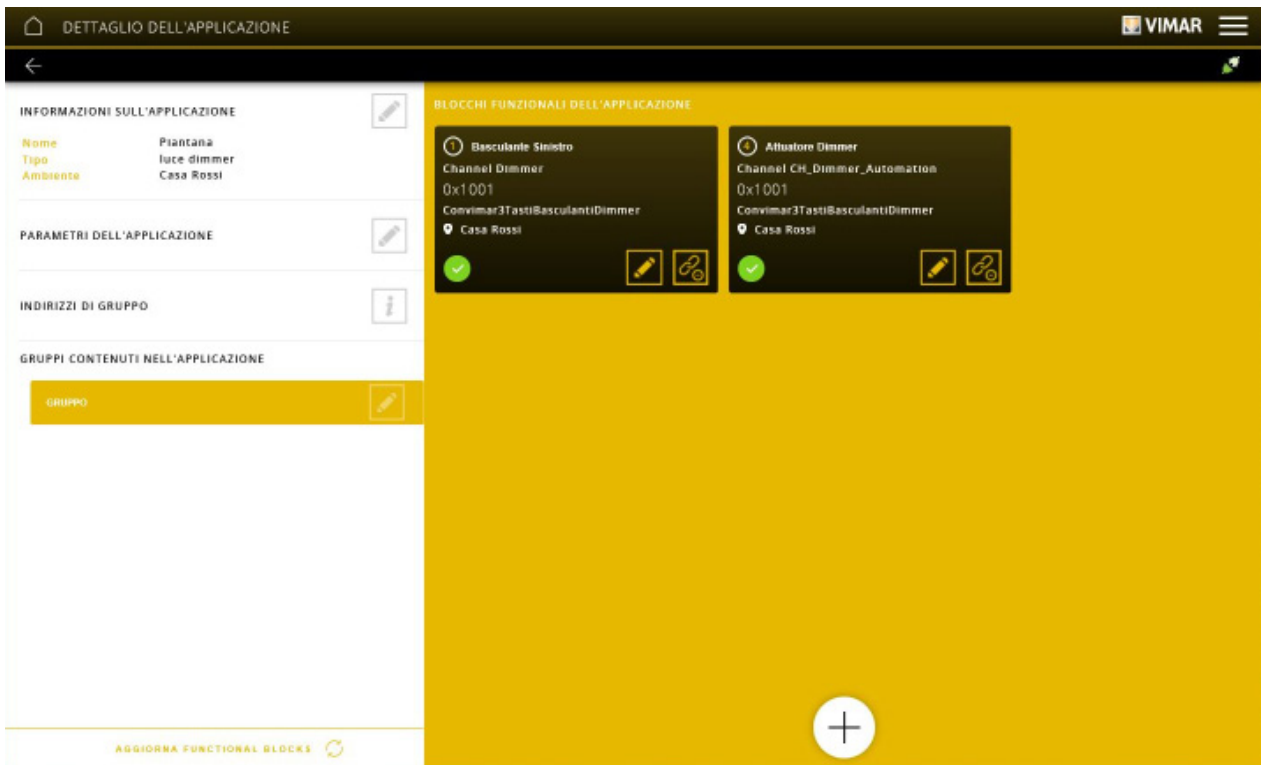

Click on  to display the paired parameters, set them and confirm with "SAVE" .

The following example screen shows the parameters that can be set for the left rocker button of the 3-module control device.

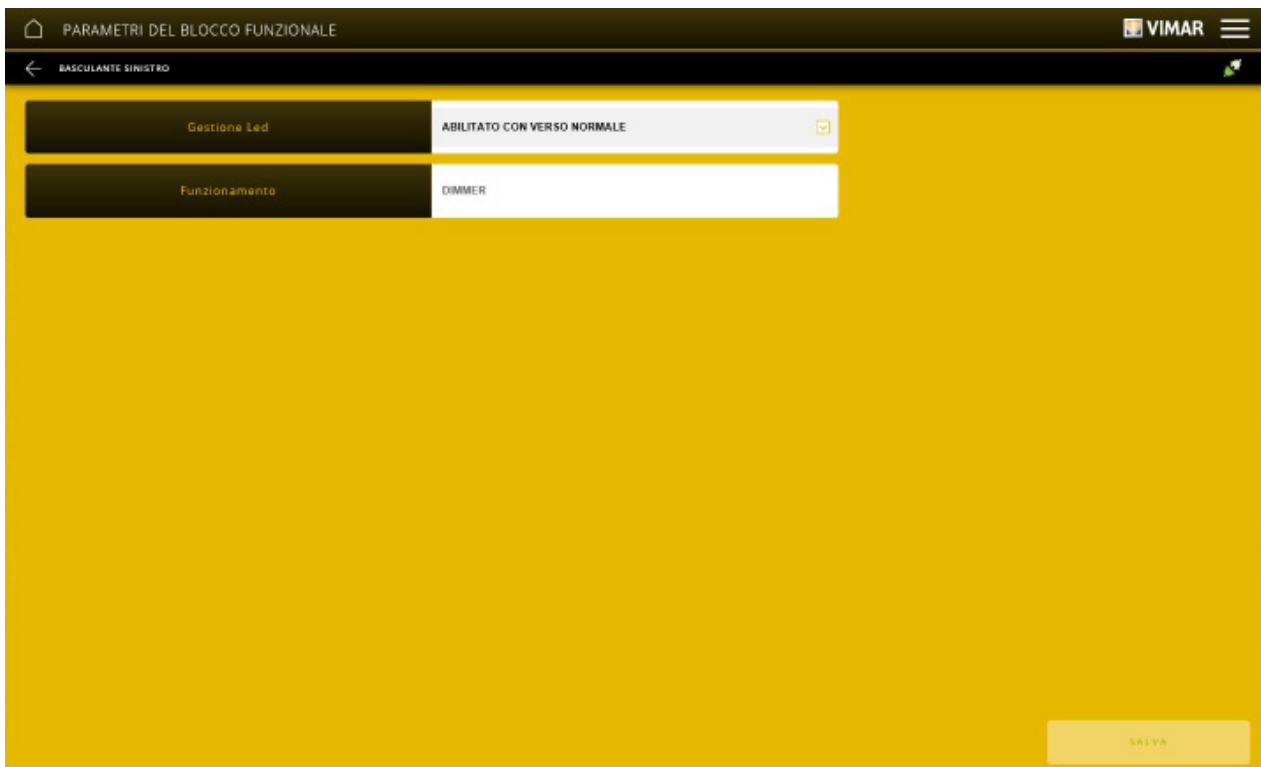

The  button is designed to remove the functional unit from the group.

The  button is designed to display the group addresses of the application.

For addresses not associated with By-me Plus devices, you can also customise the value of the address itself.

Configuration with View Pro App

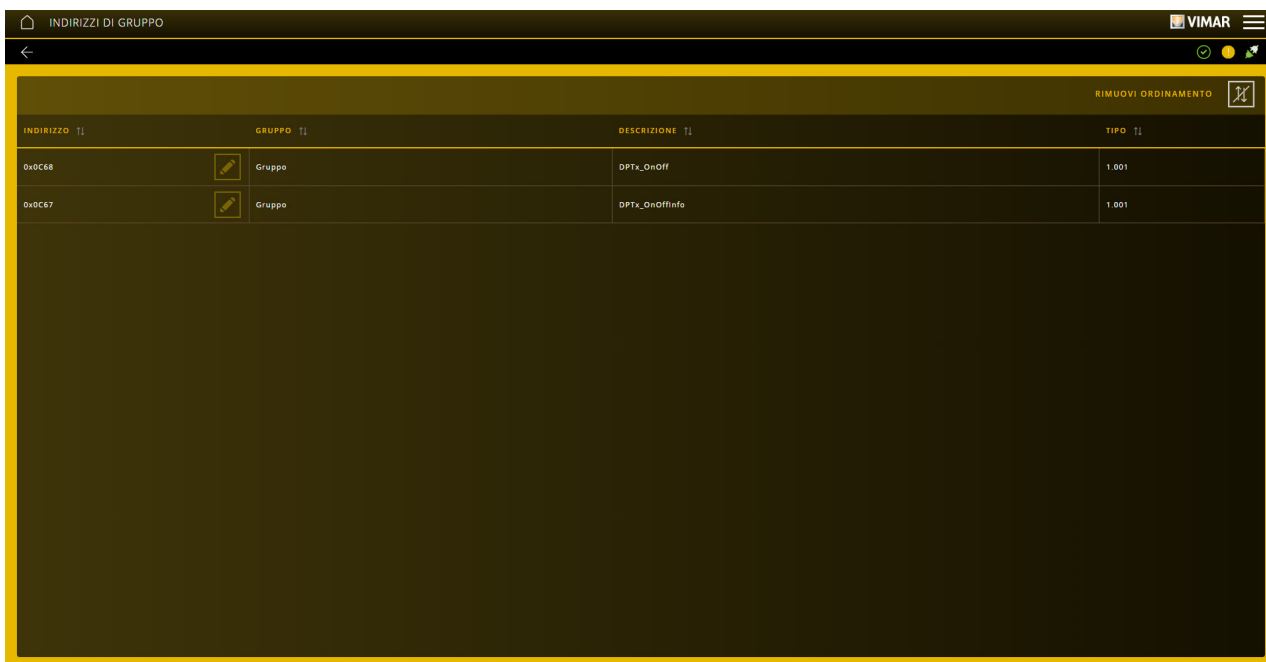

Once all the applications have been created for the various types of functions, the APPLICATIONS menu will be displayed, as in the following example:

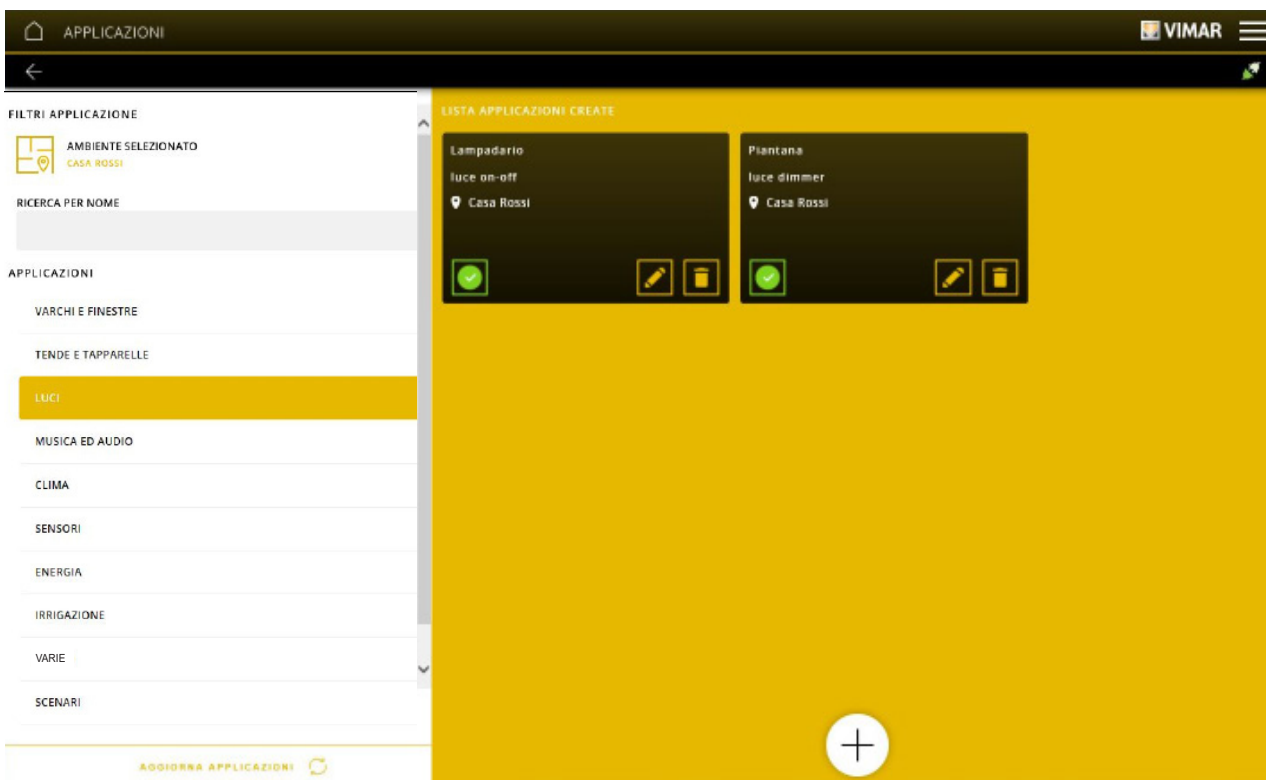



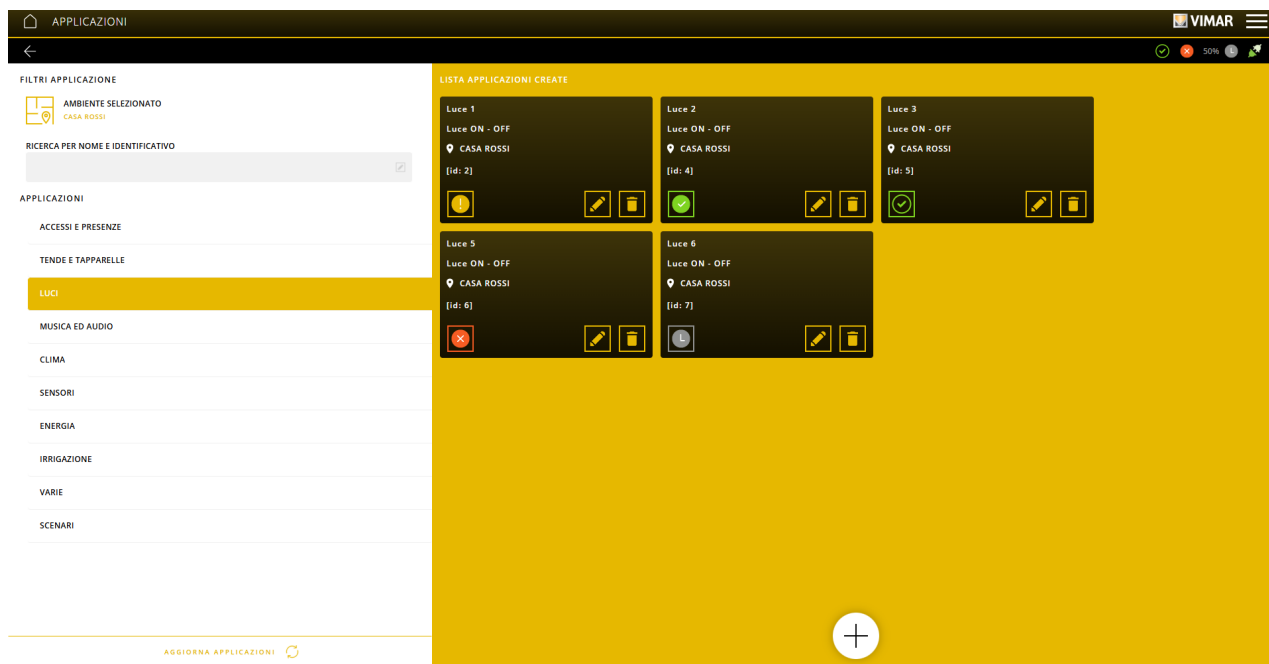

Configuration with View Pro App

All the applications defined are visible in the APPLICATIONS page, divided up by reference category; each application is represented as in the example below:



Every application is identified by a box containing the following information:

- The name associated with the application
- The name of the type of application
- The environment in which the application was defined
- The status icon of the application, obtained as a combination of the statuses of the functional units (and related devices) it contains, which may take the forms shown in the table below:

Icon	Meaning
	All the functional units making up the application (and related devices) are enrolled VIA BUS and configured correctly
	At least one functional unit making up the application relates to a device enrolled VIA CATALOGUE
	At least one functional unit making up the application relates to a device enrolled VIA BUS and being configured
	At least one functional unit making up the application (or its device) is enrolled VIA BUS and is in configuration error status
	At least one functional unit making up the application relates to a device enrolled VIA BUS which proves to be faulty during a diagnostics task

Click on the status icon to display the list of devices for which at least one functional unit is configured within the application.

Clicking on "UPDATE APPLICATIONS"  refreshes the page and updates the status icons.

Click on  to display the detailed screen of the specific application.

Click on  to delete the application.

Configuration with View Pro App

4.3.1 Example of ACCESSES AND PRESENCES application creation

Click on  to select the environment with which to pair the application, select ACCESSES AND PRESENCES and then click on .

The following types of application can be defined in the ACCESSES AND PRESENCES category:

- **CONTACT**, to display the status of an access (for instance, whether a window is open or closed); in this case, insert the functional unit of the contacts interface the magnetic contact is connected to in the application.
- **WINDOWS AND DOORS** and **GATE AND GARAGE**, to perform a control (for instance opening a door by activating the electrical lock or opening/closing a gate); in this case, insert the functional units of the buttons and relays that need to control the door or gate in the application. The two options are identical but the decision was made to differentiate them so that the end user can identify them immediately in the View App and on the touch screens.
- **PRESENCE IN ROOM**, to define an application to check the presence status in a hotel room; see section 4.4.11 for further details
- **ROOM STATUS SIGNAL**, to define an application to check the signal statuses of a hotel room (do not disturb, make up room, etc.); see section 4.4.10 for further details
- **CUSTOMISED WIDGET**, to create an application with virtual datapoints in order to interact with a KNX system; this application generates a dedicated screen on the touch screens for the management of the virtual datapoints in order to control the KNX system.

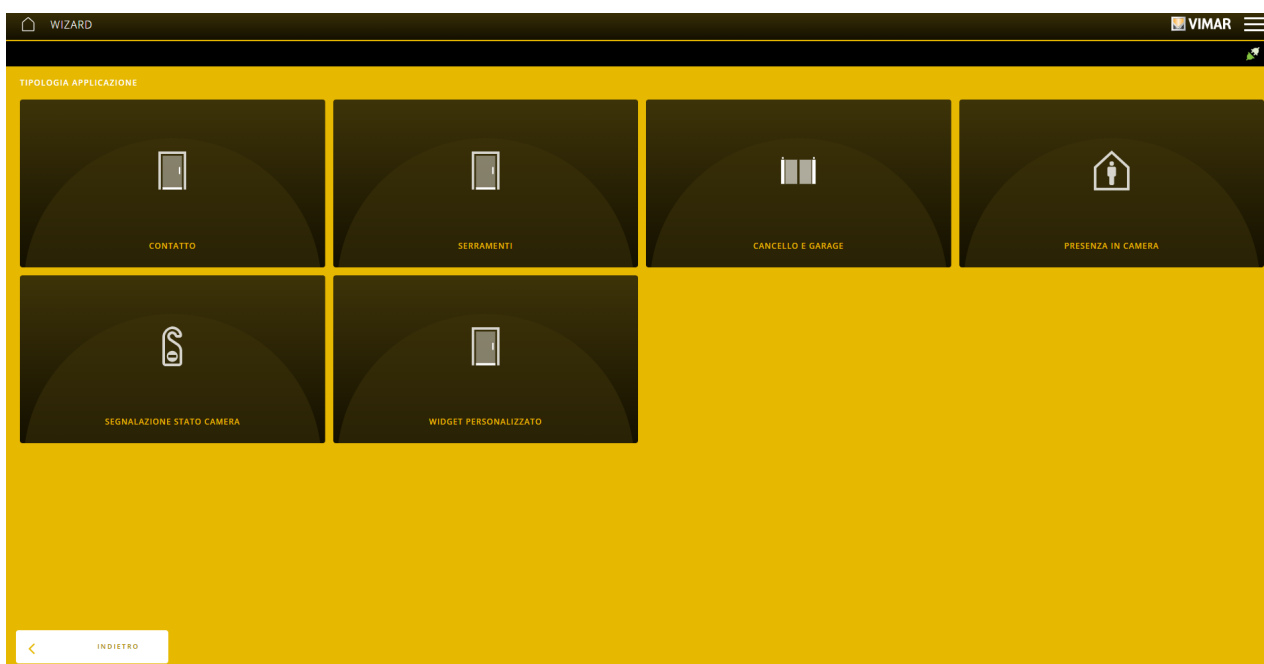

In this example, a CONTACT application has been created; the screen displayed allows you to select the contacts interface to which the magnetic contact whose status you wish to view is connected.

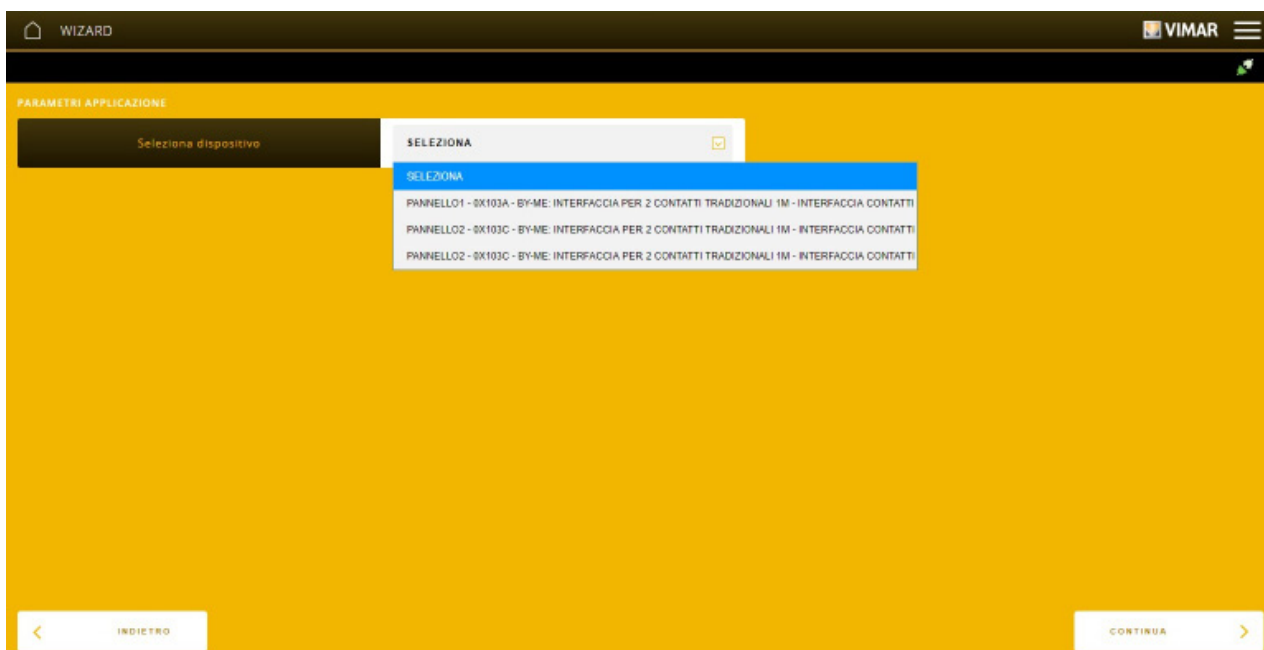

Configuration with View Pro App

Once the setting has been made, select "CONTINUE"; you will be prompted to enter the name that identifies the application within the environment. **We recommend you assign an unequivocal name that is easy to identify among all the devices in the system (useful to speed up diagnostics tasks, maintenance, etc.).**



Click on "END"; the screen displayed shows the functional unit of the contacts interface. The application will allow you to view the status of the contact paired with it.

4.3.2 Example of CURTAINS AND ROLLER SHUTTERS application creation

Click on  to select the environment with which to pair the application, select CURTAINS AND ROLLER SHUTTERS and then click on .

The screen displayed shows all the various types of management available; simply insert the buttons and relays with which to control the roller shutters or slats into the application.

The ROLLER SHUTTERS MASTER GROUP option creates an application allowing the simultaneous control of actuators already configured in other applications; see section 4.4.9 for further details.

The CUSTOMISED WIDGET option creates an application with virtual datapoints to interact with a KNX system; this application generates a dedicated screen on the touch screens for the management of the virtual datapoints in order to control the KNX system.

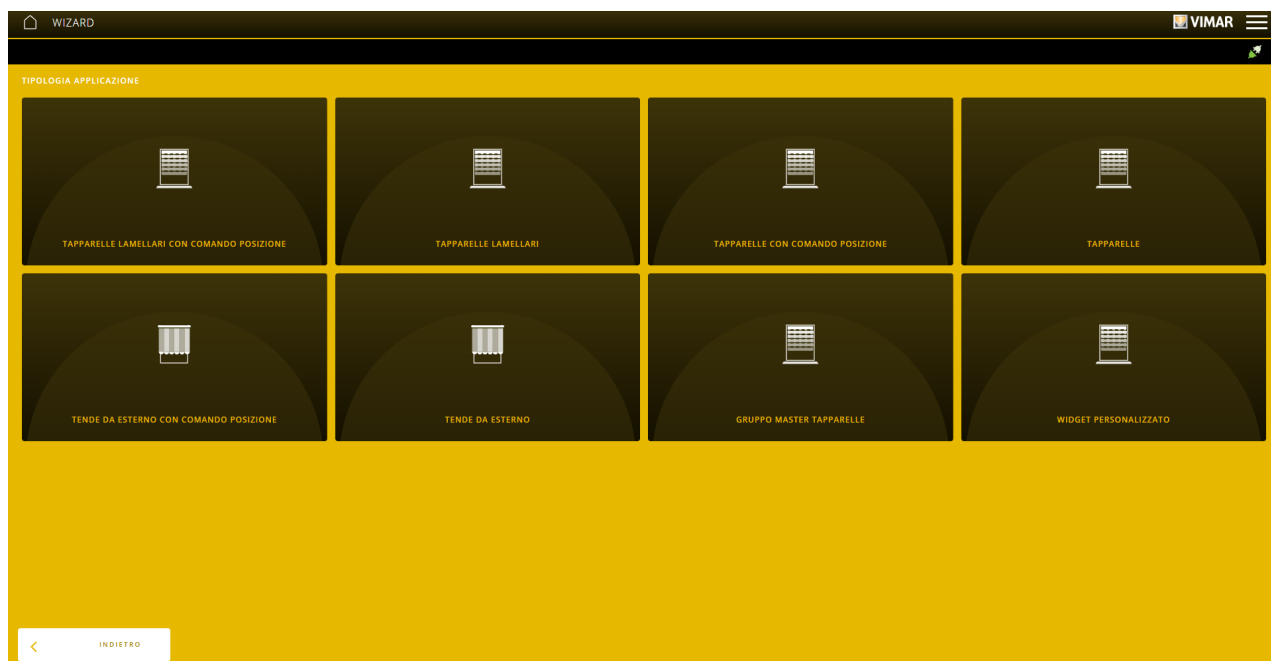

In this example, an OUTDOOR BLIND application has been created; you will be prompted to enter the name that identifies the application within the environment. **We recommend you assign an unequivocal name that is easy to identify among all the devices in the system (useful to speed up diagnostics tasks, maintenance, etc.).**



Click on "END".

Configuration with View Pro App

The screen of the application you just created is displayed; click on  and insert the functional units of the button and relay that will be controlling the blind.

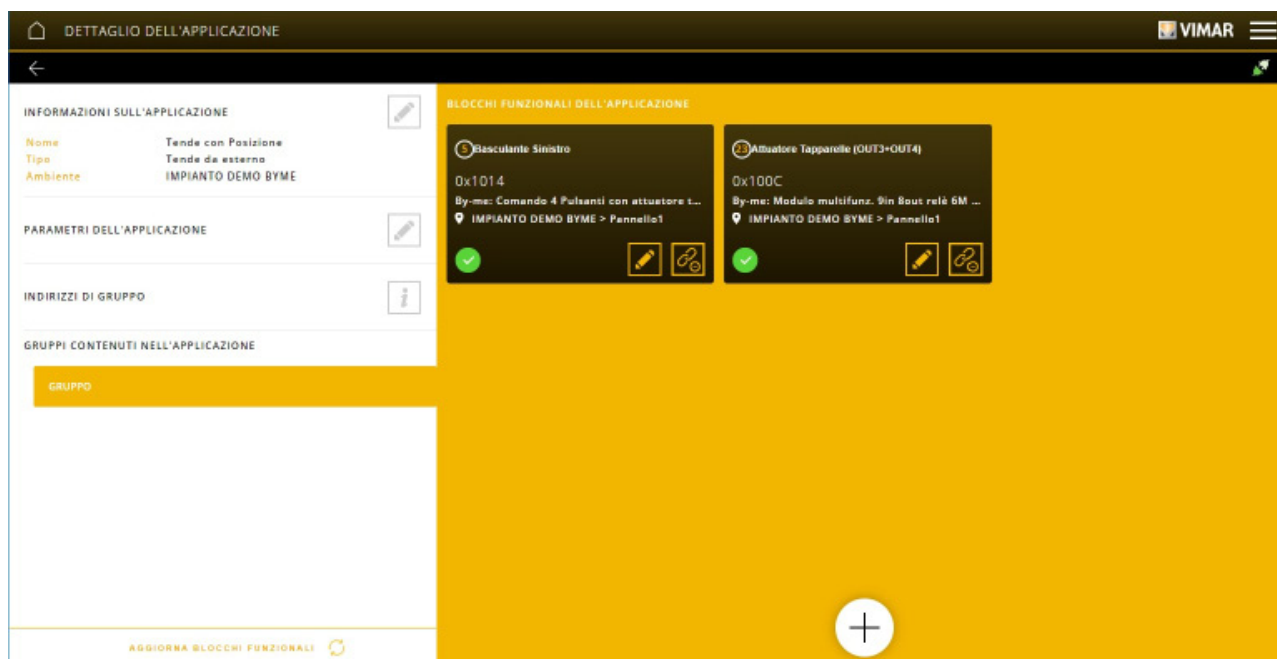

The application is now complete; press the left rocker button to control the roller shutter actuator relay of the inputs/outputs module 01470.1.

4.3.3 Example of LIGHTS application creation

Click on  to select the environment with which to associate the application, select LIGHTS and then click on .

The following types of application can be defined in the LIGHTS category:

- AUTOMATIC BRIGHTNESS CONTROL, to create an application with lights that automatically adjust their brightness according to the environmental brightness.
- WHITE LIGHT DIMMING, for dimmable monochrome lights.
- COLOURED (RGB) LIGHT DIMMING, for RGB/RGBW type coloured lights.
- TUNABLE WHITE LIGHT DIMMING, for lights with brightness and colour temperature control.
- ON – OFF, for on/off type lights (also configurable in one-position stable mode).
- TIMED ON – OFF, for lights that simultaneously provide the opportunity to be controlled as one-position stable and two-position stable via controls configured in the application. In the View App and in the touch screens, there is only one control mode (chosen during the configuration wizard).
- TIMED DIMMER ON – OFF, for dimmable monochrome lights that simultaneously provide the opportunity to be controlled as one-position stable and two-position stable via controls configured in the application. In the View App and in the touch screens, there is only one control mode (chosen during the configuration wizard).
- TIMED TUNABLE WHITE DIMMER ON – OFF, for lights with colour temperature and brightness control that simultaneously provide the opportunity to be controlled as one-position stable and two-position stable via controls configured in the application. In the View App and in the touch screens, there is only one control mode (chosen during the configuration wizard)
- PHILIPS HUE, for “Philips Hue lamp” type actuators; see section 4.3.3.1 for further details.
- DALI-2, to create the same types of applications already described (ON-OFF, MONOCHROME DIMMER, TUNABLE WHITE DIMMER, RGB/RGBW DIMMER) but using DALI-2 actuators; see paragraph 4.7 for further information.
- LIGHTS MASTER GROUP, to create an application that allows the simultaneous control of actuators that have already been configured in other applications, even of different types (By-me Plus, DALI-2, Philips Hue) or configurations (on/off, dimmer, RGB dimmer, etc.); see section 4.4.9 for further details
- CUSTOMISED WIDGET, to create an application with virtual datapoints in order to interact with a KNX system; this application generates a dedicated screen on the touch screens for the management of the virtual datapoints in order to control the KNX system.

Configuration with View Pro App

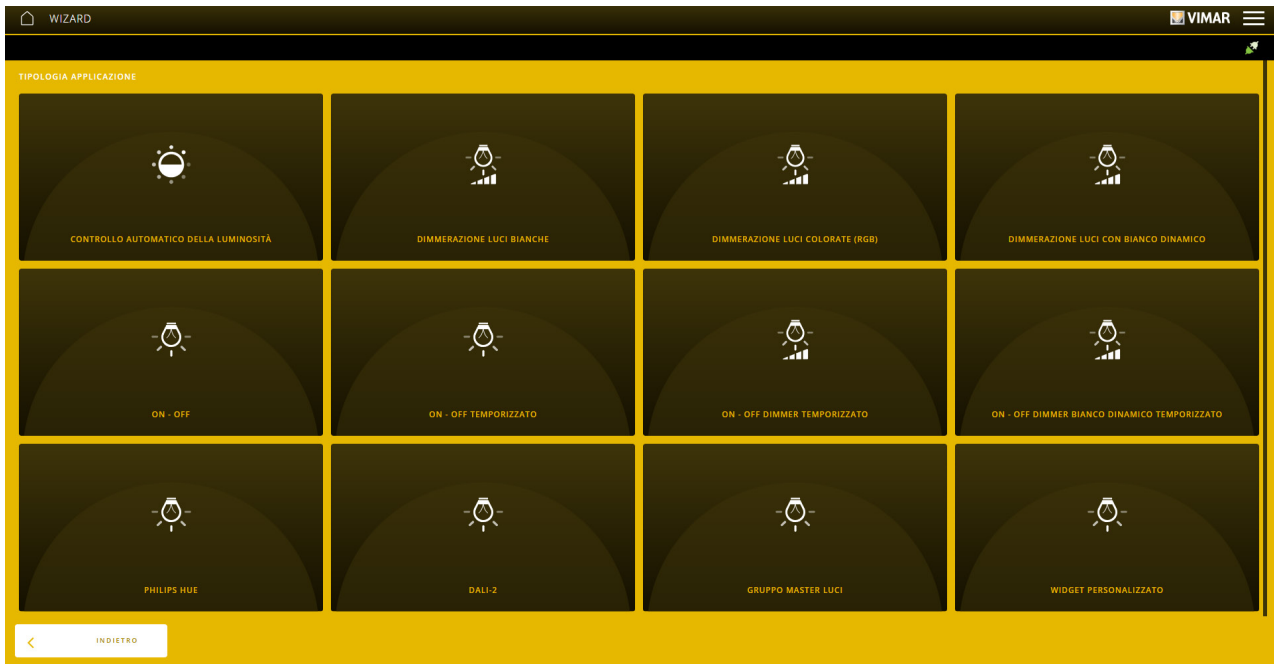

In the following example, a WHITE LIGHT DIMMING application is being created; you will be prompted to enter the name that identifies the application within the environment. We recommend you assign an unequivocal name that is easy to identify among all the devices in the system (useful to speed up diagnostics tasks, maintenance, etc.).

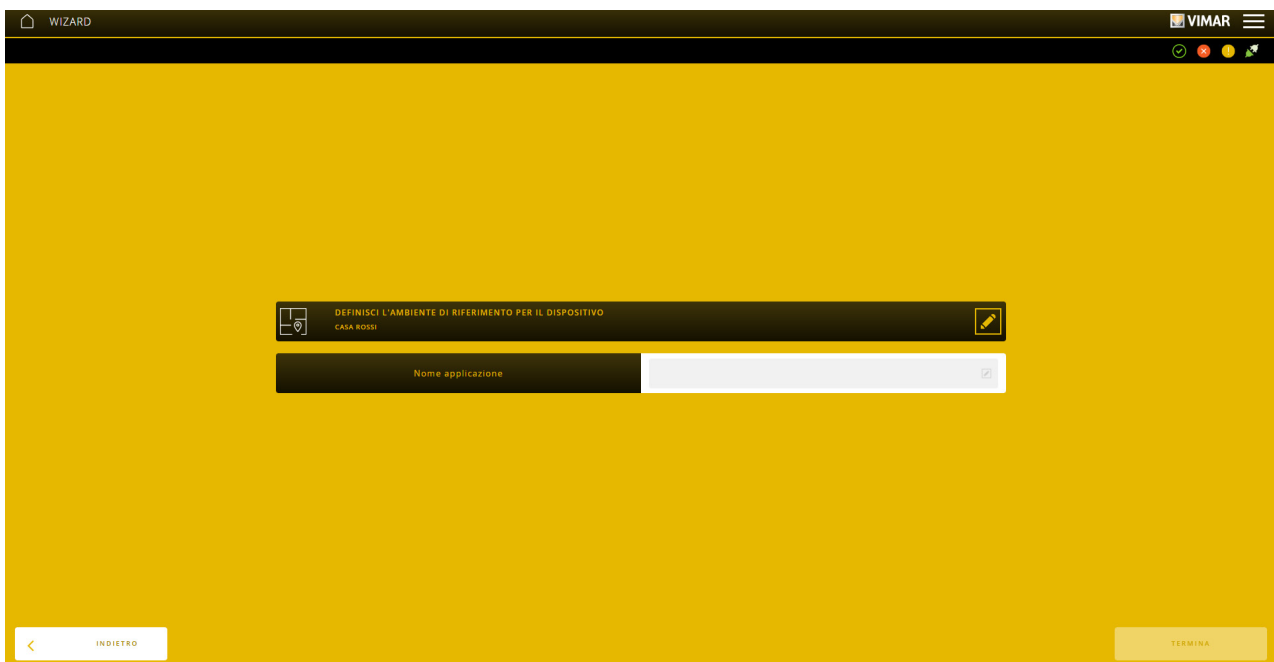

Click on "END".

The screen of the application you just created is displayed; click on  and insert the functional units of the buttons and actuators that will be controlling the light.

4.3.3.1 LIGHTS applications with Philips Hue lamps.

Philips Hue lamps with Friends of Hue standard can be managed within the LIGHTS applications in the same way illustrated in the previous example.

Communication with the By-me Plus system takes place via a Bridge that the Administrator needs to authorise via his or her own View App and with which he or she will then have to name each lamp, inserting it in the desired environment and choosing whether to manage it as an individual lamp or as part of groups of lamps (see the View App manual). For the Installer to be able to create the applications, the Administrator first needs to perform the Bridge authorisation operations and the lamp pairings.

Configuration with View Pro App

Select PHILIPS HUE to display the screen allowing the setting of the function that the lamp can carry out (compatibly with those supported).

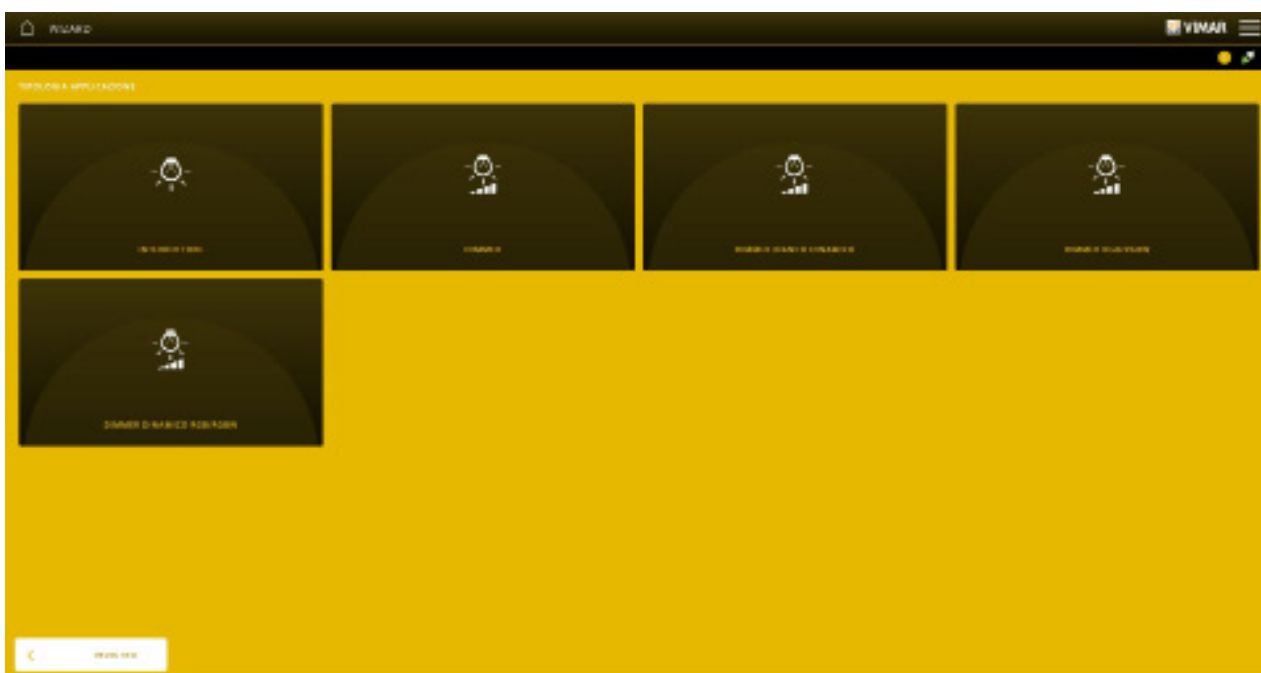

Once the function (and related parameters) has been assigned to each lamp, the various applications then need to be created.

4.3.4 Example of MUSIC AND AUDIO application creation

Click on to select the environment with which to pair the application, select MUSIC AND AUDIO and then click on .

The screen displayed allows you to define the functions to carry out both at device level (AUDIO SOURCE) and audio zone to manage (AUDIO ZONE) and allows you to manage vocal announcements (MICROPHONE MODULE). The CUSTOMISED WIDGET option creates an application with virtual datapoints to interact with a KNX system; this application generates a dedicated screen on the touch screens for the management of the virtual datapoints in order to control the KNX system.

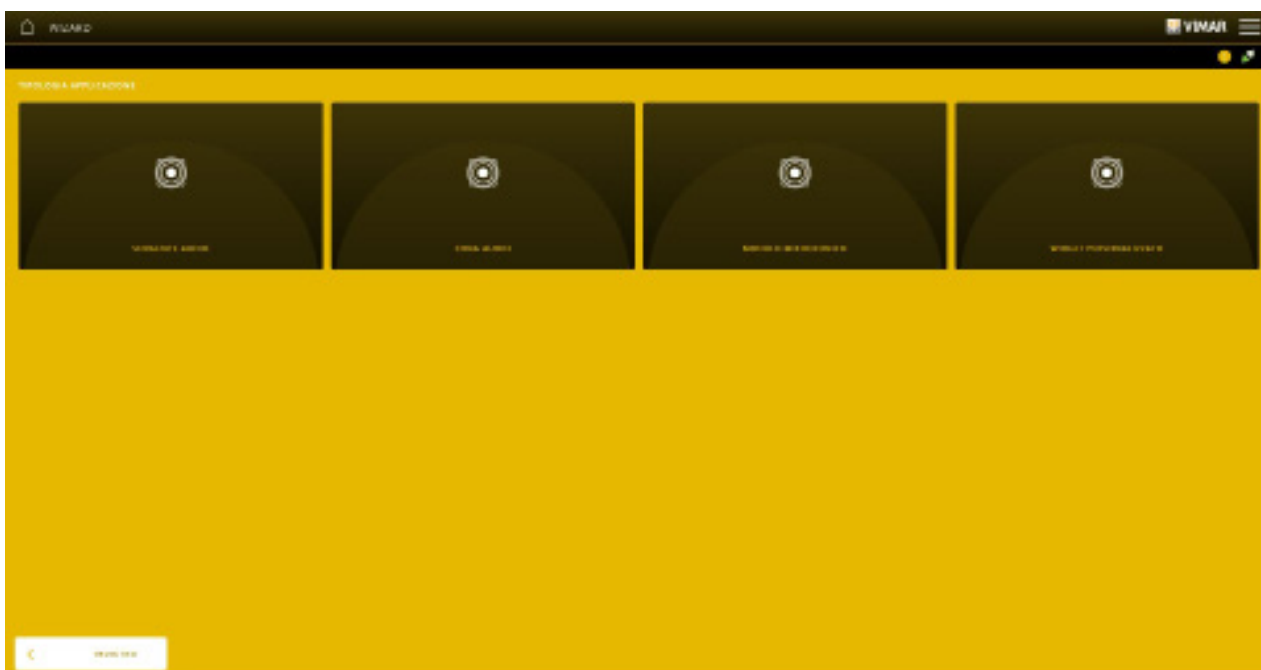

Select AUDIO SOURCE; the audio sources relating to the devices in the sound system range are displayed.

Configuration with View Pro App

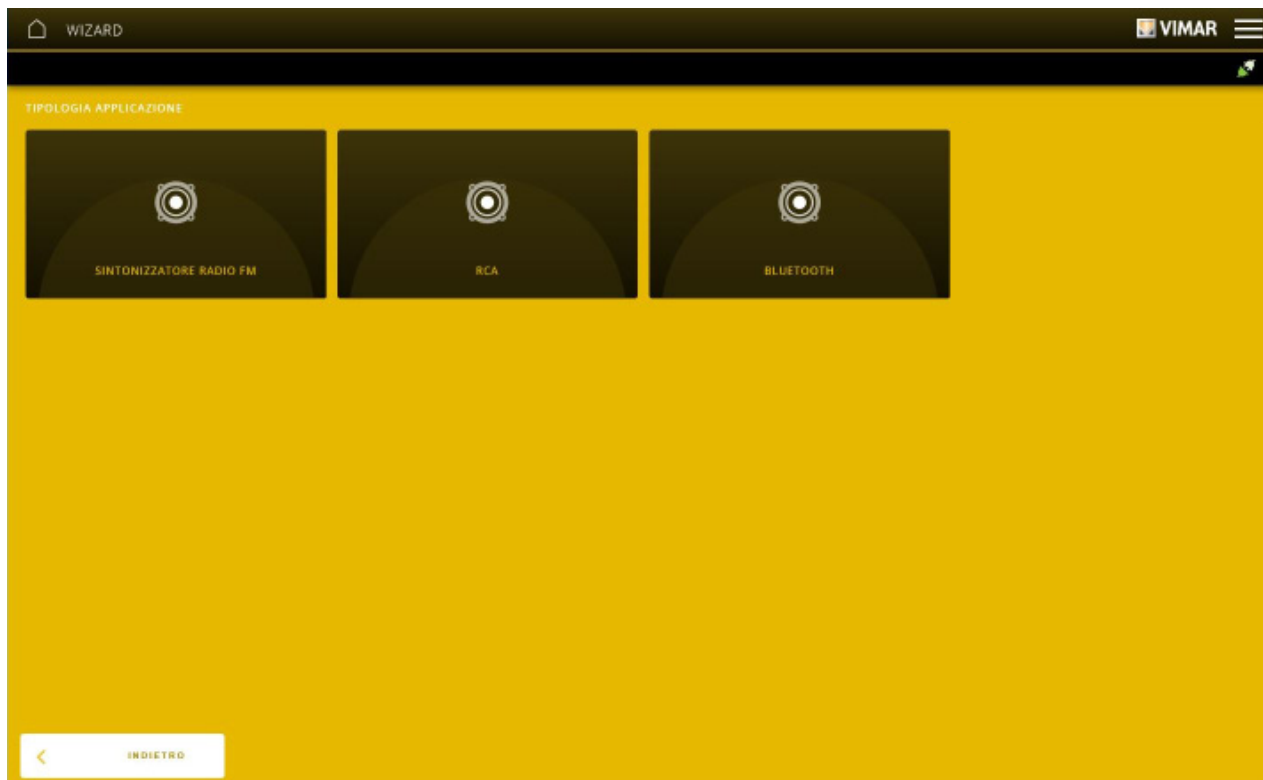

In this example, a radio tuner 01900 is configured; select FM RADIO TUNER.

You will then be prompted to select, using the drop-down menu, the FM radio tuner device you previously enrolled.

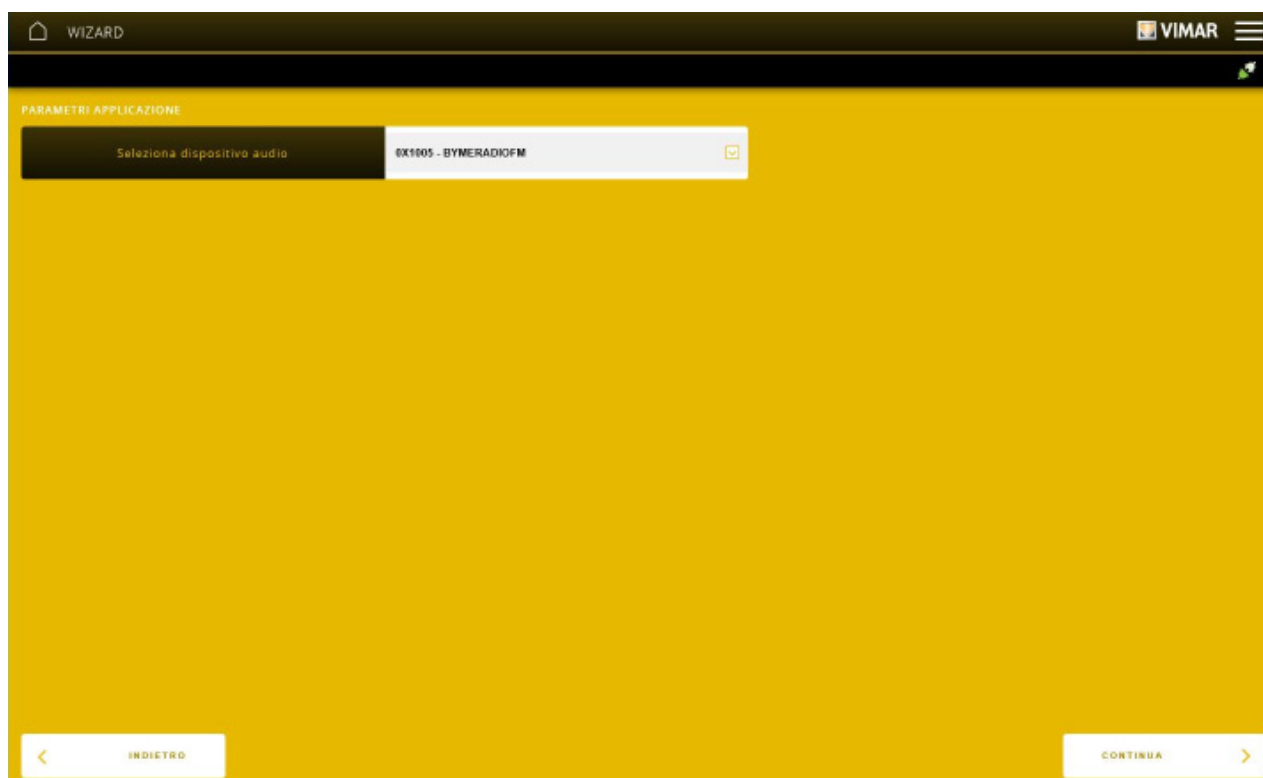

Select "CONTINUE"; you will be prompted to enter the name that identifies the application within the environment. **We recommend you assign an unequivocal name that is easy to identify among all the devices in the system (useful to speed up diagnostics tasks, maintenance, etc.).**

Click on "END"; the screen displayed is where the functional units of the devices are paired with the application.

Configuration with View Pro App

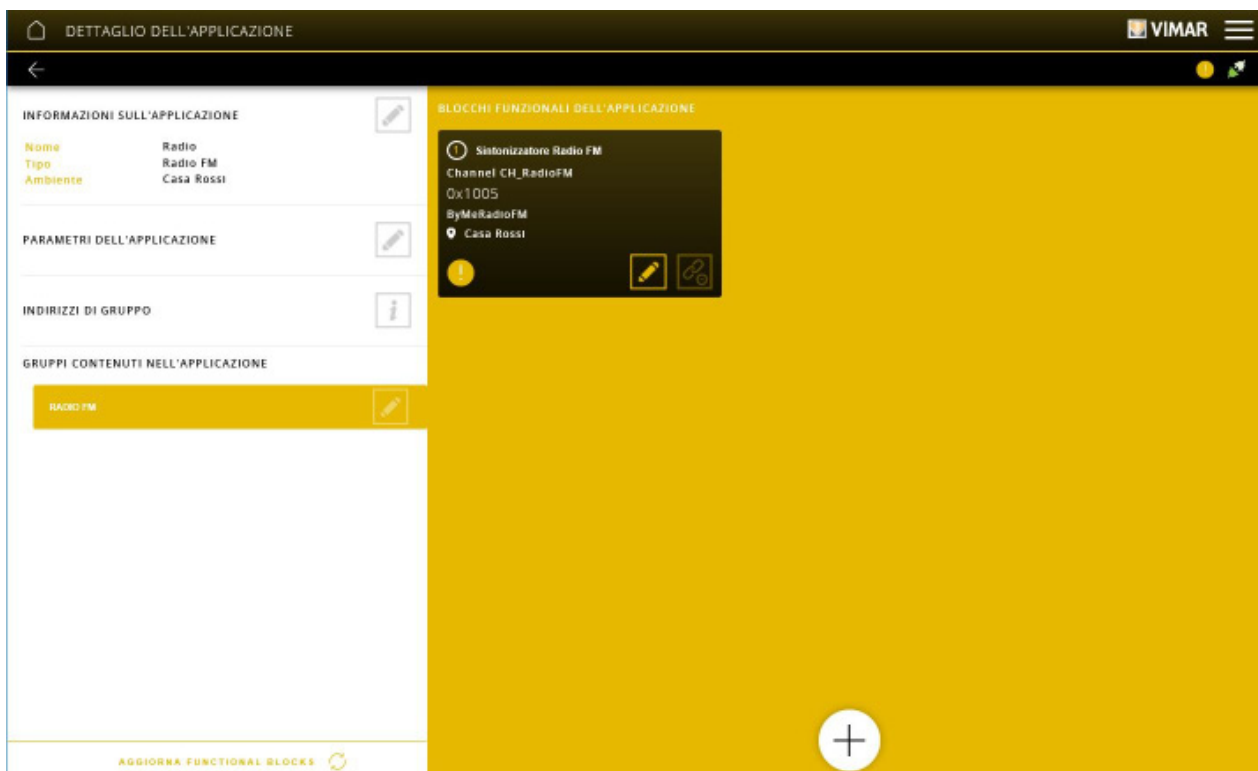

In the screen allowing you to define the functions to carry out, select AUDIO ZONE. You will then be prompted to select, using the drop-down menu, the device through which to control the audio signal (in this example, the home automation system control device 30484-01484).

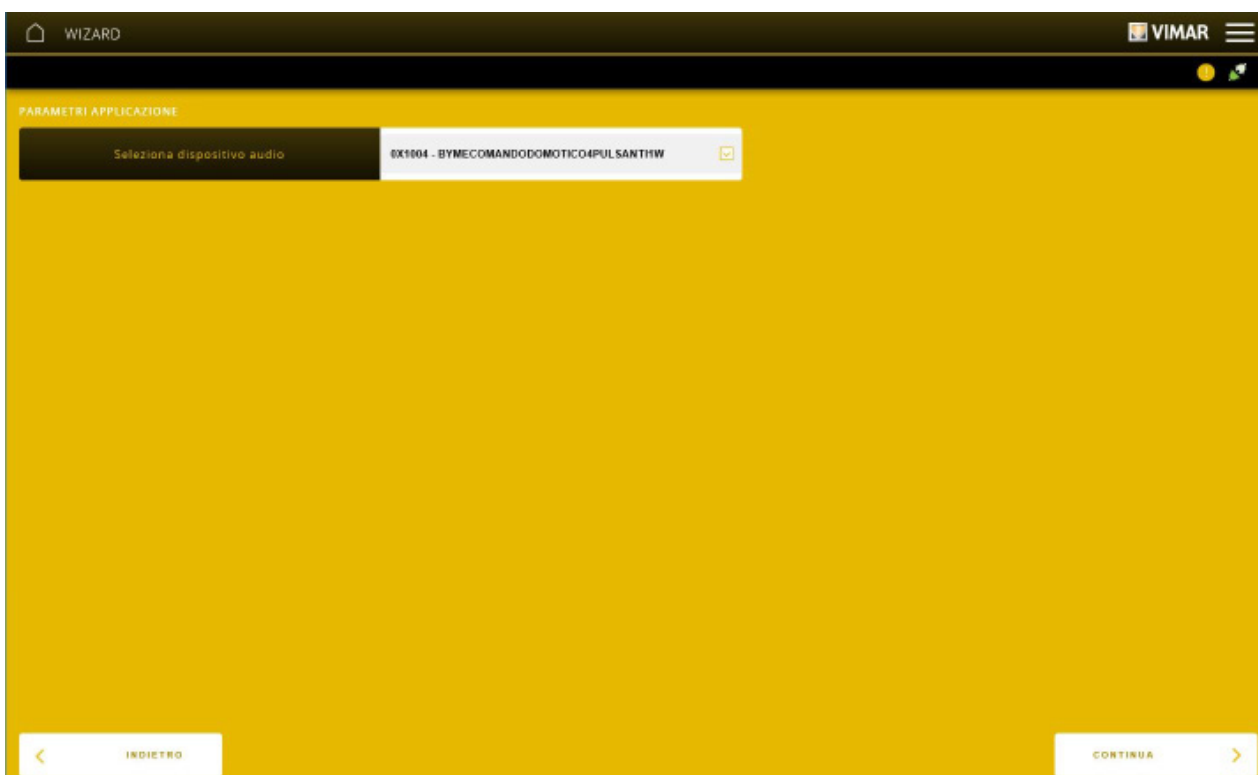



Select "CONTINUE"; you will be prompted to enter the name that identifies the application within the environment. **We recommend you assign an unequivocal name that is easy to identify among all the devices in the system (useful to speed up diagnostics tasks, maintenance, etc.).**

Click on "END"; the screen displayed is where the functional units of the devices are paired with the application.

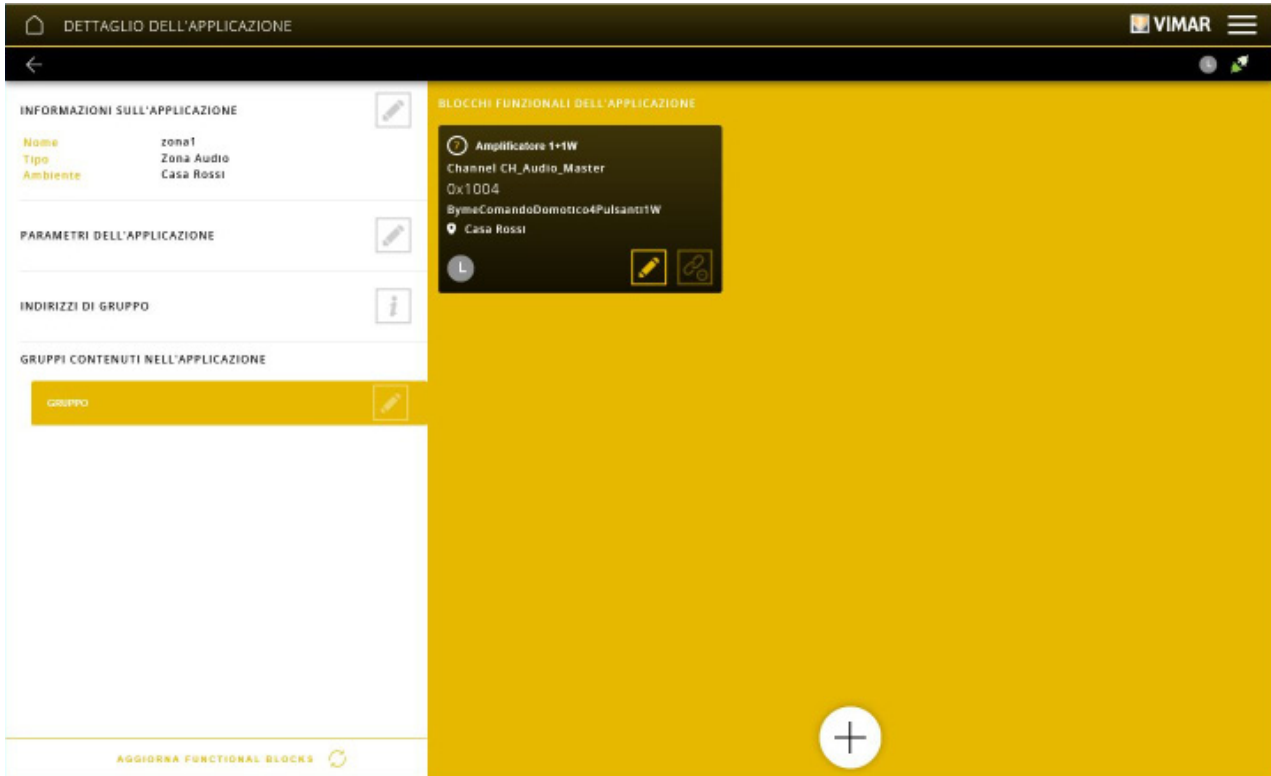
Configuration with View Pro App



4.3.5 Example of CLIMATE CONTROL application creation

Click on  to select the environment with which to pair the application, select CLIMATE CONTROL and then click on .

The screen displayed allows you to define whether the functions to carry out relate to the HVAC controller (HVAC CONTROLLER), to the temperature probe (SENSOR), to the thermostat (CLIMATE ZONE), etc. The CUSTOMISED WIDGET option creates an application with virtual datapoints to interact with a KNX system; this application generates a dedicated screen for the management of the virtual datapoints on the touch screens in order to control the KNX system.

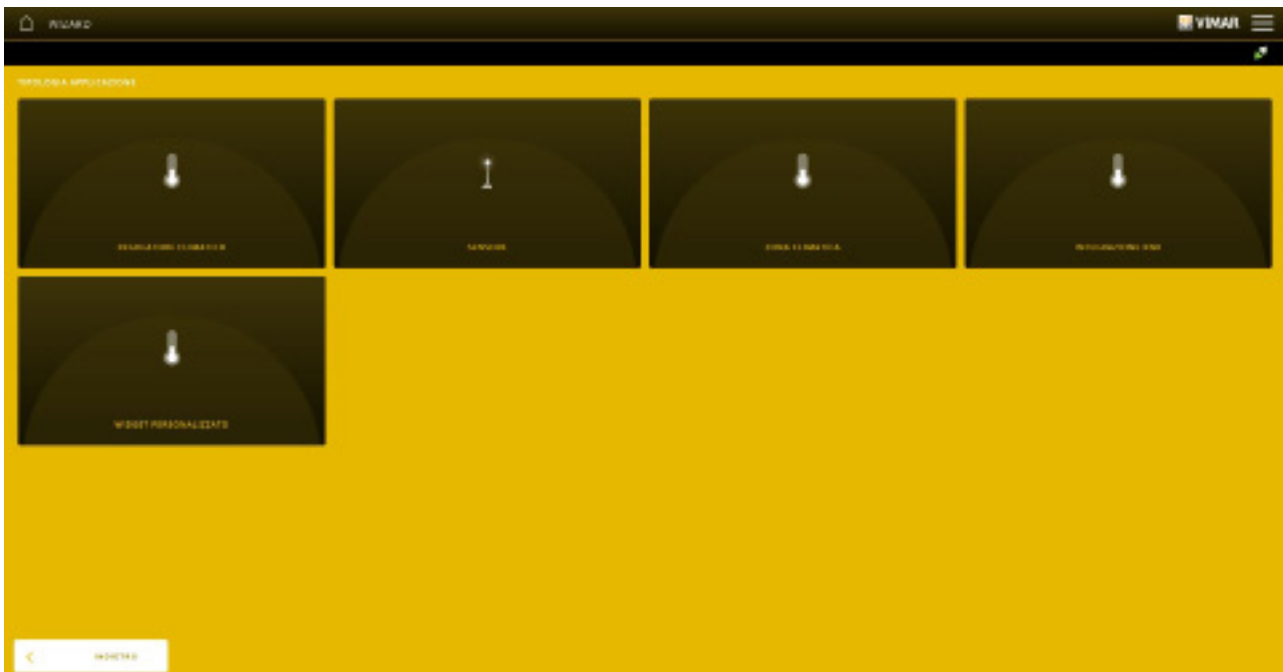

In this example, a thermostat is being configured.

Configuration with View Pro App

Select CLIMATE ZONE followed by BY-ME; the screen displayed allows you to choose the operating mode of the thermostat.

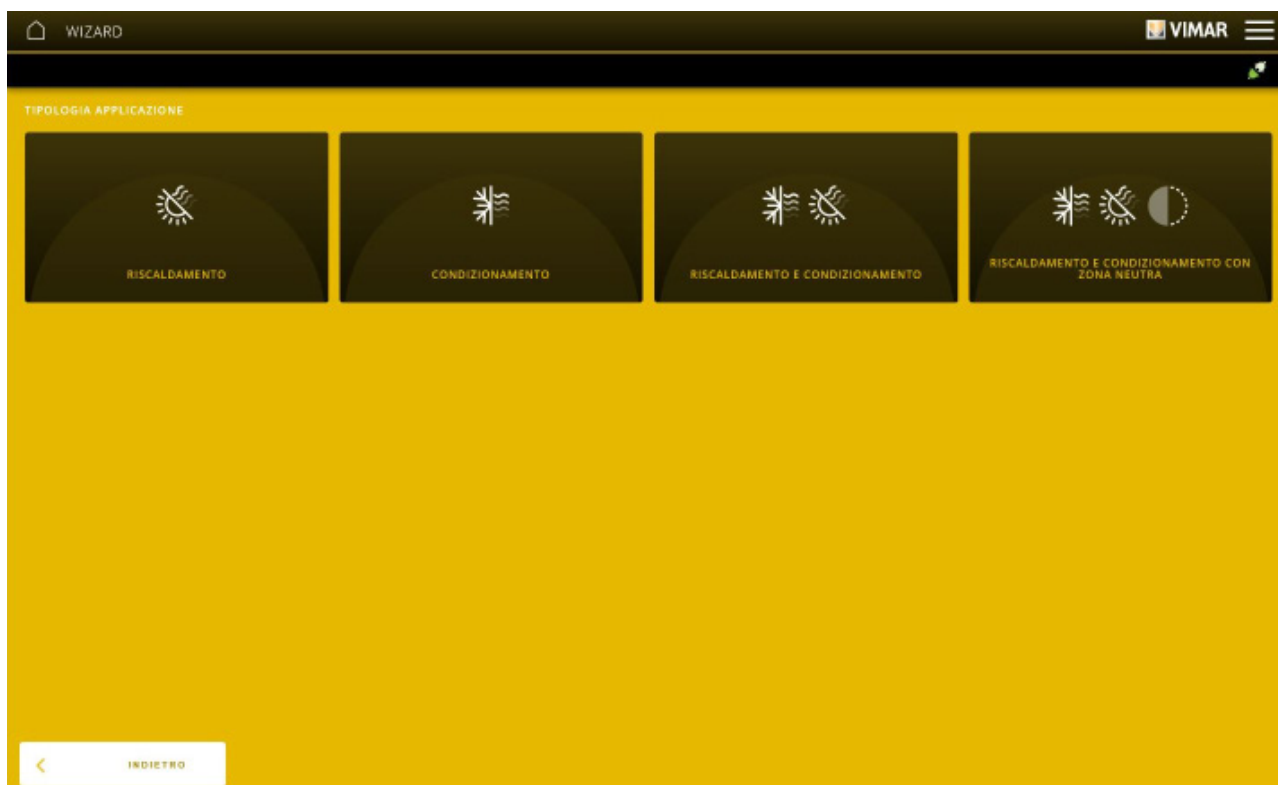

For example, select "HEATING AND AIR CONDITIONING"; the screen displayed allows you to set the functions and the types of actuator of the outputs controlled by the thermostat.

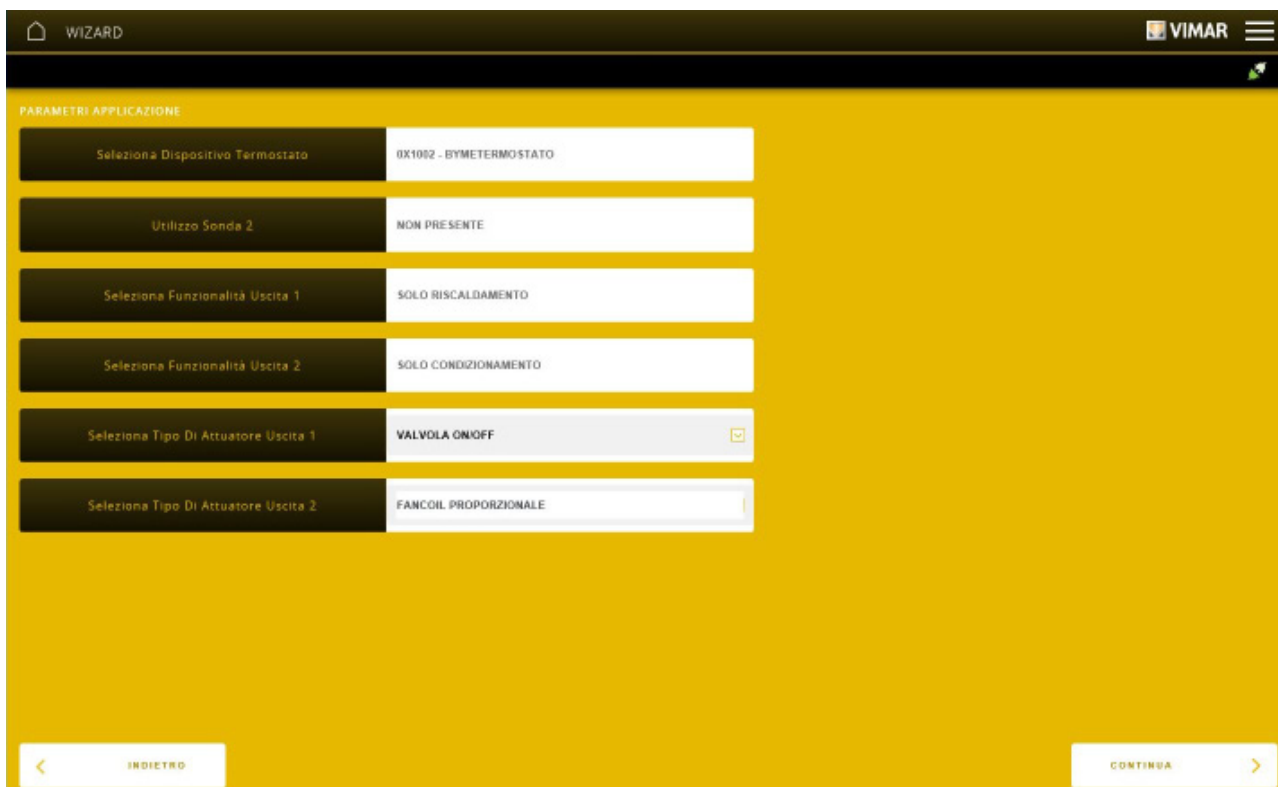

N.B. In the event that Use of Probe 2 has not been configured, this will no longer be possible at a later stage; you therefore need to configure the thermostat again, including the probe too.

Configuration with View Pro App

Once the settings have been made, select "CONTINUE"; you will be prompted to enter the name that identifies the application within the environment. **We recommend you assign an unequivocal name that is easy to identify among all the devices in the system (useful to speed up diagnostics tasks, maintenance, etc.).**

Click on "END"; the screen displayed is where the functional units of the devices are paired with the application.

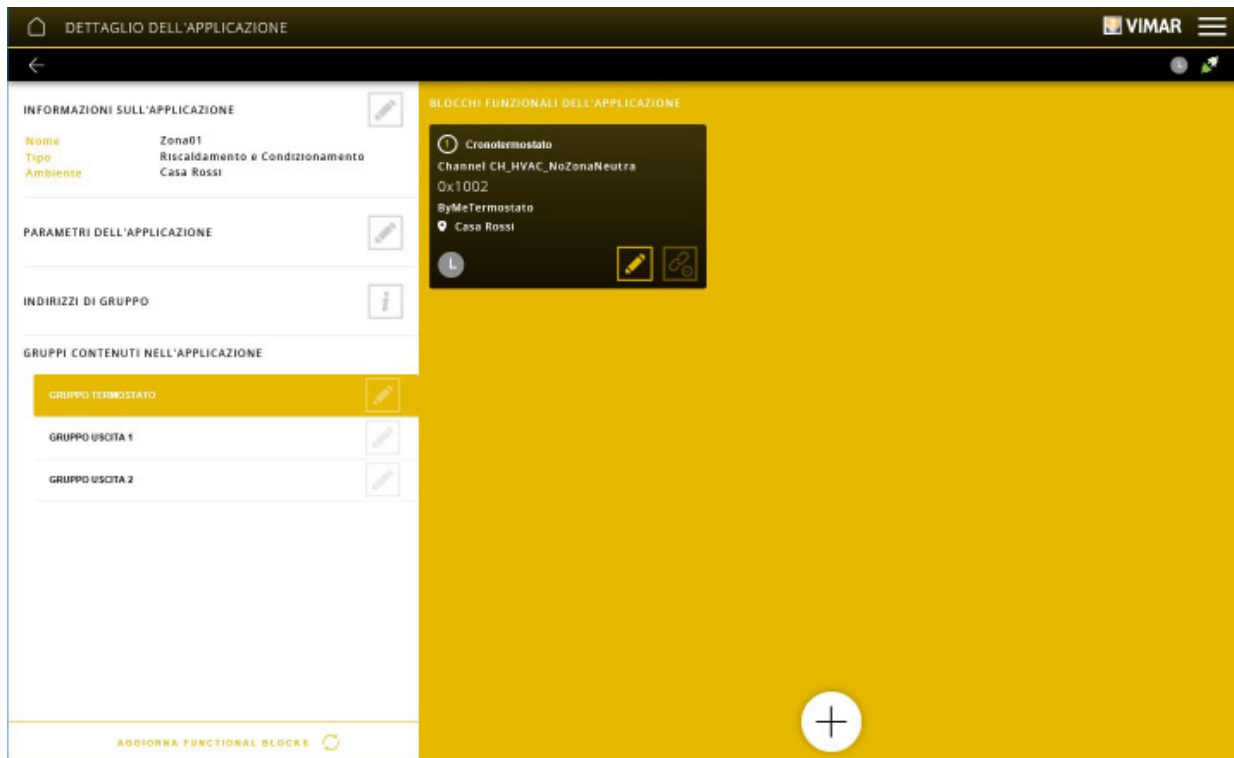



At this stage, within each group, you need to pair the functional units of the relay actuators (which control the temperature control system) you want the thermostat to control.

N.B. If the XT Multisensor art. 32042 is used in this application, the configuration wizard will display another step to carry out after choosing the configuration of the outputs, where you will be able to choose whether:

- to use the graphic interface of the device for the control/viewing of the thermostat
- to create a thermostat that can only be managed by supervisors and use the graphic interface of the device for other purposes (for instance signalling and/or controlling other applications).

4.3.6 Example of SENSORS application creation

Click on  to select the environment with which to pair the application, select SENSORS and then click on .

The following types of application can be defined in the SENSORS category:

- **VIEWING ONLY**, to create an application that displays the status and/or current value of a specific dimension measured by a sensor.
- **VIEW AND CONTROL**, to create an application that displays the status and/or current value of a specific dimension measured by a sensor and that controls one or more relays under specific conditions on a configurable threshold.
- **WEATHER STATION**, to create an application relating to device 01546; see paragraph 4.6 for further details.
- **CUSTOMISED WIDGET**, to create an application with virtual datapoints in order to interact with a KNX system; this application generates a dedicated screen on the touch screens for the management of the virtual datapoints in order to control the KNX system.

Configuration with View Pro App

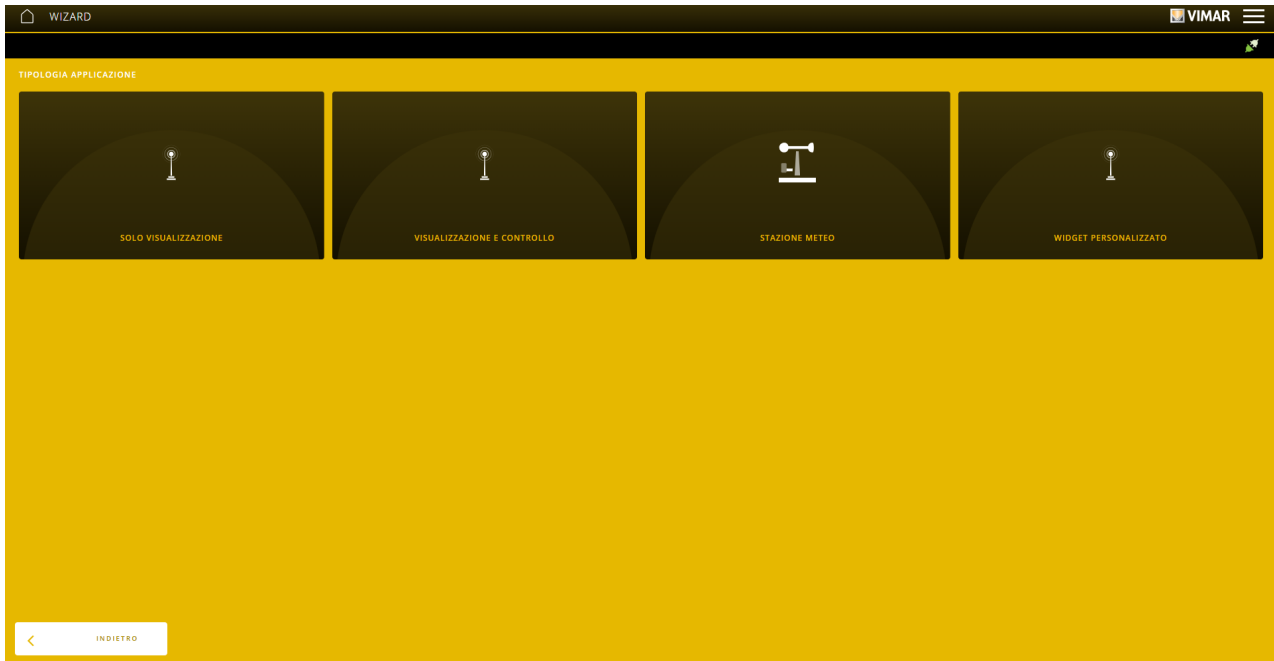

By selecting the type of function, the screen displayed allows you to define the sensor to configure among those available.

VIEW ONLY

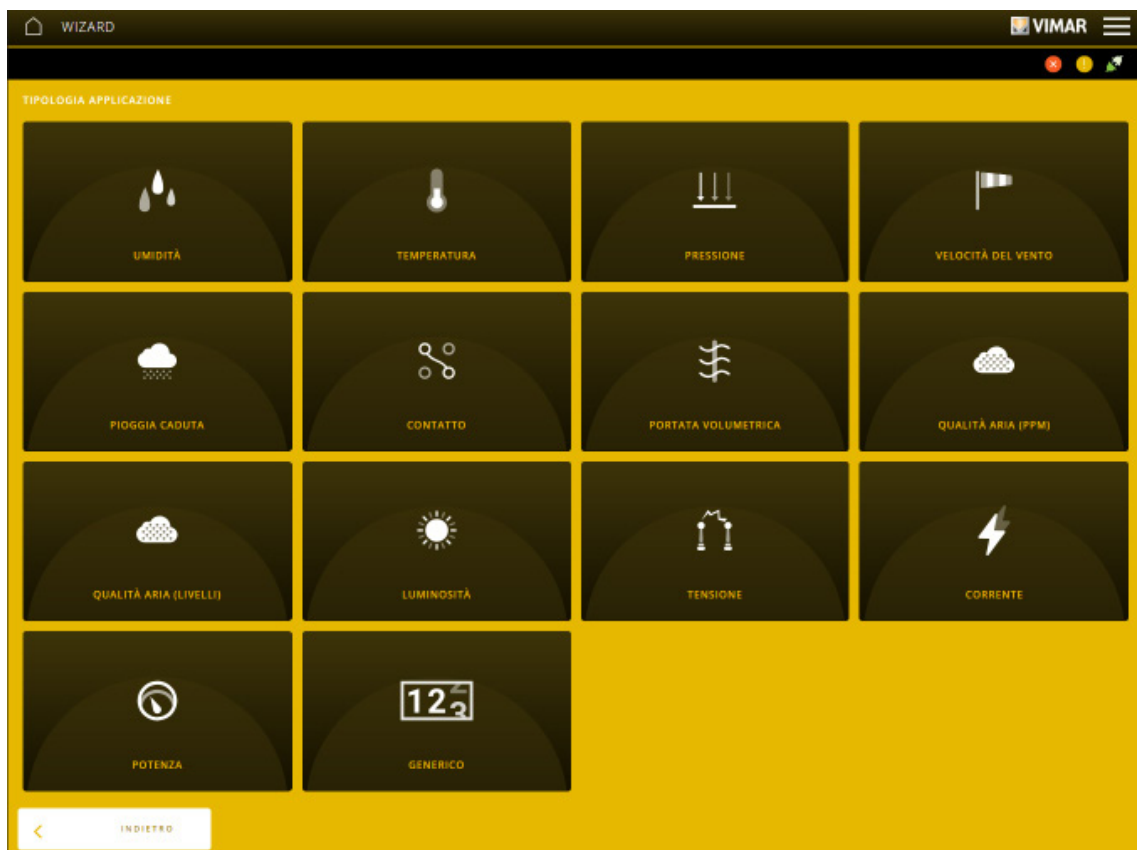

Configuration with View Pro App

VIEW AND CONTROL

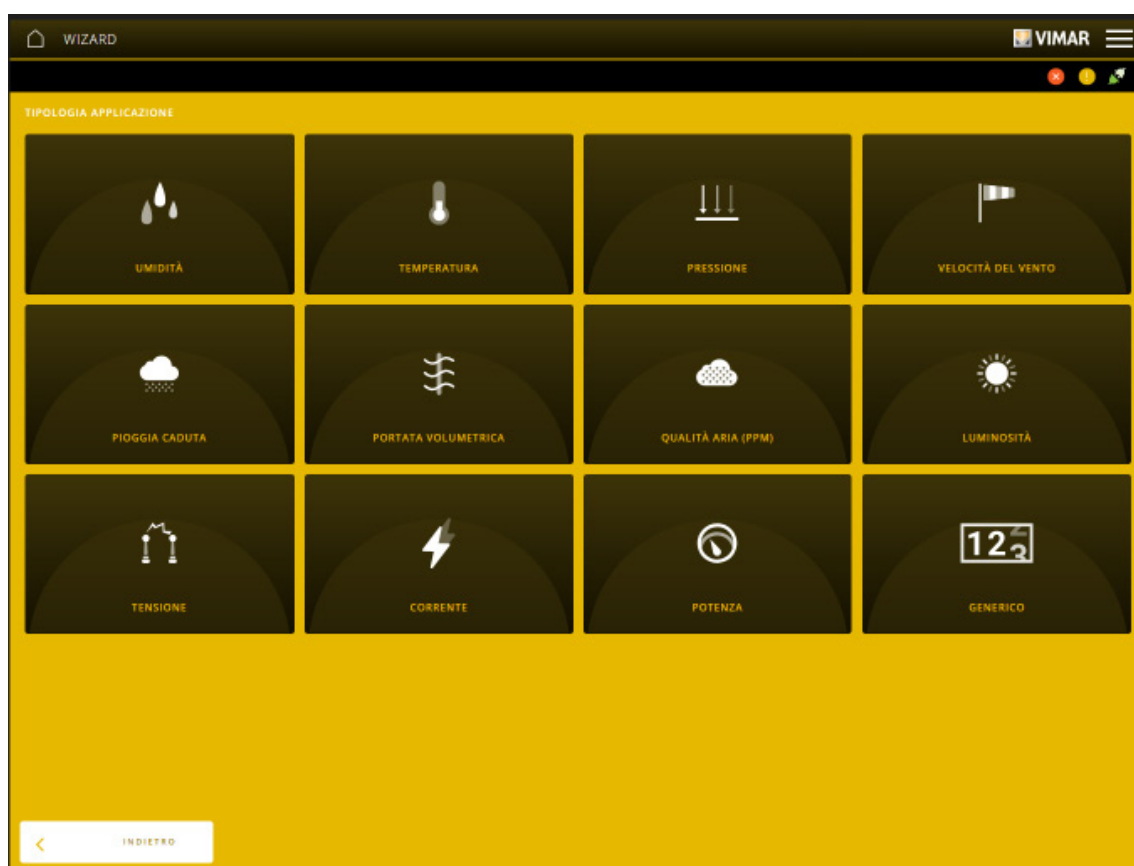

In this example, a humidity sensor is being configured.

Select HUMIDITY; the screen displayed allows you to choose the device (in this case module 01467) to which the sensor is connected.

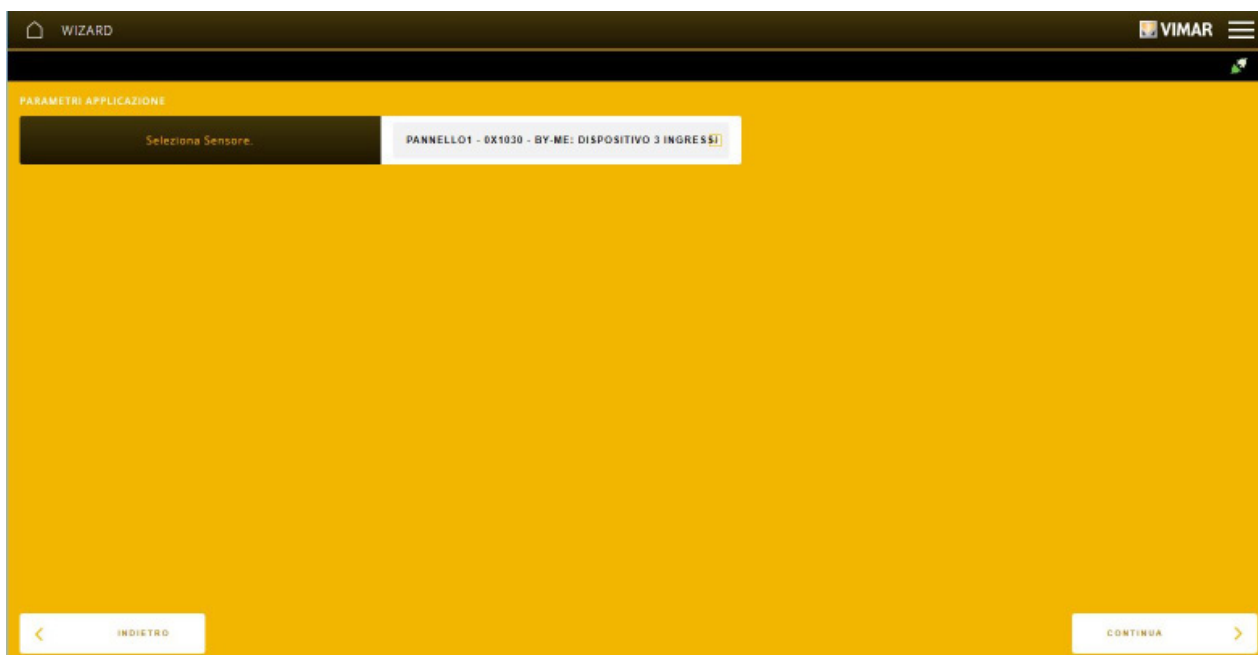

Select "CONTINUE"; you will be prompted to set the type (voltage and current) of input channel of the device consistently with the parameters set in sensor xx433.

Configuration with View Pro App

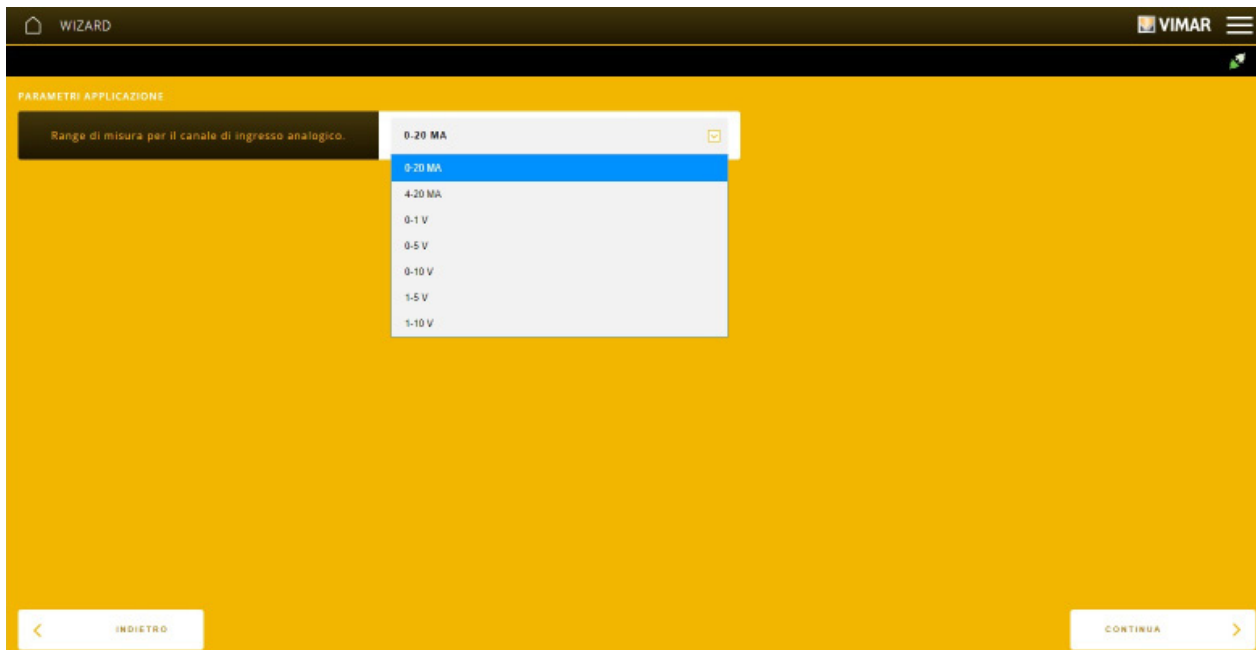

Once the setting has been made, select "CONTINUE"; you will be prompted to enter the name that identifies the application within the environment. **We recommend you assign an unequivocal name that is easy to identify among all the devices in the system (useful to speed up diagnostics tasks, maintenance, etc.).**



Click on "END"; the screen displayed shows the functional unit allowing the viewing of what has been detected by the sensor.

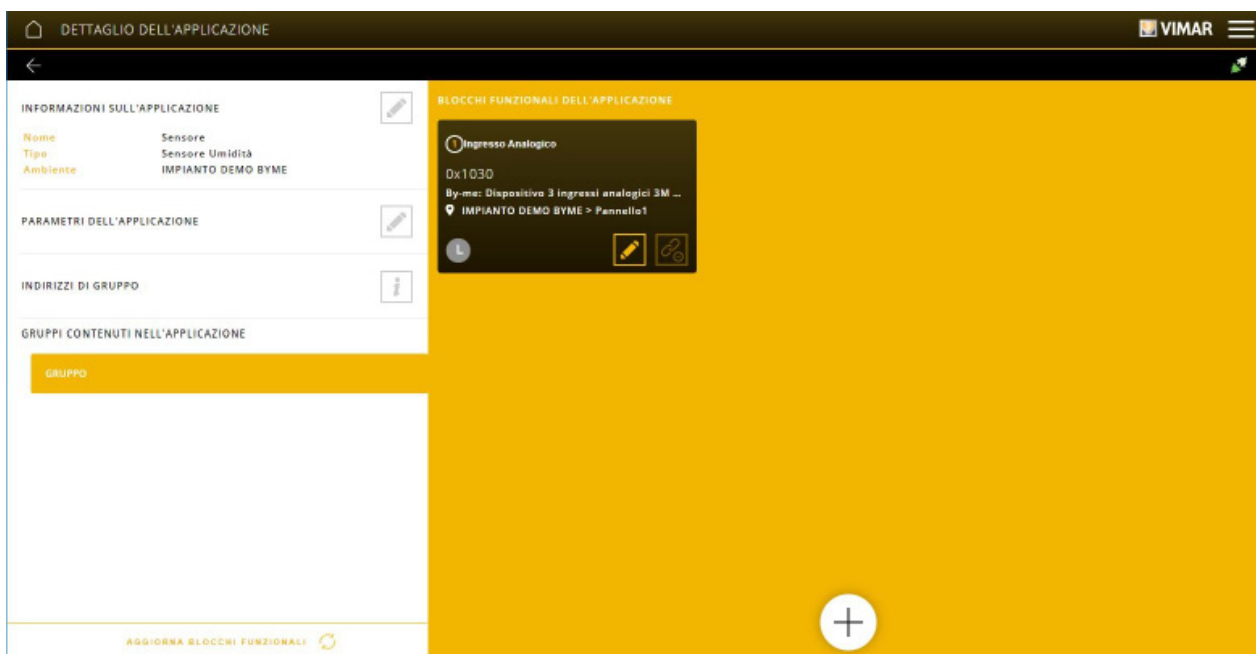

Should the type of function selected be VIEW AND CONTROL, you will need to insert the functional units of the devices performing the control within the above application, such as ON/OFF relay for the humidistat function.

Configuration with View Pro App

4.3.7 Example of ENERGY application creation

Click on to select the environment with which to pair the application, select ENERGY and then click on .

The screen displayed allows you to define whether the functions to carry out relate to the load control module 01455 (LOAD CONTROL), to the energy meter 01450 (SINGLE AND THREE PHASE METER), etc. The CUSTOMISED WIDGET option creates an application with virtual datapoints to interact with a KNX system; this application generates a dedicated screen for the management of virtual datapoints on the touch screens in order to control the KNX system.

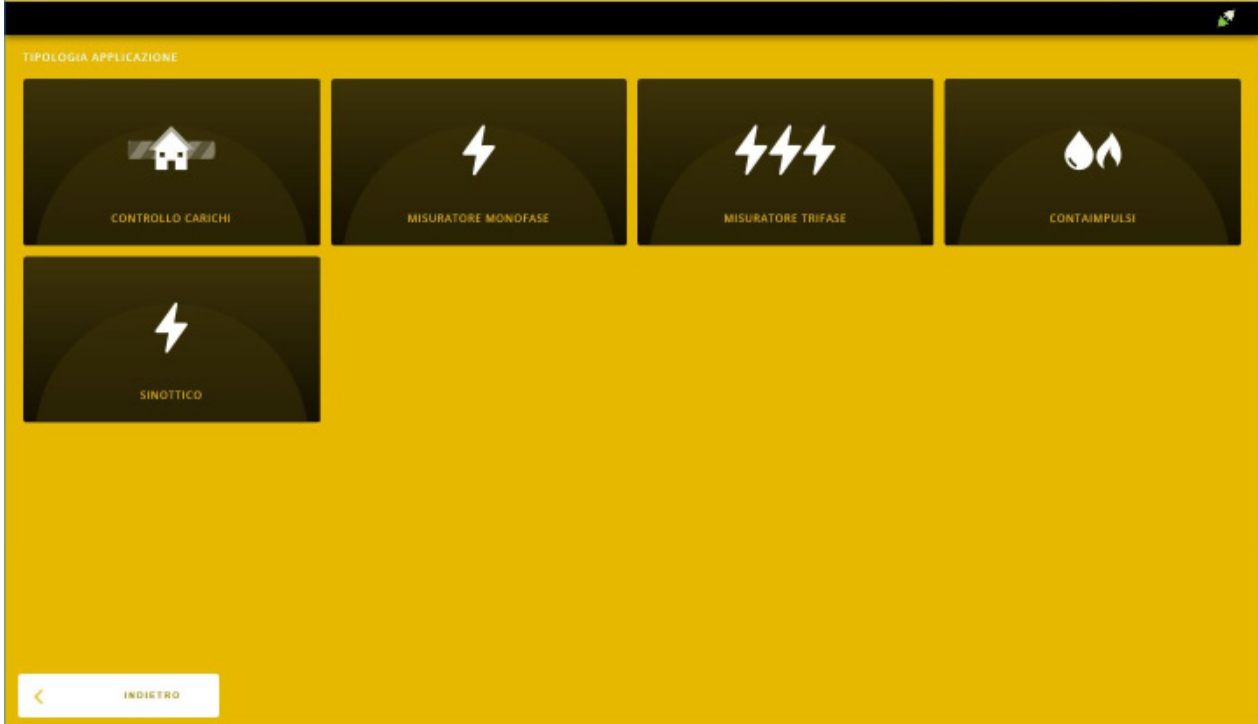

In this example, a load control module is being configured.

Select LOAD CONTROL; the screen displayed allows you to choose the type of loads.

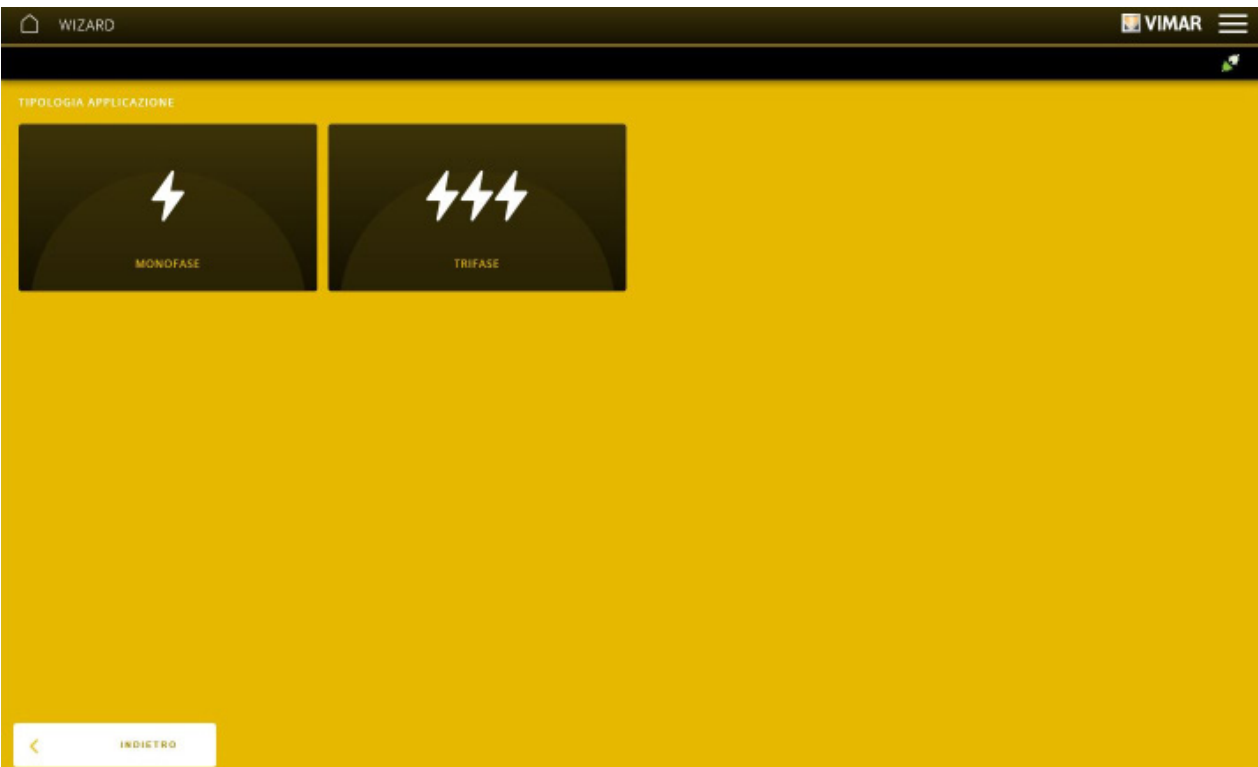

Configuration with View Pro App

- In the case of a single phase system the options will be as follows:

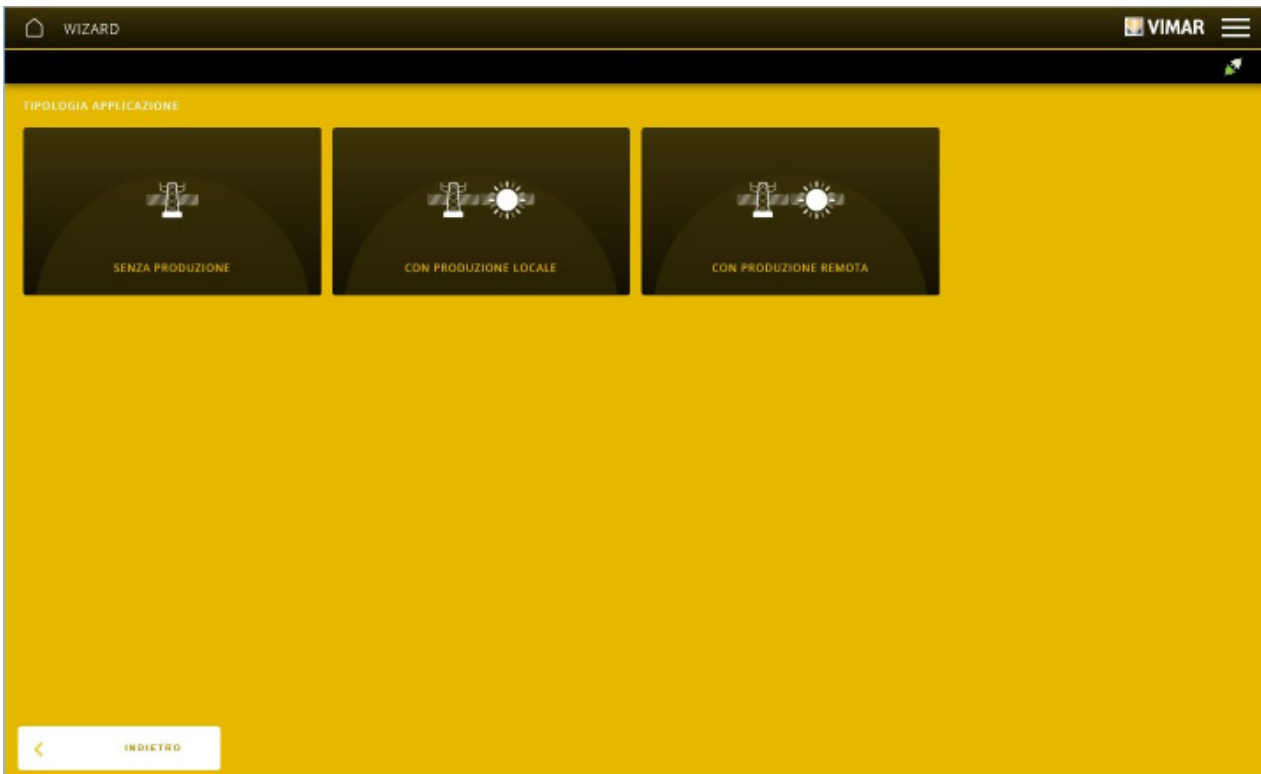

- In the case of a three phase system the options will instead be:

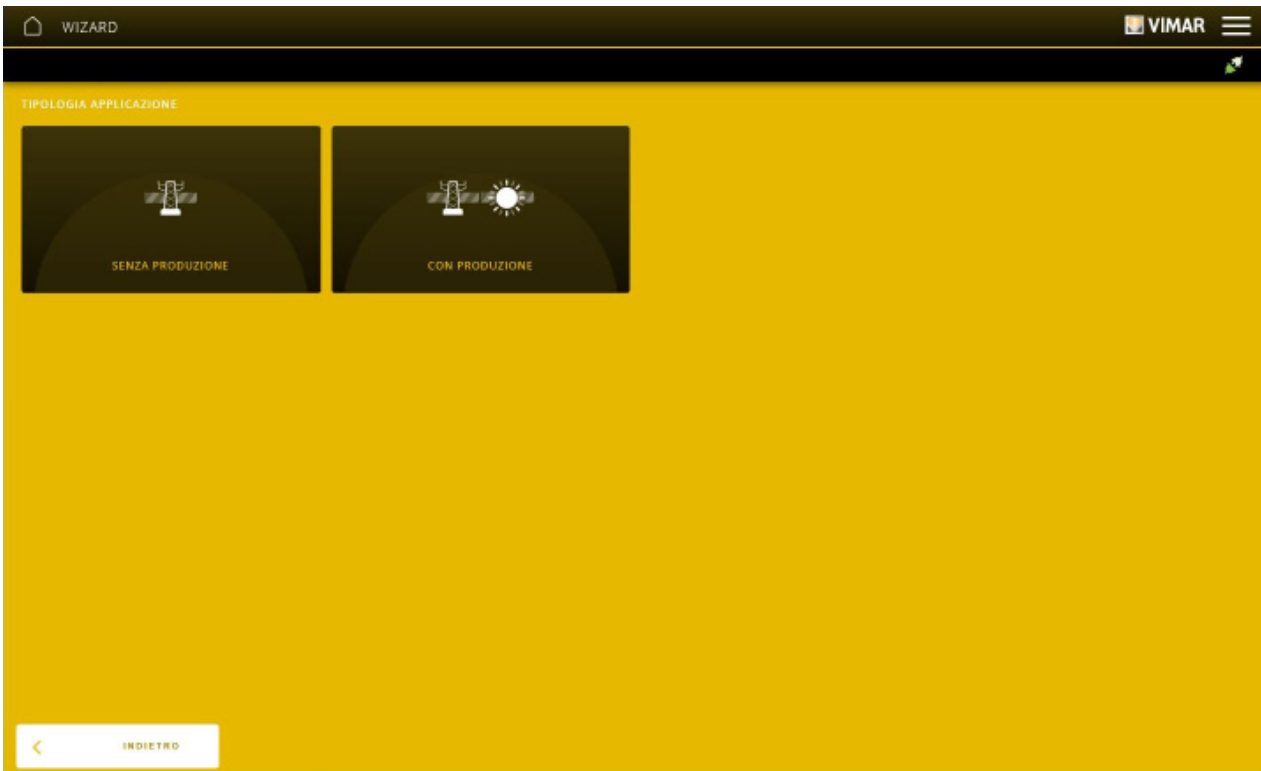

Configuration with View Pro App

In this example, the system selected will be single phase with LOCAL PRODUCTION.

You will then be prompted to select, using the drop-down menu, the load control module device you previously enrolled.

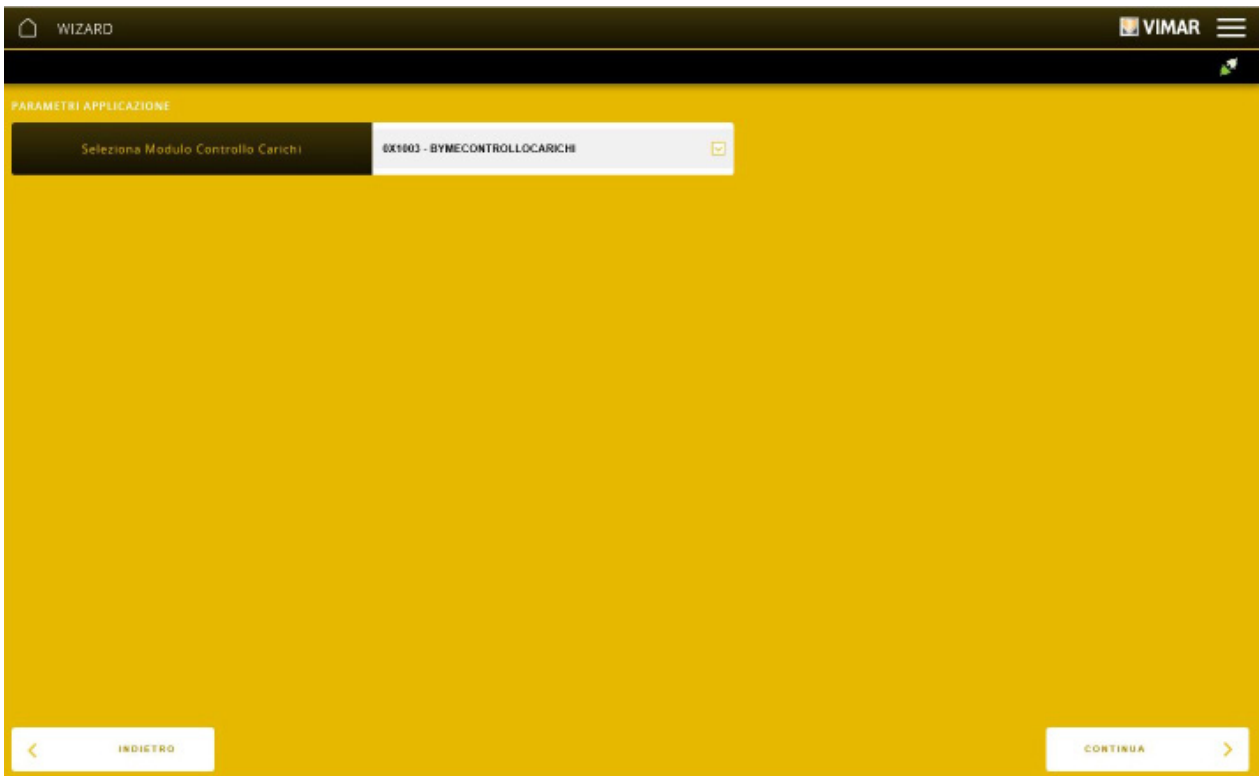

Select "CONTINUE"; you will be prompted to enter the name that identifies the application within the environment.

Click on "END"; the screen displayed is where the functional units of the devices are paired with the application.

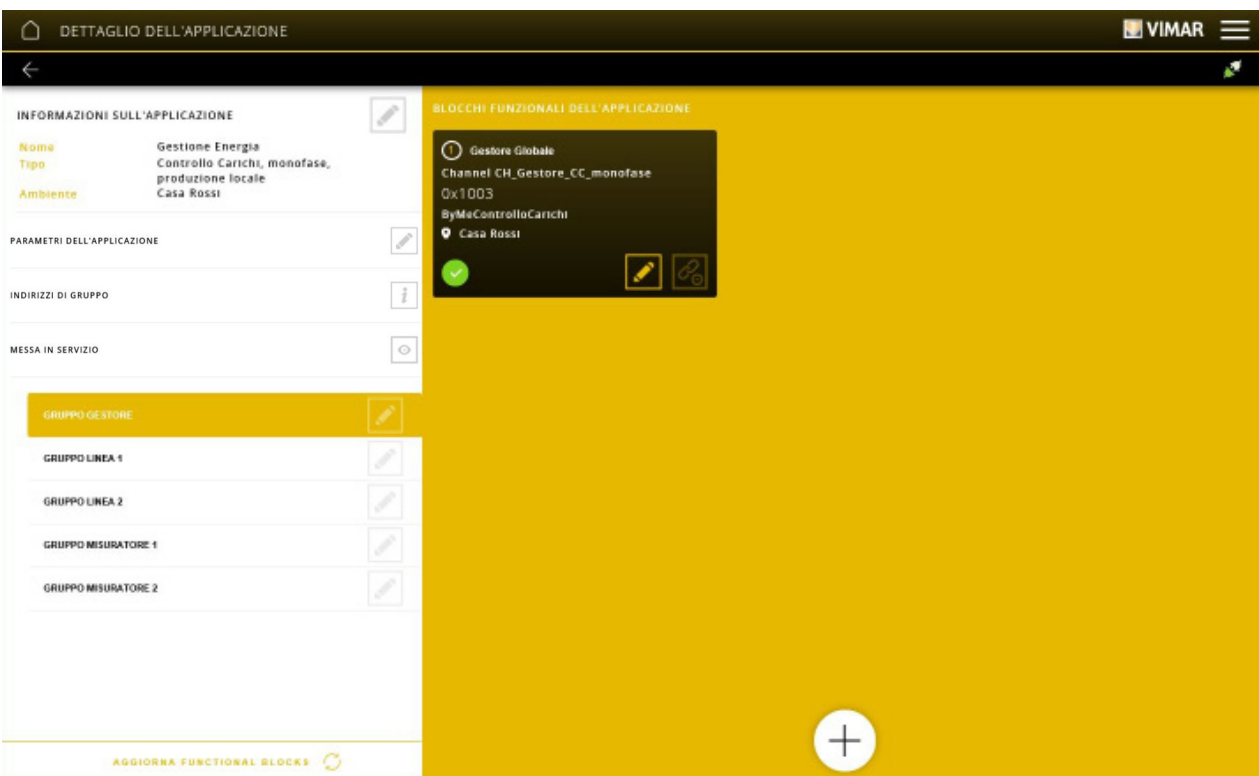

- The COMMISSIONING option is designed to display, by selecting  , the instant power values read by the meters; the function is useful to check the correct operation and positioning of the probes.

Configuration with View Pro App

For instance, in the event of a single-phase system:



If the system is three-phase, three values will be displayed, whereas, for example, in the presence of a three-phase system with production, then six values will be displayed.

In the APPLICATIONS screen, select ENERGY again and click on  ; now configure the relay functional unit of the load to be controlled.

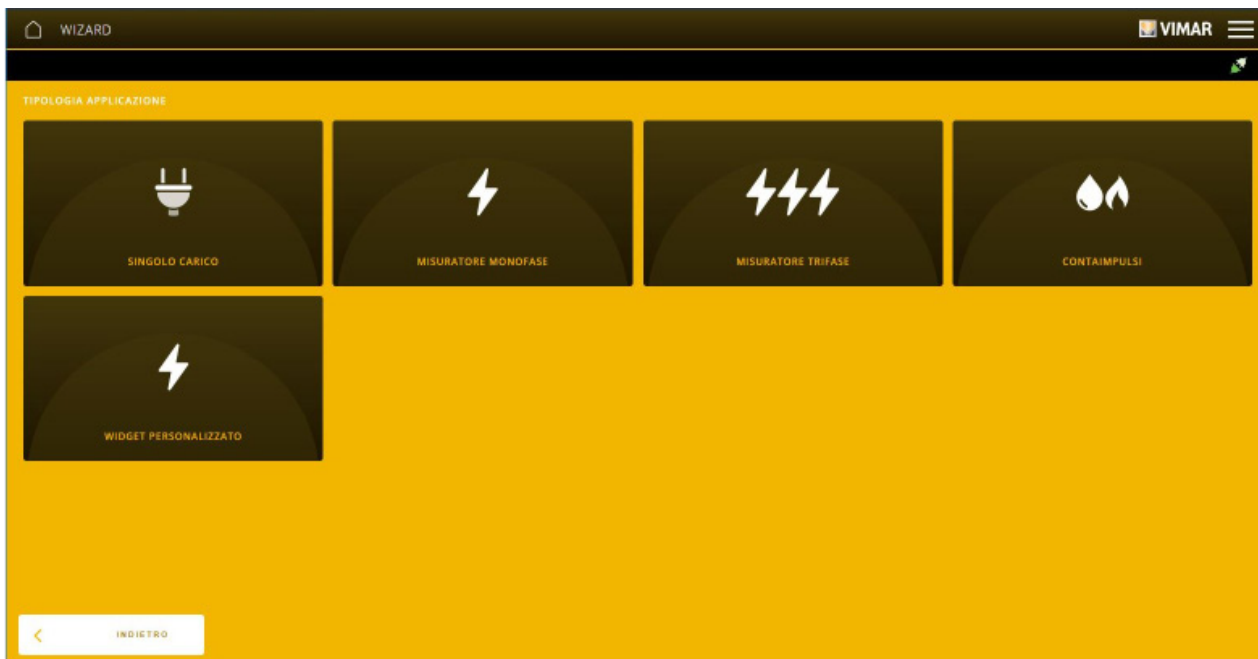

Select SINGLE LOAD; you will then be prompted to select, using the drop-down menu, the function that the relay should carry out.

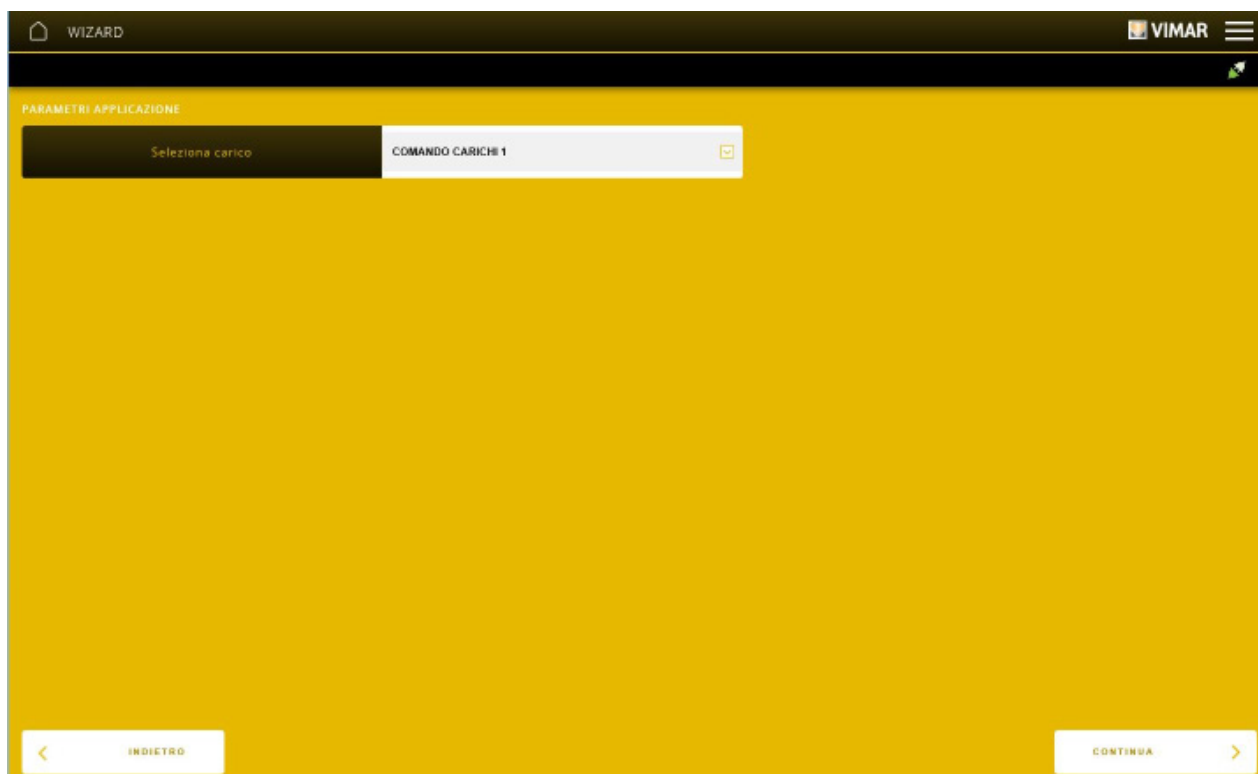

Once the settings have been made, select "CONTINUE"; you will be prompted to enter the name that identifies the application within the environment. **We recommend you assign an unequivocal name that is easy to identify among all the devices in the system (useful to speed up diagnostics tasks, maintenance, etc.).**

Configuration with View Pro App

Click on "END"; the screen displayed is where other functional units can be paired with the application.

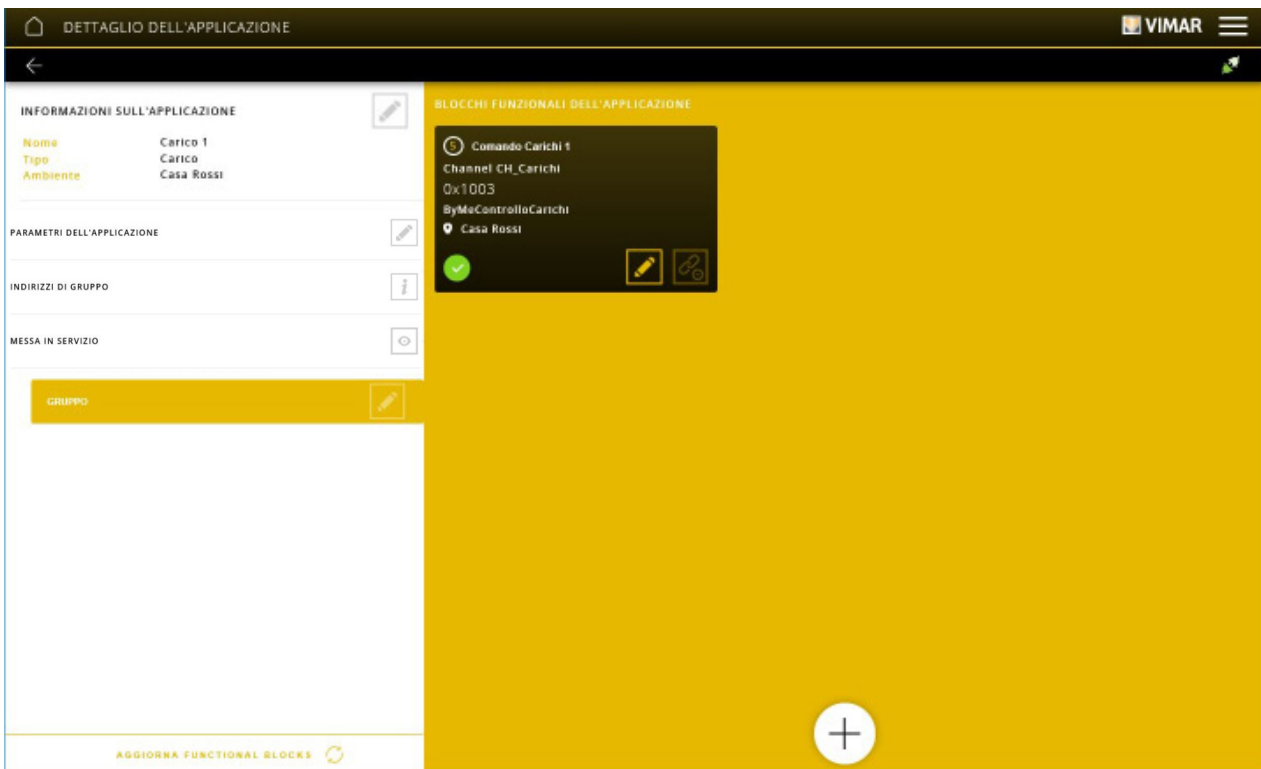

4.3.8 Example of IRRIGATION application creation

Click on to select the environment with which to pair the application, select IRRIGATION and then click on .

The screen displayed allows you to access the menus to define the number of zones and the operating modes to adjust them.

Select MULTI-ZONE SPRINKLING and set the number of zones making up the sprinkler system (for instance 5).

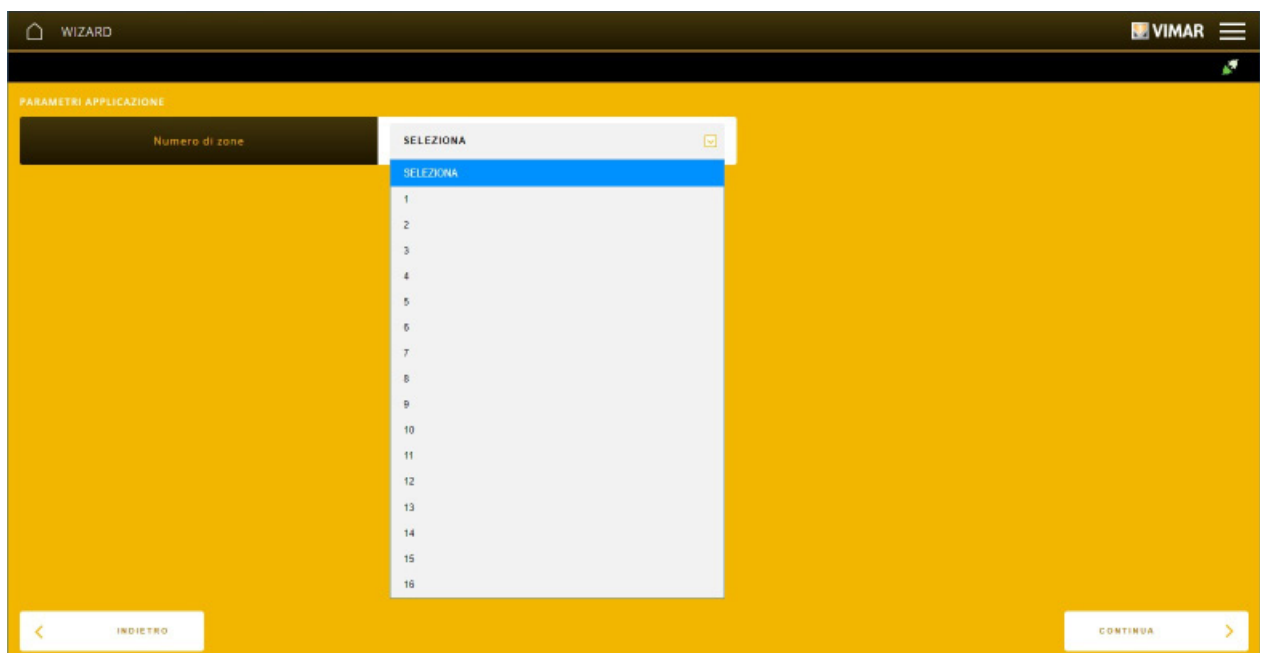

Once the setting has been made, select "CONTINUE"; you will be prompted to enter the name that identifies the application within the environment. . **We recommend you assign an unequivocal name that is easy to identify among all the devices in the system (useful to speed up diagnostics tasks, maintenance, etc.).**

Configuration with View Pro App



Click on "END"; the screen displayed is where other functional units can be paired with the application.

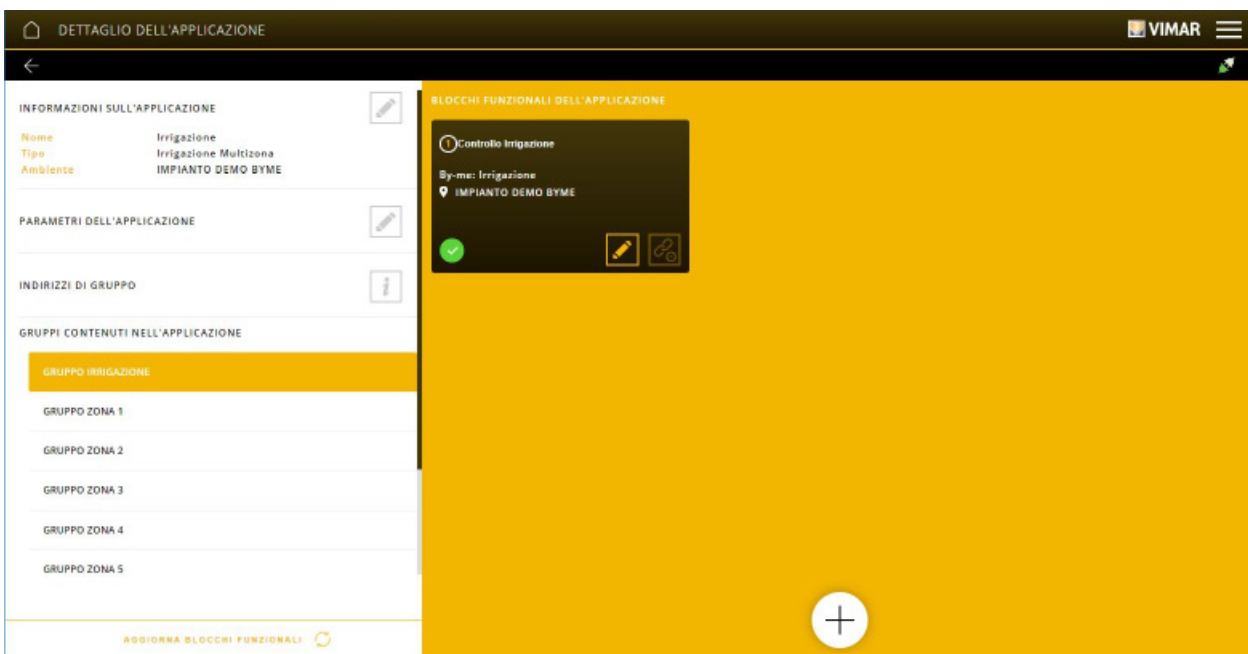

At this stage, within each group, the functional units should be paired as follows:

- in SPRINKLER GROUP pair all the buttons used to manage the sprinkler system (activation, deactivation, change zone, etc.) and/or a contacts interface connected to a rain sensor to block the automatic launch of the sprinkler system programme in the event of rain.
- in ZONE 1 GROUP pair the relays that control the sprinkler system in zone 1, in ZONE 2 GROUP those that control zone 2 and so on. "Circulation pump" type devices can also be configured in these groups (for instance art. 01850.2 or 01470.1); this function can be used for example to activate a pump or valve common to all the outputs.

Every Sprinkler system application created is associated with a single name which is also created in the View Pro App; we recommend you assign a name that clearly identifies the portion of the garden that the associated relays need to irrigate (for instance "Drip hose on South side", "Sprinkler on North side", etc.).

From fw version 1.21.x and later of the home automation system gateway, you can customise the name of each zone associated with the sprinkler system application. To make this setting click on within the ZONE x GROUP, opposite the Sprinkler System Output functional unit. The zones for which no customisation has been made and/or in the presence of obsolete versions of the home automation system gateway will be specified with the generic name "output X (X=1, 2, ..., 16)".

Depending on the need to identify the portions of the sprinkler system, to manage them independently or to set the automatic activation scheduling without overlaps, the application or applications can be configured differently.

We recommend you use a single Sprinkler system application when the system consists of few zones that are always managed unequivocally (all ON, in sequence, no output on pause).

We recommend you use **multiple applications** when the portions of the garden to be irrigated need to be managed differently (in other words specific name of the application and possibility of pausing it independently).

	SINGLE APPLICATION	MULTIPLE APPLICATIONS
Identification	LIMITED Single name for application (for instance "Garden sprinkler system").	COMPLETE Different names for application (for instance drip/sprinkler system) or type of position (for instance Eastern side, South side).
Independent management	NO Single programme with all the zones active in sequence or on pause.	YES Multiple programmes of different applications which, according to need, can be activated in sequence or on pause.
Automatic activation scheduling without overlaps	YES Valid for all outputs of the single application.	NO Valid for the outputs of each single application. In the case of multiple applications, the overlapping of activations should be planned "manually".

Configuration with View Pro App

In short:

- A. To manage the Sprinkler system with a single drip hose or a small garden with a group of different sprinklers, using a single application is sufficient.
- B. For gardens which are large enough to be divided up by type (drip/sprinkler) or area (North side, South side, etc.), using multiple applications is preferable.

Examples.

The examples illustrated below refer to case B (case A is simply a variant of it).

1. Three sprinkler system applications due to the need to differentiate the type (drip/sprinkler) and topology (North/South); two independent drip hoses (for hedges in different positions, North and South) and 1 group of sprinklers (North side).

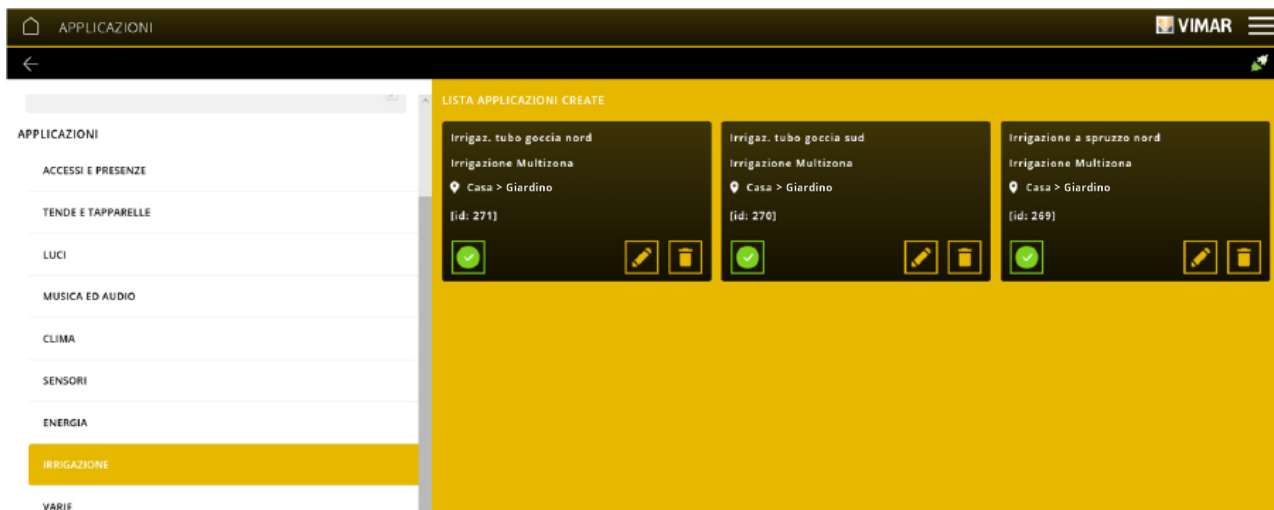

2. Drip hose application (North side, similarly to South side) with a single zone (i.e. a single relay).

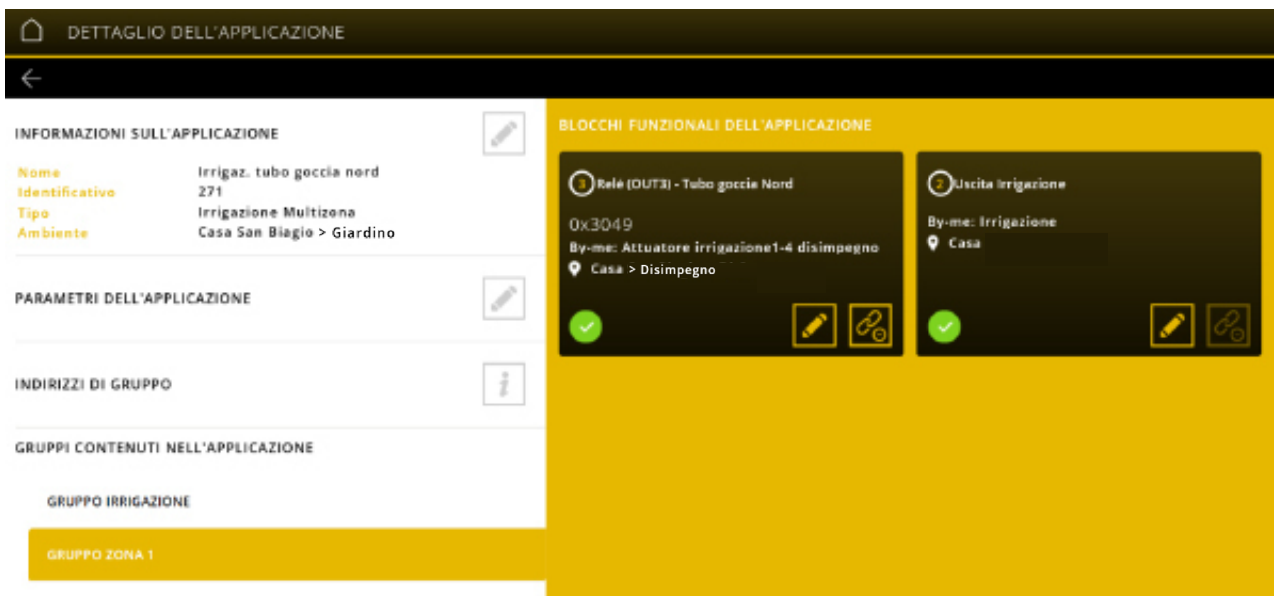

Configuration with View Pro App

3. Sprinkler application (North side) with two zones (i.e. two relays).

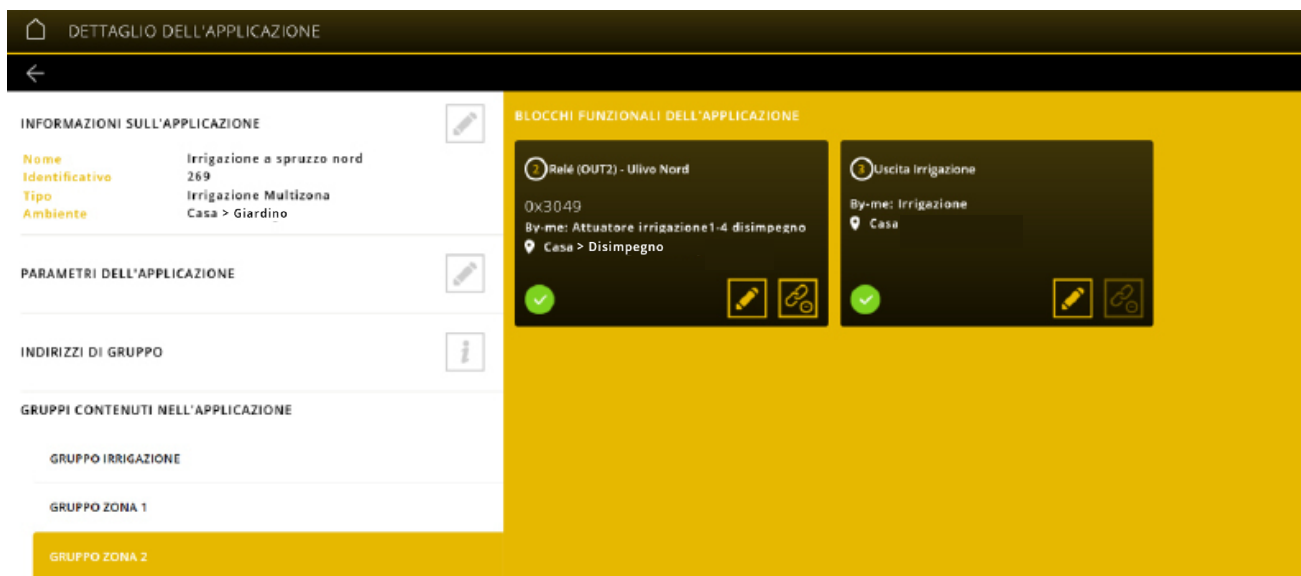
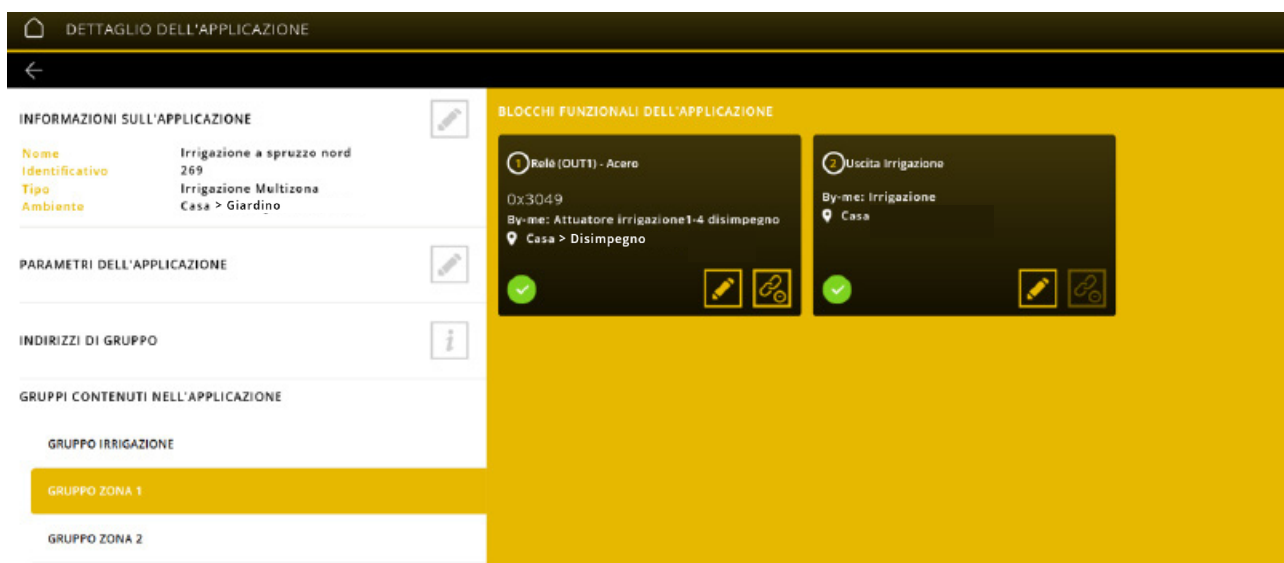

Configuration with View Pro App

4.3.9 Example of VARIOUS application creation

Click on  to select the environment with which to associate the application, select VARIOUS and then click on .

The screen displayed allows you to define the functions linked to automations, control and displays.

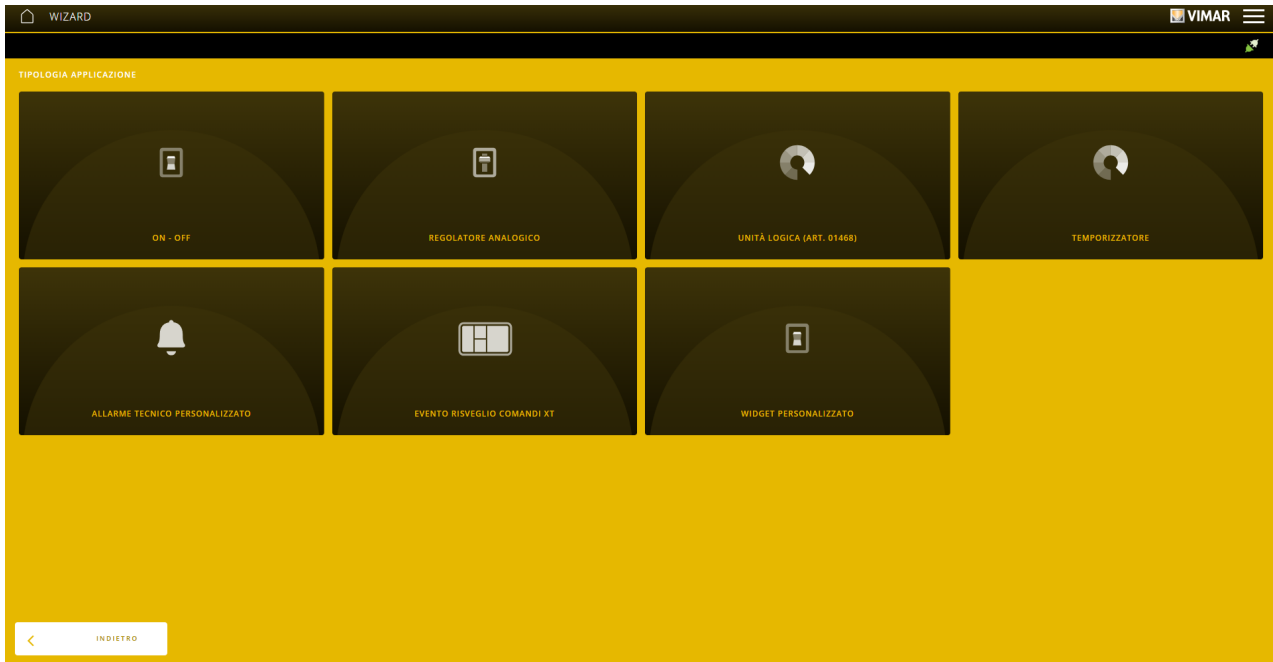

- The ON-OFF option creates an application that performs on/off functions, controlling a relay in the system. In this type of application, you can also configure “circulation pump” type devices (for instance art. 01850.2 or 01470.1) possibly already used in the outputs of applications in the CLIMATE CONTROL domain; this function is useful for integrated with temperature control logics, for example
- The ANALOGUE DIMMER option allows you to pair an analogue output in voltage or current (for instance of the actuator with 4 analogue outputs 01466.1) to control different types of automations from a By-me Plus button.
- The LOGIC UNIT option allows the configuration of logic unit 01468 which can be used to manage additional logical programmes.
- The TIMER option provides default programmes (weekly, periodical, astronomical) which send an ON control to a group of relays or to a scenario according to settable time intervals.
- The “CUSTOMISED TECHNICAL ALARM” option creates an application that can only be used in the Editor of logic programmes and that makes it possible to send a notification message following an activation/deactivation. The message text is written directly by the installer so its translation into various languages is not envisaged.
- The XT CONTROLS WAKE-UP EVENT option allows the creation of a specific application for devices of the XT platform; see paragraph 4.4.6 for further details
- CUSTOMISED WIDGET creates an application with virtual datapoints to interact with a KNX system; this application generates a dedicated screen on the touch screens for the management of the virtual datapoints in order to control the KNX system.

Configuration with View Pro App

4.3.10 Example of SCENARIOS application

Click on  to select the environment with which to associate the application, select SCENARIO and then click on .

The screen displayed allows you to define the type of control that triggers the scenario.

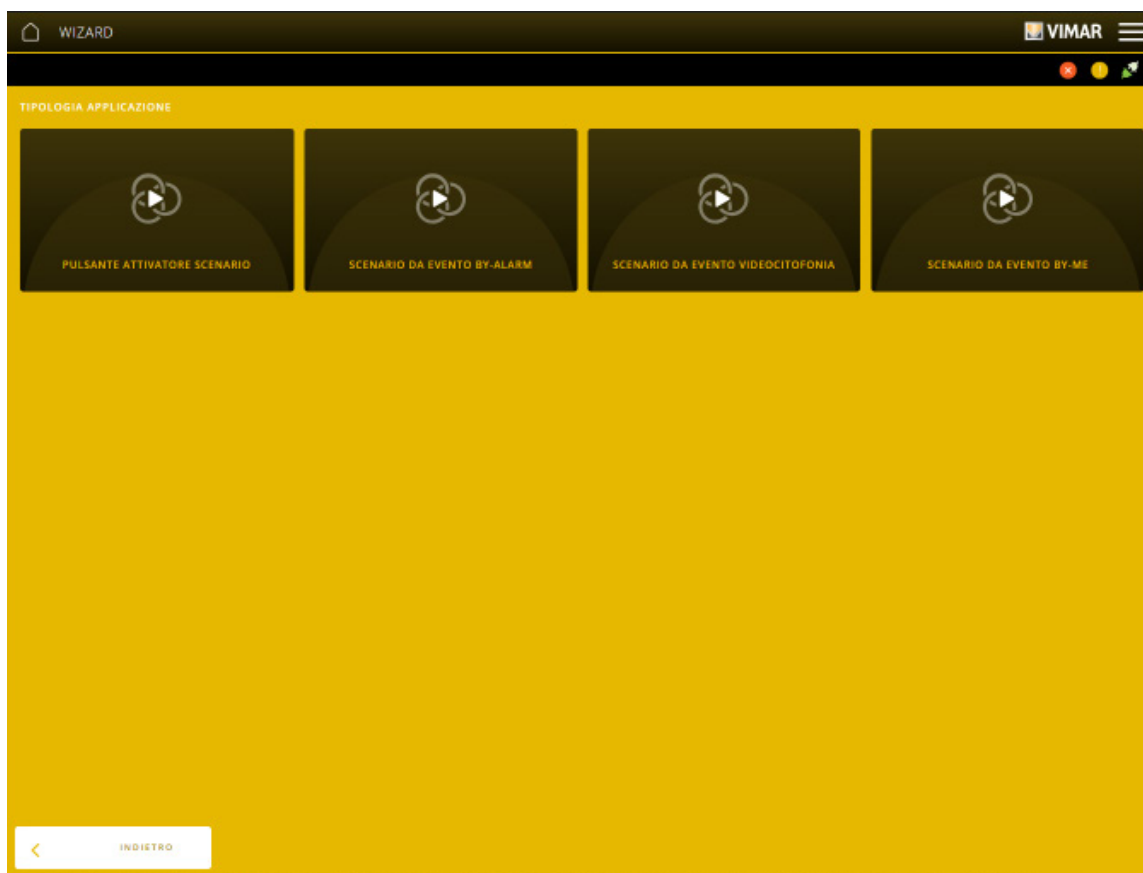

- The SCENARIO ACTIVATOR PUSH BUTTON option allows you to pair a By-me Plus button with a scenario that the user will create using the View App; the button will then be set up during the configuration phase and subsequently paired with the scenario created. The scenario will then be activated by pressing the button.
- The SCENARIO FROM BY-ALARM EVENT option, which is only present if a By-alarm burglar alarm system gateway (art. 01712.1) is in the system or if no burglar alarm system gateway has been configured, allows you to pair an event in the burglar alarm system (on, off, alarm, etc.) with the scenario created by the user so that the same is activated when the said event occurs.
- The SCENARIO FROM BY-ALARM PLUS EVENT option, which is only present if a By-alarm Plus burglar alarm system gateway (art. 03812) is in the system, allows you to pair an event in the burglar alarm system (on, off, alarm, etc.) with the scenario created by the user so that the same is activated when the said event occurs.
- The SCENARIO FROM VIDEO DOOR ENTRY SYSTEM EVENT option allows you to pair an event in the video door entry system (call receipt - start/end) with the scenario created by the user so that the same is activated when the said event occurs.
- The SCENARIO FROM BY-ME EVENT option allows you to associate an event generated by the home automation devices with the scenario created by the user so that the same is activated when the said event occurs. This option contains the possibility of defining a SCENARIO FROM AIR QUALITY EVENT.

IMPORTANT: From chapter 5 onwards is a description of the devices with which the various applications are carried out, all their functional units, the settable parameters and their meaning.

Configuration with View Pro App

4.4 Special applications

This paragraph illustrates (with some examples) the applications requiring additional steps which need to be pointed out.

4.4.1 Example of application creation for control via IR module and remote control.

Click on to select the environment with which to pair the application, select AUDIO or CLIMATE CONTROL (the IR module may in fact be used to control a stereo system or an air conditioning device) and then click on .

The IR module (previously enrolled) is made up of three functional units; select the desired one and enter it in the application (in this example " IR interface").

Return to the HOME page and select DEVICES -> BY-ME DEVICES; on the IR module, click on to display the detailed screen (which also contains the functional unit inserted in the application).

To proceed, you first need to have enrolled the "IR module" device VIA BUS. If the IR module has been enrolled VIA CATALOGUE you will be unable to proceed.

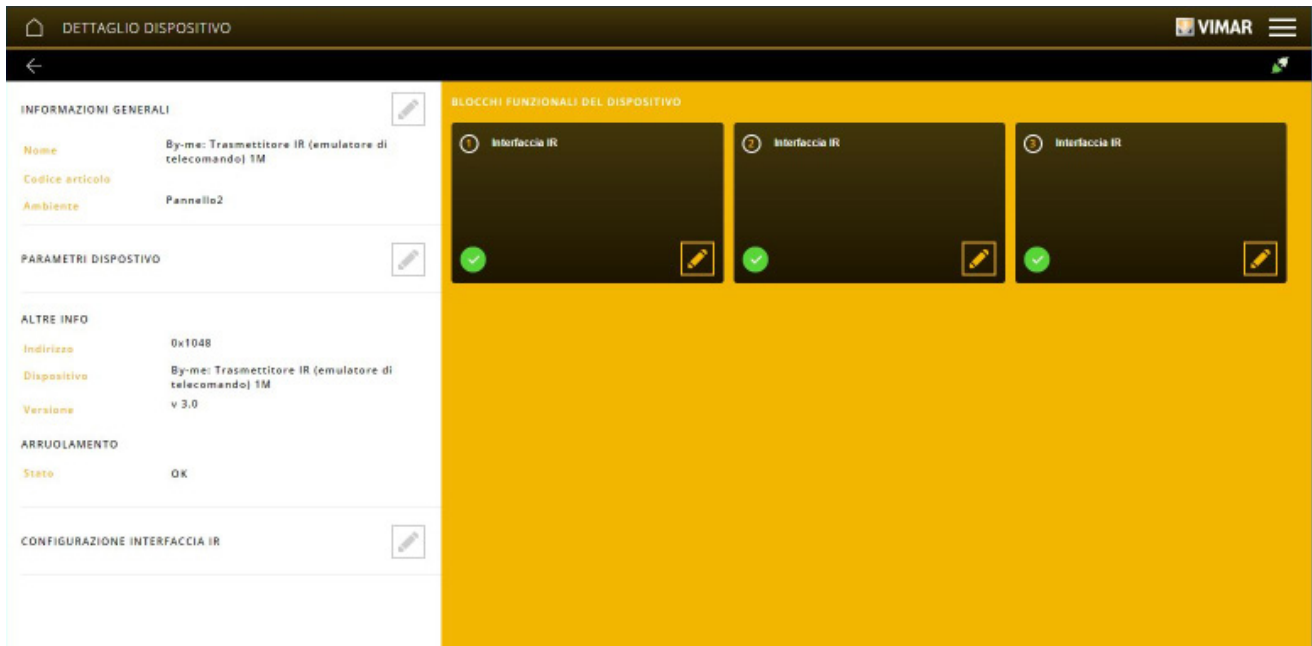

Select at "IR INTERFACE CONFIGURATION"; the screen displayed allows you to pair the remote control buttons with the respective actions.

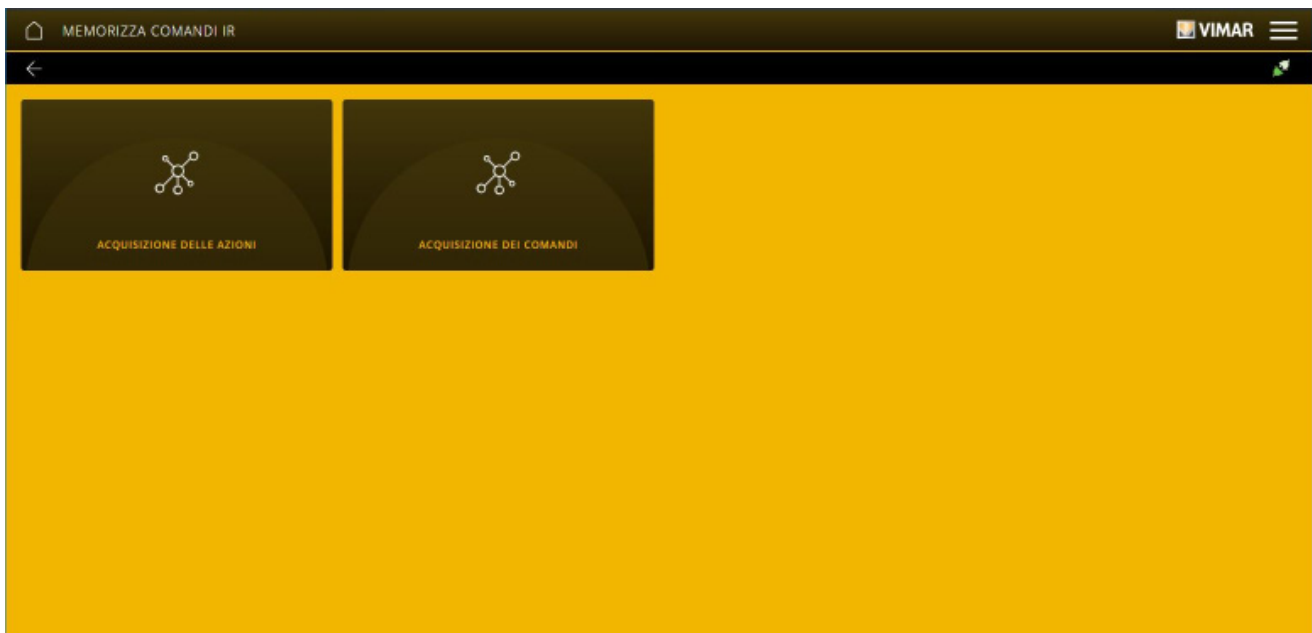

Configuration with View Pro App

Select ACTION ACQUISITION.

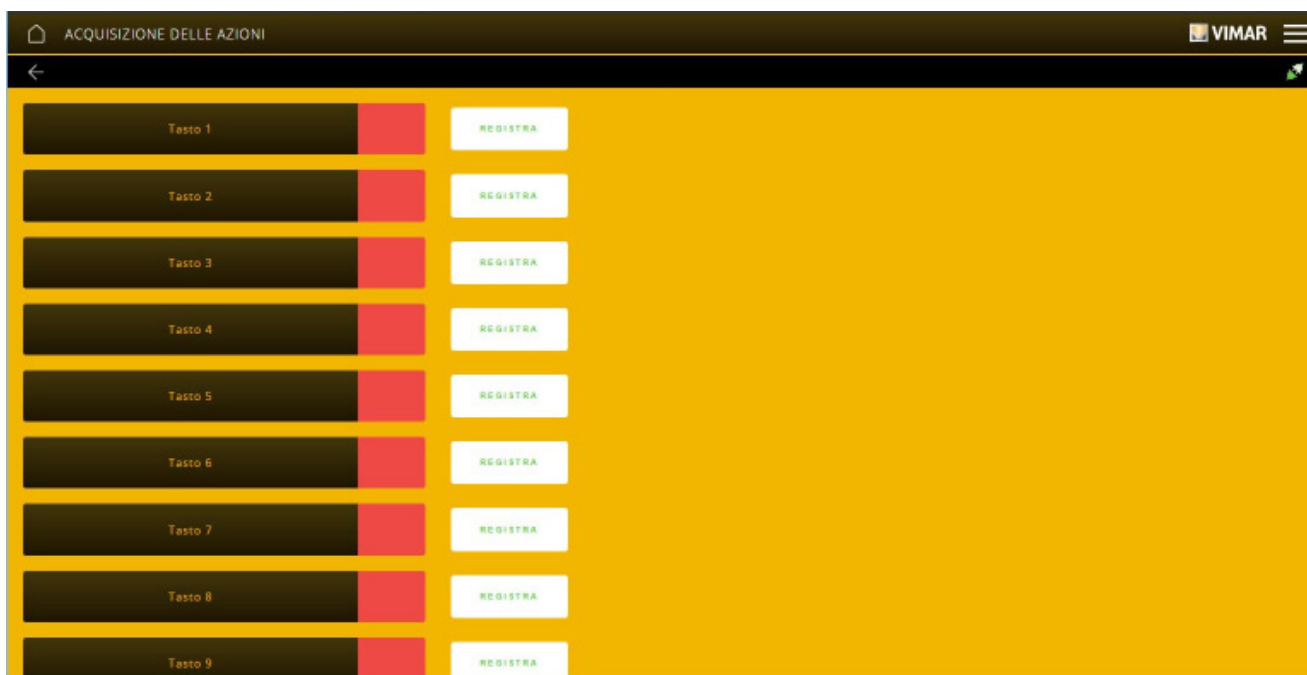

For Button 1 select "REGISTER".



Press the configuration push button of the IR module and then button 1 on the remote control; once the button has been configured, the colour changes from red to green.

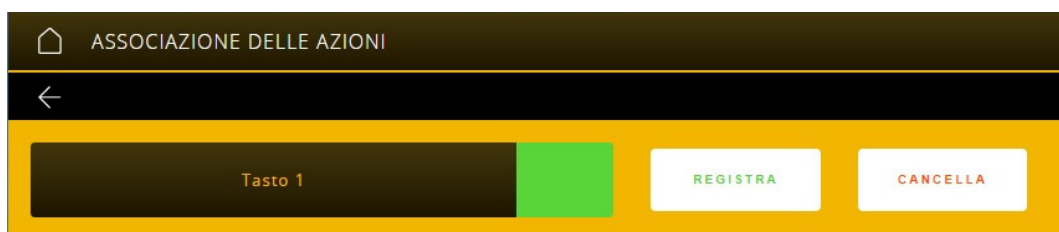



Repeat the procedure for all the remote control buttons to be saved.

- The "DELETE" option deletes the button registration so that it can be saved again.

Configuration with View Pro App

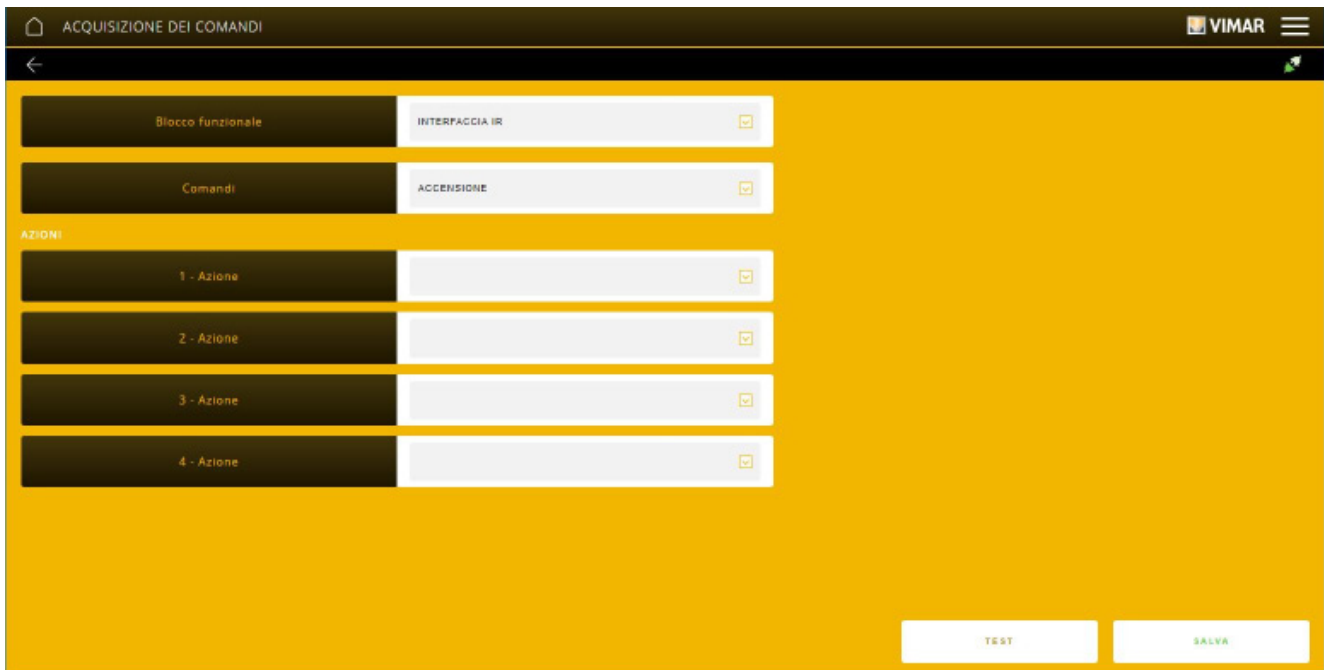
Now select ACQUISITION OF CONTROLS.





Use  to select:

- the functional unit of the IR module to use on FUNCTIONAL UNIT (if several units have been configured);
- the type of control to carry out on CONTROLS (these vary according to the type of AUDIO or CLIMATE CONTROL application);
- on ACTIONS, those to be acquired. The IR Module is capable of saving the button of an infrared remote control and of replicating its operation following a By-me Plus control.

Once this procedure is complete, simply insert the functional units of the devices you wish to control via the IR module and remote control in the application.

4.4.2 Example of application creation with HVAC controller.

Click on  to select the environment with which to pair the application, select CLIMATE CONTROL and then click on .

Select HVAC CONTROLLER; the screen displayed is for the selection of the type of valve.

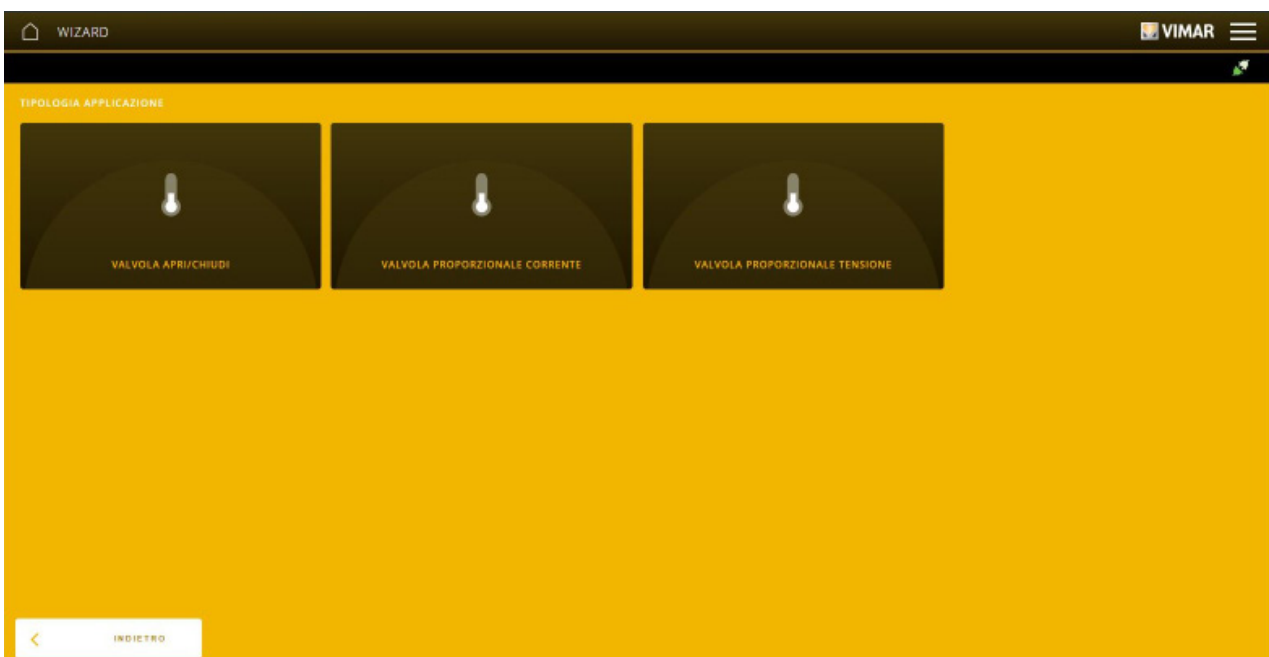

In this example, OPEN/CLOSE VALVE is being selected.

Configuration with View Pro App

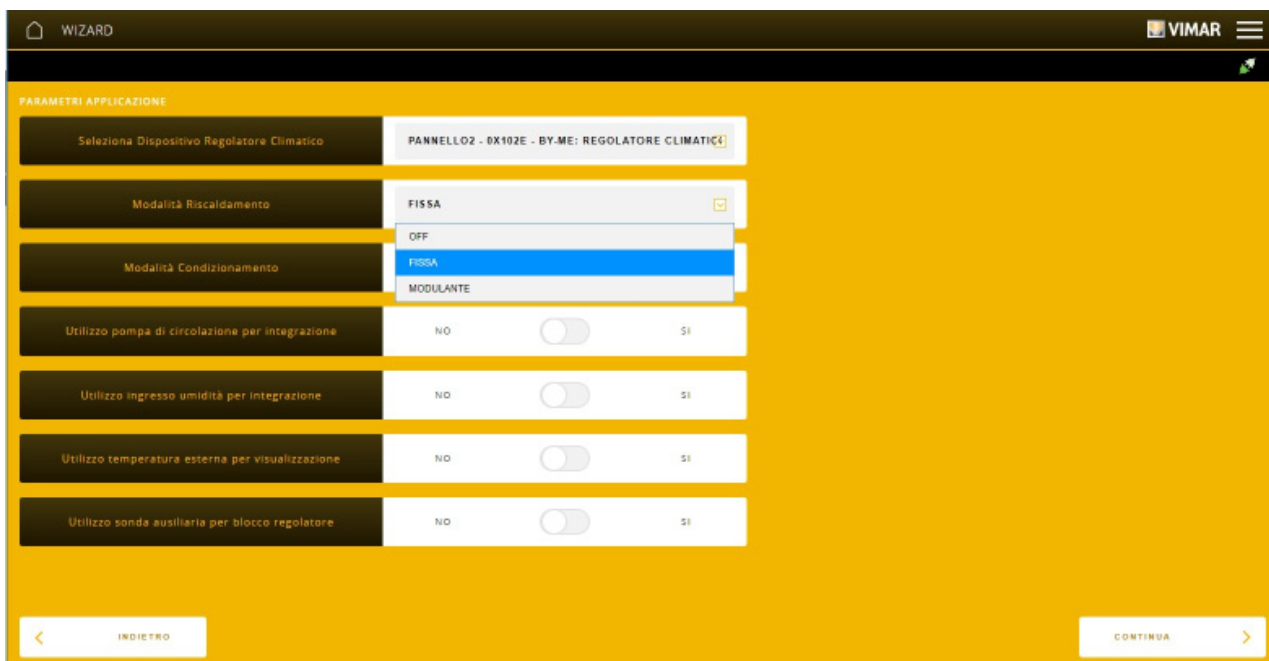

Make the settings relating to Heating and Air Conditioning mode by clicking on (for instance both fixed) and choose which uses to activate (for instance all deactivated).

Select "CONTINUE"; you will be prompted to enter the name that identifies the application within the environment.

Click on "END"; the screen displayed shows the application with the HVAC controller in operation.

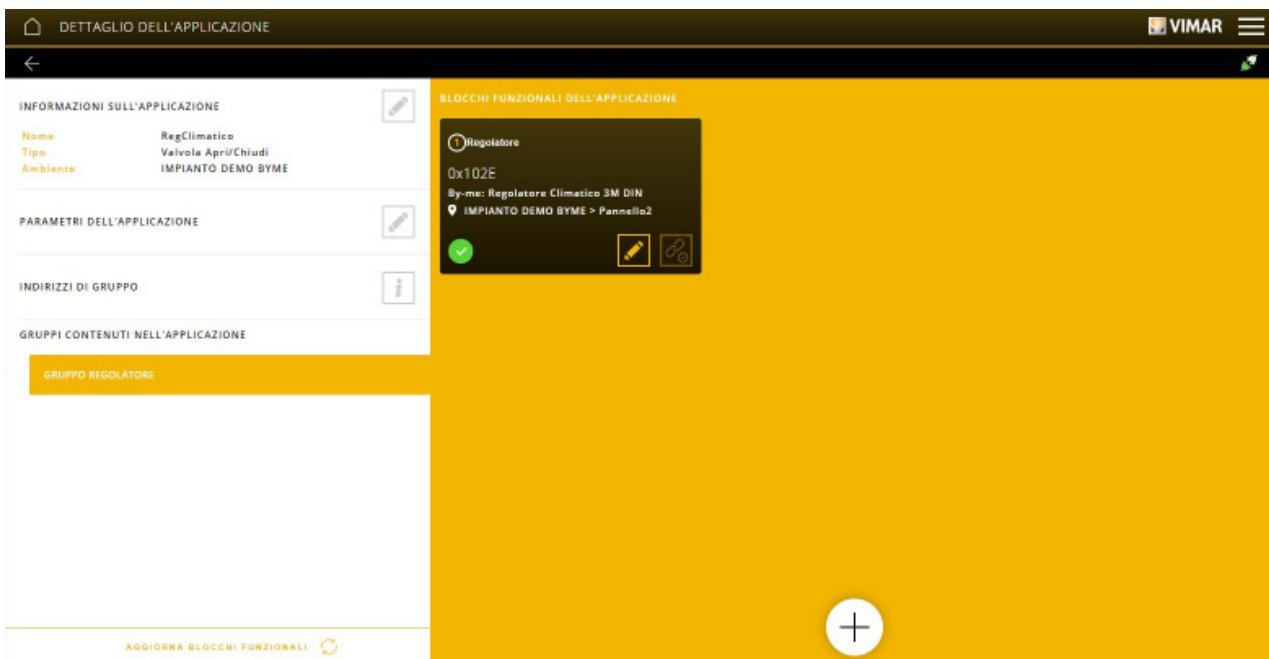

If you choose to activate one or more uses, in addition to the DIMMER group, the functional units relating to the probe inputs and the groups relating to the activated use will be present.



Configuration with View Pro App

- By enabling “Use of circulation pump for integration”, within the HVAC controller application, CIRCULATION PUMP GROUP will appear, along with the related functional unit; this will render the dedicated unit to operate the circulation pump visible in the logics editor.

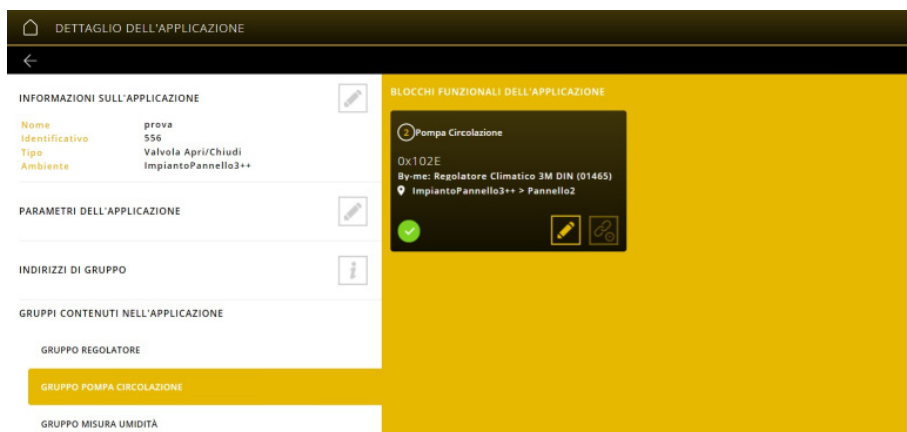

Note: The circulation pump functional unit can also be configured in other climate control applications.

- By enabling “Use humidity input for integration”, within the HVAC controller application, HUMIDITY MEASUREMENT GROUP will appear, along with the related functional unit; this will render the dedicated unit to transmit the humidity value in the logics editor.

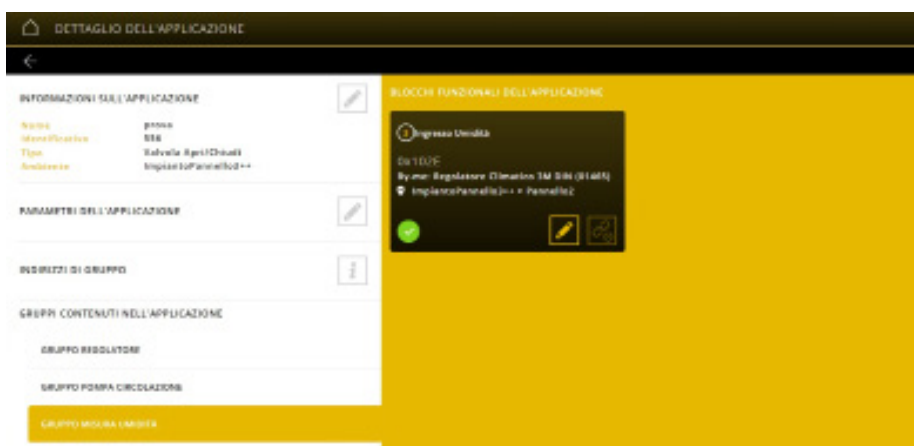

Note: Here, the humidity value will only be managed via logics.

- By enabling “Use of external temperature for viewing”, within the HVAC controller application, the “External Temperature Input” functional unit will be configured in the DIMMER GROUP. This way, the external temperature will be visible in the View App in the HVAC controller screen and it will therefore not need to be configured in a SENSORS application.
- By enabling “Use of auxiliary probe for dimmer block”, within the HVAC controller application, the “Auxiliary Temperature Input” functional unit will be configured in the DIMMER GROUP. This way, when a button is connected to the terminals of the external probe, the button will work like a dimmer block.

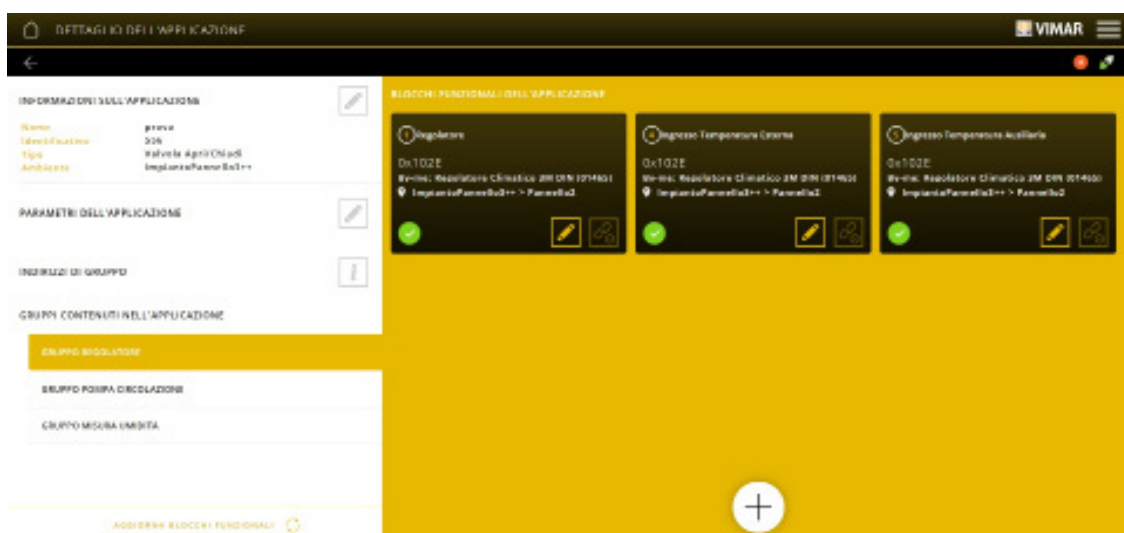

Configuration with View Pro App

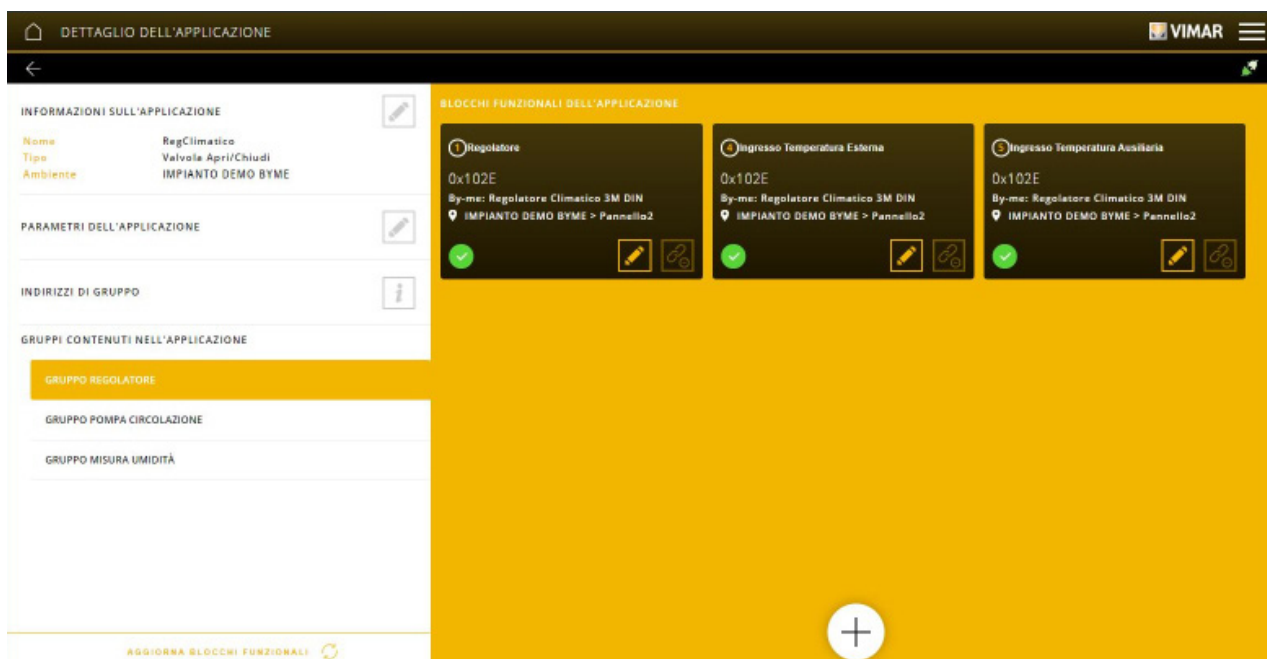

For instance, if you select YES for all the uses, the screen displayed will be as follows:



The HVAC controller will therefore be in operation and can be used according to the settings described in chap. 9.3.

Note. In the applications where the HVAC controller 01465 is present, the button functional units to perform the manual stopping of the device can be inserted.

4.4.3 Example of application creation with thermostat probe.

Click on  to select the environment with which to pair the application, select CLIMATE CONTROL and then click on .

Select SENSOR; the screen displayed is for the selection of the type of probe operation.

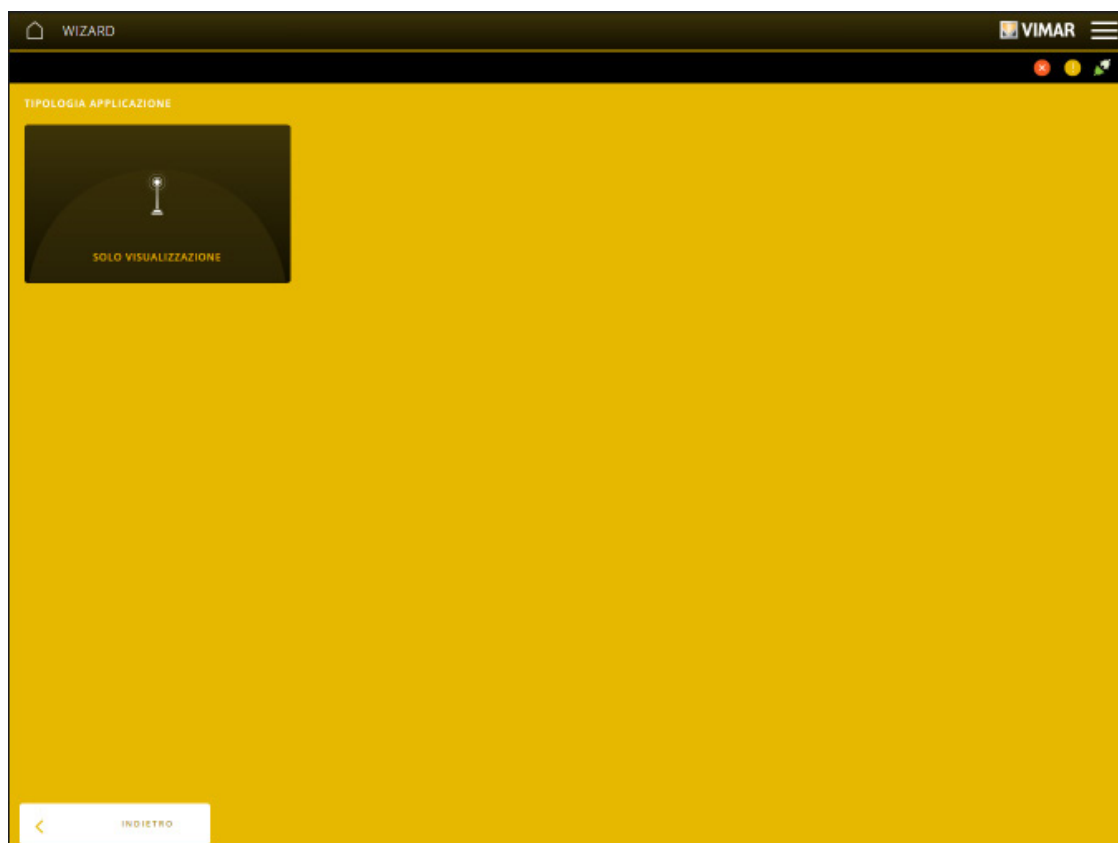

Select DISPLAY ONLY.

Configuration with View Pro App

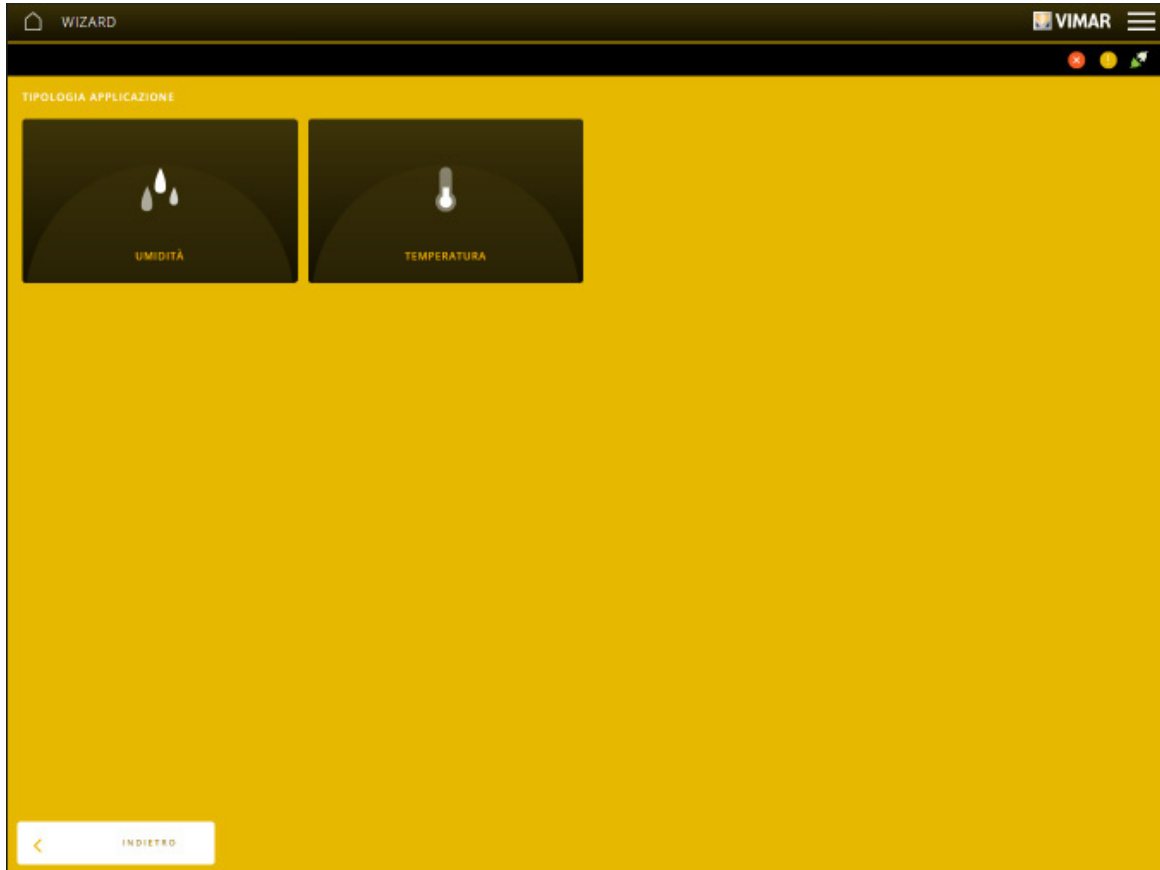

Select TEMPERATURE; the screen displayed allows you to select the probe paired with the thermostat.

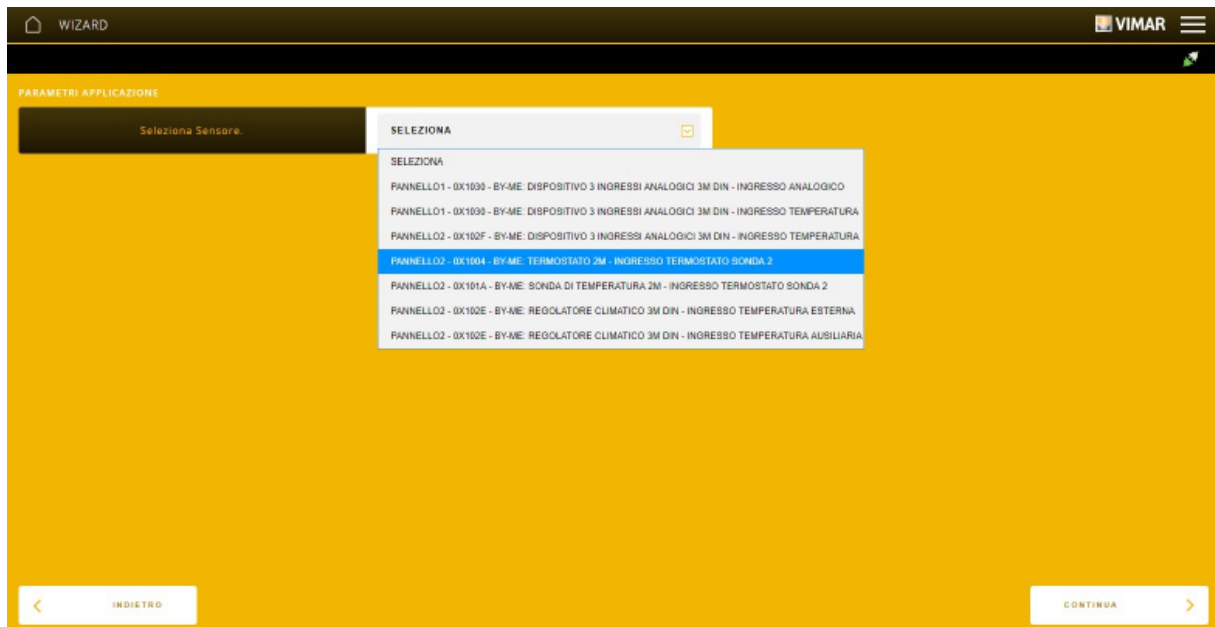

Select "CONTINUE"; you will be prompted to enter the name that identifies the application within the environment.



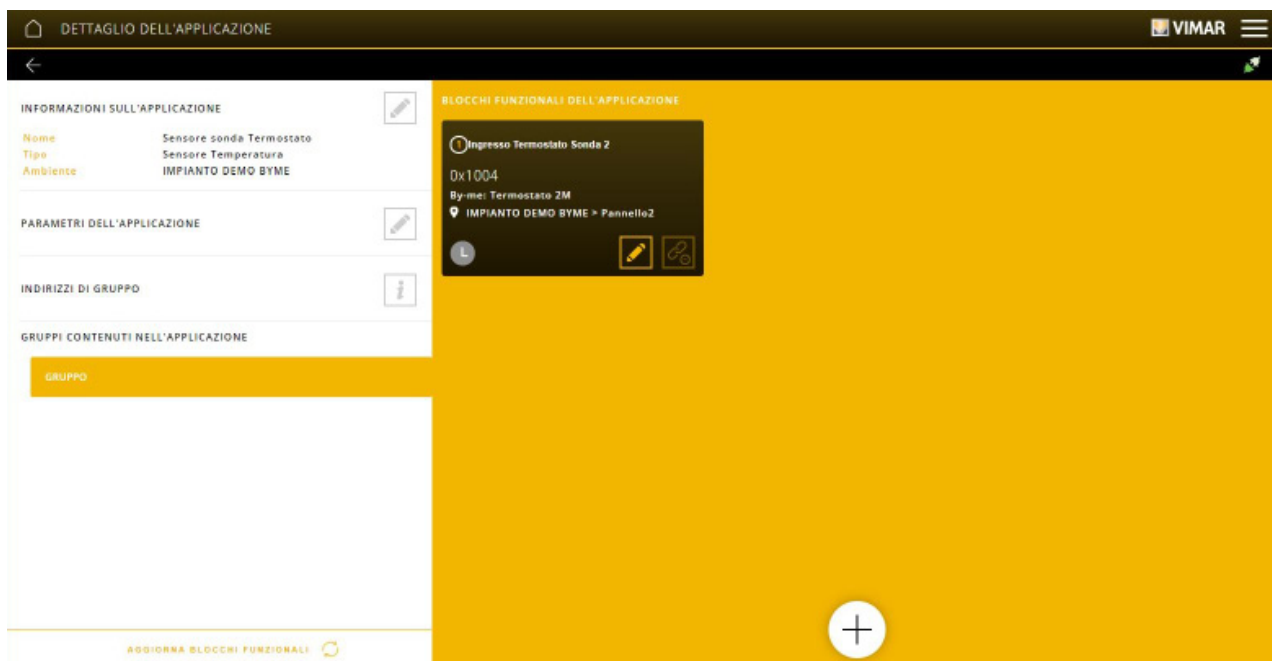

Configuration with View Pro App

Click on "END"; the screen displayed represents the application to view the temperature measured by the thermostat probe.



4.4.4 Example of CLIMATE CONTROL application creation with KNX devices.

Click on  to select the environment with which to pair the application, select CLIMATE CONTROL and then click on .

Select KNX INTEGRATION; the screen displayed is to select the KNX devices supported by the By-me Plus system.

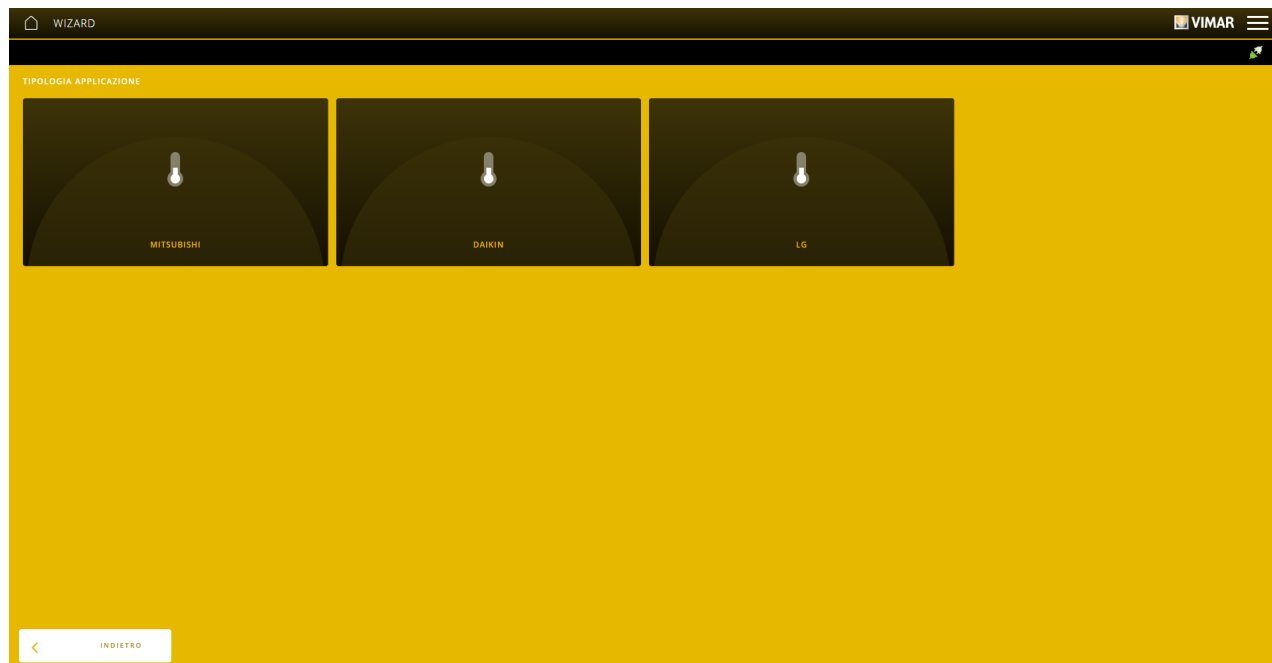

DAIKIN has been selected in this example but the procedure is the same for all other cases.

The screen displayed is for the selection of the DAIKIN device (previously enrolled with the procedure described in para. 4.2.2).

Configuration with View Pro App

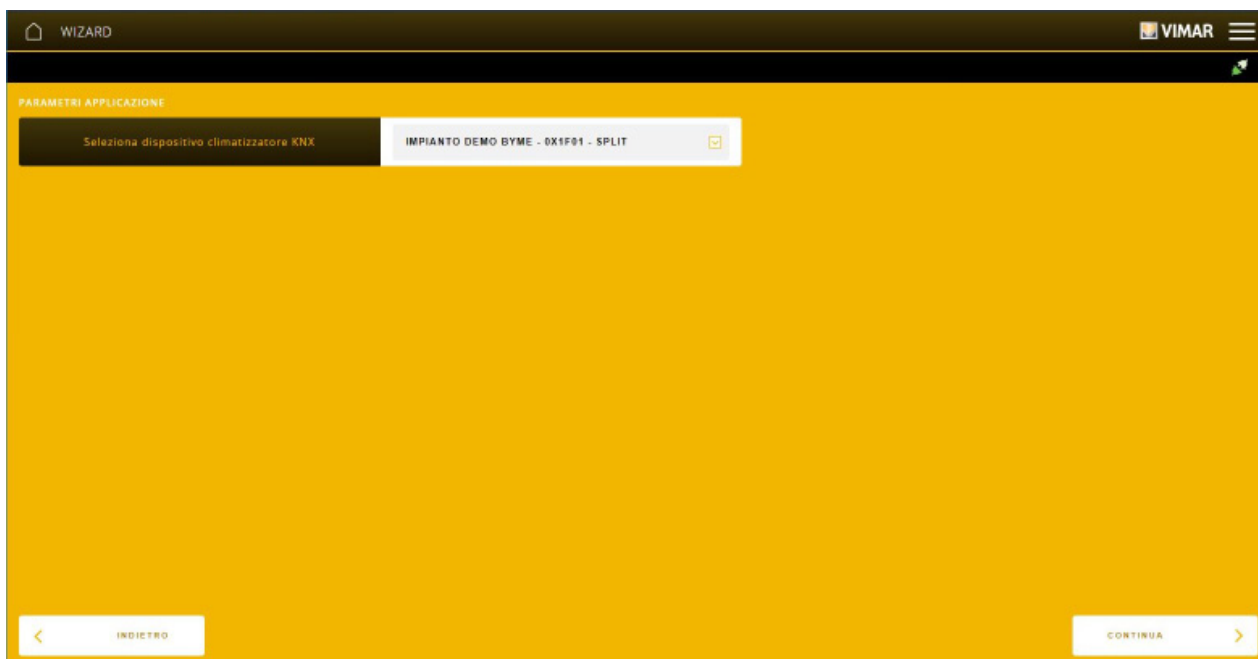

Select "CONTINUE"; you will be prompted to enter the name that identifies the application within the environment.

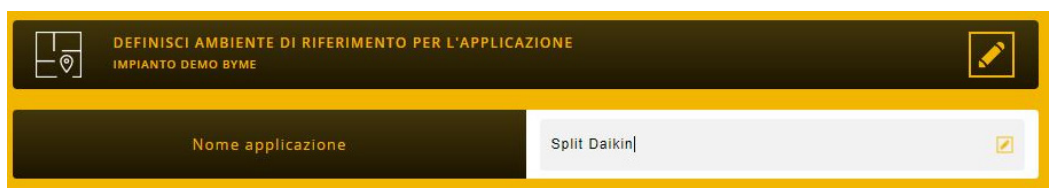

Click on "END"; the screen displayed shows the application dedicated to the management of the DAIKIN device.

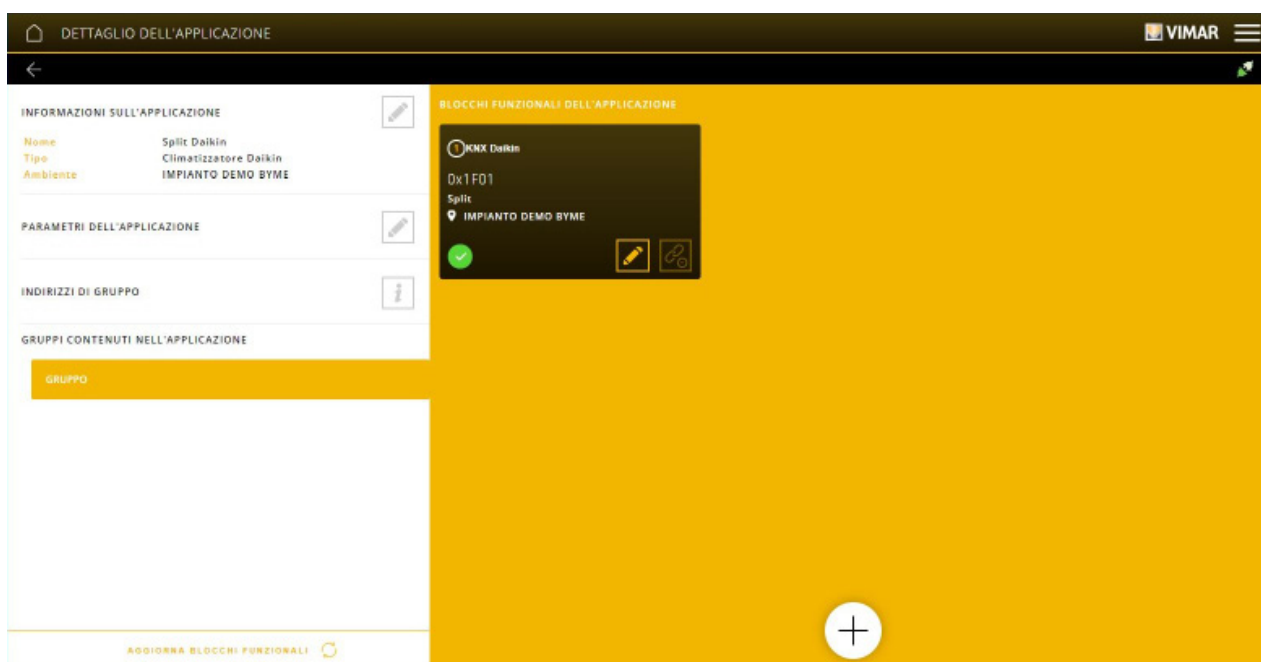

Select  for GROUP ADDRESSES, the addresses of the KNX group that need to be used in ETS to interface the DAIKIN device are displayed.

Configuration with View Pro App

4.4.5 Example of CUSTOMISED WIDGET creation

In this example, a widget relating to the CLIMATE CONTROL application is being created, but the procedure is similar for all types of application.

Click on to select the environment with which to pair the application, select CLIMATE CONTROL and then click on .

Select CUSTOMISED WIDGET; the screen displayed is for the selection of the datapoint to be paired with the respective WIDGET 1, WIDGET 2 groups, etc.

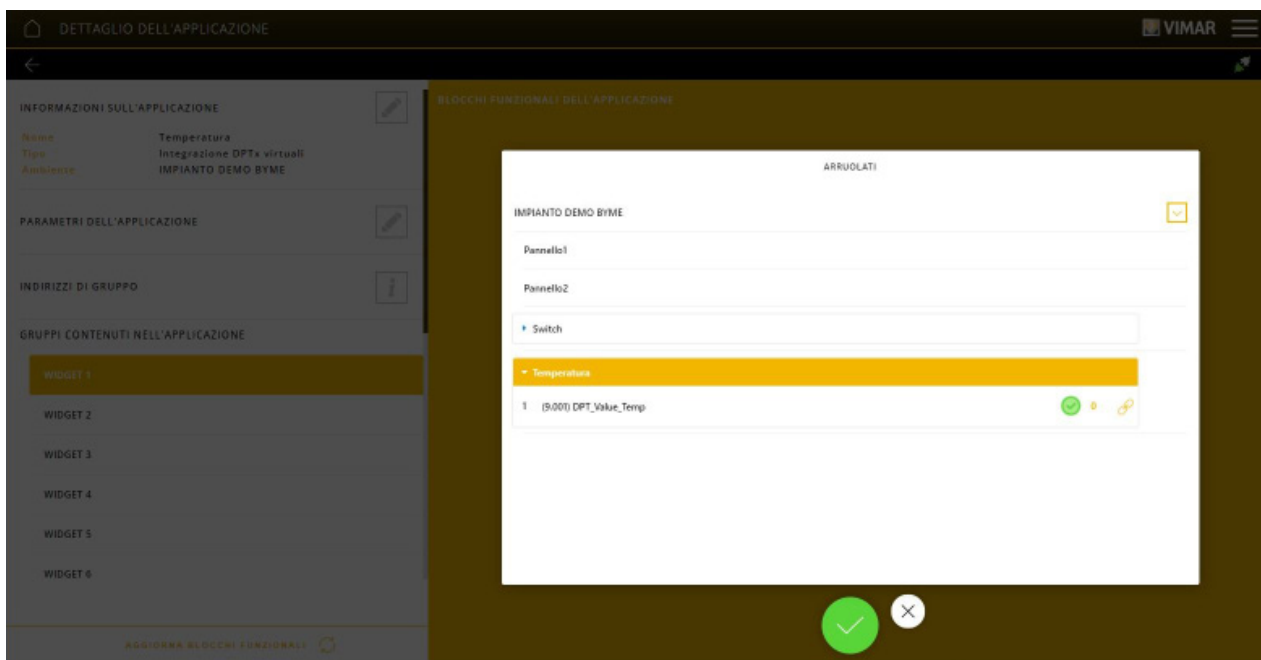

Select the desired Widget from the list of those offered (in this case **(9.001) DPT_Value_Temp**) and confirm with .

The screen displayed shows the application with the Widget you just created.

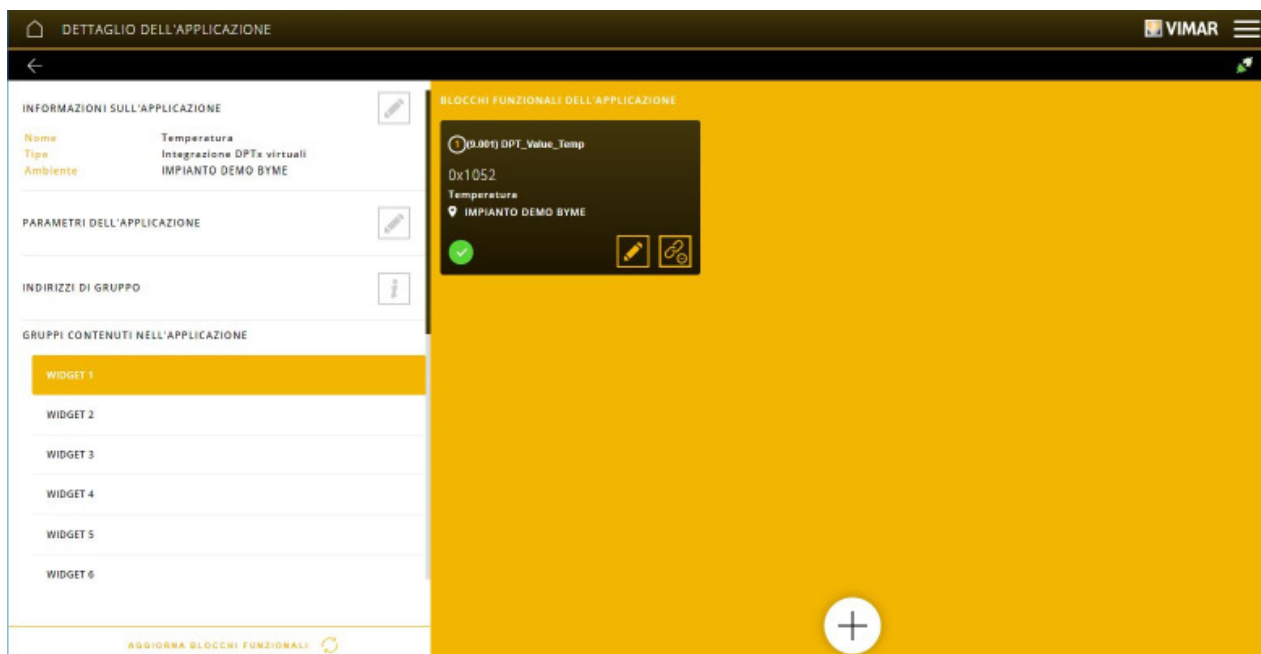

Configuration with View Pro App

4.4.6 Example of application creation for XT controls activation from standby

This application is used to activate (wake-up) XT devices via an external event, in a similar way to when the hand approaches the mounting frame.

Click on  to select the environment with which to associate the application, select VARIOUS and then click on .

Select "XT LINE BUTTONS WAKE-UP EVENT".

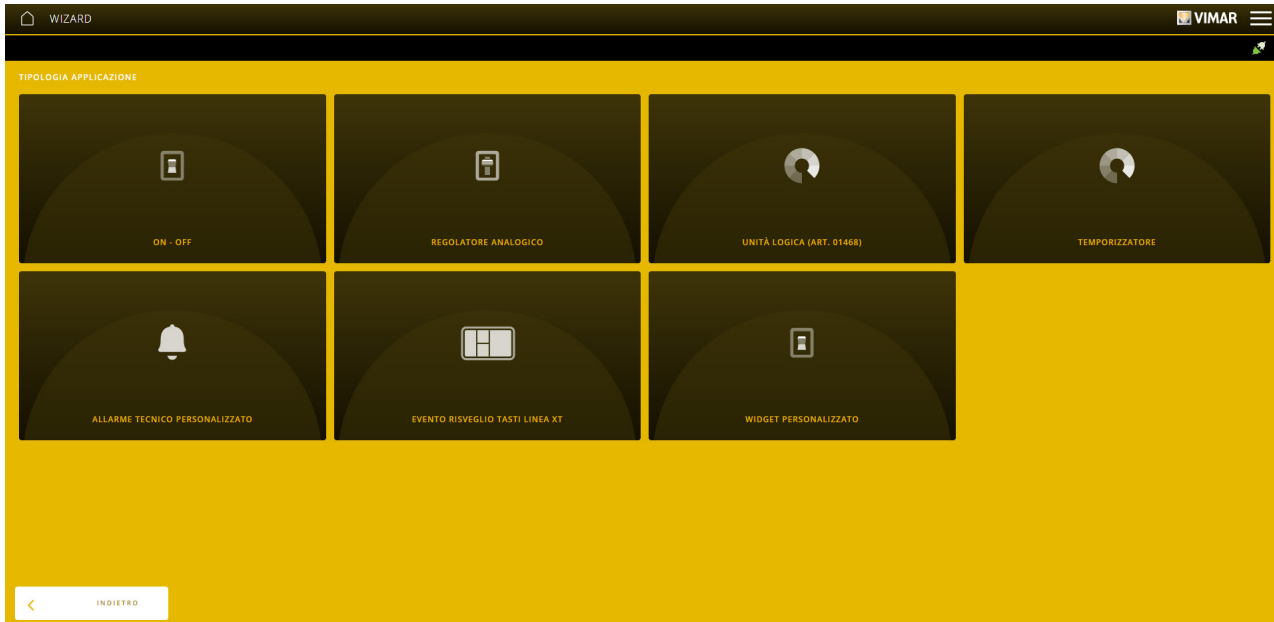

You will be prompted to enter the name that identifies the application within the environment.



Click on "END"; the screen displayed represents the application to manage the XT controls activation event.

This application will initially be empty and can be completed by adding:

- One or more "receiver" type functional units. Each XT platform device (with the exception of actuator 32002) is fitted with this type of functional unit; this functional unit makes it possible to receive the wake-up event and turn on the entire receiving device.
- One or more "writer" type functional units. This functional unit generates the wake-up event; this function can be performed from any device already used as "CONTACT – SENSOR" or as open window signalling (also including the sensors of the By-alarm Plus system). In the absence of this type of functional unit, the functional can always be performed using KNX integrations and/or logic programmes.

Configuration with View Pro App

4.4.7 Example of signalling application creation

This application is used to indicate the status of a load or an alarm signalling to the user.

The following example applies to the VARIOUS -> ON-OFF application but the same function can be also apply to the LIGHTS -> ON-OFF and/or ACCESSES AND PRESENCES -> WINDOWS / GATE AND GARAGE applications.

Click on  to select the environment with which to associate the application, select VARIOUS and then click on .

Select "ON-OFF".

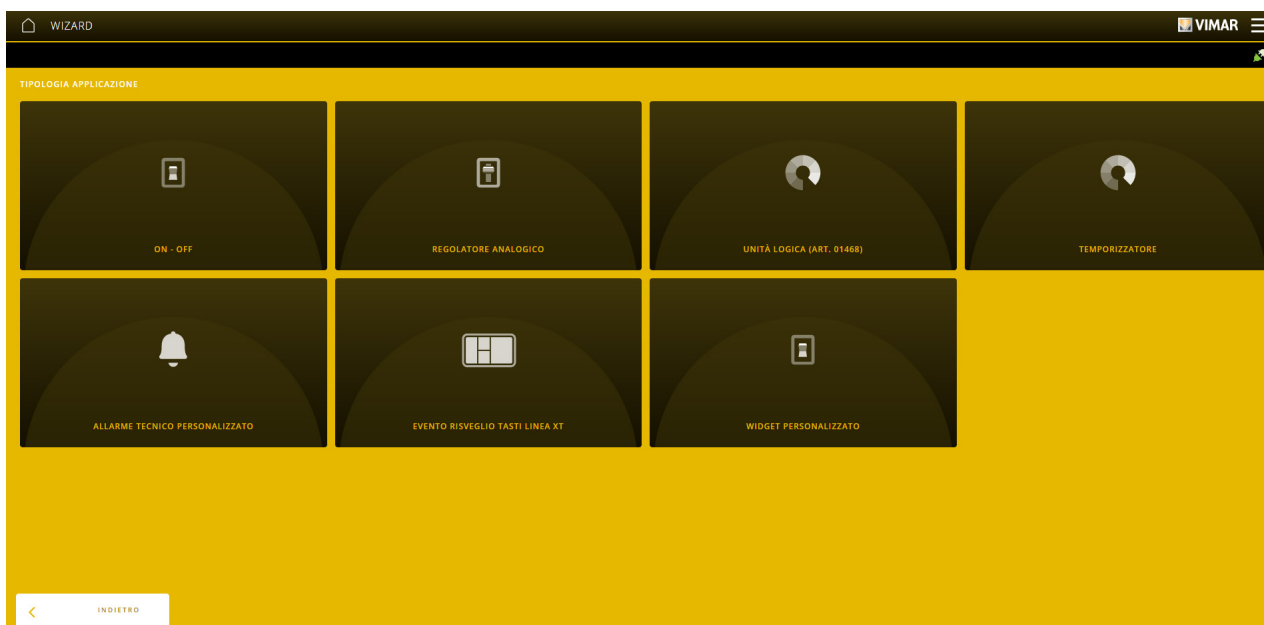

You will be prompted to enter the name that identifies the application within the environment.



Click on "END"; the screen displayed shows the application for signalling management.

This application will initially be empty and can be completed by adding:

- One or more functional units to be used for the light signalling to the user; the following can be used for this purpose:
 - the "LED" functional units of devices 21520.1 and 21540.1;
 - the "central LED matrix" functional units of the devices in the Linea XT series, when associated with the related rocker button.
- One or more functional units for the light signalling activation. For this purpose, a key can be used (if you want to control a load) or a contact interface (if you want to signal an alarm condition). In the absence of this type of functional unit, the function can always be performed using KNX integrations and/or logic programmes.

Configuration with View Pro App

4.4.8 Application creation examples to combine a rain sensor with a sprinkler system.



This section describes certain configuration options on how to use the rain information detected by a dedicated device to prevent the launch of one or more SPRINKLER SYSTEM type applications.

4.4.8.1 Example with use of KNX weather station (art. 01546)

In the event that the KNX weather station (art. 01546) is present and you wish to use the rain status it detects, proceed as follows:

1. Create the WEATHER STATION application as described in paragraph 4.6.
2. Once the application creation is complete, in the APPLICATION DETAILS view, click on  in the GROUP ADDRESSES section.
In the screen displayed, note down the group address associated with the DPTx_ItsRaining element:

INDIRIZZO	GRUPPO	DESCRIZIONE	TIPO
0x0F38	Gruppo	DPTx_ItsRaining	1.001

3. Create the SPRINKLER SYSTEM application as described in paragraph 4.3.8.
4. Once the application creation is complete, in the APPLICATION DETAILS view, click on  in the GROUP ADDRESSES section.
In the screen displayed, identify the row associated with the DPTx_IrrigationBlock element and click on :

INDIRIZZO	GRUPPO	DESCRIZIONE	TIPO
0x10BA	Gruppo Irrigazione	DPTx_IrrigationBlock	1.001

5. Set the group address you previously noted down and save the change by clicking on :

INDIRIZZO	GRUPPO	DESCRIZIONE	TIPO
0x0F38	Gruppo Irrigazione	DPTx_IrrigationBlock	1.001

This operation may be repeated for several sprinkler system applications; if this is the case, the information about the rain status generated by the KNX weather station will be used for the simultaneous blockage of each one.

4.4.8.2 Example with use of external rain sensor configured in SPRINKLER SYSTEM application

In the presence of an external rain detection sensor that can be interfaced via voltage-free contact in the By-me Plus system (for instance using an input of device 01475 or similar), this functional unit can be configured within the sprinkler system application.

This approach should be used if you intend to use the data generated by the rain sensor for a single sprinkler system application; with this approach, the status of the rain sensor will not be displayed on the View App or on the touch screens. Alternatively, please refer to paragraph 4.4.8.3.

1. Enrol the device connected to the third-party sensor as described in paragraph 4.2.
2. Create the SPRINKLER SYSTEM application as described in paragraph 4.3.8.
3. Select the SPRINKLER GROUP and click on . In the window displayed, select the device you previously enrolled and identify the functional unit relating to the input used.

Configuration with View Pro App

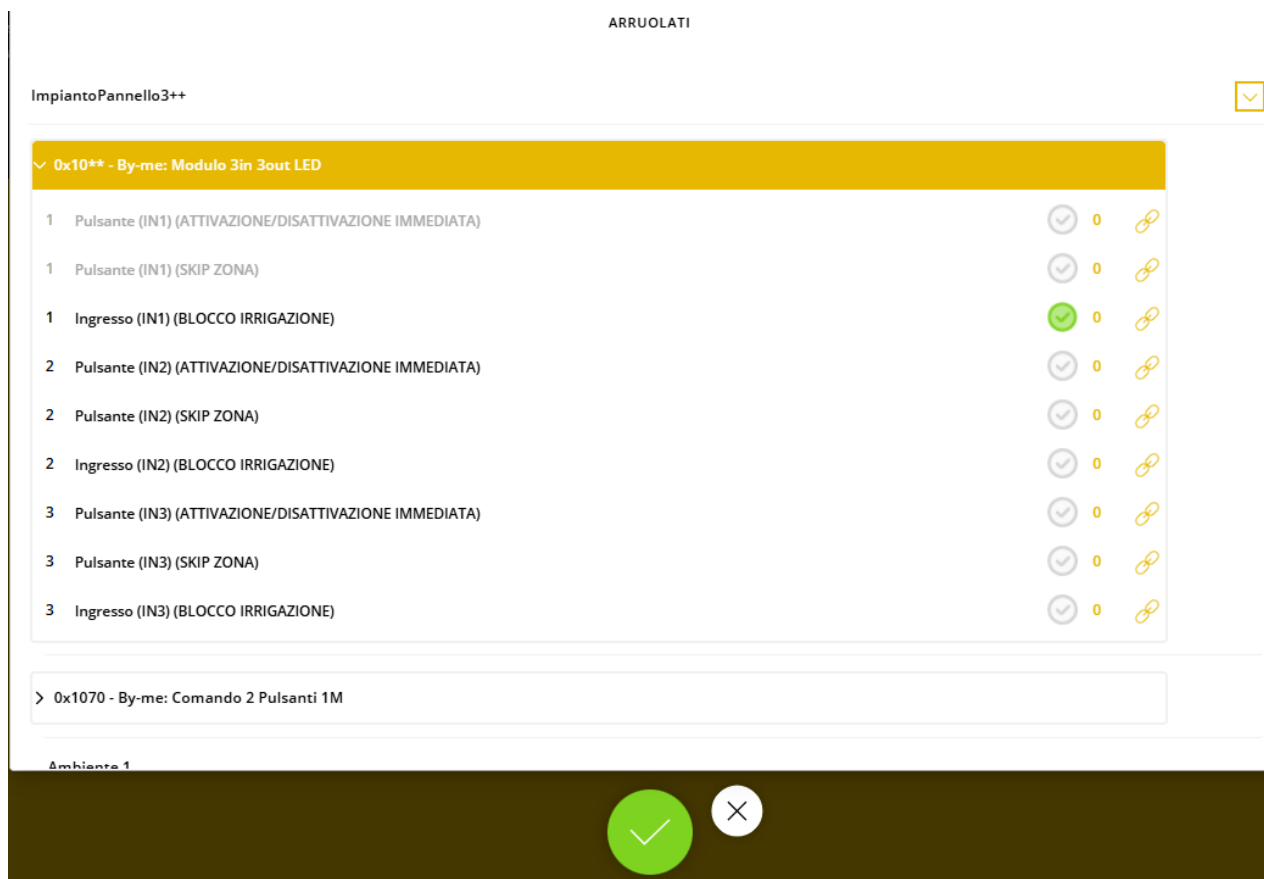

4. Select the option with the SPRINKLER SYSTEM LOCK indication and complete the configuration process by selecting .

4.4.8.3 Example with use of external rain sensor configured in SENSORS application

In the presence of an external rain detection sensor that can be interfaced via voltage-free contact in the By-me Plus system (for instance using an input of art. 01475 or similar), this functional unit can be configured in the sensors application and subsequently connected to the sprinkler system application.

This approach should be used if you intend to use the data generated by the rain sensor for a several sprinkler system applications and/or if you are interested in displaying the status of the rain sensor on the View App and on the touch screens. Alternatively, please refer to paragraph 4.4.8.2.

1. Enrol the device connected to the third-party sensor as described in paragraph 4.2 and then create the SENSORS -> CONTACT application as described in paragraph 4.3.6 using the device enrolled.

2. Once the application creation is complete, in the APPLICATION DETAILS view, click on  in the GROUP ADDRESSES section.

In the screen displayed, note down the group address associated with the DPTx_ContactClosed element:

INDIRIZZO	GRUPPO	DESCRIZIONE	TIPO
0x115D	Gruppo	DPTx_ContactClosed	1.001

3. Create the SPRINKLER SYSTEM application as described in paragraph 4.3.8.

4. Once the application creation is complete, in the APPLICATION DETAILS view, select the  button in the GROUP ADDRESSES section.

In the screen displayed, identify the row associated with the DPTx_IrrigationBlock element and click on  :

INDIRIZZO	GRUPPO	DESCRIZIONE	TIPO
0x10BA	Gruppo Irrigazione	DPTx_IrrigationBlock	1.001

5. Set the group address you previously noted down and save the change by clicking on  :

INDIRIZZO	GRUPPO	DESCRIZIONE	TIPO
0x115D	Gruppo Irrigazione	DPTx_IrrigationBlock	1.001

This operation may be repeated for several sprinkler system applications; if this is the case, the information about the rain status generated by the rain sensor will be used for the simultaneous blockage of each one.

Configuration with View Pro App

4.4.9 Example of master group type application creation

This application is used to control a set of actuators already configured in other applications, from one or more controls. Usage examples of this function include:

- having a control that allows the movement of all the roller shutters in the home to be opened/closed/stopped, each one configured in its own application;
- having a control that turns all the lights on one floor on/off, each one configured in its own application, regardless of their type (on/off, dimmable, etc.).

These applications are designed for the sole control from physical devices and, since they do not envisage a status concept, they are not available for supervision on the View App and on touch screens; they can however be used via the logic program editor to create advanced functions.

In addition to a main application, each actuator can be configured in up to a maximum of 3 master groups.

4.4.9.1 Example of lights master group type application creation

To create the function in question, it is advisable (although not necessary) to proceed as follows:

- First of all create the “main” applications by configuring the desired actuators and controls; see paragraph 4.3.3 for further details.
- Next, create the lights master group application, configuring within it the specific controls of this application and the actuators you previously configured.

1. Click on to select the environment with which to associate the application, select LIGHTS and then click on .

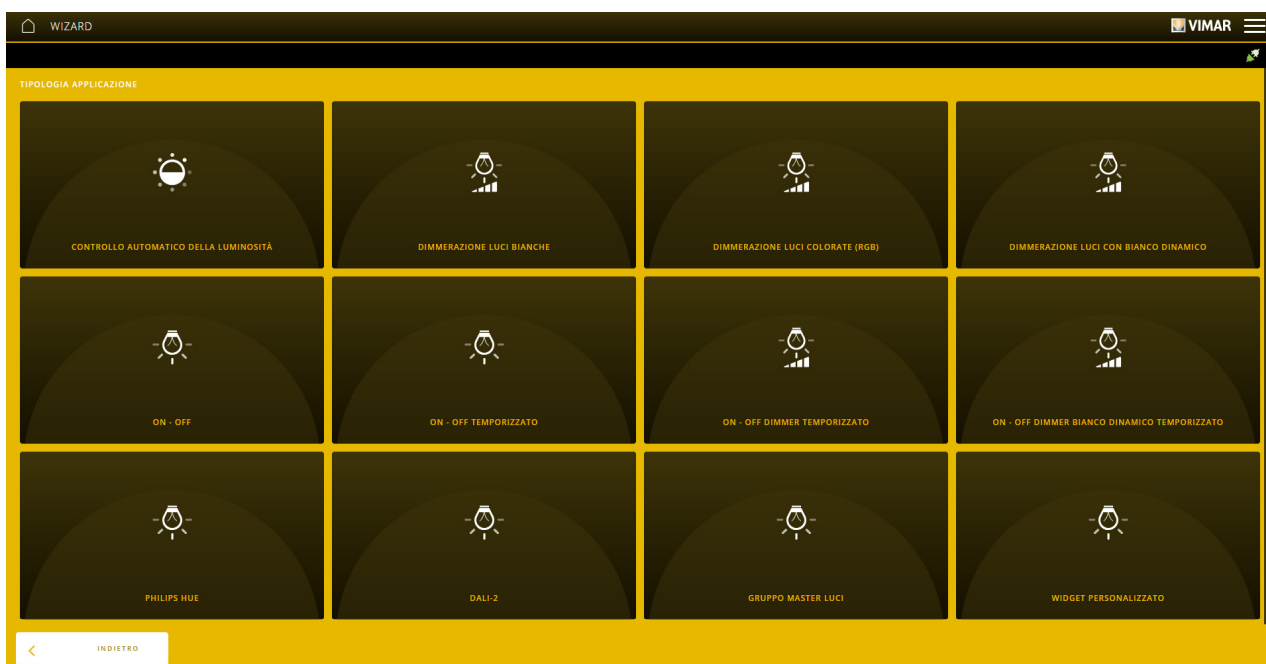

2. Select LIGHTS MASTER GROUP.

3. Enter the name that identifies the application within the environment.

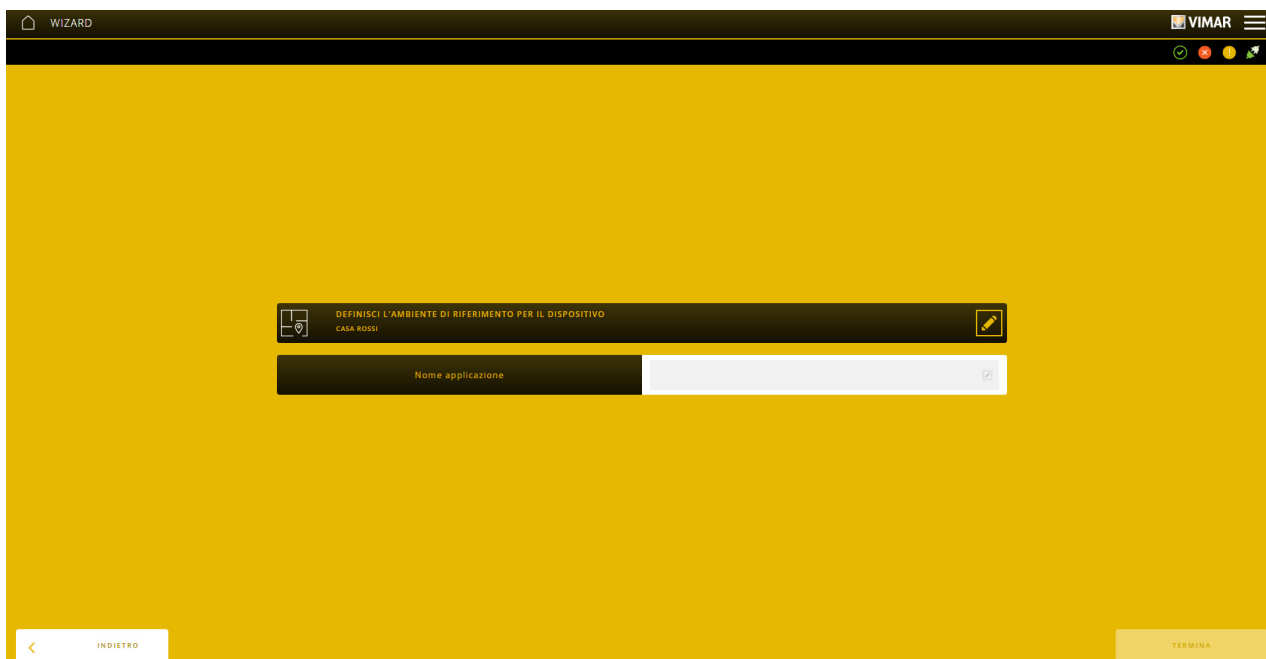

Configuration with View Pro App

4. Click on "END"; the screen displayed shows the application for managing the lights master group.

This application will initially be empty and can be completed by adding:

- One or more actuator type functional units, both those already configured in other applications as well as free ones. You will be able to configure all types of actuators in the lights master group (By-me, DALI-2, PhilipsHue) as well as all configurations supported (on/off, dimmable, RGB dimmable, timed, etc.). The actuators already used will be displayed with the configuration defined in the "main" application. The free ones, on the other hand, will be displayed with all the possible configurations they can assume in each LIGHTS type application in which they are potentially configurable.
- One or more controls for the overall control of the actuators configured within the application. Each control is displayed with all the possible configurations it can assume in each LIGHTS type application; depending on the chosen configuration, the action on the control can be received by all or part of the actuators present in the application (depending on their configuration).

The following table indicates the possible actuator configurations and the "main" reference application types in which these configurations can be used (all belonging to the Lights domain):

Actuator configuration	"Main" reference application(s)
ON - OFF	ON-OFF WHITE LIGHT DIMMING COLOURED (RGB) LIGHT DIMMING PHILIPS HUE -> 1-WAY SWITCH DALI -> ON-OFF
DIMMER	WHITE LIGHT DIMMING AUTOMATIC BRIGHTNESS CONTROL' PHILIPS HUE -> DIMMER DALI -> MONOCHROME DIMMER
TUNABLE WHITE DIMMER	TUNABLE WHITE LIGHT DIMMING PHILIPS HUE -> TUNABLE WHITE DIMMER DALI -> TUNABLE WHITE (TW) DIMMER
RGB DIMMER RGBW DIMMER	COLOURED (RGB) LIGHT DIMMING PHILIPS HUE -> RGB/RGBW DIMMER DALI -> RGB/RGBW DIMMER
TUNABLE RGB DIMMER	PHILIPS HUE -> TUNABLE RGB/RGBW DIMMER
COMPLETE ACTUATOR	TIMED ON-OFF (all variants)
COMPLETE ACTUATOR (TIMED DIMMER)	TIMED DIMMER ON-OFF (all variants) TIMED TUNABLE WHITE DIMMER ON-OFF (all variants)
TIMED DIMMER	TIMED DIMMER ON-OFF (all variants)
TIME TUNABLE WHITE DIMMER	TIMED TUNABLE WHITE DIMMER ON-OFF (all variants)

The following table indicates the possible configurations of the controls and the actions performed by the devices:

Button configuration	Action on short press	Performed by	Action on long press	Performed by
ON - OFF	Power on/off control sending	All devices	-	-
ONE-POSITION STABLE	Timed power on/off control sending	Only devices configured in timed applications	-	-
TWO-POSITION STABLE AND ONE-POSITION STABLE	Power on/off control sending	All devices	Timed power on/off control sending	Only devices configured in timed applications
ONE-POSITION STABLE AND TWO-POSITION STABLE	Timed power on/off control sending	Only devices configured in timed applications	Power on/off control sending	All devices
DIMMER	Power on/off control sending	All devices	Brightness adjustment control sending	All devices, except the relays
ONE-POSITION STABLE AND DIMMER	Timed power on/off control sending	Only devices configured in timed applications	Brightness adjustment control sending	All devices, except the relays
COLOUR TEMPERATURE CONTROL	Power on/off control sending	All devices	Colour temperature control sending	All "tunable white" type devices
ONE-POSITION STABLE AND COLOUR TEMPERATURE	Timed power on/off control sending	Only devices configured in timed applications	Colour temperature control sending	All "tunable white" type devices
HUE CONTROL	Power on/off control sending	All devices	Colour adjustment control sending	All "RGB" type devices, except DALI (which do not support the function)
SATURATION CONTROL	Power on/off control sending	All devices	Saturation adjustment control sending	All "RGB" type devices, except DALI (which do not support the function)

Configuration with View Pro App

4.4.9.2 Example of roller shutters master group type application creation

To create the function in question, it is advisable (although not necessary) to proceed as follows:

- First of all create the "main" applications by configuring the desired actuators and controls; see paragraph 4.3.2 for further details.
- Next, create the roller shutters master group application, configuring within it the specific controls of this application and the actuators you previously configured.

1. Click on  to select the environment with which to pair the application, select BLINDS AND ROLLER SHUTTERS and then click on .

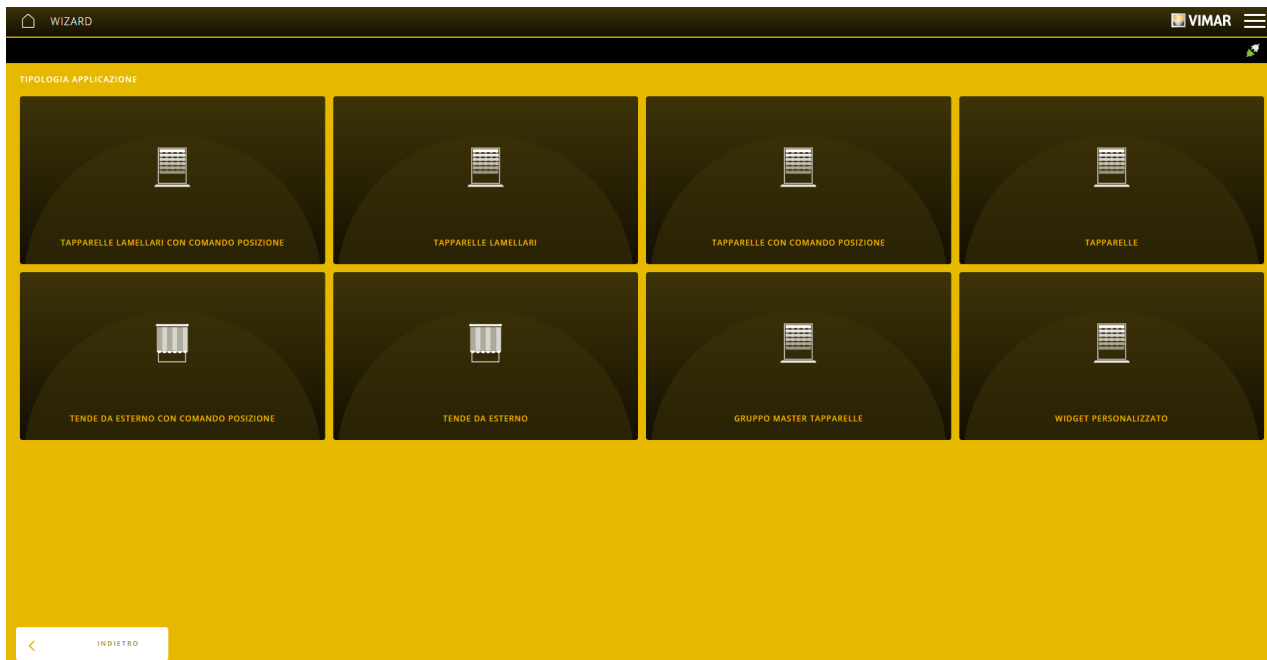

2. Select ROLLER SHUTTERS MASTER GROUP.

3. Enter the name that identifies the application within the environment.

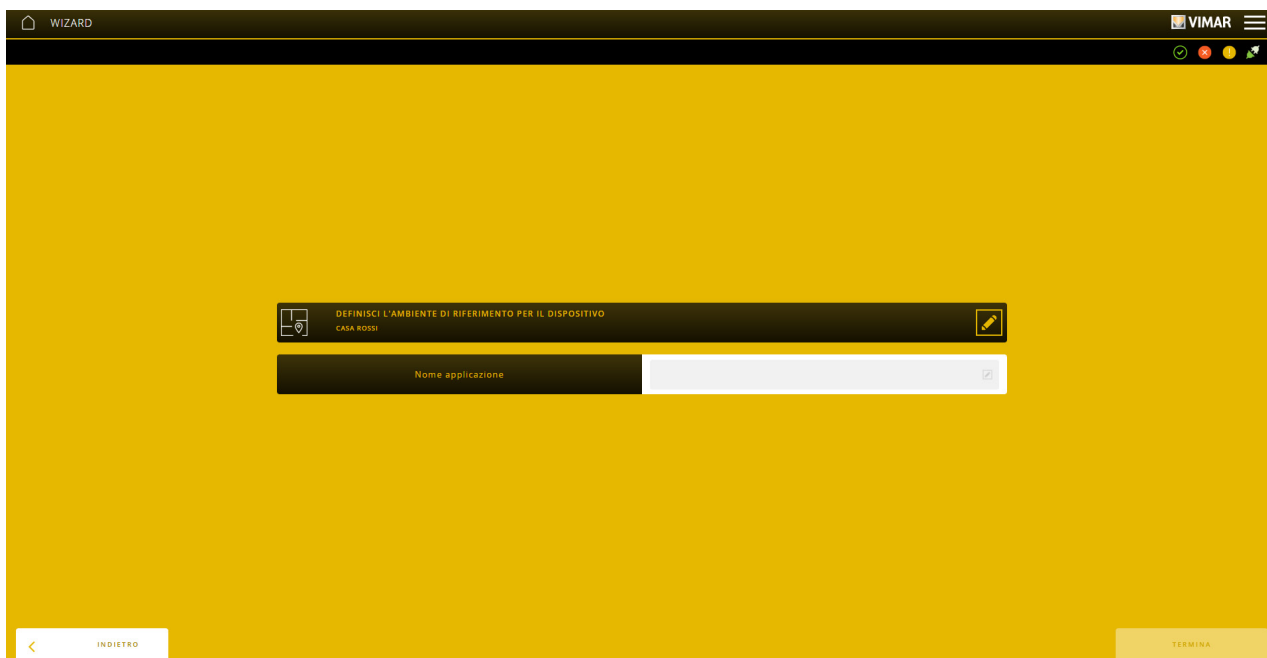

4. Click on "END"; the screen displayed shows the application for managing the roller shutters master group.

This application will initially be empty and can be completed by adding:

- One or more actuator type functional units, both those already configured in other applications as well as free ones. You will be able to configure actuators in all possible configurations (roller shutters with/without position and/or with/without slats, blinds with/without position) in the roller shutters master group. The actuators already used will be displayed with the configuration defined in the "main" application. The free ones, on the other hand, will be displayed with all the possible configurations they can assume in each BLINDS and ROLLER SHUTTERS type application in which they are potentially configurable.
- One or more controls for the overall control of the actuators configured within the application. Each control is displayed with a single possible configuration; the action on the slats (brief press of the control with actuators not in motion) is only received by the actuators with slat configurations.

Configuration with View Pro App

4.4.10 Example of room status signalling via logic application

This application is used to signal the statuses of a hotel room and the interaction with the latter via physical controls; it is achieved via a logic inside the home automation system gateway and allows the following functions to be controlled:

- “Do Not Disturb” notification
- “Make Up Room” notification
- “Room Service” notification
- “Doorbell” management

1. Click on  to select the environment with which to pair the application, select ACCESSES AND PRESENCES and then click on .

2. Select ROOM STATUS NOTIFICATION.

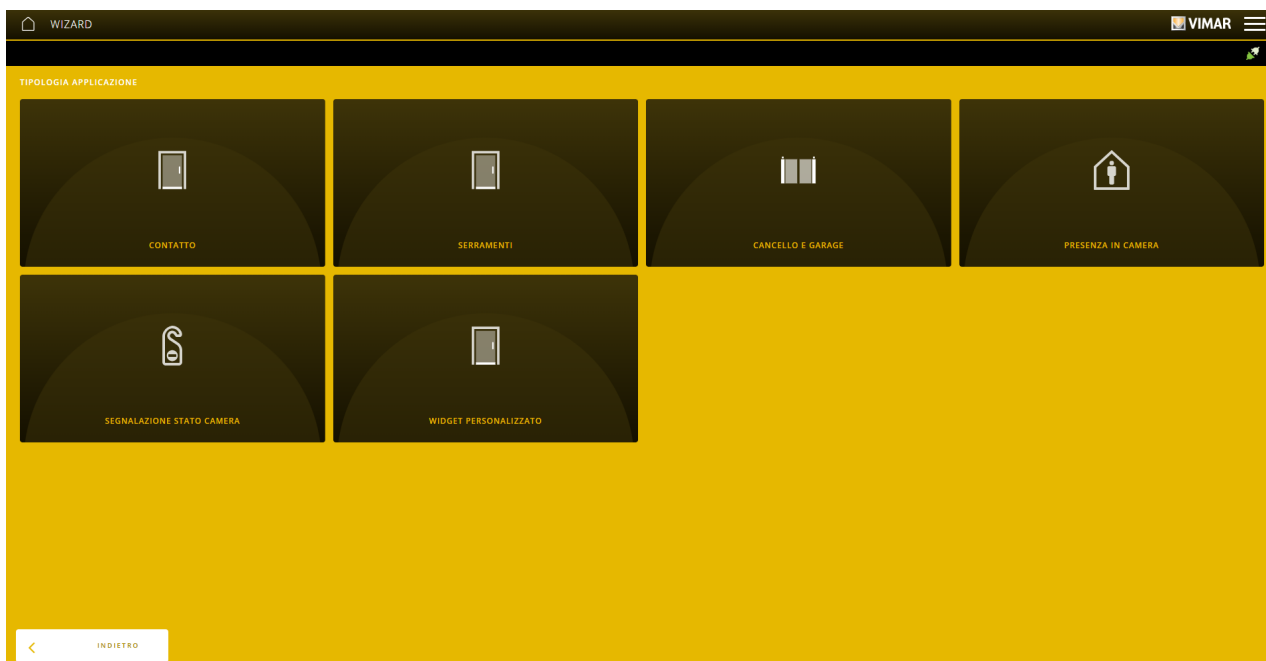

3. Select ROOM STATUS NOTIFICATION (Logic).



Configuration with View Pro App

4. Select the functions you wish to configure within the application, making sure you select at least one; once this is done, click on CONTINUE.

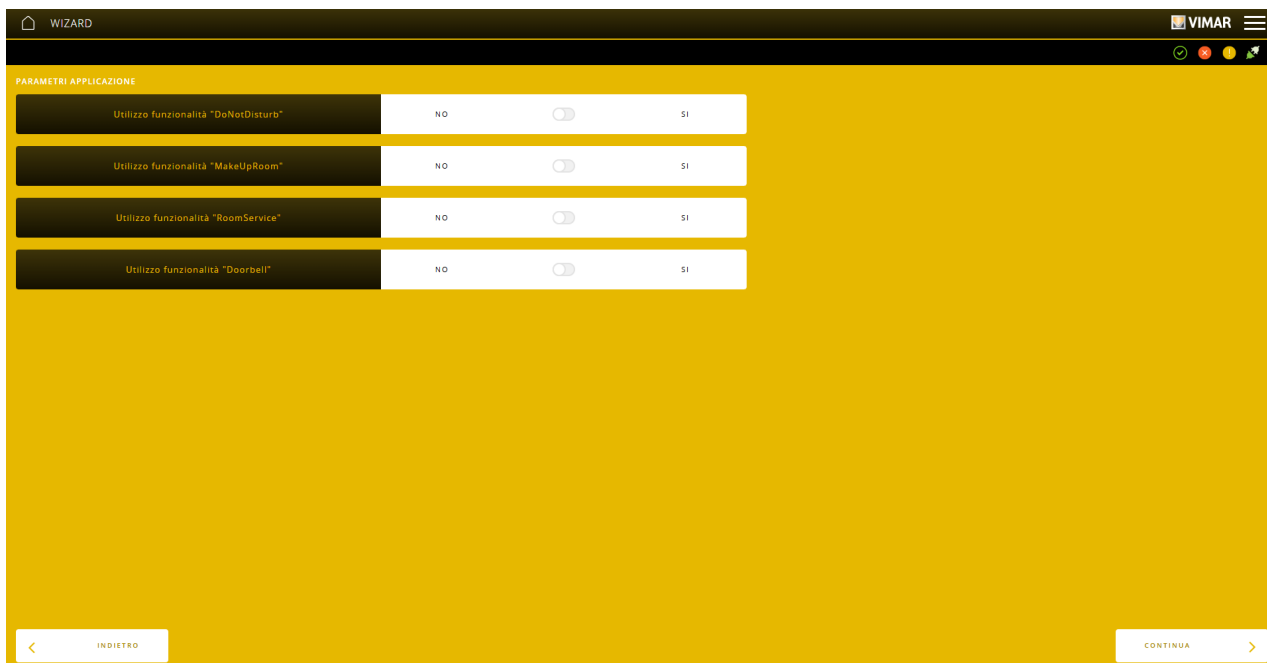

5. Enter the name that identifies the application within the environment.

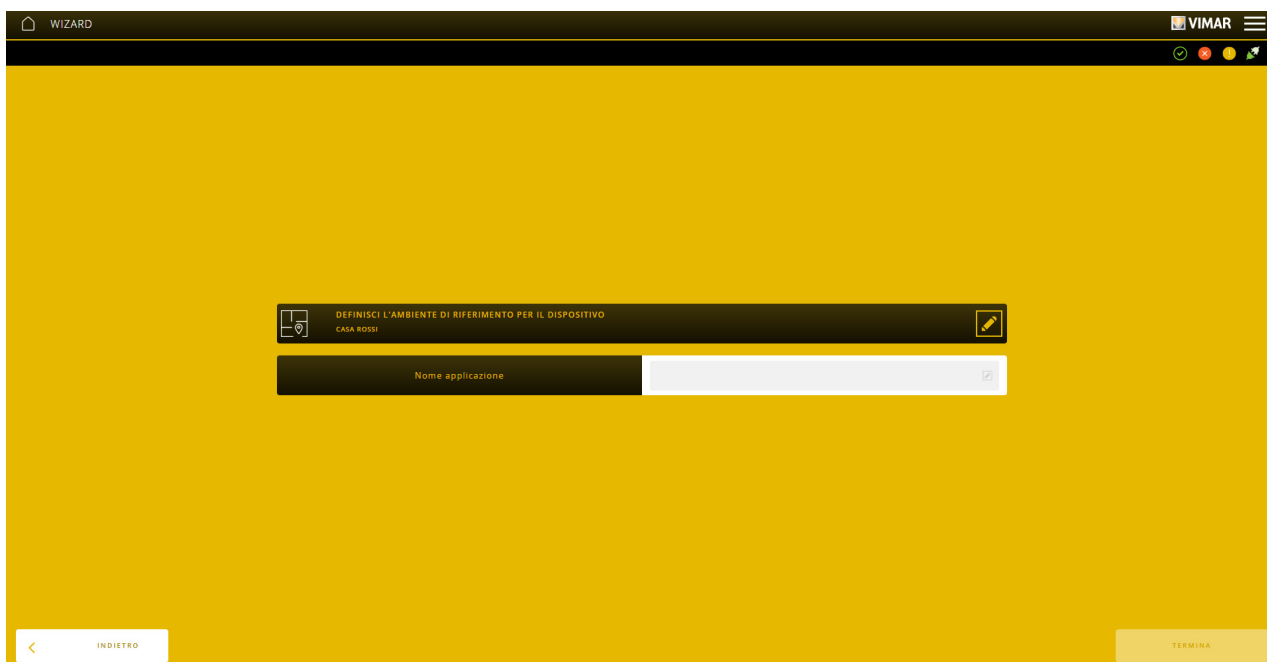

6. Click on "END"; the screen displayed shows the application for room status notification management.

The application will be created with one group for every function chosen during the configuration wizard. Below is a description of each of the possible groups:

- Do Not Disturb group: allows you to interact with the "DoNotDisturb" function. In this group, you can configure the actuators (LEDs and/or relays) for signalling the status of the function and the controls for its on/off control. When this function is enabled, the logic disables the "MakeUpRoom" and "RoomService" functions if they were enabled.
- Make up Room group: allows you to interact with the "MakeUpRoom" function. In this group, you can configure the actuators (LEDs and/or relays) for signalling the status of the function and the controls for its on/off control. When this function is enabled, the logic disables the "DoNotDisturb" function if it was enabled.
- Room Service group: allows you to interact with the "RoomService" function. In this group, you can configure the actuators (LEDs and/or relays) for signalling the status of the function and the controls for its on/off control. When this function is enabled, the logic disables the "DoNotDisturb" function if it was enabled.
- Doorbell group: allows you to interact with the "Doorbell" function. In this group, you can configure the actuators (LEDs and/or relays) for signalling the status of the function and the controls for its on/off control; the controls are configured by default in such a way that they send the ON control when the push button is pressed and the OFF control when the same is released (this behaviour can be modified using parameters). When the "DoNotDisturb" function is enabled, the "Doorbell" function is inhibited.

Configuration with View Pro App

4.4.11 Example of presence in room detection application creation



This application is used to detect the presence in a hotel room and to perform the activation of scenarios according to its variation; it is achieved via a logic within the home automation system gateway.

The application makes the presence in room status available in the View App and on the touch screens; to enable the scenarios according to the variation of the presence in room status, you also need to configure scenarios that use activators that the application makes available to the View App:

- First guest entry (day): action performed upon guest entry after checking in (daytime).
- First guest entry (night): action performed upon guest entry after checking in (at night).
- Staff entry: action performed upon entry of a member of staff in the room.
- Guest presence configuration call-up: action performed upon all subsequent guest entries in the room; the scenario associated with this activator is "dynamic", in other words it is re-saved every time the guest exits the room and called upon when they re-enter. This function can be used to save the status of the actuators set by the user and to call it up when they return (for instance because the room is set to energy saving mode during the guest's absence).
- Absence configuration call-up: action performed upon guest exit from the room, to set it to energy saving condition.
- Room not booked configuration call-up: action performed upon guest exit from the room after checking out.

Two variants of this function can also be set:

- «With card reader», whereby the presence in room status is determined according to the insertion status of a card in the related pocket.
- «Virtual», whereby the presence in room status is determined as a combination of the door open status and the detection of a motion sensor.

1. Click on  to select the environment with which to pair the application, select ACCESSES AND PRESENCES and then click on .
2. Select PRESENCE IN ROOM.

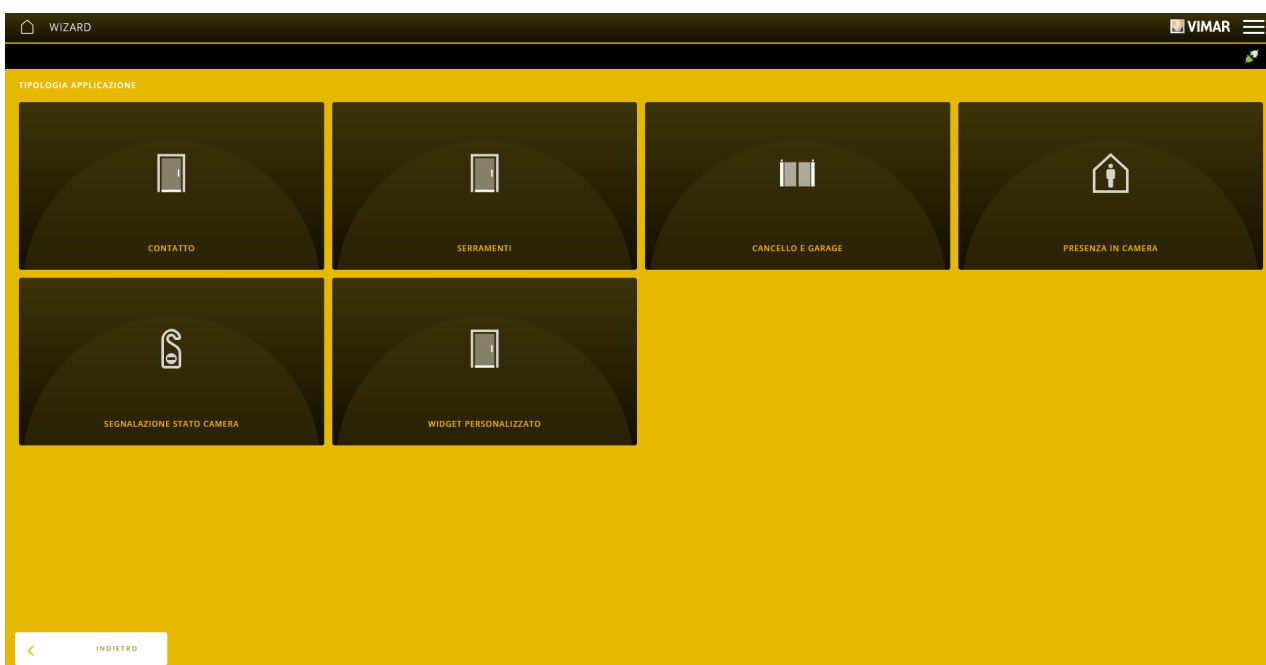

3. Select PRESENCE IN ROOM (WITH CARD READER) or PRESENCE IN ROOM (VIRTUAL).

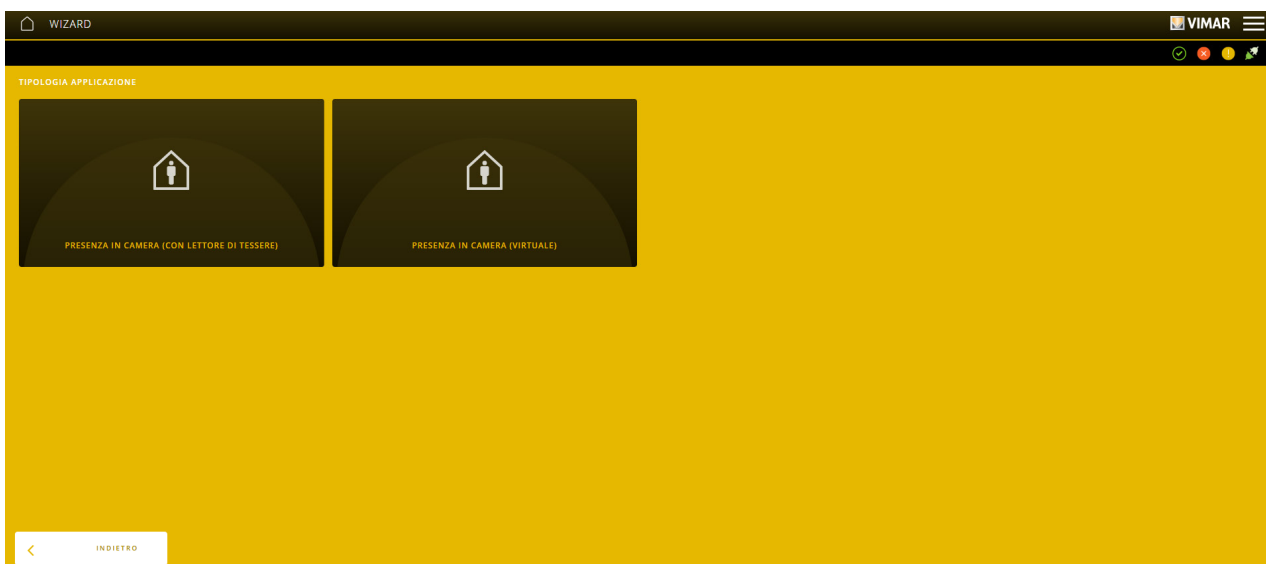

Configuration with View Pro App

4. Enter the name that identifies the application within the environment.

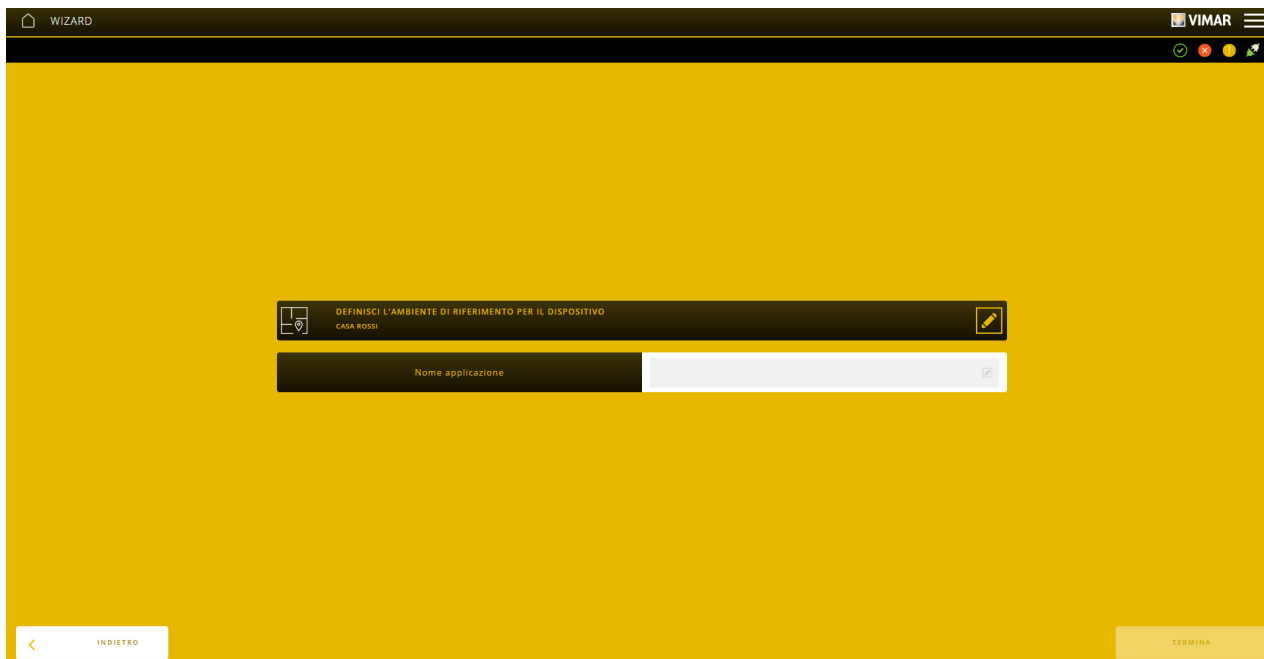

6. Click on "END"; the screen displayed shows the application for presence in room detection management.

The application will be created with a set of groups to manage the various inputs/outputs of the function; below is a description of each of the possible groups.

Controller Group

Used to configure the operating parameters of the logic; no functional unit can be configured in this group.

The "Controller" functional unit parameters are:

- ABSENCE DETECTION TIME: time value, in seconds, which the logic waits in the absence of a card insertion and/or movement to proclaiming the end of the presence in room status and perform the connected actions
- FORCED DOOR CLOSING TIME: time value, in seconds, applicable only to the "virtual" variant, which the logic waits before considering the door as closed at the logical level even if the actual datagram with the closing event never arrived
- TYPE OF ACCESS RECOGNITION ENABLING: enables the differentiation of the type of user gaining access (information provided in the "Guest Entry" and "Staff Entry" groups). When it is disabled, a guest type access is assumed by default and the related scenarios are called up

Card Status Group

Applicable only to the "with card" variant, it makes it possible to provide the card insertion in a pocket status; it is an essential group for the proper functioning of the logic programme and must therefore always be configured.

This information can be provided to the logic in one of the following ways:

- By configuring any "entry" type functional unit (e.g. art. code 01475 and similar) connected to the pocket
- By sending, on the part of an external device/system connected to the KNX bus, a 1.xxx type datagram. The value sent must be mapped as follows:
 - 0 ➔ Card not inserted
 - 1 ➔ Card inserted

Upon startup, the home automation system gateway initialises its logic by reading the status of this function; if an external device or system connected to the KNX bus is used to provide this information, it is essential that the value can be read at startup to ensure the status is correctly initialised.

Door Status Group

Applicable only to the "virtual" variant, it makes it possible to provide the door open/closed status; it is an essential group for the proper functioning of the logic programme and must therefore always be configured.

This information can be provided to the logic in one of the following ways:

- By configuring any "entry" type functional unit (e.g. art. code 01475 and similar) connected to a sensor installed on the door
- By sending, on the part of an external device/system connected to the KNX bus, a 1.xxx type datagram. The value sent must be mapped as follows:
 - 0 ➔ Door closed
 - 1 ➔ Door open

Upon startup, the home automation system gateway initialises its logic by reading the status of this function; if an external device or system connected to the KNX bus is used to provide this information, it is essential that the value can be read at startup to ensure the status is correctly initialised.

Configuration with View Pro App

Motion Sensor Status Group

Applicable only to the “virtual” variant, it makes it possible to provide the detection status on the part of a sensor present in the room; it is an essential group for the proper functioning of the logic programme and must therefore always be configured.

This information can be provided to the logic in one of the following ways:

- By configuring any “entry” type functional unit (e.g. art. 01475 and similar) connected to a motion sensor (e.g. radar/PIR).
- By sending, on the part of an external device/system connected to the KNX bus, a 1.xxx type datagram. The value sent must be mapped as follows (it is essential that the external device sends both values according to its own internal status):
 - 0 ➔ Motion not detected
 - 1 ➔ Motion detected

Upon startup, the home automation system gateway initialises its logic by reading the status of this function; if an external device or system connected to the KNX bus is used to provide this information, it is essential that the value can be read at startup to ensure the status is correctly initialised.

It is necessary to account for the presence detection time of the sensor used and to configure the ABSENCE DETECTION TIME parameter in the “Controller” group accordingly (this value should be set higher, ideally with a small margin). For example, assuming a sensor has a 1-minute timeout for detecting absence after movement, the ABSENCE DETECTION TIME parameter should be set to a value such as 1 minute and 10 seconds.

Check-in Group

This allows the logic to be informed that the guest check-in procedure for the reserved room has been completed. This should be considered optional information within the logic programme; if this information is missing, the system will not perform the actions associated with the check-in status.

This information can be provided to the logic programme in one of the following ways:

- By configuring any “entry” type functional unit (e.g. art. 01475 and similar) connected to a device that generates this information.
- By sending, on the part of an external device/system connected to the KNX bus, a 1.xxx type datagram. For logic purposes, only the value 1 is considered (indicating that check-in is active).

The actions connected to the check-in event are differentiated based on the system's day/night status, which is managed by the home automation system gateway via the dedicated system datapoint. In the event that this information is unavailable, the status will automatically default to “day”.

Check-out Group

This allows the logic to be informed that the guest check-out procedure for the reserved room has been completed. This should be considered optional information within the logic programme; if this information is missing, the system will not perform the actions associated with the check-out status.

This information can be provided to the logic programme in one of the following ways:

- By configuring any “entry” type functional unit (e.g. art. 01475 and similar) connected to a device that generates this information.
- By sending, on the part of an external device/system connected to the KNX bus, a 1.xxx type datagram. For logic purposes, only the value 1 is considered (indicating that check-out is active).

Guest Entry Group

This enables the logic to be informed when a user identified as a guest enters the room. This should be considered optional information within the logic programme; in the absence of this data, the decision logic will automatically default to “Guest Entry”.

This information is treated as mutually exclusive with the data provided by the “Staff Entry” group; therefore, receiving one signal will reset the other, and vice versa.

This information can be provided to the logic programme in one of the following ways:

- By configuring any “entry” type functional unit (e.g. art. 01475 and similar) connected to a device that generates this information.
- By sending, on the part of an external device/system connected to the KNX bus, a 1.xxx type datagram. For logic purposes, only the value 1 is considered (indicating that this type of access has been made).
- By sending the required data via a dedicated logic programme created within the Cloud logic editor. Following the creation of the presence in room application, a specific logic block will become available (found under the Accesses and Presences category in the editor); this allows the access type information to be provided as an input to the application. This method should be used instead of the two previously described options in cases where the access type data must be retrieved by combining information from multiple sources (e.g., the simultaneous closing of several relays/contacts to signal the access type).

Staff Entry Group

This enables the logic to be informed when a user identified as a member of staff enters the room. This should be considered optional information within the logic programme; in the absence of this data, the decision logic will automatically default to “Guest Entry”.

This information is treated as mutually exclusive with the data provided by the “Guest Entry” group; therefore, receiving one signal will reset the other, and vice versa.

This information can be provided to the logic programme in one of the following ways:

- By configuring any “entry” type functional unit (e.g. art. 01475 and similar) connected to a device that generates this information.
- By sending, on the part of an external device/system connected to the KNX bus, a 1.xxx type datagram. For logic purposes, only the value 1 is considered (indicating that this type of access has been made).
- By sending the required data via a dedicated logic programme created within the Cloud logic editor. Following the creation of the presence in room application, a specific logic block will become available (found under the Accesses and Presences category in the editor); this allows the access type information to be provided as an input to the application. This method should be used instead of the two previously described options in cases where the access type data must be retrieved by combining information from multiple sources (e.g., the simultaneous closing of several relays/contacts to signal the access type).

Configuration with View Pro App

Presence in Room Group

Provides the output of the presence in room status calculation performed by the home automation system gateway. It is also possible to use the status generated by this group for additional operations in the following ways:

- By configuring any relay type functional unit (across all supported types) or signalling matrix (for example, art. 21520.1/21540.1 or XT controls) to be activated based on the presence in room status
- By monitoring the 1.xxx type datagram generated by the home automation system gateway on an external device/system connected to the KNX bus whenever the presence in room status changes. The value sent must be mapped as follows:
 - 0 ➔ No presence detected
 - 1 ➔ Presence detected

Configuration with View Pro App

4.5 Integration of By-alarm Plus and video door entry devices with By-me Plus applications

The View Pro App is designed for the devices in the burglar alarm system and/or video door entry system to interact in order to create functions involving devices that belong to different systems. Select BY-ALARM INTEGRATION DEVICES to display the page relating to the By-alarm Plus gateway.

N.B. The burglar alarm system gateway 03812 can be integrated in systems with home automation system gateway 01410-0411 ver. 1.12.x and later.

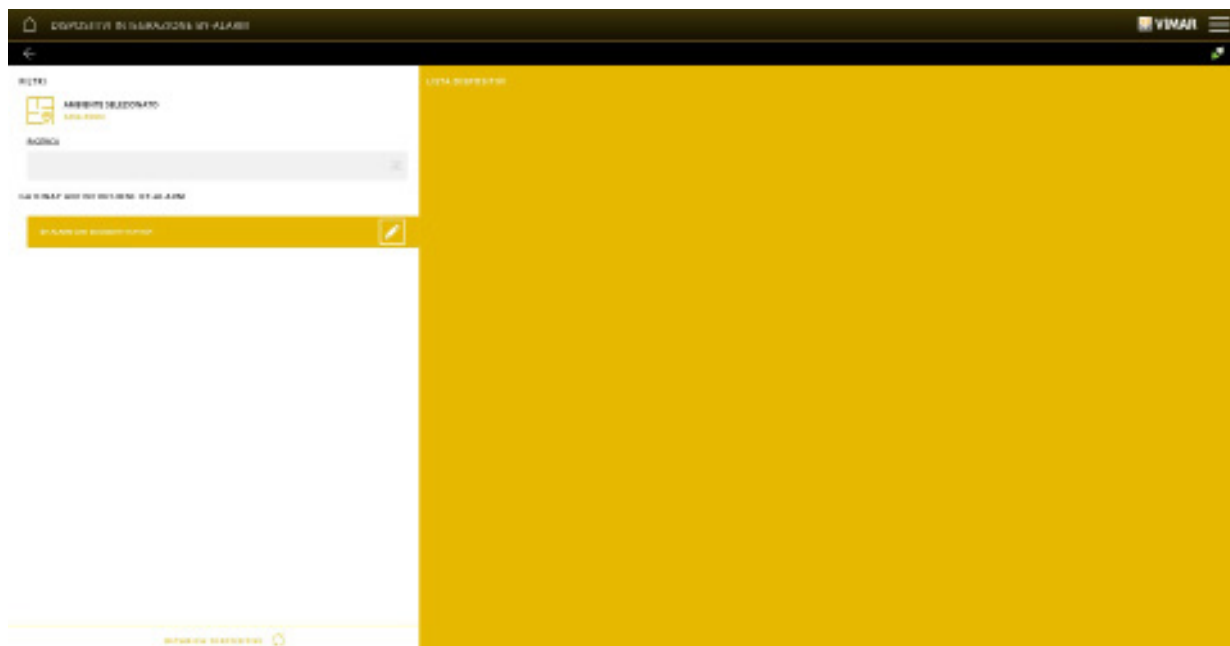

To view the elements configured in the By-alarm Plus gateway click on and in item integration system PIN enter the USER CODE set in the burglar alarm system. As this code is entered by the installer, it only needs the permissions required to view the status of the areas and zones used for the integration (it is therefore not necessary to enable alarm arming or disarming permissions, which remain the sole property of the end-user).



N.B.: As the USER CODE is not saved in the backup, it must be re-entered if the gateway is replaced to re-enable the integration.

Select "UPDATE INTEGRATION"; all the devices in the By-alarm Plus system and the zones to which they belong will be displayed; when an application is created, these devices will also be displayed together with those of the By-me Plus system.

Caution: Before performing the "ENABLE/UPDATE" control, log out from the By-alarm Plus Manager software.

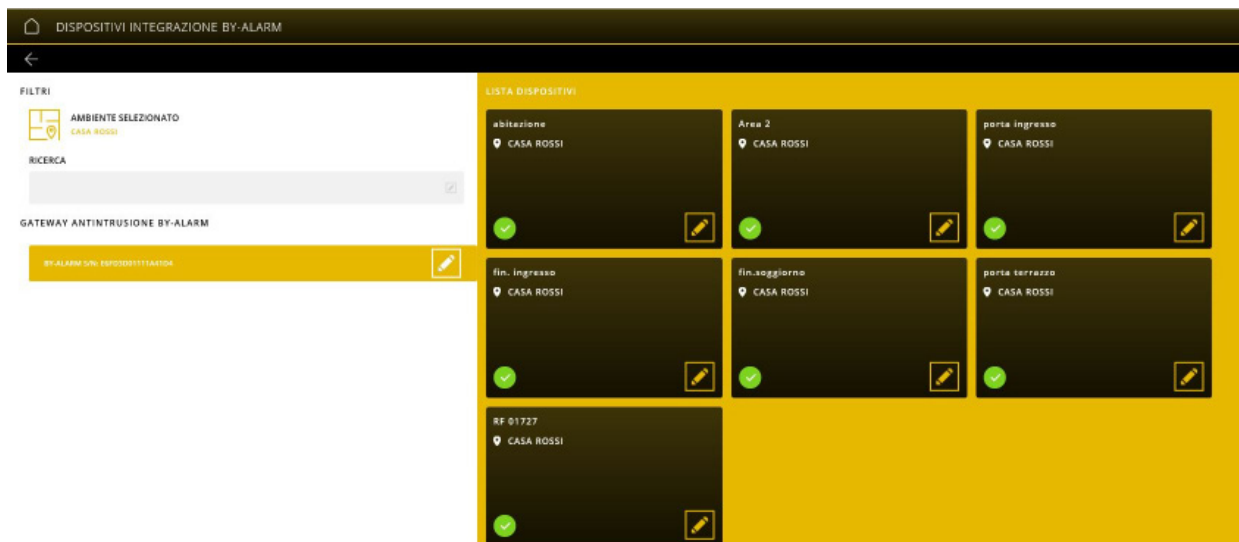

Configuration with View Pro App

Select  for each device to display the related functional units.

For instance, the functional units of the "entrance door" detector are the following:

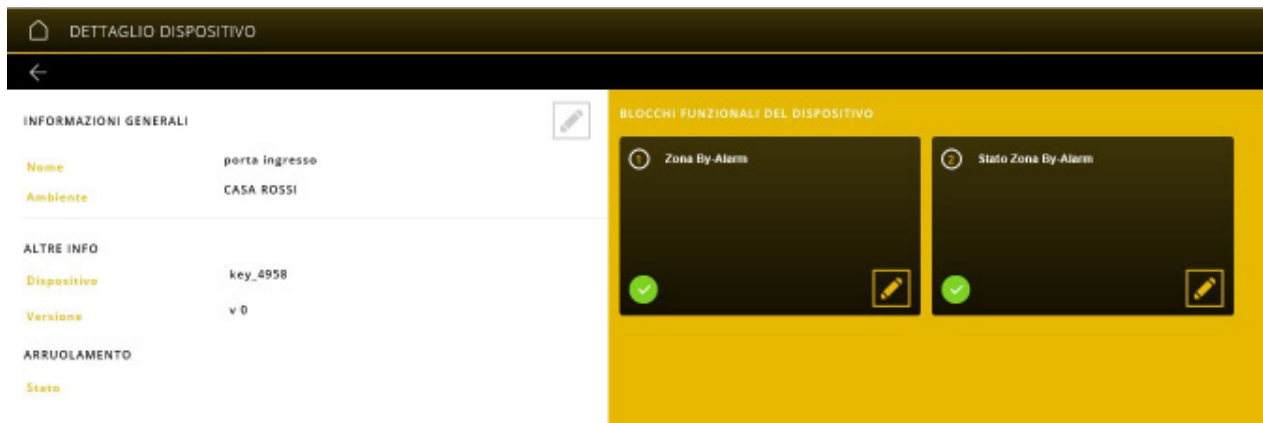

The "By-alarm zone" functional unit defines presence detection while the "By-alarm zone status" defines the sending of the alarm message.

Now create an application which, for example, with the burglar alarm system deactivated, switches on the entrance door light when the IR detector detects a person passing. From the main screen, click on APPLICATIONS, select the environment and then select LIGHTS; click on  and then on ON-OFF.

Within this application, referred to as PIR Light, enter the functional unit of the relay that controls the entrance light (in this case OUT2 of module 01470.1) and that of the presence detector (in this case By-alarm zone).

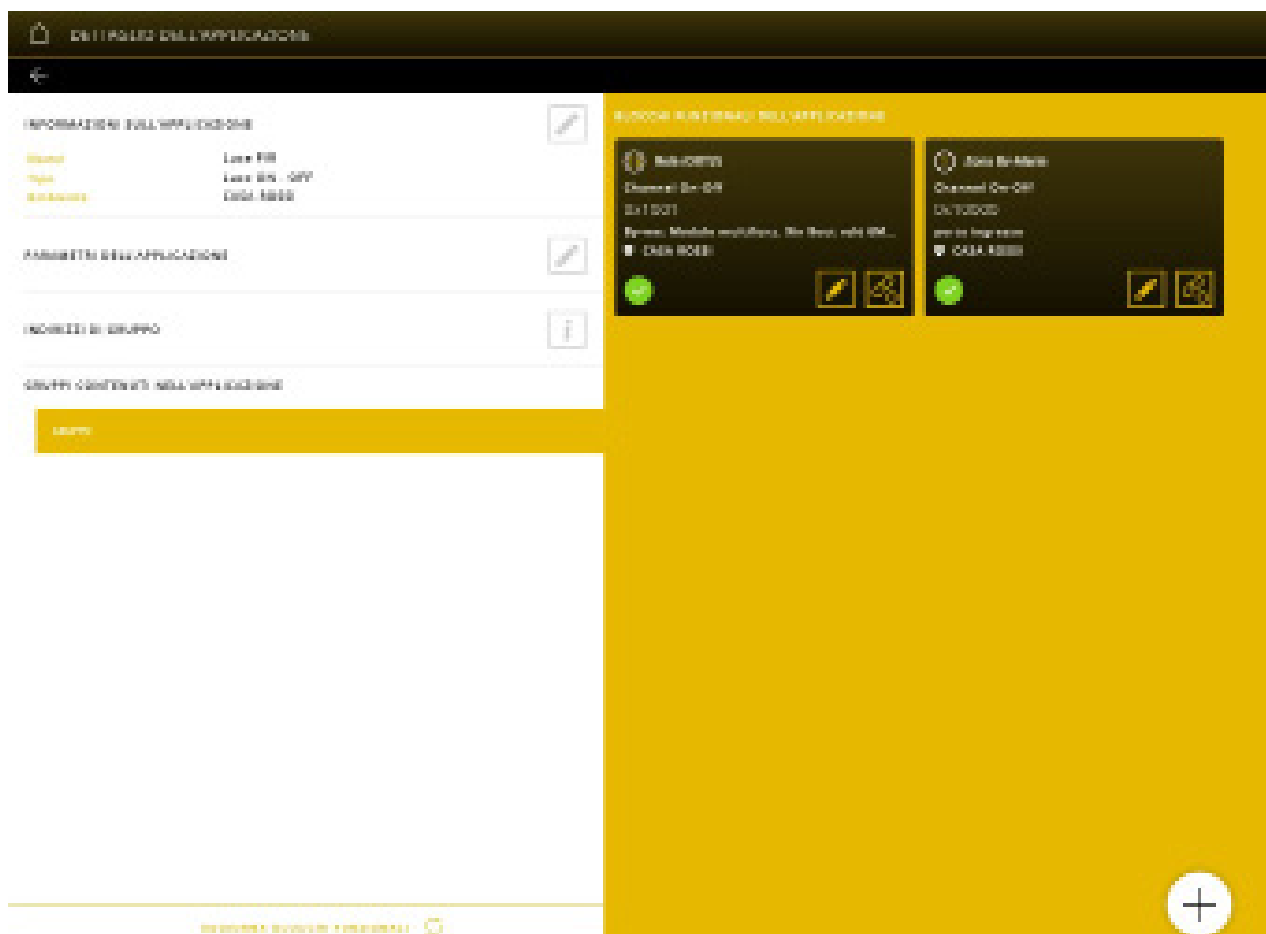

Configuration with View Pro App

Once the integration has been updated with "ENABLE/UPDATE", select "VERIFY CONFLICTS" to check the integration itself was configured correctly.

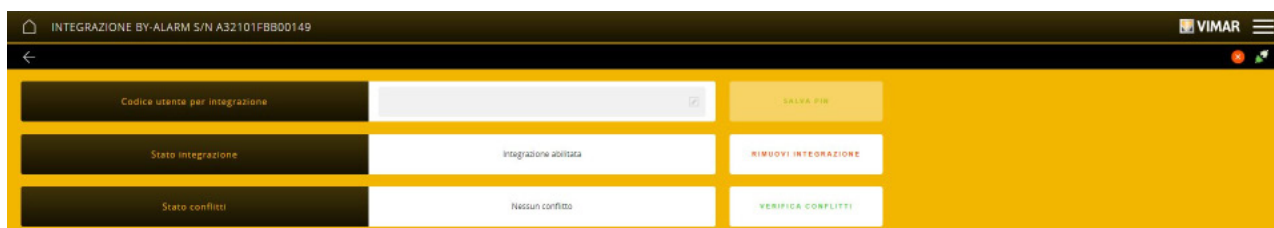

A report is then displayed containing any devices/applications on which to intervene in order to enable the integration to operate correctly (all conflicts must be eliminated otherwise the integration remains blocked).

Integration with the video door entry system is identical; select VIDEO DOOR ENTRY SYSTEM INTEGRATION DEVICES to display the page relating to the video door entry system gateway with all its devices (in this case, there is no need to enter a PIN). Perform the enabling and create the desired application by pairing the functional units of the By-me Plus devices with those of the 2F+ or IP video door entry system.

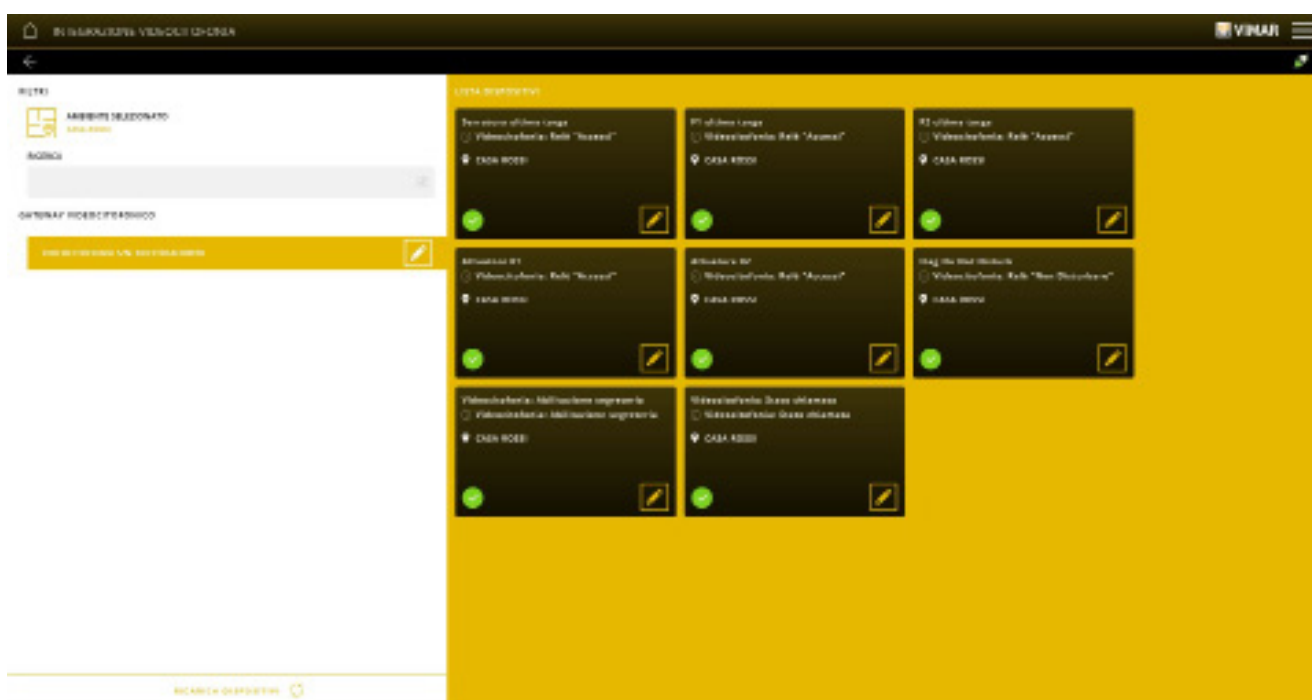

In this case too, perform a check as to the correct configuration of the integration ("VERIFY CONFLICTS") and also choose whether to silence the video door entry system call or not.



Configuration with View Pro App

4.6 Configuration of the weather station 01546.

Once the device has been enrolled, select APPLICATIONS -> SENSORS.

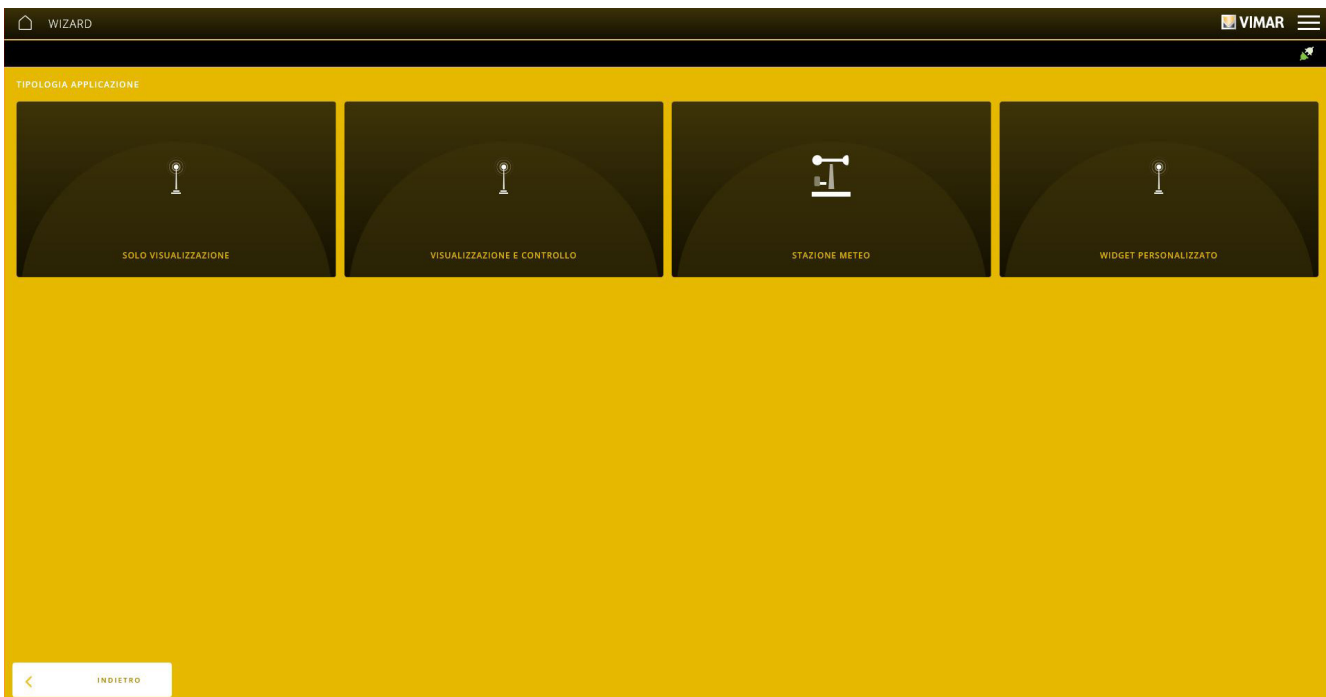

Select WEATHER STATION and use  to select the weather station to configure from the possible list.

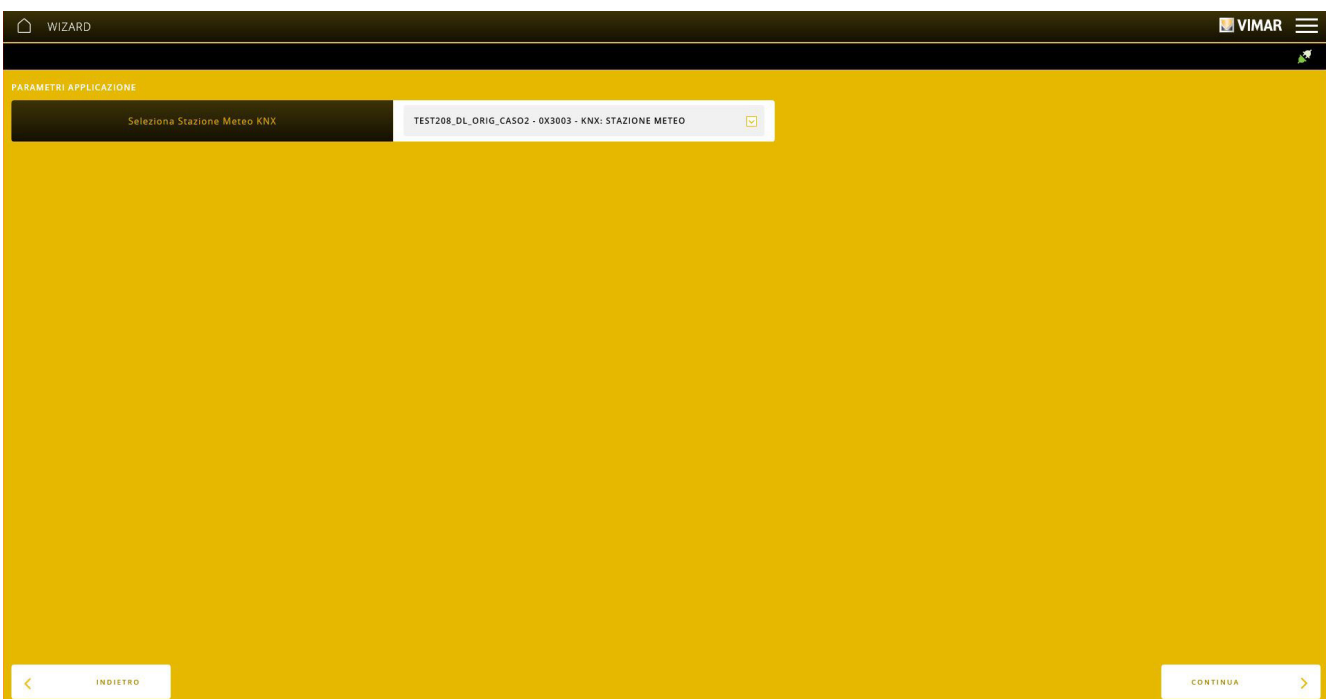

You will then be prompted to enter the name that identifies the function within the environment.

Click on "END"; the screen displayed is of the application you just created, showing the functional unit of the weather station.

Configuration with View Pro App

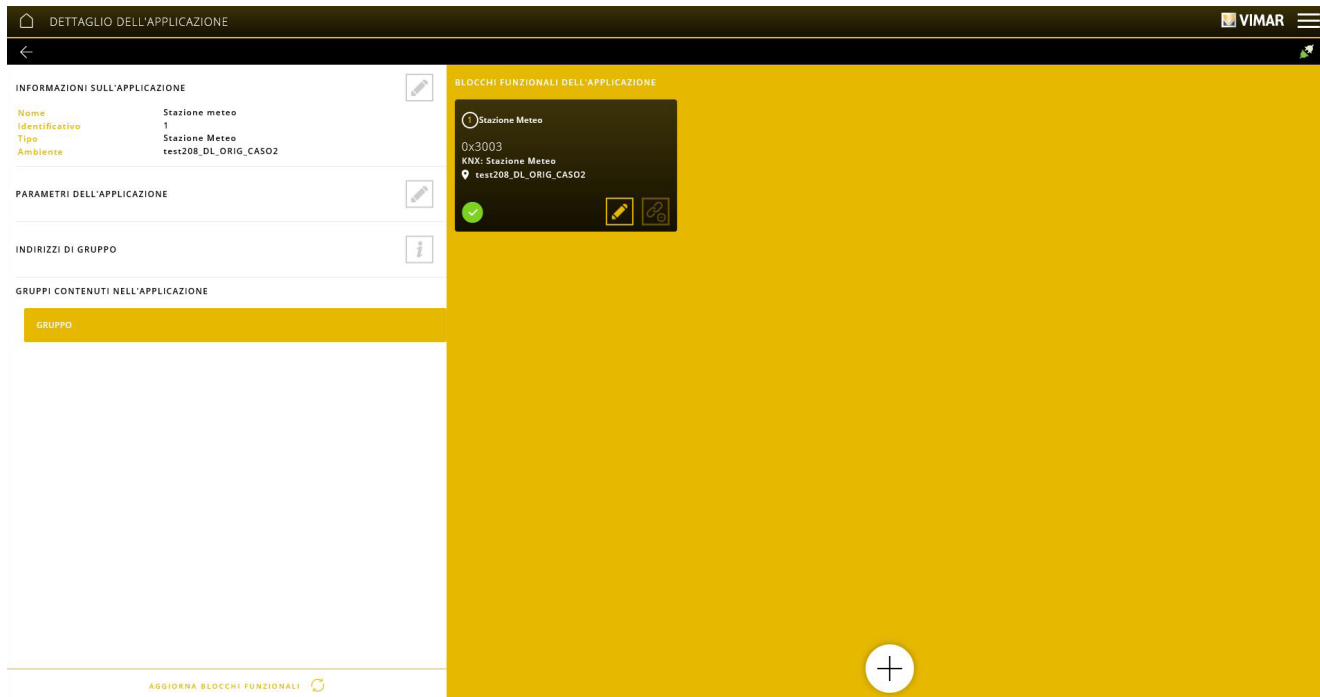

Select  for "APPLICATION PARAMETERS" to set the parameters of the weather station.

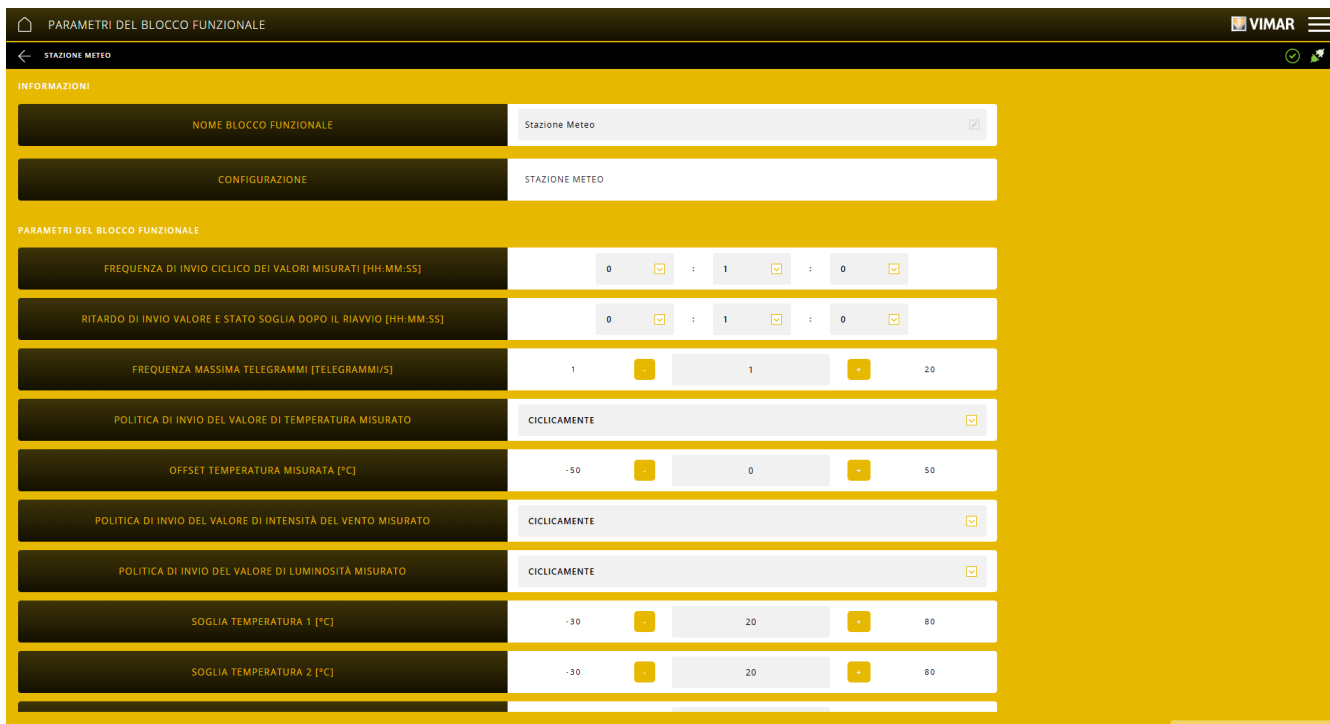

Configuration with View Pro App



Parameter Name	Current Value	Min Value	Max Value
SOGLIA TEMPERATURA 2 [°C]	-30	20	80
SOGLIA TEMPERATURA 3 [°C]	-30	20	80
SOGLIA TEMPERATURA 4 [°C]	-30	20	80
SOGLIA INTENSITÀ DEL VENTO 1 [m/s]	4	4	35
SOGLIA INTENSITÀ DEL VENTO 2 [m/s]	4	4	35
SOGLIA INTENSITÀ DEL VENTO 3 [m/s]	4	4	35
SOGLIA LUMINOSITÀ 1 [Lux]	3000	5000	20000
SOGLIA LUMINOSITÀ 2 [Lux]	3000	5000	20000
SOGLIA LUMINOSITÀ 3 [Lux]	3000	5000	20000
SOGLIA CREPUSCOLO 1 [Lux]	2	200	200
SOGLIA CREPUSCOLO 2 [Lux]	2	200	200
SOGLIA CREPUSCOLO 3 [Lux]	2	200	200



Parameter Name	Current Value	Min Value	Max Value
SOGLIA INTENSITÀ DEL VENTO 3 [m/s]	4	4	35
SOGLIA LUMINOSITÀ 1 [Lux]	3000	5000	20000
SOGLIA LUMINOSITÀ 2 [Lux]	3000	5000	20000
SOGLIA LUMINOSITÀ 3 [Lux]	3000	5000	20000
SOGLIA CREPUSCOLO 1 [Lux]	2	200	200
SOGLIA CREPUSCOLO 2 [Lux]	2	200	200
SOGLIA CREPUSCOLO 3 [Lux]	2	200	200
SOGLIA SCENARIO DI SALITA INTENSITÀ DEL VENTO [m/s]	0	65	70
SOGLIA SCENARIO DI DISCESA INTENSITÀ DEL VENTO [m/s]	0	60	70
SOGLIA SCENARIO DI SALITA LUMINOSITÀ [Lux]	0	140000	150000
SOGLIA SCENARIO DI DISCESA LUMINOSITÀ [Lux]	0	130000	150000

PARAMETRI DISPOSITIVO
NESSUN PARAMETRO DISPONIBILE

Below are the parameters and their meaning.

- Frequency of cyclic transmission of values measured:** frequency of transmission of the values measured by the sensors when the set transmission policy is cyclically or cyclically and when it changes.
 The values that it can take are: from 0:0:5 (5 seconds) to 2:59:59 (2 hours 59 minutes and 59 seconds) with 1-second steps.
 Obviously the value of this property is taken into consideration by the device if the selected transmission policy includes cyclical transmission.
- Delayed transmission of value and threshold status after restart:** delay after switching on the device for sending control messages.
 The values that it can take are: from 0:0:5 (5 seconds) to 2:59:59 (2 hours 59 minutes and 59 seconds) with 1-second steps.
- Maximum frequency of telegrams:** Maximum frequency of sending messages on the bus.
 The values that it can take are: from 1 to 20 per second.

Configuration with View Pro App

- **Measured temperature value transmission policy.**

The admitted values are the following:

- cyclically: the message is sent at a set frequency,
- when it changes: the message is sent when the value changes,
- cyclically and when it changes: the message is sent both at a set frequency and when the value changes.

- **Measured temperature offset [°C]:** calibration value of the temperature sensor.

- **Measured wind strength value transmission policy.**

The admitted values are the following:

- cyclically: the message is sent at a set frequency,
- when it changes: the message is sent when the value changes,
- cyclically and when it changes: the message is sent both at a set frequency and when the value changes.

- **Measured brightness value transmission policy.**

The admitted values are the following:

- cyclically: the message is sent at a set frequency,
- when it changes: the message is sent when the value changes,
- cyclically and when it changes: the message is sent both at a set frequency and when the value changes.

Then there are parameters for managing different thresholds.

For the temperature, four thresholds that are mutually independent are envisaged:

- **Temperature threshold 1**
- **Temperature threshold 2**
- **Temperature threshold 3**
- **Temperature threshold 4**

The values that they can take are: from -30 to 80 °C.

For instance, if the limit values set for the temperature in a warehouse were 20°, 22°, 25°, 30°, one could send the following controls:

- Threshold 1, for sending a control to switch on a fan.
- Threshold 2, for sending a control to switch on a second fan.
- Threshold 3, for sending a scenario control that involves several fans, water cooling valves and a warning light.
- Threshold 4, sends a control for the transmission of an alarm.

For wind strength, three thresholds that are mutually independent are envisaged:

- **Wind strength threshold 1**
- **Wind strength threshold 2**
- **Wind strength threshold 3**

The values that they can take are: from 4 to 35 m/s.

For the brightness, three thresholds that are mutually independent are envisaged:

- **Brightness threshold 1**
- **Brightness threshold 2**
- **Brightness threshold 3**

The values that they can take are: from 3000 to 20000 Lux.

For the dusk/dawn sensor, three thresholds that are mutually independent are envisaged:

- **Dusk/dawn sensor threshold 1**
- **Dusk/dawn sensor threshold 2**
- **Dusk/dawn sensor threshold 3**

The values that they can take are: from 2 to 200 Lux.

The following threshold parameters are provided for managing scenario activators:

- **Brightness rising scenario threshold**
- **Brightness dropping scenario threshold**

The values that they can take are: from 0 Lux to 150000 Lux.

- **Wind Strength Rising Scenario Threshold**
- **Wind Strength Dropping Scenario Threshold**

The values that they can take are: from 0 m/s to 70 m/s

Configuration with View Pro App

Once configured, the 01546 weather station is displayed on the View App and touch screens via a dedicated widget. In the View App, it is also possible to use events from this device as scenario activators.

The activators available are:

- **"Brightness above threshold"**: the scenario is activated if the currently measured brightness is higher than the value configured for the BRIGHTNESS RISING SCENARIO THRESHOLD parameter
- **"Brightness below threshold"**: the scenario is activated if the currently measured brightness is lower than the value configured for the BRIGHTNESS DROPPING SCENARIO THRESHOLD parameter
- **"Wind strength above threshold"**: the scenario is activated if the currently measured wind speed is higher than the value configured for the WIND STRENGTH RISING SCENARIO THRESHOLD parameter
- **"Wind strength below threshold"**: the scenario is activated if the currently measured wind speed is lower than the value configured for the WIND STRENGTH DROPPING SCENARIO THRESHOLD parameter
- **"It has started raining"**: the scenario is activated if rain is detected
- **"It has stopped raining"**: the scenario is activated when rain is no longer detected

Configuration with View Pro App

4.7 Configuration of actuator 01419.1 for DALI device integration.

Once the device has been enrolled, create the LIGHTS application dedicated to the management of DALI devices.

Click on  to select the environment with which to pair the application and then select LIGHTS.

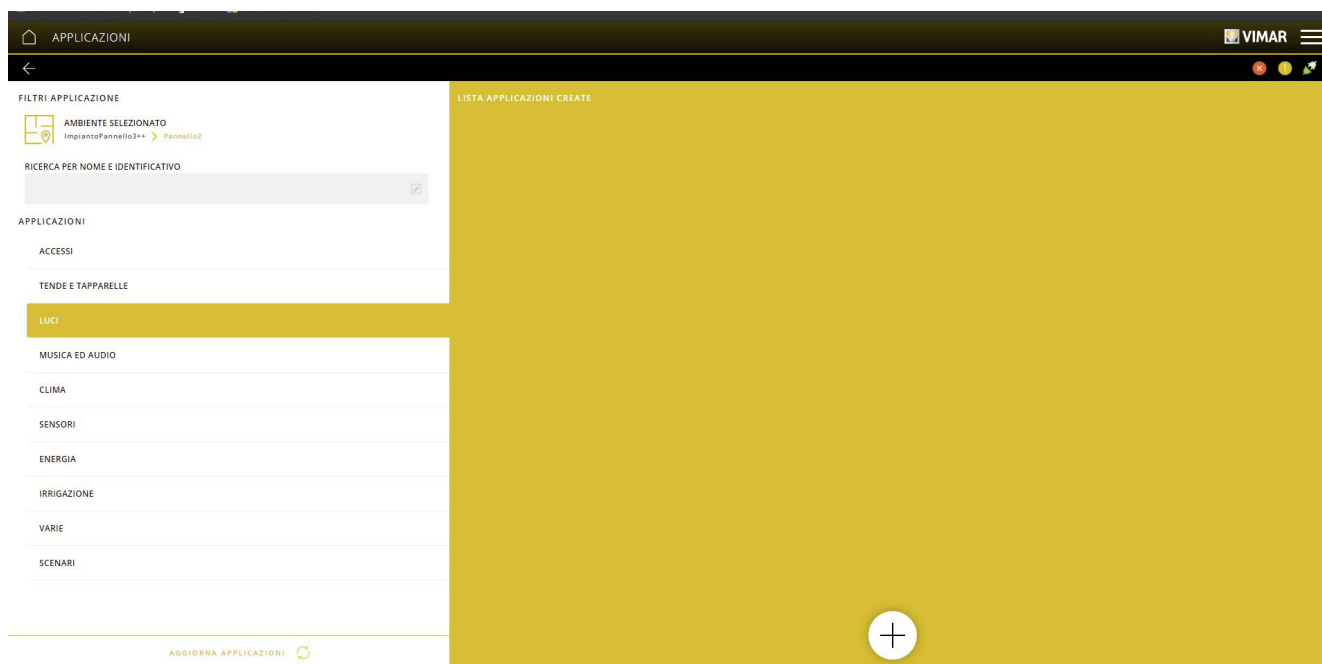

Click on  and select DALI2; then choose the type of application among those available below.

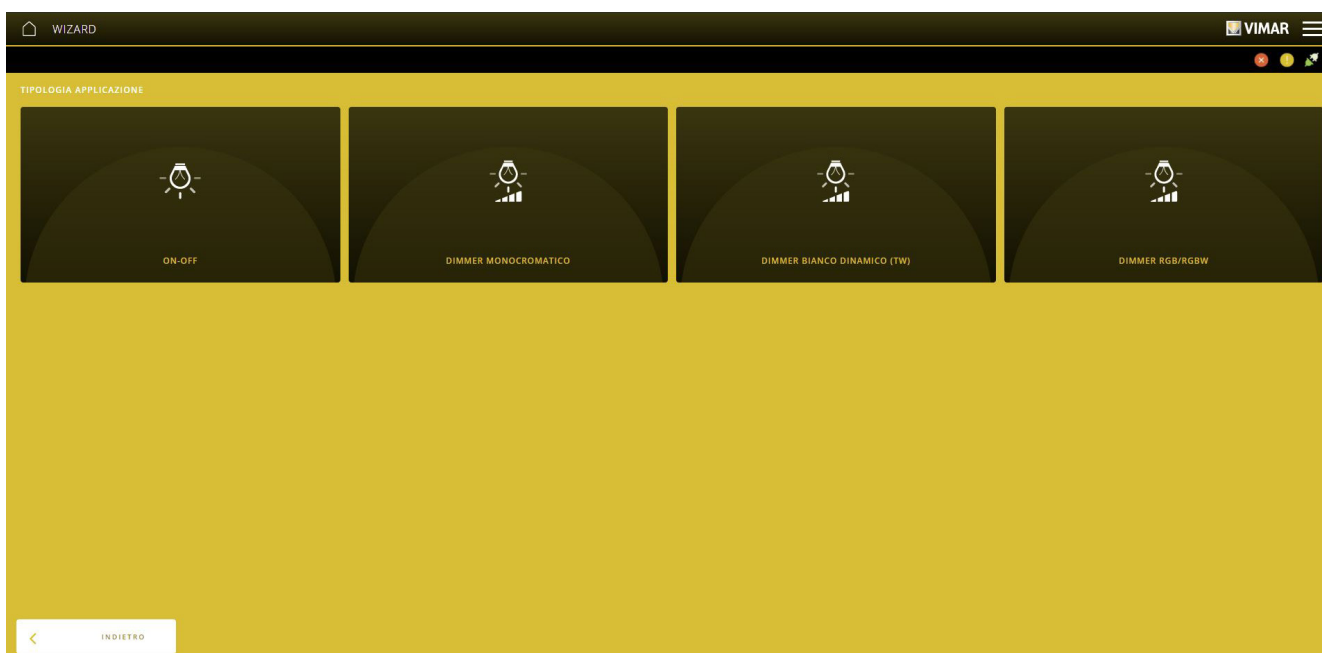

You will then be prompted to enter the name that identifies the function within the environment.

Click on "END"; the screen displayed is of the application you just created, where the functional units of the devices are then paired.

N.B. In DALI applications, actuation functional units must only be of actuators 01419.1. On the other hand, all the control functional units of By-me devices can be inserted.

In the DEVICES menu, select DALI-2 INTEGRATION and display the screen relating to actuator 01419.1 to be configured.

To proceed, the selected 01419.1 actuator must be enrolled VIA BUS; if it is only enrolled VIA CATALOGUE you will not be able to continue.

Configuration with View Pro App

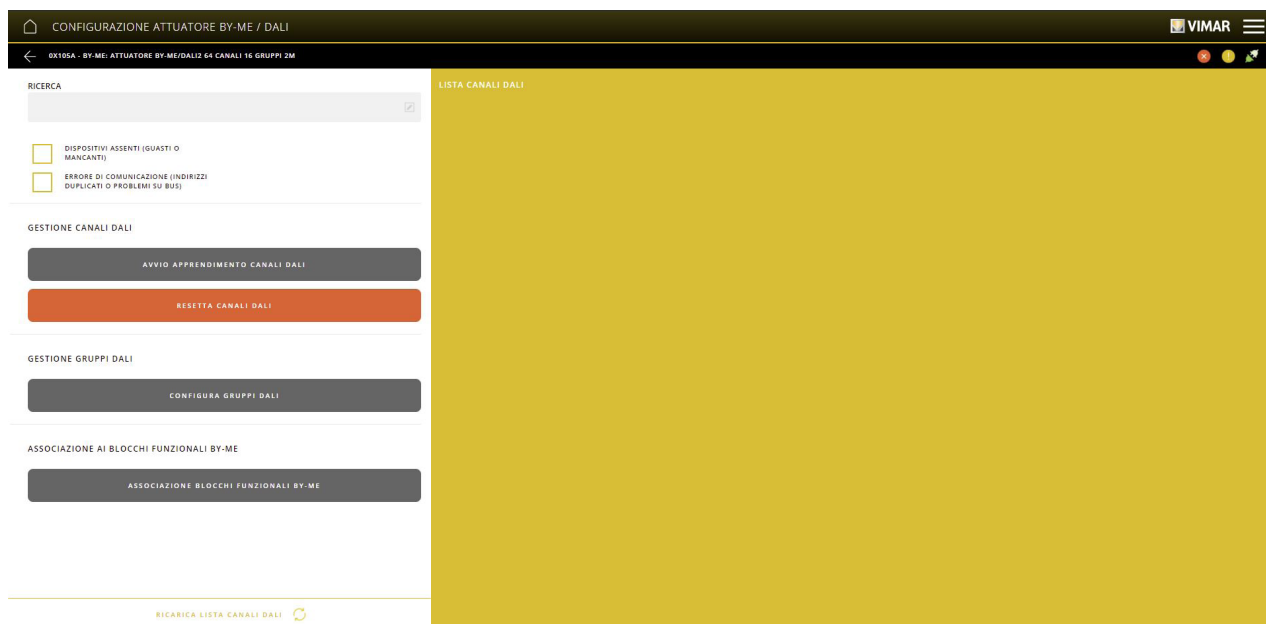

Now proceed with learning the channels; so select **AVVIO APPRENDIMENTO CANALI DALI**.

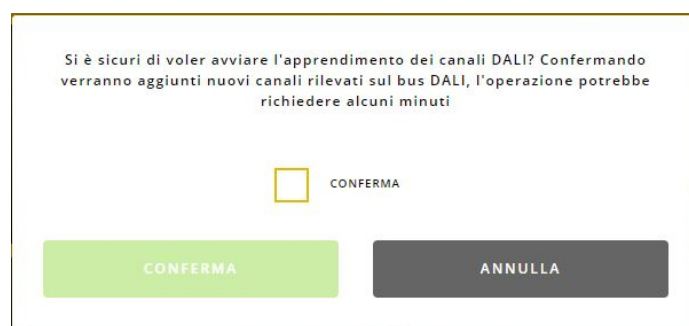

Start the operation by inserting ✓ on CONFIRM and then clicking on **CONFERMA**.



Configuration with View Pro App

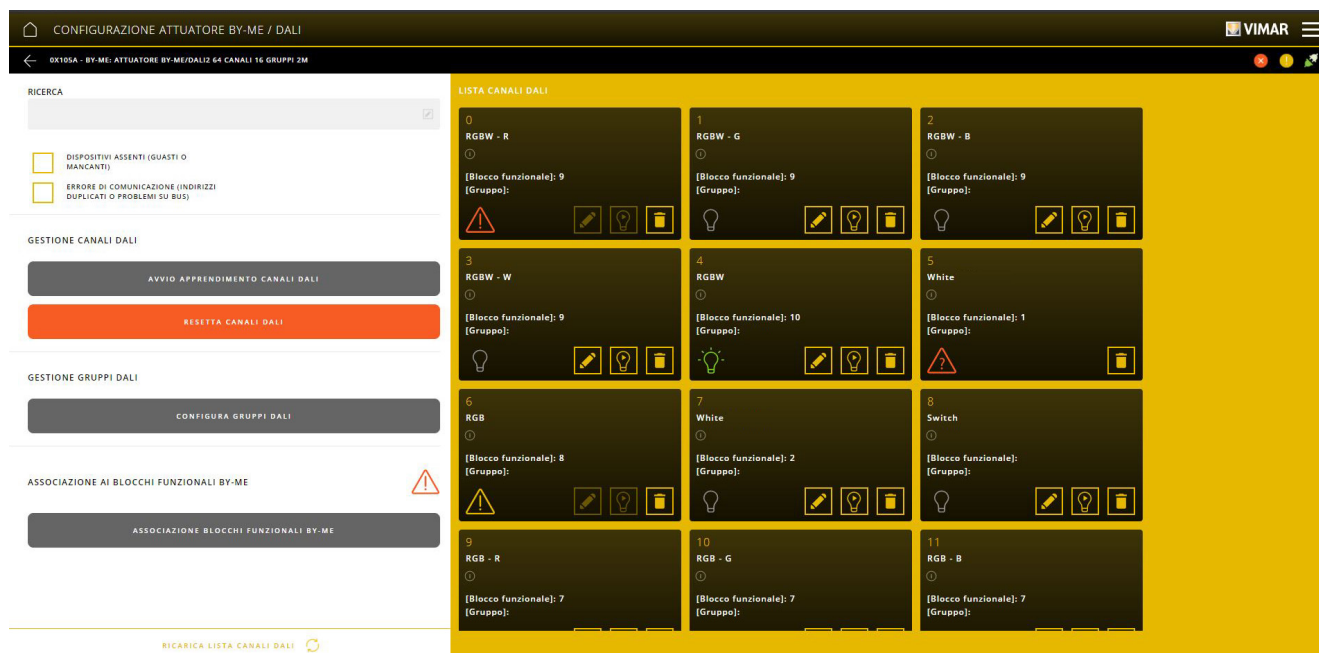

Any channel learning errors are displayed as follows:

- = communication problems on the DALI bus or devices with duplicate addresses. Then check the wiring and dimmer power supply are correct.
- = device missing. Next, perform the following checks:
 - if the device is faulty or has been removed from the system, delete it using the key;
 - make sure the wiring and power supply are correct then restart the channel learning process (if the device is detected, the error is no longer displayed).
- = device faulty or power supply not present. Then check the correct operation and the wiring of the faulty dimmer.

The “RESET DALI CHANNELS” key deletes all the channels learned, the DALI groups and the pairings between channels/DALI groups and By-me functional units. The By-me groups are not deleted however.

Once the channels have been learned, the paired DALI devices need to be identified; opposite each box that identifies the channel to be paired with the device, click on . The paired lamp will start to flash.

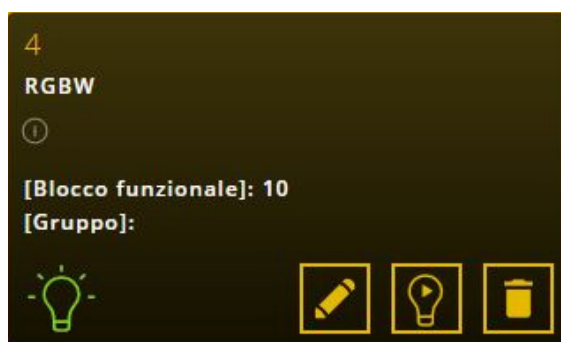

Select and assign a name to the device and a description to the channel (for instance Kitchen light). You then need to set the type of function (By-me mode selection) which must be compatible with the functional unit with which you wish to pair it.

Configuration with View Pro App

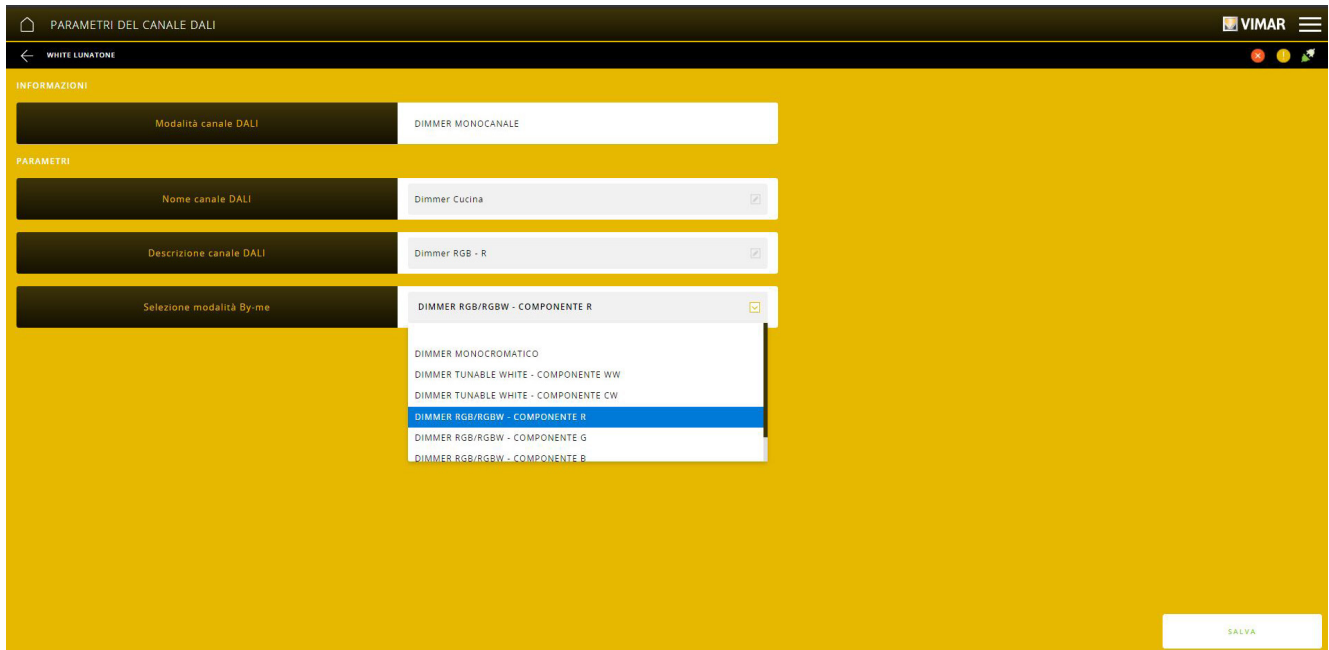

Then select "SAVE". The procedure should be performed for all the channels involved in the learning process.

In the event that several channels of the same type need to be controlled simultaneously (for instance from a single by-me push button) you need to configure the groups involved; so select "CONFIGURE DALI GROUPS" .

The screen displayed allows you to create the groups and add the respective DALI channels.

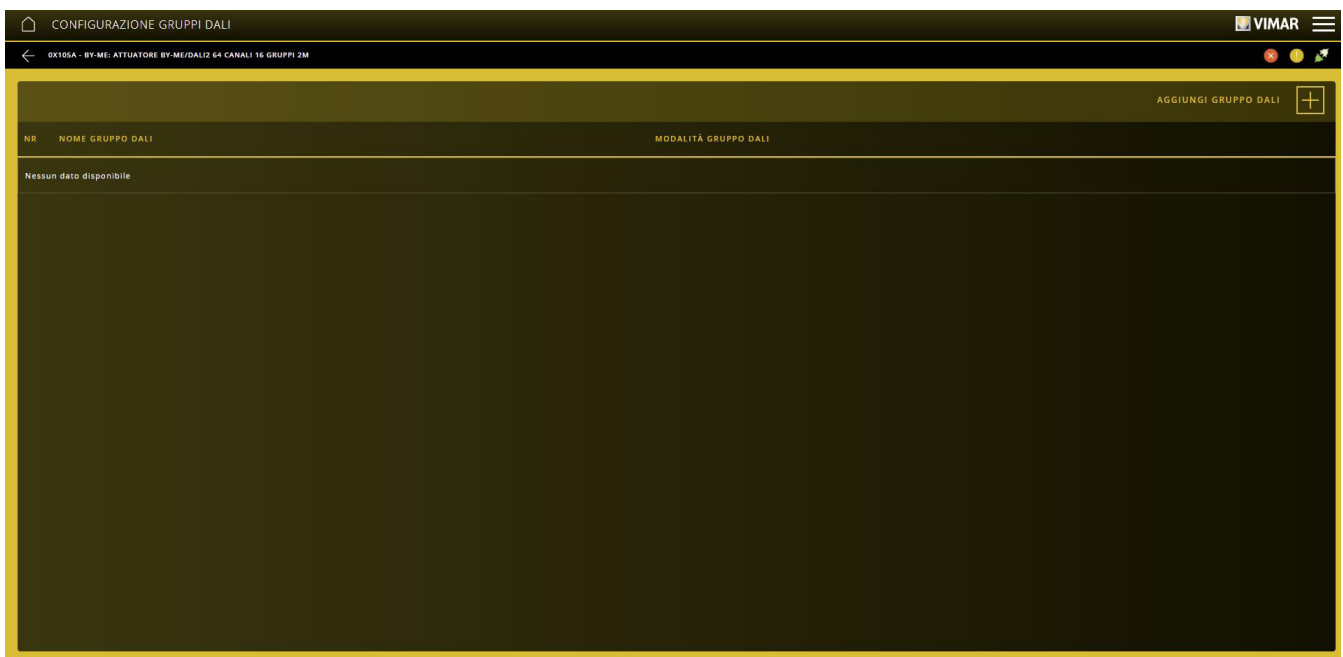

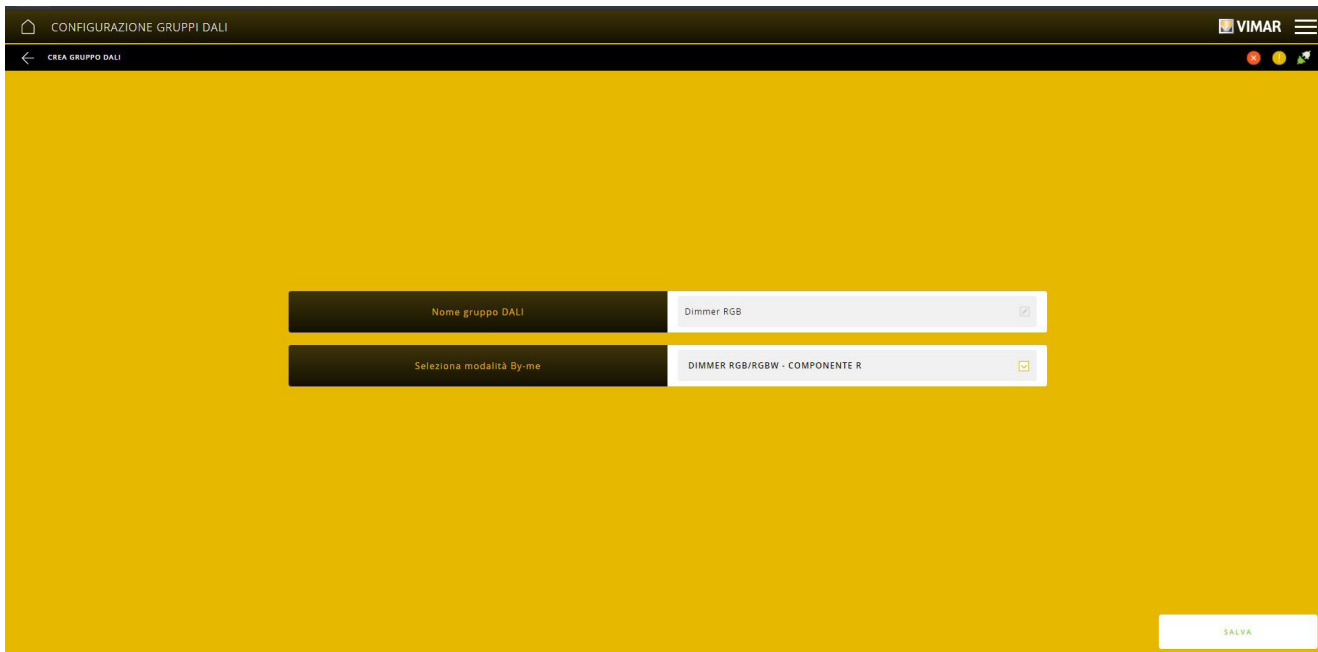

Select  ; enter the name of the group and the type of function "By-me mode selection" (which must match the one of the channels to be paired).

Configuration with View Pro App

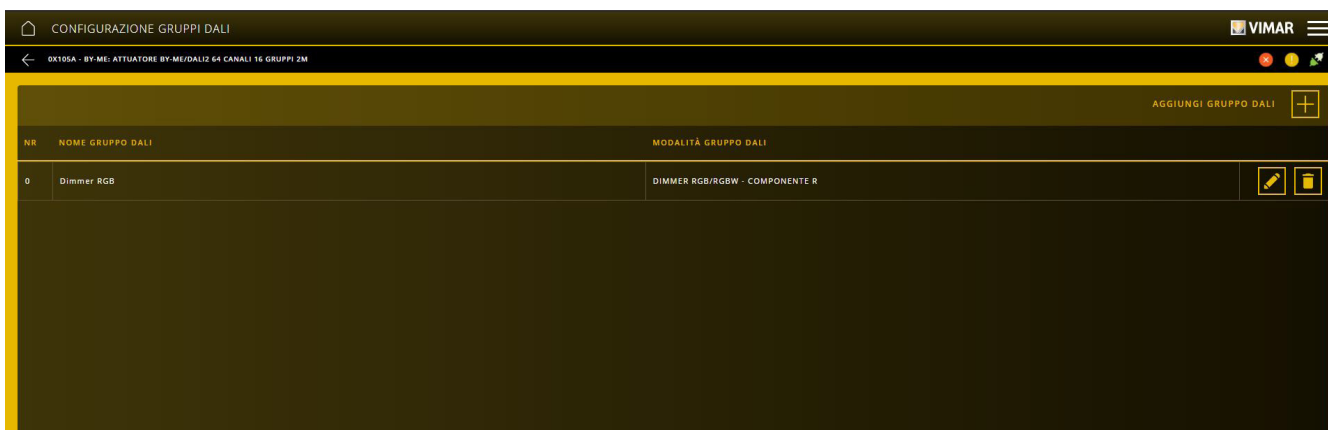

Confirm with "SAVE". The group you just created will be displayed in the configuration screen.



Select ; the screen displayed allows you to pair the channels and modify the name of the group.

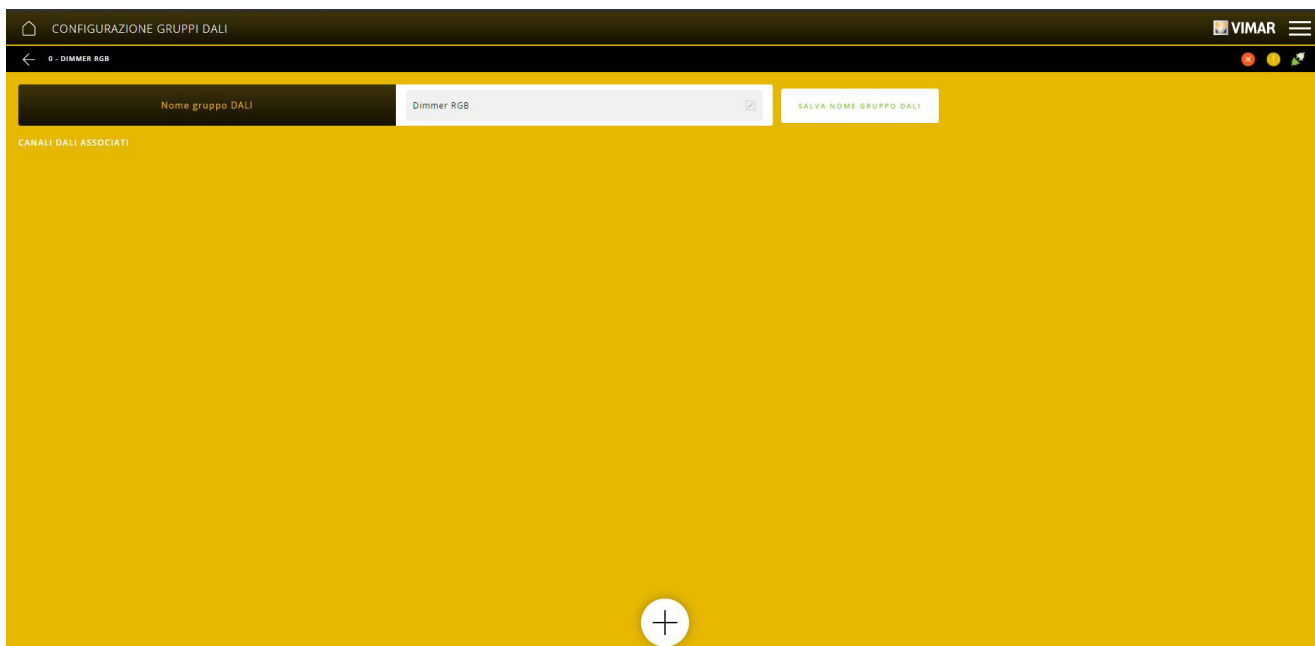

Configuration with View Pro App

Click on  ; the list of channels that can be paired with the group will be displayed.

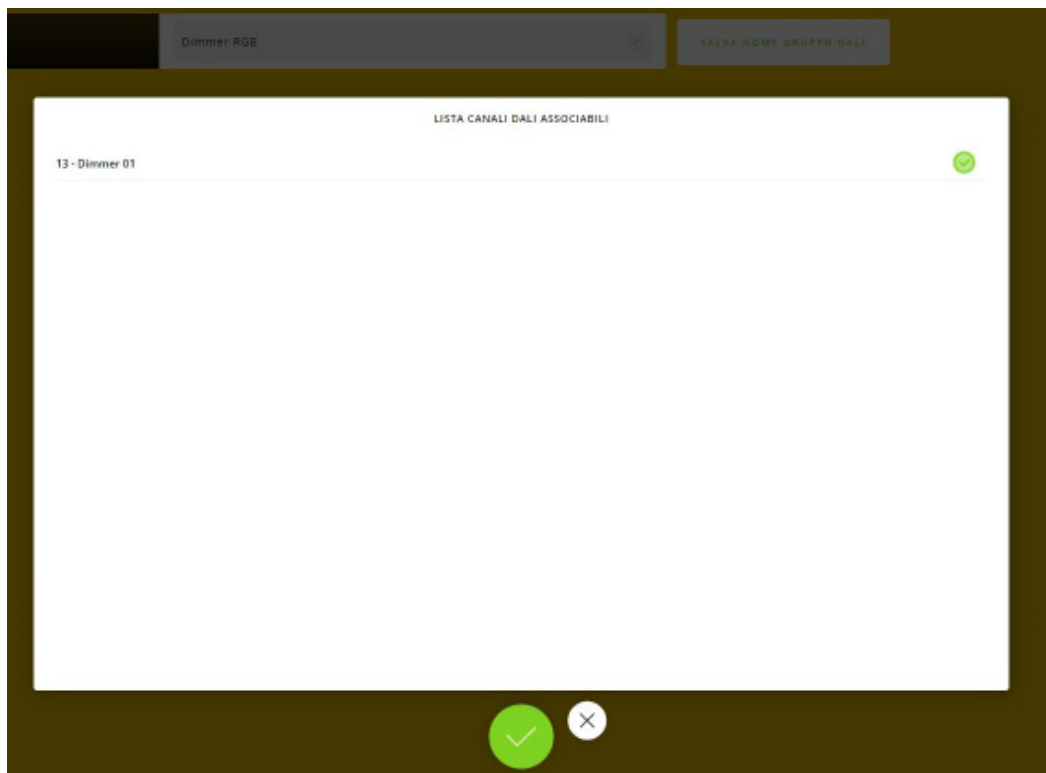

Use  to select the channels to be paired and confirm with  ; the paired channels will then be displayed as shown below.

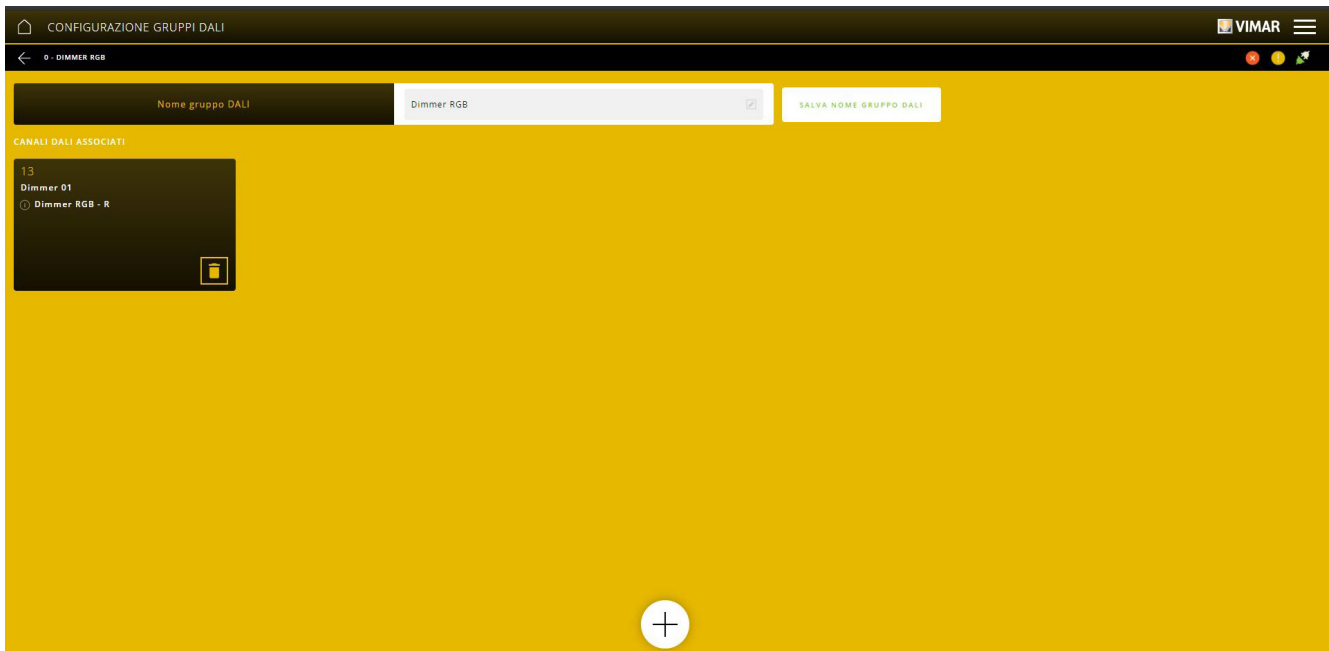

The procedure should then be performed for all the DALI groups to be configured.

The  key allows you to unpair the channel from the group in which it has been inserted.

Now proceed with the association of the By-me functional units with the DALI groups; select "BY-ME FUNCTIONAL UNIT ASSOCIATION".

The screen with the list of By-me functional units that had previously been configured in the LIGHTS application is displayed.

Configuration with View Pro App

BLOCCO FUNZIONALE	TIPO BLOCCO FUNZIONALE BY-ME
Dimmer DALI 1	DIMMER
Dimmer DALI 2	DIMMER
Dimmer DALI 3	DIMMER
Dimmer DALI 4	ON-OFF
Dimmer DALI 5	DIMMER BIANCO DINAMICO
Dimmer DALI 6	DIMMER BIANCO DINAMICO
Dimmer DALI 7	DIMMER RGB (FUNZIONAMENTO RGB)
Dimmer DALI 8	DIMMER RGB (FUNZIONAMENTO RGB)
Dimmer DALI 9	DIMMER RGBW (FUNZIONAMENTO RGBW)
Dimmer DALI 10	DIMMER RGBW (FUNZIONAMENTO RGBW)

Select  opposite the functional unit; at the first access, the App will ask whether the functional unit is DT8 (ENABLED or DISABLED).

N.B. By enabling the DT8 the selection can only be modified using the  key.



Once the DT8 has been selected (enabled or disabled) you need to define the channels that perform the various R, G, B and W components (in this example, the RGB/RGBW DIMMER had been selected).

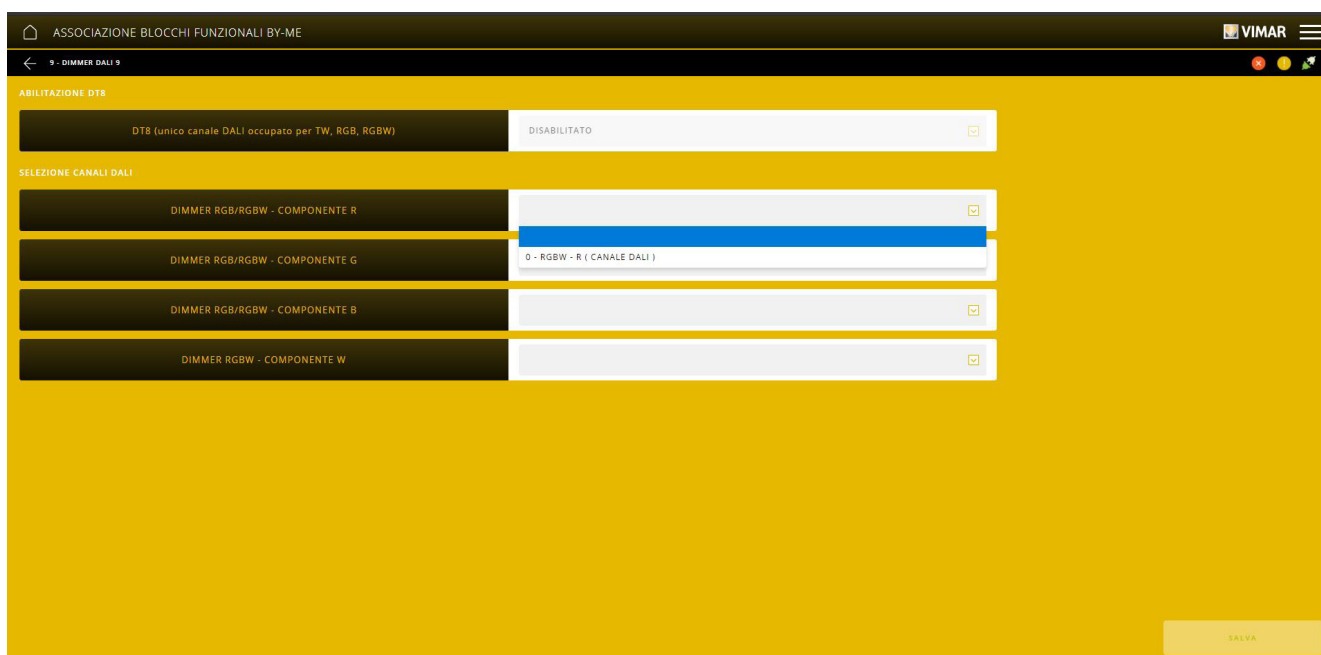

Once all the channels required by the App have been set, confirm with "SAVE". The procedure should then be performed for all the functional units to be paired.





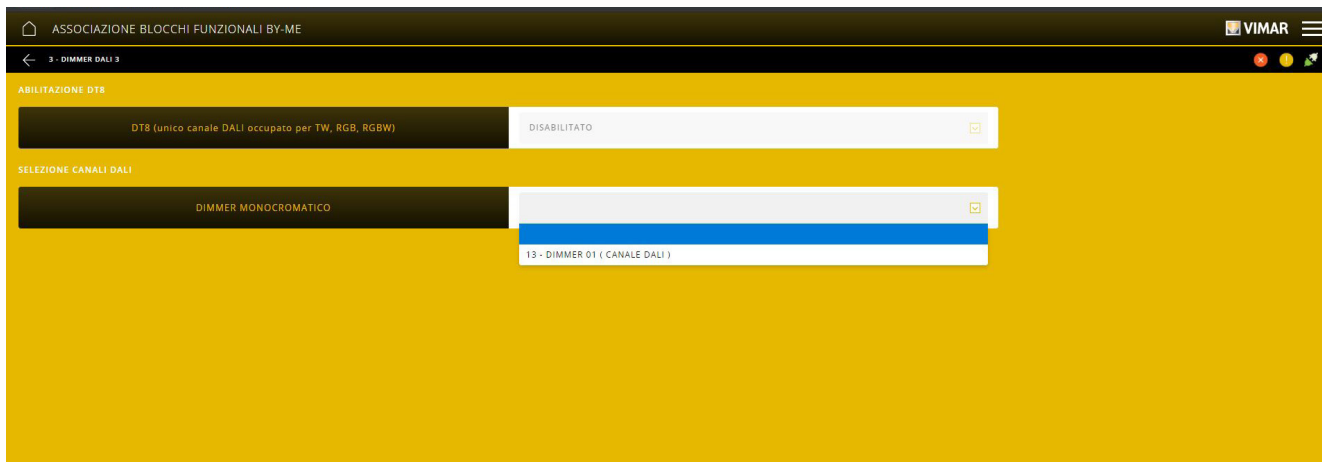



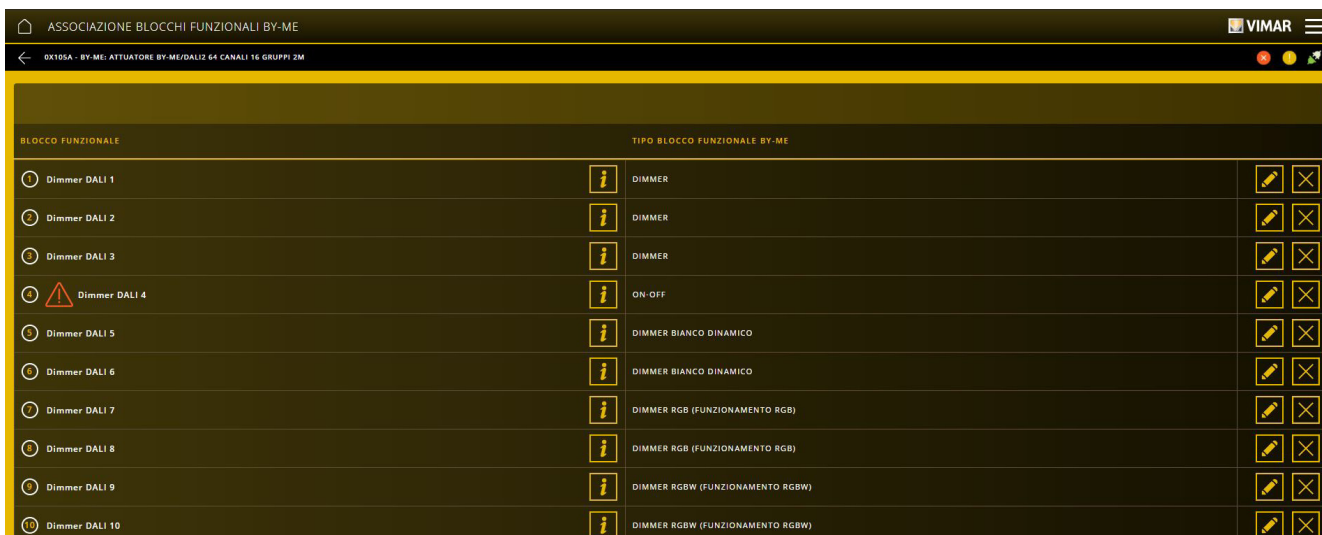





















The number of channels to be set varies according to the dimmer used (see the table entitled "TYPE OF LAMPS AND CHANNELS USED" found in the instructions sheet of art. 01419.1); for instance, if the "MONOCHROME DIMMER" has been selected, the association screen would be the following:

Configuration with View Pro App



When the association screen displayed the  symbol opposite the functional unit, this means the association of the respective channels is not complete, i.e. the association has not been completed or a paired channel has been removed. This symbol is also displayed in the detailed screen of actuator 01419.1 opposite ASSOCIATION WITH BY-ME FUNCTIONAL UNITS.



BLOCCO FUNZIONALE	TIPO BLOCCO FUNZIONALE BY-ME		
Dimmer DALI 1	DIMMER		 
Dimmer DALI 2	DIMMER		 
Dimmer DALI 3	DIMMER		 
 Dimmer DALI 4	ON-OFF		 
Dimmer DALI 5	DIMMER BIANCO DINAMICO		 
Dimmer DALI 6	DIMMER BIANCO DINAMICO		 
Dimmer DALI 7	DIMMER RGB (FUNZIONAMENTO RGB)		 
Dimmer DALI 8	DIMMER RGB (FUNZIONAMENTO RGB)		 
Dimmer DALI 9	DIMMER RGBW (FUNZIONAMENTO RGBW)		 
Dimmer DALI 10	DIMMER RGBW (FUNZIONAMENTO RGBW)		 

Then select  and complete the association with the missing channels.

The  key is designed to display the application in which the functional unit is configured.

The  key is designed to remove the associations and return the DT8 to NOT SELECTED.

IMPORTANT:

- During Maintenance, if it is necessary to replace actuator 01419.1 (see para. 4.2.1.3), following replacement, the entire configuration of the By-me functional units and the entire DALI configuration will be restored. In the event that changes have been made to the DALI system and/or the replacement operation is unsuccessful, perform the channel reset ("RESET DALI CHANNELS" key) and configure the DALI part again.
- In the event that the system was previously cloned, after the replacement, only the By-me configuration will be restored, and the DALI configuration will need to be repeated (due to the fact that the DALI system is now different from the original one).

Configuration with View Pro App

4.8 Logical programmes

Select the home automation system gateway from the list of those configured and click on "LOGICAL PROGRAMMES".

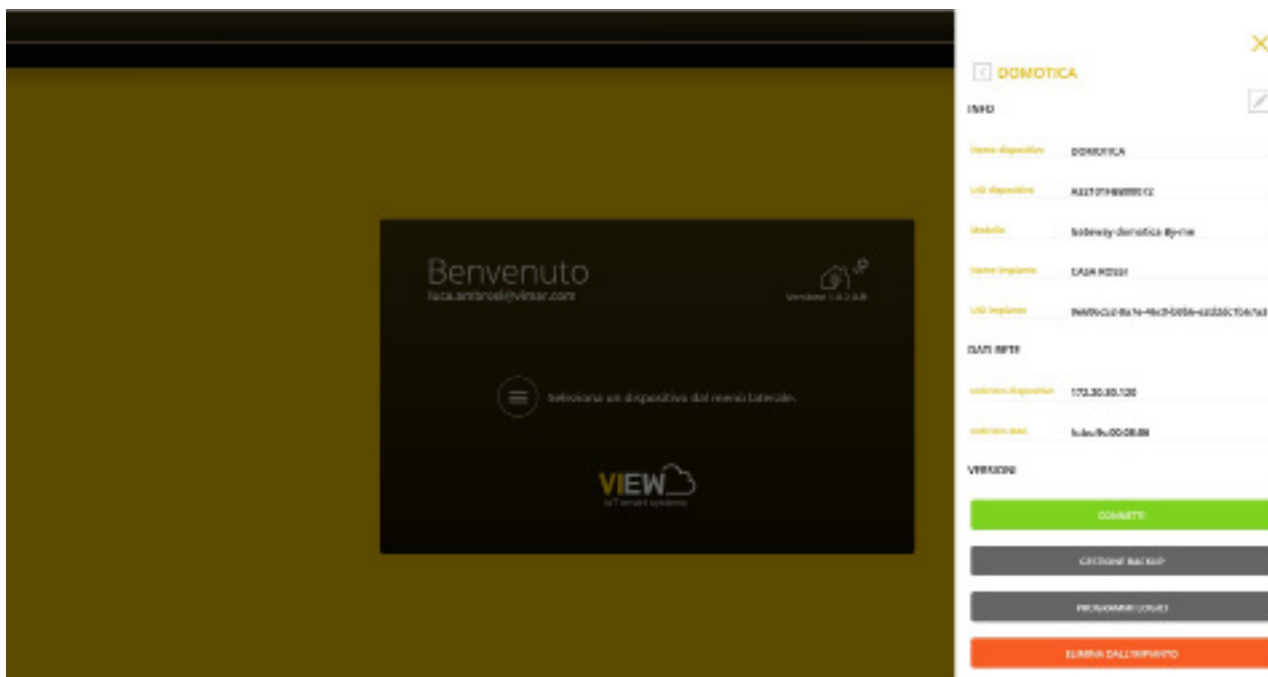

The menus displayed allow you to import, create and manage all the logical programmes to be made operational in the system.



• Select "UPDATE SYSTEM DATA" to display the following menus:

- "IMPORT DATA FROM GATEWAY" that allows you to transfer the information about the applications configured in the system from the gateway to the PC/tablet. This information includes data for all system applications, regardless of whether they contain devices enrolled VIA BUS and/or VIA CATALOGUE.
- "UPDATE SYSTEM DATA FOR EDITOR" that allows you to transfer the data from PC/tablet to Cloud.

Configuration with View Pro App

- Select "LOGICS EDITOR" to display the following menus:
 - "START EDITOR" to display the editor for the creation of logical programmes.

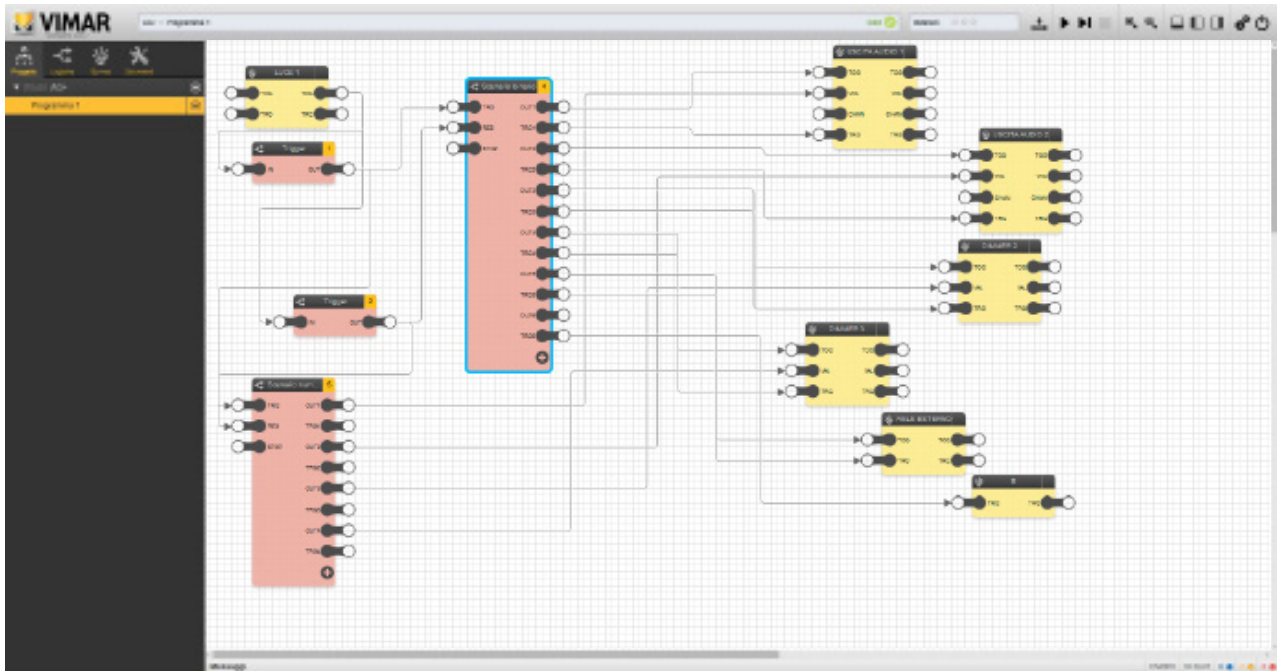

The method of creation of the programmes is the same one used for the logic unit so, for all details relating to the logical blocks and their use, please consult the Editor manual which can be downloaded from the www.vimar.com website.

Once you have created the programme, select  to perform the compilation and then exit with .

- "DOWNLOAD LOGICS PACKAGE FOR GATEWAY" that allows you to download onto PC/tablet the programmes created with the gateway editor.
 - "DOWNLOAD LOGICS PACKAGE FOR 01468" that allows you to download onto PC/tablet the programmes created with the editor of the logic unit 01486.
- Select "LOGICS MANAGEMENT ON GATEWAY" to display the following menus:
 - "DOWNLOAD LOGICS PACKAGES ON GATEWAY" that allows you to download the programmes from PC/tablet onto the gateway.
 - "DELETE LOGICS ON GATEWAY" that allows you to delete the programmes on the gateway.
 - "VERIFY CONFLICTS" that allows you to verify whether logics exist that share the same resources as other more complex logics which could therefore cause malfunctioning.

If it is necessary to use the logic unit art. 01468, to integrate it in the system, you need to create a dedicated application in the VARIOUS category; proceed as follows:

- Enrol logic unit 01468 using the procedure illustrated in para. 4.2.1.1
- Select the VARIOUS application type and select LOGIC UNIT.

The logic unit can now be used to activate the logical programmes configured (or to be configured) via the Editor.

Configuration with View Pro App

4.9 Gateway management

From the main screen, click on BY-ME GATEWAY; the following screen is displayed:

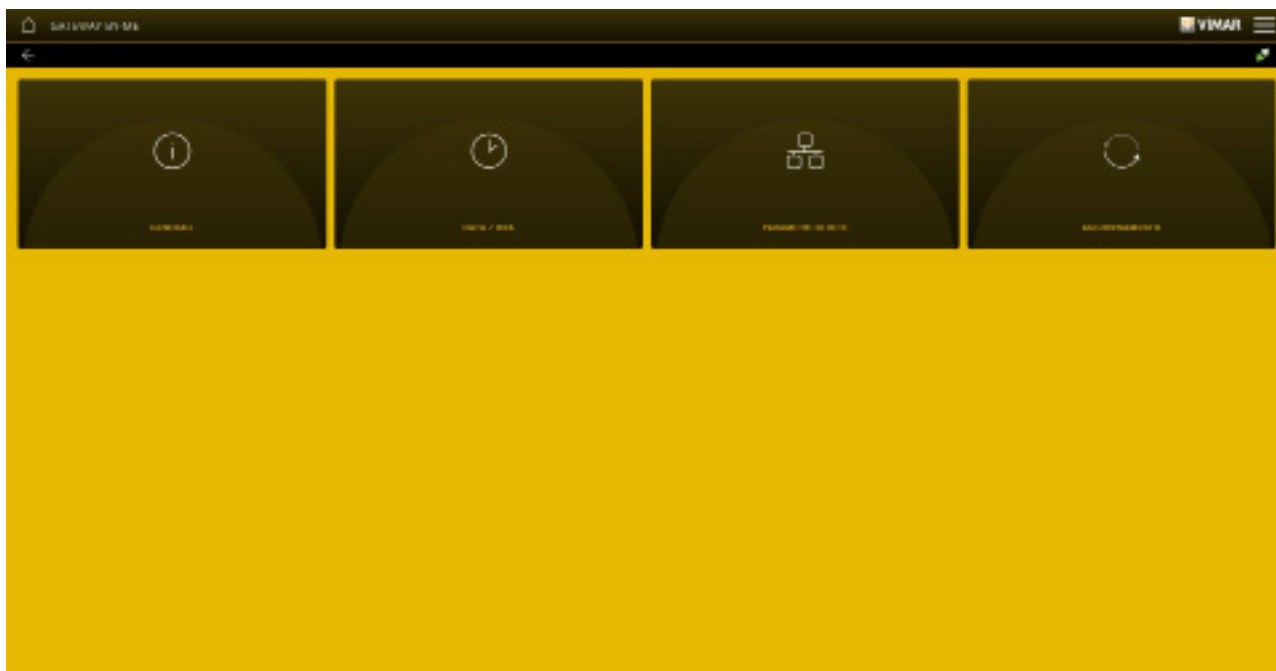

- The GENERAL menu displays all the data relating to the gateway used including the hardware and firmware versions of the device and the total and partial hours of use.
- The DATE/TIME menu is used to:
 - display the system date and time (together with the time zone used);
 - set the latitude/longitude values required by the gateway for the logic programmes functions;
 - enable/disable the automatic management of the day/night data by the gateway. When the flag is enabled, the gateway distributes the data on the bus as it changes; if the flag is instead disabled, the gateway displays a unit in the logic programmes editor to manage the data from the programme and/or from KNX integrations.
N.B.: If programmes created with the logic programme Editor are used, a system data update procedure must be performed every time this parameter is modified. For full details, see para. 4.8.
- The NETWORK PARAMETERS menu allows you to display the data that identify the device within the network.

All the data are entered/modified with the  button and then confirmed with "SAVE".

- Using the UPDATE menu, the gateway checks for the presence of new fw/sw versions and downloads them directly from the Internet; to make the update, select "UPDATE" (the option is only displayed if a new update is available).

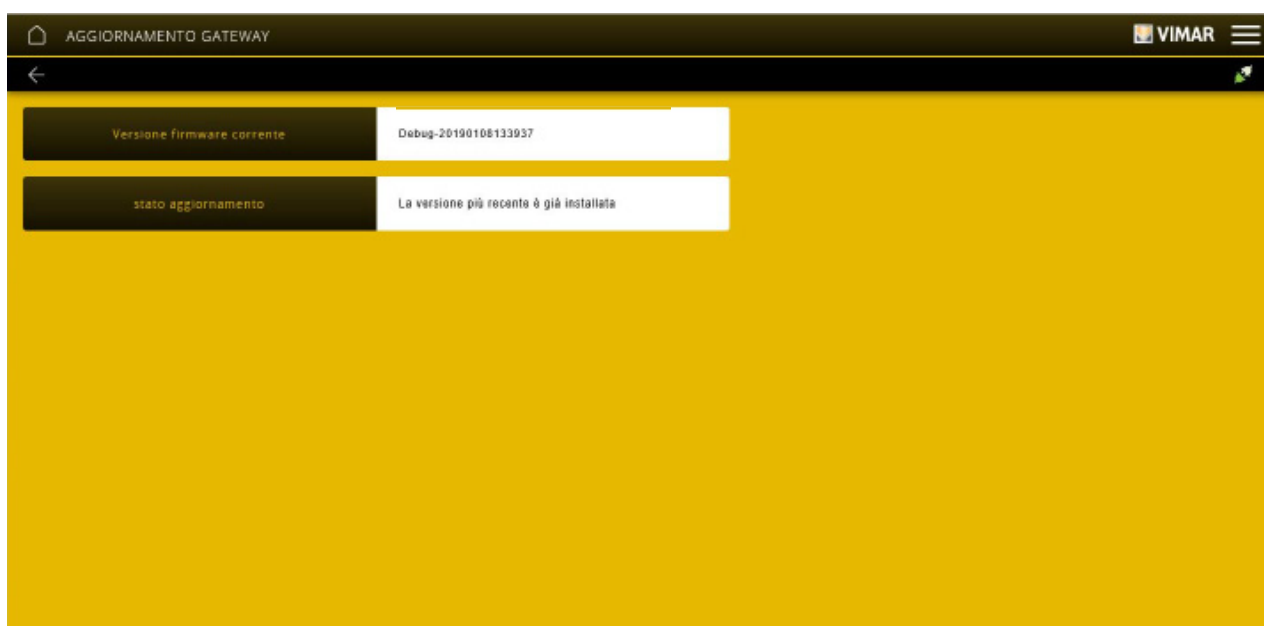

Configuration with View Pro App

4.10 By-me Plus home automation system management

From the main screen, click on BY-ME SYSTEM; the following screen is displayed:

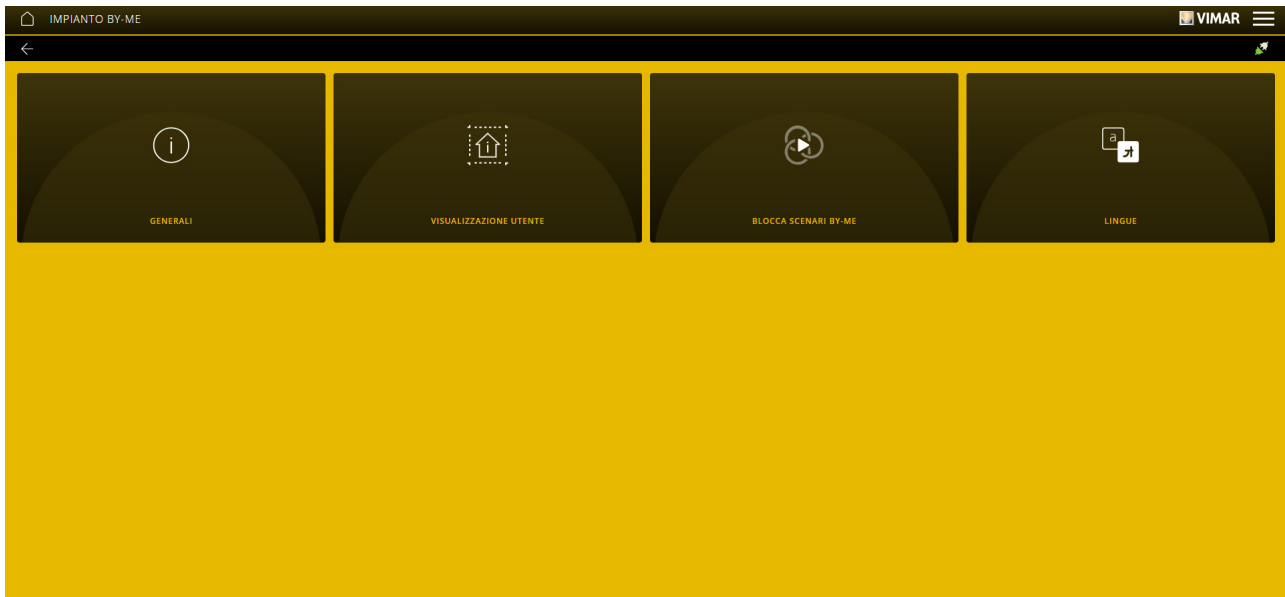

Click on GENERAL to display:

- The status information, such as the gateway connection status to the By-me bus, its address, the Area and Line number, the group offset and the maximum group address.
- The statistical data, such as the number of environments, applications and devices configured. The current weight value of the By-me devices configured with respect to the maximum value supported by the gateway is also displayed.
- The consumption data of the By-me devices, divided up by line.

Click on USER DISPLAY to display the system data for the insertion of the description and the option to conceal any applications from the user.

The system data can be modified using the  button and confirmed with "SAVE".

Click on LOCK BY-ME SCENARIOS to display the list of scenarios currently defined in the system; you can set their locking upon modification from the View App.

- The LANGUAGES option allows you to convert and modify in the desired language the current names assigned to the environments, applications, etc. that identify the system (obviously, only the data that can be customised).

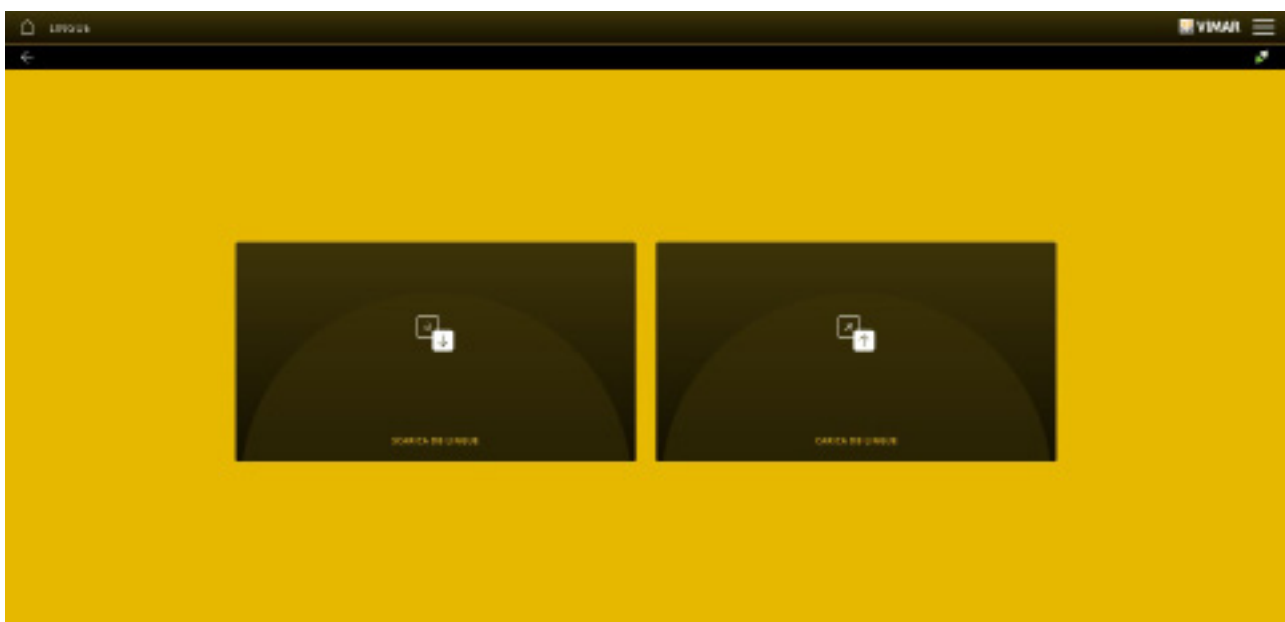

- Use "DOWNLOAD LANGUAGE DB" to create a .json file allowing you to modify the names in the various languages so that later, once the updated file has been reloaded, every element in the system is identified with the name assigned. This allows you to modify the names in one go without entering the menus and renaming every single element.
- Use "UPLOAD LANGUAGE DB" to select the updated .json file and upload it to the system, thus displaying the new names that identify the various elements.

Configuration with View Pro App

4.10.1 Hide Applications.

Use the procedure below to make certain applications created non visible to the View App (for both administrator users and non) and to the touch screens, so that they are not displayed on these devices.

1. From the list of applications created, select the one you wish to hide.
2. Select  for APPLICATION PARAMETERS.
3. Select YES for "APPLICATION HIDDEN ON USER INTERFACE".

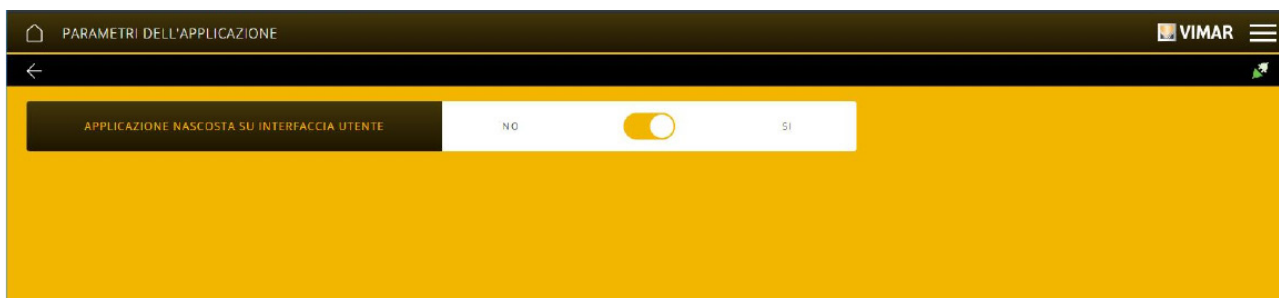

4. Repeat the procedure for all the applications you want to hide.
5. Select USER DISPLAY.

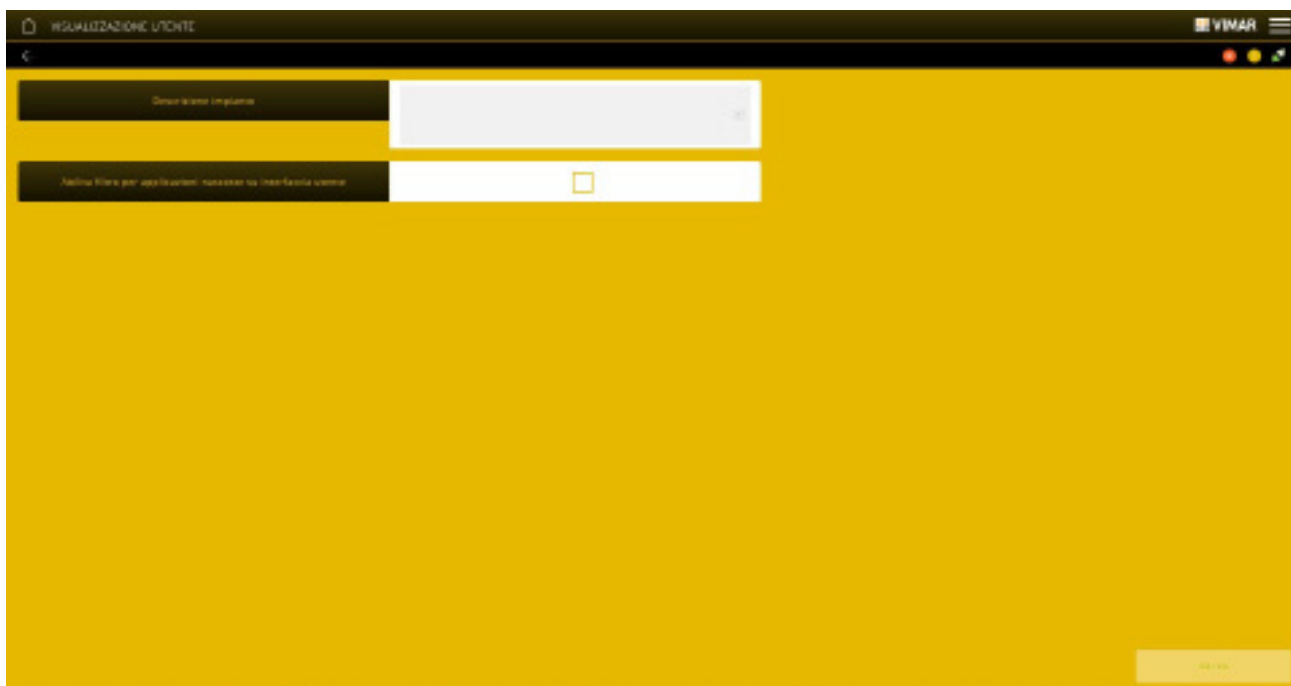

6. In "Enable filter for hidden applications on user interface" enter  and confirm with "SAVE". The applications selected previously will therefore not be displayed in the View App and in the touch screens of the end customer.

NOTE: Any scenarios containing at least one application where the APPLICATION HIDDEN ON USER INTERFACE parameter has been set will be 'locked'; this means they cannot be modified via the View App. For further details see paragraph 4.10.2.

Configuration with View Pro App

4.10.2 Locked scenarios

Scenarios are created, modified and deleted via the View App by the end-user. A scenario is defined as 'locked' if it cannot be modified or deleted, allowing it to be recalled only. This function can be used to create "technical" scenarios or those that the installer does not wish the end-user to modify.

NOTE: The "locked" scenario concept does not apply to the Cloud logic programme editor, where it remains possible to modify these scenarios. For further details, please refer to the Editor manual.

By clicking on BY-ME SYSTEM then LOCK BY-ME SCENARIOS, you can access the scenario lock management section; the following information is displayed for each scenario:

- Name associated with the scenario.
- Environment in which the scenario is defined.
- Number of hidden applications contained in the scenario.
- Enable lock.

If the "Enable lock" option is selected and/or if the scenario contains at least one hidden application, the scenario will appear as "locked" on the View App and touch screens (for further details, please refer to paragraph 4.10.1).

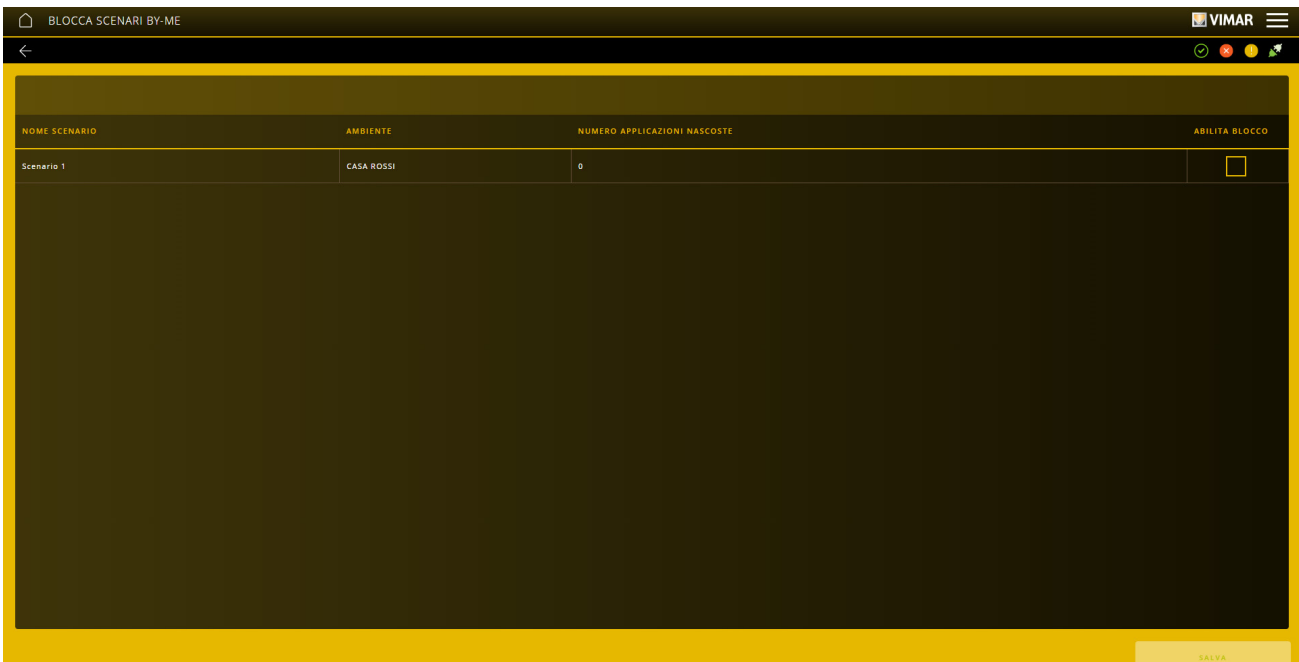

The screenshot shows the 'BLOCCA SCENARI BY-ME' screen in the View Pro App. The interface features a dark theme with yellow accents. At the top, there is a title bar with a home icon, the text 'BLOCCA SCENARI BY-ME', the VIMAR logo, and a menu icon. Below the title bar is a navigation bar with a back arrow and three status icons. The main content area displays a table with the following columns: 'NOME SCENARIO', 'AMBIENTE', 'NUMERO APPLICAZIONI NASCOSTE', and 'ABILITA BLOCCO'. A single row is visible with the following data: 'Scenario 1', 'CASA ROSSI', '0', and a yellow square icon. At the bottom right, there is a yellow button labeled 'SALVA'.

NOME SCENARIO	AMBIENTE	NUMERO APPLICAZIONI NASCOSTE	ABILITA BLOCCO
Scenario 1	CASA ROSSI	0	<input type="checkbox"/>

Configuration with View Pro App

4.11 Maintenance.

From the main screen, click on MAINTENANCE; the following screen is displayed:

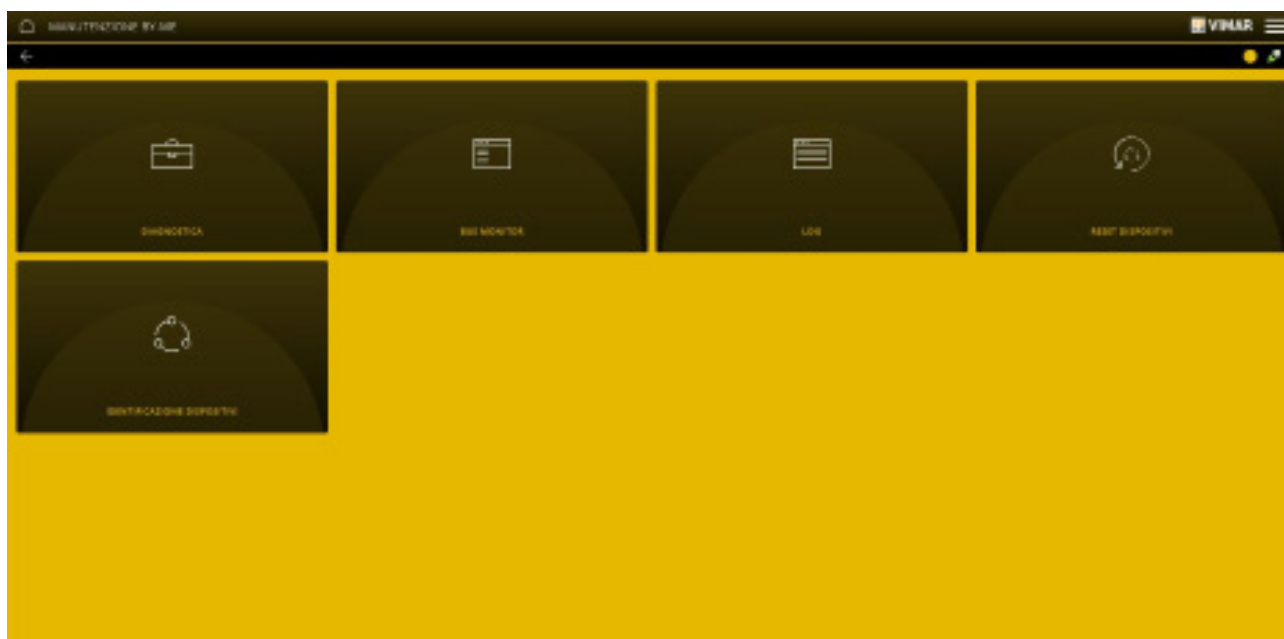

- Click on DIAGNOSTICS to perform diagnostics on the individual device (which can be selected by entering the group address) or of the entire system.

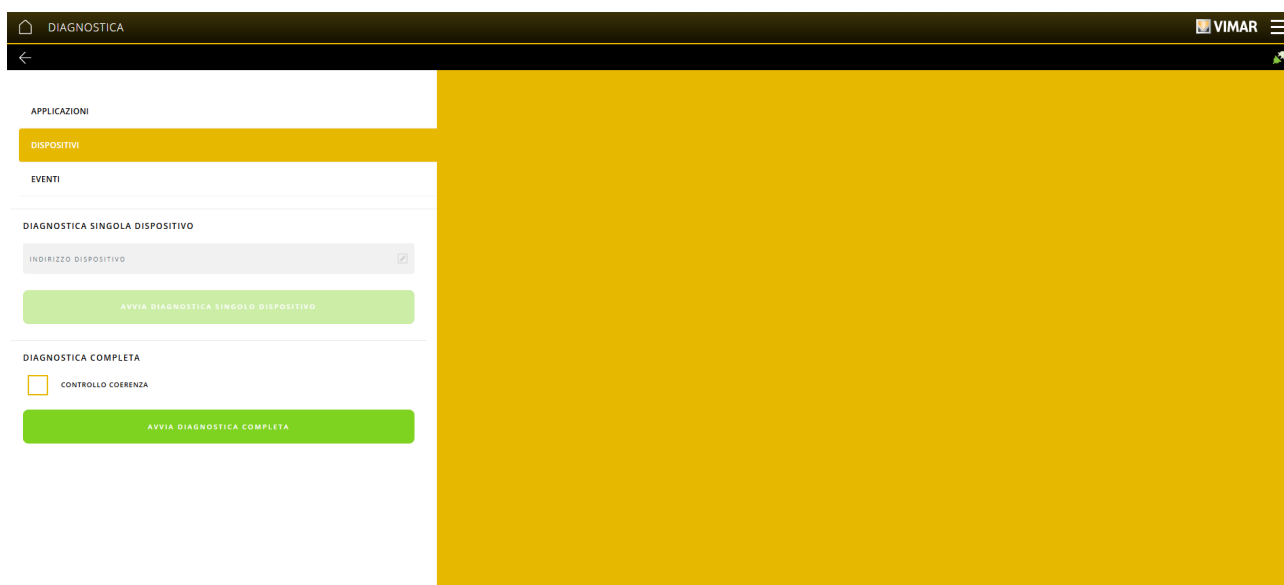

Diagnostics is only performed on By-me devices enrolled VIA BUS (KNX devices, weather station, etc. are excluded, as are all By-me devices enrolled VIA CATALOGUE) and is designed to verify whether the data present on the various devices correspond with those set in the applications (comparing the configuration of the devices present on the bus with the contents of the database).

At the end, the outcome of the operation is displayed, along with any feedback and the devices involved, identified with the symbol of the faulty device (). Please also pay attention to any configuration error notifications on the devices; in such cases, proceed with the system realignment procedure. For further details see paragraph 4.2.1.4 Select APPLICATIONS to display the list of applications containing one or more faulty devices.

Select EVENTS to display any errors diagnosed on the devices; for instance:

DATA	INDIRIZZO FISICO	NOME DISPOSITIVO	EVENTO
5 febbraio 2020 11:36:12.000	0x1A02	By-me: Modulo 3in 3out LED	Il dispositivo By-me non risponde

Enable CONSISTENCY CHECK and the system checks that the configuration data stored on every device match those stored in the home automation system gateway.

Configuration with View Pro App

- The BUS MONITOR option allows you to view the data that transit on the By-me Bus to monitor their activity and analyse particular device configuration conditions. This function also makes it possible to solve any problems found during a diagnostics scan and the correction can be made by updating the configuration of the devices starting with the data contained in the database.

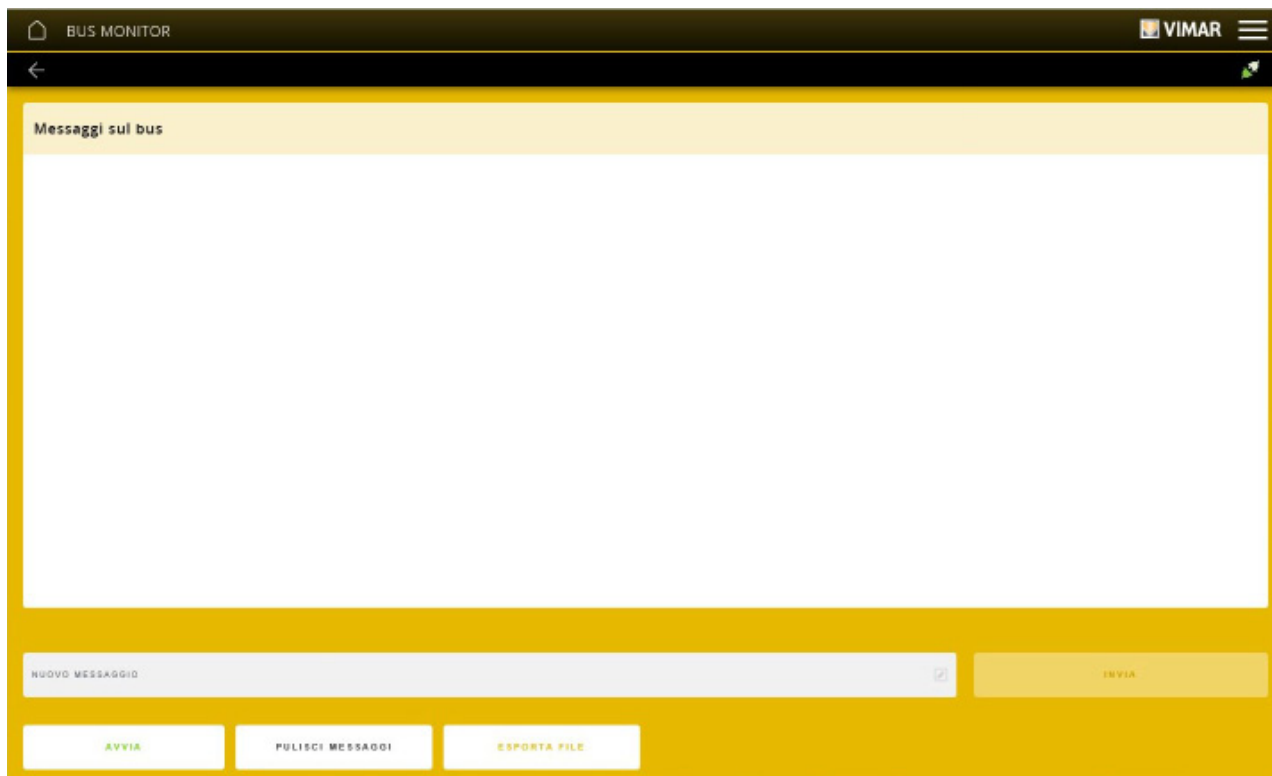

To save the data displayed click on "START".

To export the data saved to a file click on "EXPORT FILE".

To delete all the messages displayed in the main space, in other words those read directly by the bus, click on "CLEAR MESSAGES".

Sending messages over the Bus

This option is used to send messages over the bus in order to check the correct operation of the devices or of the configurations made.

The message to be sent over the bus, in hex notation, consists of the following three parts:

- the fixed field BC10AB;
- the group address of the specific DPT within the recipient application of the message (always remove the 0x prefix);
- the hex encoding of the specific function to be carried out.

The message should be inserted in the "NEW MESSAGE" space and then select "SEND".

The main functions are now illustrated, divided up by type, along with the related instructions on how to compose the associated message.

LIGHTS AND ROLLER SHUTTERS MANAGEMENT

• ON/OFF for relay

Function	Hex message		
	Fixed field	DPT	Function encoding
ON	BC10AB	DPTx_OnOff address	E10081
OFF			E10080

• Luminous intensity control for dimmer

Function	Hex message		
	Fixed field	DPT	Function encoding
Brightness at 25%	BC10AB	DPTx_Brightness address	E2008040
Brightness at 50%			E2008080
Brightness at 75%			E20080C0
Brightness at 100%			E20080FF

Configuration with View Pro App

- *Roller shutter up/down/stop*

Hex message			
Function	Fixed field	DPT	Function encoding
All DOWN	BC10AB	DPTx_UpDown address	E10081
All UP			E10080
STOP (with roller shutter in motion)		DPTx_StopStepUpDown address	E10081

- *Roller shutter % opening/closing*

Hex message			
Function	Fixed field	DPT	Function encoding
Roller shutter OPEN	BC10AB	DPTx_ShutterPosition address	E2008000
Roller shutter 50%			E2008080
Roller shutter CLOSED			E20080FF

SOUND SYSTEM

- *Audio zone ON/ OFF*

Hex message			
Function	Fixed field	DPT	Function encoding
ON	BC10AB	DPTx_AudioOnOff	E10081
OFF			E10080

- *Audio volume % control*

Hex message			
Function	Fixed field	DPT	Function encoding
Volume at 25%	BC10AB	DPTx_VolumeValue address	E2008019
Volume at 50%			E2008032
Volume at 75%			E200804B
Volume at 100%			E2008064

- *Change audio source*

Hex message			
Function	Fixed field	DPT	Function encoding
Skip current channel	BC10AB	DPTx_SkipChannelTrack	E10081

TEMPERATURE CONTROL

- *Send thermostat/probe temperature setpoint*

Hex message			
Function	Fixed field	DPT	Function encoding
Value 10°C	BC10AB	DPTx_TemperatureSetpoint1 address	E3008003E8
Value 15°C			E3008005DC
Value 20°C			E3008007D0
Value 25°C			E300800CE2
Value 30°C			E300800DDC

Configuration with View Pro App

• Change probe/thermostat operating mode

Function	Hex message		
	Fixed field	DPT	Function encoding
Automatic	BC10AB	DPTx_HvacMode address	E2008000
Manual			E2008001
Reduction			E2008002
Absence			E2008003
Protection			E2008004
OFF			E2008006

• Send external temperature on HVAC controller

Function	Hex message		
	Fixed field	DPT	Function encoding
Value 10°C	BC10AB	DPTx_TemperatureValue * address	E3008003E8
Value 15°C			E3008005DC
Value 20°C			E3008007D0
Value 25°C			E300800CE2
Value 30°C			E300800DDC

* In sensor application, when the probe is configured for reading via bus.

SCENARIOS

• Scenario activation

Function	Hex message		
	Fixed field	DPT	Function encoding
Scenario activation	BC10AB	DPTx_SceneActivator1 * address	E2008001
		DPTx_SceneActivator2 ** address	

* For single key or lower button in the case of rocker buttons.

** Upper button in the case of rocker buttons.

EXAMPLES:

ON/OFF for relay.

To compose the message, you need to know the address assumed by the DPTx_OnOff within the desired application.

From the application details page, select  ; the list of group addresses is displayed.

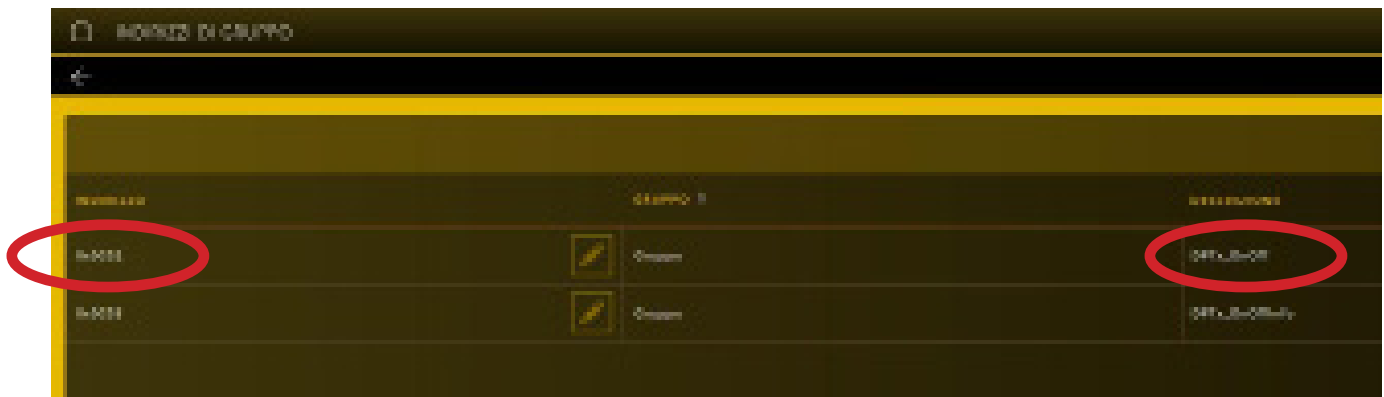

In this case, the DPTx_OnOff has address 0C02 as shown in red (always remove the 0x prefix).

The message for ON will therefore be BC10AB0C02E10081 while the message for OFF will instead be BC10AB0C02E10080.

Configuration with View Pro App

Roller shutter up/down and stop

To compose the up and down message, you need to know the address assumed by the DPTx_UpDown within the desired application.

From the application details page, select ; the list of group addresses is displayed.

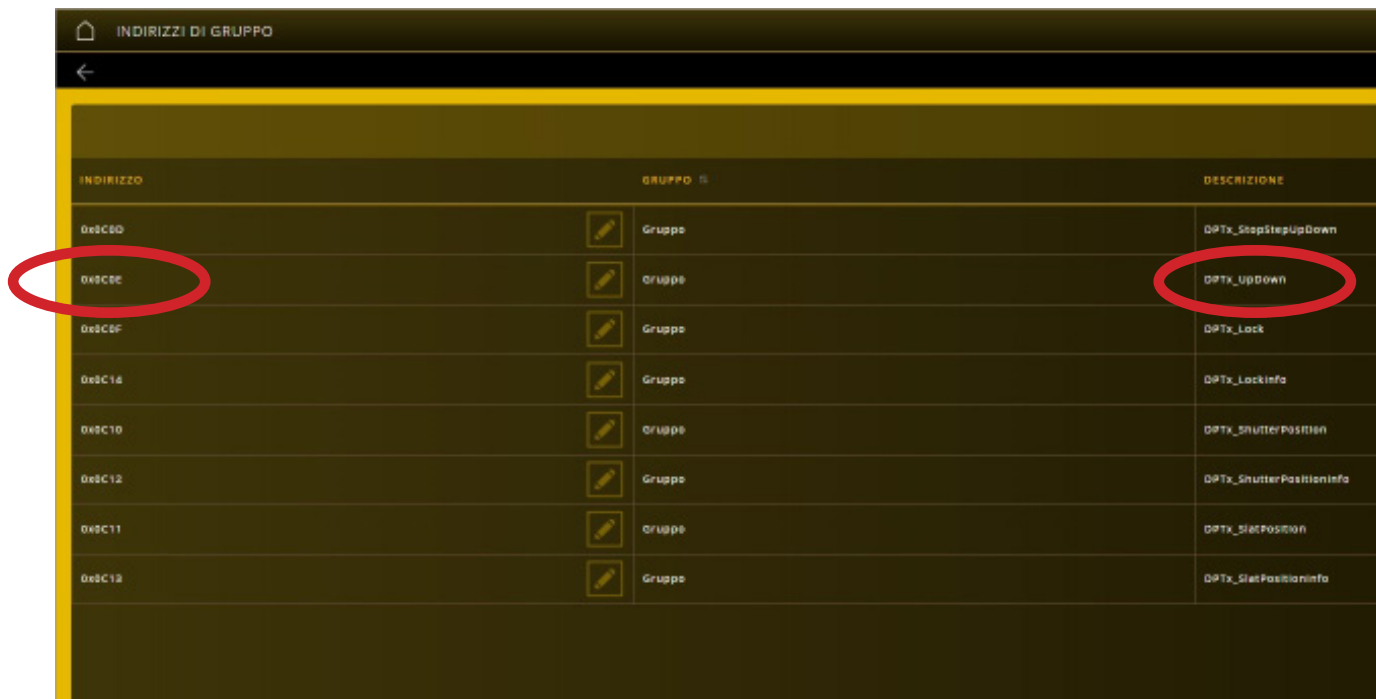

INDIRIZZO	GRUPPO ID	DESCRIZIONE
0x0C0D	Gruppo	DPTx_StopStepUpDown
0x0C0E	Gruppo	DPTx_UpDown
0x0C0F	Gruppo	DPTx_Lock
0x0C14	Gruppo	DPTx_LockInfo
0x0C10	Gruppo	DPTx_ShutterPosition
0x0C12	Gruppo	DPTx_ShutterPositionInfo
0x0C11	Gruppo	DPTx_SlatPosition
0x0C13	Gruppo	DPTx_SlatPositionInfo

In this case, the DPTx_UpDown has address 0C0E as shown in red (always remove the 0x prefix).

The message to raise the roller shutter will therefore be BC10AB0C0EE10080 while the message to lower it will instead be BC10AB0C0EE10081.

To compose the roller shutter stop message, you need to know the address assumed by the DPTx_StopStepUpDown.

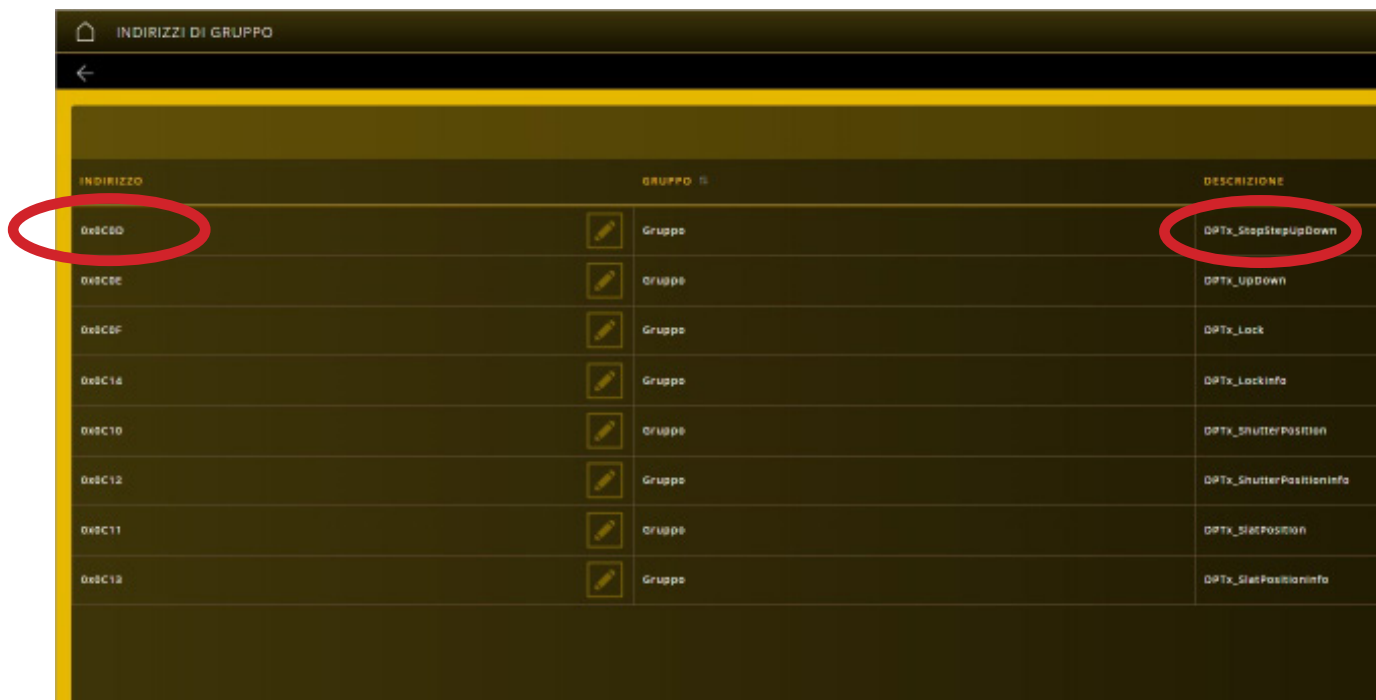

INDIRIZZO	GRUPPO ID	DESCRIZIONE
0x0C0D	Gruppo	DPTx_StopStepUpDown
0x0C0E	Gruppo	DPTx_UpDown
0x0C0F	Gruppo	DPTx_Lock
0x0C14	Gruppo	DPTx_LockInfo
0x0C10	Gruppo	DPTx_ShutterPosition
0x0C12	Gruppo	DPTx_ShutterPositionInfo
0x0C11	Gruppo	DPTx_SlatPosition
0x0C13	Gruppo	DPTx_SlatPositionInfo

In this case, the DPTx_StopStepUpDown has address 0C0D as shown in red (always remove the 0x prefix).

The message to raise the roller shutter all the way up will therefore be BC10AB0C0DE10081.

Configuration with View Pro App

Sending the temperature setpoint

To compose the message, you need to know the address assumed by the TemperatureSetpoint1 within the desired application.

From the application details page, select ; the list of group addresses is displayed.

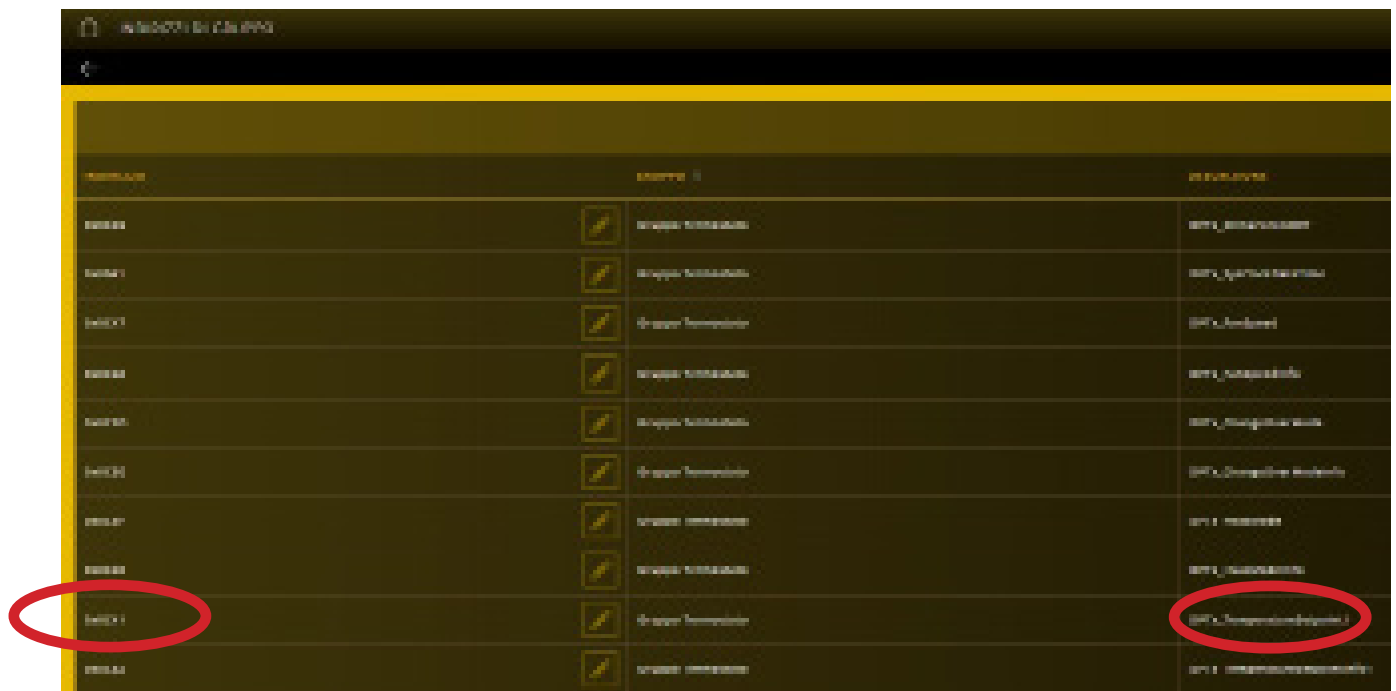

In this case, the DPTx_TemperatureSetpoint1 has address 0C41 as shown in red (always remove the 0x prefix).

The messages will therefore be as follows:

- BC10AB0C41E3008003E8 for a setpoint of 10 °C
- BC10AB0C41E3008005DC for a setpoint of 15 °C
- BC10AB0C41E3008007D0 for a setpoint of 20 °C
- BC10AB0C41E300800CE2 for a setpoint of 25 °C
- BC10AB0C41E300800DDC for a setpoint of 30 °C

Audio volume % control

To compose the message, you need to know the address assumed by the DPTx_VolumeValue within the desired application.

From the application details page, select ; the list of group addresses is displayed.

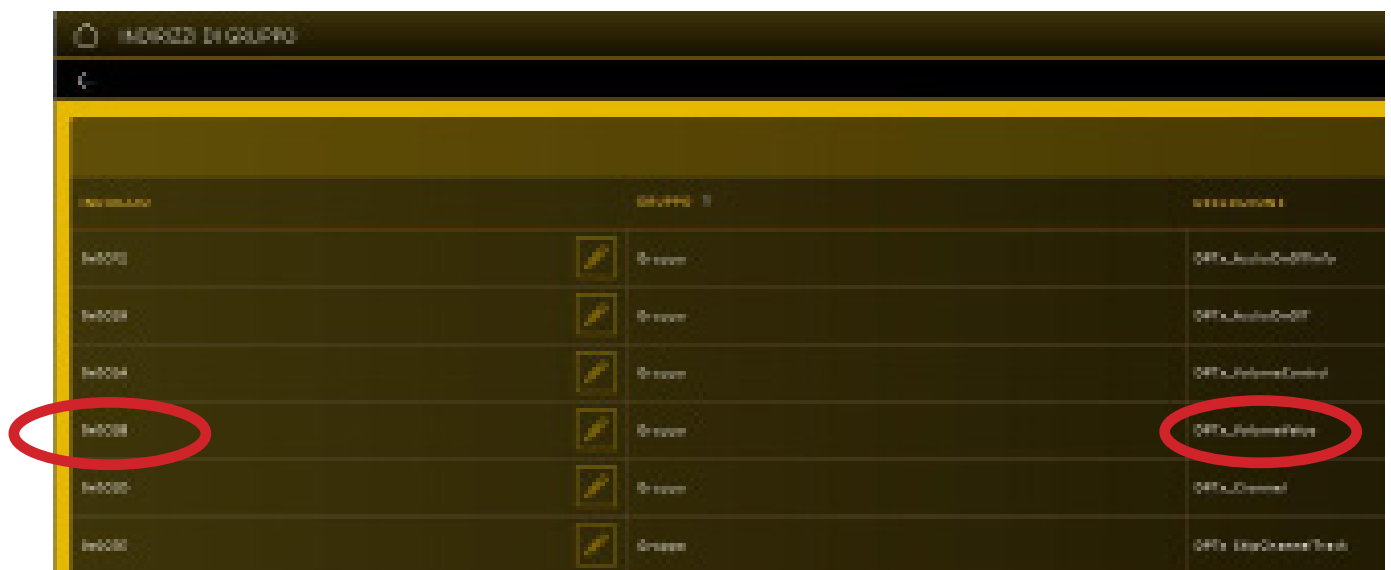

In this case, the DPTx_VolumeValue has address 0CEB as shown in red (always remove the 0x prefix).

The messages will therefore be as follows:

Configuration with View Pro App

- BC10AB0CEBE2008019 for volume at 25%;
- BC10AB0CEBE2008032 for volume at 50%;
- BC10AB0CEBE200804B for volume at 75%;
- BC10AB0CEBE2008064 for volume at 100%.

Change audio source

To compose the message, you need to know the address assumed by the DPTx_SkipChannelTrack within the desired application.



Indirizzo	Gruppo	Indirizzo
0C00	Gruppo	DPTx_AudioControl
0C08	Gruppo	DPTx_AudioControl
0C04	Gruppo	DPTx_VolumeControl
0C08	Gruppo	DPTx_VolumeControl
0C05	Gruppo	DPTx_Channel
0CEE	Gruppo	DPTx_SkipChannelTrack
0C07	Gruppo	DPTx_Line
0C0A	Gruppo	DPTx_Spatialization
0C0B	Gruppo	DPTx_Spatialization

In this case, the DPTx_SkipChannelTrack has address 0CEE as shown in red (always remove the 0x prefix).

The message to change audio source will therefore be BC10AB0CEEE10081.

Configuration with View Pro App

- The LOG menu stores all the operations performed on the system via the gateway; this view can also be filtered by level and category by selecting the desired ones with

DATA	LIVELLO	CATEGORIA	MESSAGGIO
10 luglio 2019 10:07:36.000	Informazione	Manutenzione	Loggi Autocostituzione
10 luglio 2019 10:20:04.000	Informazione	Manutenzione	Controllo ed on dispositivo MT04_A3200-BA000 G
10 luglio 2019 10:21:53.000	Informazione	Manutenzione	Loggi OffTheInfolore
10 luglio 2019 10:23:01.000	Informazione	Manutenzione	Dispositivo di sicurezza RT14_A3200-F0000 G
10 luglio 2019 10:23:41.000	Informazione	Manutenzione	Loggi OffTheInfolore
10 luglio 2019 10:23:46.000	Informazione	Manutenzione	Controllo ed on dispositivo MT04_A3200-BA000 G
10 luglio 2019 10:23:50.000	Informazione	Manutenzione	Loggi OffTheInfolore
10 luglio 2019 10:23:56.000	Informazione	Manutenzione	Dispositivo di sicurezza RT14_A3200-F0000 G
10 luglio 2019 10:23:58.000	Informazione	Manutenzione	Loggi OffTheInfolore
10 luglio 2019 10:24:06.000	Informazione	Manutenzione	Controllo ed on dispositivo MT04_A3200-BA000 G
10 luglio 2019 10:24:04.000	Informazione	Manutenzione	Loggi OffTheInfolore
10 luglio 2019 10:24:04.000	Informazione	Manutenzione	Dispositivo di sicurezza RT14_A3200-F0000 G
10 luglio 2019 10:23:51.000	Informazione	Manutenzione	Applicazione create I. Videofolletto Data alternata
10 luglio 2019 10:07:06.000	Informazione	Manutenzione	Applicazione create I. Installa
10 luglio 2019 10:06:52.000	Informazione	Manutenzione	Arco di apertura
10 luglio 2019 09:00:10.000	Informazione	Manutenzione	Trasmissione Notifiche

Use "EXPORT SYSTEM LOG" to export the information onto a file that can then be consulted at a later date or kept as an archive.

- The DEVICE RESET option restores the factory settings of the device without removing them from the system.

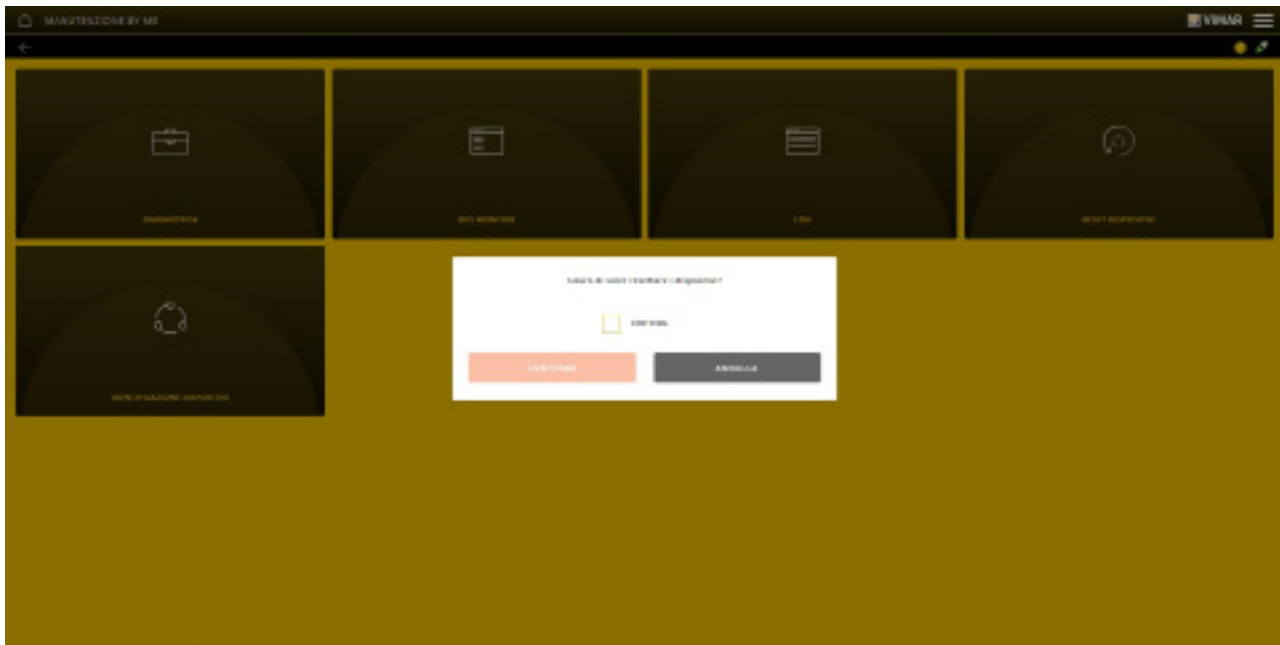

Select CONFIRM with and then click on RESET.

Configuration with View Pro App

- The DEVICE IDENTIFICATION option is used to display the information regarding a device that has already been configured, such as the physical address, the relevant group and the type of device itself (push button, dimmer, etc.). This function is useful for instance to identify the devices that have not been recognised and need to be reset.

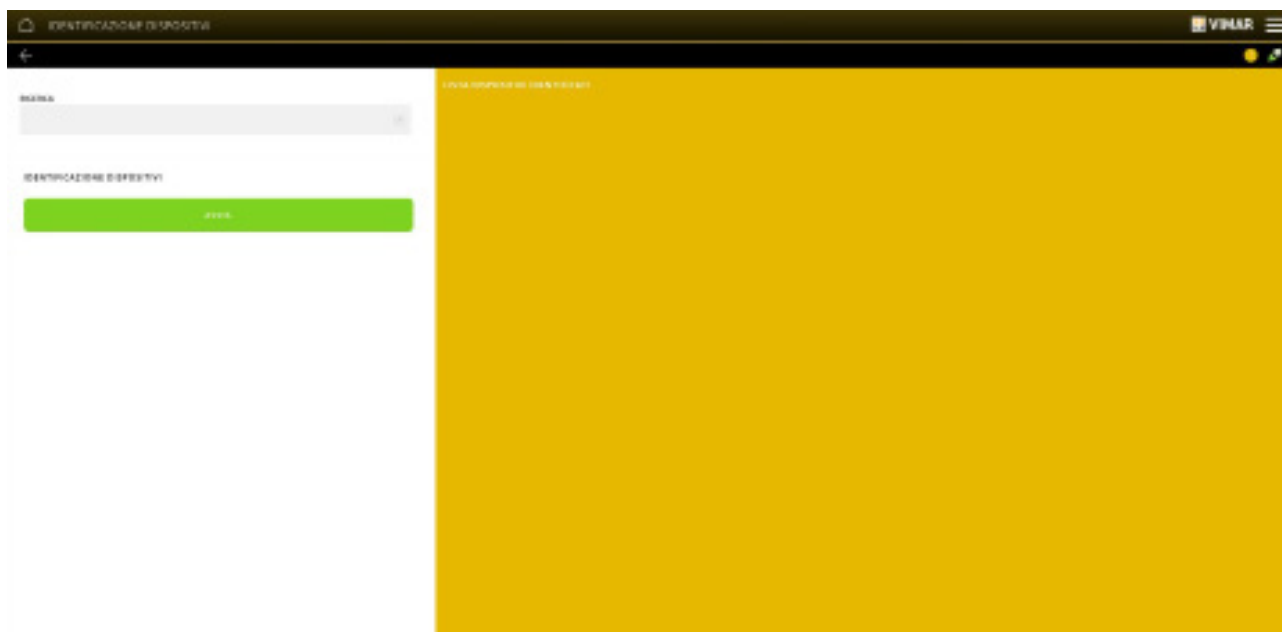

Select START and press the configuration push button on all the devices to be identified.

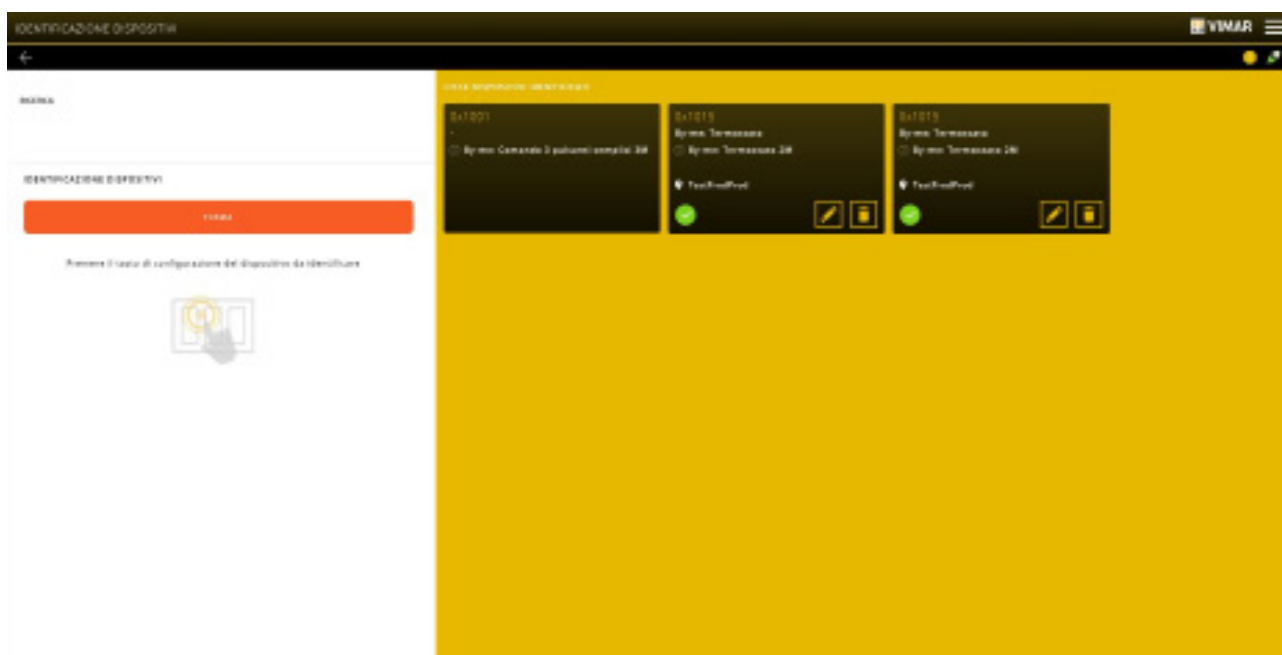









To complete the operation, select STOP.

All the devices identified are displayed, and you can then access the respective detailed information.



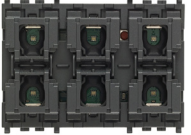

5. CONTROL DEVICES

5.1 Devices

The control devices are the following:

	<p>22481.x: Vintage 1-toggle home automation system control device, RGB LED visible in darkness with brightness control - 1 module.</p>
	<p>22482.x: Vintage 2-toggle home automation system control device, RGB LED visible in darkness with brightness control - 2 modules.</p>
	<p>30480-01480: Home automation control device with four push buttons, RGB LED visible in darkness with brightness control, to be completed with interchangeable half-button caps: 1 or 2 module Eikon, 2 module Arké or Plana.</p>
	<p>30481-01481: Home automation control device with four push buttons and actuator with change-over relay output 16 A 120-240 V~ 50/60 Hz, RGB LED visible in darkness with brightness control, to be completed with interchangeable half-button caps: 1 or 2 module Eikon, 2 module Arké or Plana.</p>
	<p>30482-01482: Home automation control device with four push buttons and actuator for 1 roller shutter with slat orientation with change-over relay output for cos ϕ motor 0.6 2 A 120-240 V~ 50/60 Hz, RGB LED visible in darkness with brightness control, to be completed with interchangeable half-button caps: 1 or 2 module Eikon, 2 module Arké or Plana.</p>
	<p>30485-01485: Home automation control device with six push buttons, RGB LED visible in darkness with brightness control, to be completed with interchangeable half-button caps: 1 or 2 module Eikon, 3 module Arké or Plana.</p>
	<p>30486-01486: Home automation control device with six push buttons and actuator with change-over relay output 16 A 120-240 V~ 50/60 Hz, RGB LED visible in darkness with brightness control, to be completed with interchangeable half-button caps: 1 or 2 module Eikon, 3 module Arké or Plana.</p>
	<p>30487-01487: Home automation control device with six push buttons and actuator for 1 roller shutter with slat orientation with change-over relay output for cos ϕ motor 0.6 2 A 120-240 V~ 50/60 Hz, RGB LED visible in darkness with brightness control, to be completed with interchangeable half-button caps: 1 or 2 module Eikon, 3 module Arké or Plana.</p>
	<p>01475: Module with 3 programmable digital inputs for potential-free contacts, 3 outputs for LED control, By-me home automation system, flush mounting (retrofit).</p>

Control devices

	<p>01476: Module with 2 programmable digital inputs for potential-free contacts, 1 output for roller shutter with slat orientation and relay for cos ϕ motor 0.6 2 A 120-230 V~, 2 outputs for LED control, By-me home automation system, flush mounting (retrofit).</p>
	<p>01477: Module with 2 programmable digital inputs for potential-free contacts, 1 light control NO relay output 10 A 120-230 V~ 50/60 Hz, 2 outputs for LED control, By-me home automation system, flush mounting (retrofit).</p>
	<p>30488-01488: Home automation system control device with four push buttons and 240 V~ 50/60Hz phase-cut dimmer, for 40-200 W incandescent lamps, electronic transformers 40-300 VA at 240 V~, 20-150 VA at 120 V~, CFL lamps 10-200 W at 240 V~, 5-100 W at 120 V~, LED lamps 3-200 W at 240 V~, 3-100 W at 120 V~, RGB LED visible in darkness with brightness control, to be completed with interchangeable half-button caps: 1 or 2 module Eikon, 2 module Arké or Plana.</p>
	<p>30489-01489: Home automation control device with four push buttons, 1 0/1-10 V SELV output, 1 NO contact relay output 2A 120-240 V~ 50/60 Hz for ballast and LED driver, RGB LED visible in darkness with brightness control, to be completed with interchangeable half-button caps: 1 or 2 module Eikon, 2 module Arké or Plana.</p>

Control devices

5.2 Functional units of art. 22481.x, 22482.x, 30480-01480, 30481-01481, 30482-01482, 30485-01485, 30486-01486 and 30487-01487

Description of functional units

PUSH BUTTON

- Push button: to send ON and OFF messages over the bus as described in the "push button behaviour" parameter.
- Dimmer control: to control dimmer actuators.
- Roller shutter control: to control the functional unit of shutters with no slats (as each control is the opposite of the previous one, at each long press of the push button, the movement of the roller shutter changes between up and down).
- Timed only control*: to activate a timer
- Timed* and ON/OFF control: to activate a timer and send an ON/OFF control, depending on how long the push button is pressed (for example, short press for timed and long press for ON/OFF).
- Scenario control: to call up and save a scenario.
- Send value: to send the value selected during configuration when the push button is pressed.
- Sleep: to call up the sleep function in the sound system.
- Audio monitoring: audio monitoring control (if paired with a microphone module).

ROCKER BUTTON

- Rocker button: to send ON and OFF controls.
- Dimmer control: to control dimmer actuators.
- Roller shutter control: to control the roller shutter functional unit (normal or with slats).
- Timed only control*: to activate a timer
- Timed* and ON/OFF control: to activate a timer and send an ON/OFF control, depending on how long the push button is pressed (for example, short press for timed and long press for ON/OFF).
- Volume On/Off: on/off and volume control for the sound system.
- Sleep: to call up the sleep function in the sound system.
- Ch+/Track+ : ch+/track+ control for sound system.

ACTUATOR

- Actuator: to manage a lights actuator.

Receives the following control requests: load on/off, scenario save and recall.

- Timed actuator: also for the timed management of a lights actuator.

Receives the following control requests: timed load on/off, load on/off, scenario save and recall.

ROLLER SHUTTER ACTUATOR

- Roller shutter actuator: to manage the roller shutter.
- Slats: to manage the roller shutter + slat

These functional units receive the following control requests: roller shutter opening/closing, slat rotation, roller shutter height and slat rotation value setting, scenario saving and recall, logic unit forcing.

* Configuration of the timed control is only possible if there is already at least one actuator in the application with a timed function.

Functional unit	Article		
	Home automation system control unit with push buttons art. 22481.x-22482.x 30480-01480-30485-01485	Home automation system control unit with push buttons and actuator with change-over relay output art. 30481-01481-30486-01486	Home automation system control unit with push buttons and actuator for 1 roller shutter with slat orientation art. 30482-01482-30487-01487
Actuator		✓	
Roller shutter actuator			✓
Slats actuator			✓
Timed actuator		✓	
Push Button	✓	✓	✓
Timed only control	✓	✓	
Timed only and ON/OFF control	✓	✓	
Scenario control	✓	✓	✓
Rocker button	✓	✓	✓
Dimmer control push button and rocker button Volume On/Off	✓	✓	✓
Send value	✓	✓	✓
Roller shutter control push button and rocker button	✓	✓	✓
ch+/track+	✓	✓	✓
Sleep push button and rocker button, audio monitoring push button	✓	✓	✓

IMPORTANT: Each button can be configured like a push button and the buttons for the same device can be grouped together to act as a rocker button.

Control devices

5.2.1 Configuration of art. 22481.x, 22482.x, 30480-01480 and 30485-01485

The functional units that the devices make available are as follows:

- 2 push buttons or 1 rocker button for art. 22481.x
- 4 push buttons or 2 rocker buttons for art. 22482.x-30480-01480
- 6 push buttons or 3 rocker buttons for art. 30485-01485

FUNCTIONAL UNITS

• For the push button logic function, one of the following functional units can be selected:

- push button
- dimmer control
- roller shutter control
- timed only control*
- timed* and ON/OFF control
- roller shutter control
- scenario control
- send value
- sleep (control for sound system)
- audio monitoring (control for sound system)

• For the rocker button logic function, one of the following functional units can be selected:

- rocker button
- dimmer control
- roller shutter control
- timed only control*
- timed* and ON/OFF control
- Volume On/Off (volume control for sound system)
- sleep (control for sound system)
- ch+/track+ (control for sound system)

* Configuration of the timed control is only possible if there is already at least one actuator in the application with a timed function.

5.2.2 Configuration of art. 30481-01481 and 30486-01486

The functional units that the devices make available are as follows:

- 4 push buttons or 2 rocker buttons + 1 relay actuator for art. 30481-01481
- 6 push buttons or 3 rocker buttons + 1 relay actuator for art. 30486-01486

FUNCTIONAL UNITS

• For the push button logic function, one of the following functional units can be selected:

- push button
- dimmer control
- roller shutter control
- timed only control*
- timed* and ON/OFF control
- scenario control
- send value
- sleep (control for sound system)
- audio monitoring (control for sound system)

• For the rocker button logic function, one of the following functional units can be selected:

- rocker button
- dimmer control
- roller shutter control
- timed only control*
- timed* and ON/OFF control
- Volume On/Off (volume control for sound system)
- sleep (control for sound system)
- ch+/track+ (control for sound system)

• For the actuator output, one of the following functional units can be selected:

- actuator
- timed actuator

* Configuration of the timed control is only possible if there is already at least one actuator in the application with a timed function.

Control devices

5.2.3 Configuration of art. 30482-01482 and 30487-01487

The functional units that the devices make available are as follows:

- 4 push buttons or 2 rocker buttons + 1 roller shutter and slat actuator for art. 30482-01482
- 6 push buttons or 3 rocker buttons + 1 roller shutter and slat actuator for art. 30487-01487

FUNCTIONAL UNITS

- For the push button logic function, one of the following functional units can be selected:
 - push button
 - dimmer control
 - roller shutter control
 - timed only control*
 - timed* and ON/OFF control
 - scenario control
 - send value
 - sleep (control for sound system)
 - audio monitoring (control for sound system)
- For the rocker button logic function, one of the following functional units can be selected:
 - rocker button
 - dimmer control
 - roller shutter control
 - timed only control*
 - timed* and ON/OFF control
 - Volume On/Off (volume control for sound system)
 - sleep (control for sound system)
 - ch+/track+ (control for sound system)
- For the roller shutter, one of the following functional units can be selected:
 - roller shutter actuator
 - slats actuator

Caution: after the functional unit configuration, you need to open and close each roller shutter completely to carry out the calibration process.

* Configuration of the timed control is only possible if there is already at least one actuator in the application with a timed function.

5.3 Parameters of art. 30480-01480, 30481-01481, 30482-01482, 30485-01485, 30486-01486 and 30487-01487

Device parameters can be set and/or modified in order to customise their functions and adapt the system to the various installation requirements.

Functional units and their parameters

Description of parameters

ACTUATOR

- On delay and off delay (they are delay times that can be set for actuating the On and Off request): from 0 s to 12 h with default value 0 s.
- On time duration for one-position stable operation (this is the activation time for one-position stable operation): from 1 s to 12 h with default value 30 s.
- Warning time (this is a time that is added to the activation time of the one-position stable actuator. At the end of the activation time the relay switches off for 0.5 s and then switches back on for the warning time): from 0 s to 12 h with default value 0 s.
- Output status at power-on and output status at power-down (this allows you to set the status of the actuator when switching off and when power is restored respectively): ON/OFF/Unchanged with default value "Unchanged".
Note: If the value "unchanged" is selected for the parameter "output status on power on", on power on, the actuator will return to its position immediately prior to the power down, independently of forcing (ON or OFF) required on power down.
- Operation (this allows you to set the operation of the actuator): monostable/bistable with default value "two position stable".
- Status at rest of relay contact: normally open (default value) or normally closed

ROLLER SHUTTER AND SLAT ACTUATOR

- Rise and fall time (these are the roller shutter raising and lowering times): 10 s to 1 h with default value 180 s.
- Full slat rotation time: from 500 ms to 5 s with default value 2 s.
- Behaviour at power-on (allows you to set whether when power is restored the roller shutter opens, closes, remains in the current position or you can choose the height of the roller shutter and the tilt of the slats): all down, all up, no action, default position. Default value "no action".
- Roller shutter position at power-on (allows you to set the position of the roller shutter when power is restored): from 0 to 100% with default value 50%.
- Scenario recall execution delay (allows you to delay execution of the control so as not to actuate all the roller shutters at once): from 0 s to 250 s with default value 0 s.
- Control execution delay: from 0 s to 250 s with default value 0 s.
- Tilt of slats at power-on (allows you to set the position of the slat when power is restored): from 0 to 100% with default value 50%.
- Position on forcing (allows you to set the behaviour of the roller shutter upon the forcing request): all down, all up, fixed, preset position with default value "fixed". It is necessary to observe the value set by the "roller shutter position on forcing" and "slat tilt on forcing" parameters.
- Position on end of forcing (allows you to set the behaviour of the roller shutter at the end of forcing): all down, all up, fixed, preset position with default value "fixed". It is necessary to observe the value set by the "roller shutter position on forcing" and "slat tilt on forcing" parameters; it returns to the previous value with the request for forcing.
- Roller shutter position on forcing (can be used in the "position on forcing" and "position on end of forcing" parameters): from 0 to 100% with default value 50%.
- Slat tilt on forcing (can be used in the "position on forcing" and "position on end of forcing" parameters): from 0 to 100% with default value 50%.

Control devices

PUSH BUTTON AND ROCKER BUTTON

- Push button behaviour: normal push button ON when the button is pressed, OFF when it is released, reversed push button OFF when pressed, ON when released, toggle on the rising edge, toggle on the falling edge, toggle on both edges, ON only ON when pressed, OFF only OFF when pressed.
Default value "Toggle on the rising edge".
- Enable scenario saving (this parameter is for the scenario recall push button that allows you to choose whether, with a long press, the push button sends a request to save the current scenario). Default value "Disabled".
- Long press time: from 0.5 ms to 30 s with default value 0.5 s.
- Short/long press behaviour: normal or reversed with default value "normal". This parameter is also useful in the case of actuators with a timed function to invert the two ON/OFF and timer controls.
- Up/Down Orientation:
 - (ON when the upper button is pressed and OFF when the lower button is pressed or vice-versa).
 - only valid for the dimmer control (ON and up adjustment when the upper button is pressed and OFF and down adjustment when the lower button is pressed or vice-versa).
 - only valid for the roller shutter push button (roller shutter up on long pressing of the upper button and roller shutter down on long pressing of the lower button or vice-versa).
 - ch+ when the upper button is pressed and track+ when the lower button is pressed or vice-versa.
- Output value (when the button is pressed the value chosen with this parameter is sent): from 0 to 100% with default value 0%.
- Roller shutter behaviour (valid for roller shutter push button and rocker button): parameter allowing you to choose whether or not on release from a long press the stop control is sent to the roller shutter.
- LED colour: allows you to select the colour of each individual LED from a default list or to set the desired RGB coordinate directly.
- LED on brightness and LED off brightness:
 - For the push button, for the dimmer control push button, for the audio monitoring and sleep push button: possibility of setting the brightness level of the LEDs when the paired load is activated or deactivated (high brightness, medium brightness, low brightness, off)
 - For the roller shutter push button, for the scenario control push button and for the send value push button: on pressing the button the LED is on for 3 s at the brightness level set with the parameter: "LED on brightness".
- Upper LED on brightness, upper LED off brightness, lower LED on brightness, lower LED off brightness.
 - For the rocker button, for the dimmer control rocker button, for the sleep and ch+/track+ rocker button: possibility of setting the brightness level of both LEDs of the functional unit when the paired load is activated or deactivated (high brightness, medium brightness, low brightness, off).
 - For the roller shutter rocker button: on pressing the button, the LEDs of the functional unit light up for 3 s with the brightness level set with the parameters: "upper LED on brightness" and "lower LED on brightness".

Parameter	Functional units										
	Push Button	Dimmer control push button	Roller shutter control push button	Timed push button	Scenario control	Send value	Sleep and audio monitoring push button	Rocker button, sleep and ch+/track+ rocker button	Dimmer control rocker button	Roller shutter control rocker button	Timed rocker button
Push button behaviour	✓										
Long/short press behaviour				✓							✓
Enable scenario saving					✓						
Roller shutter long press			✓							✓	
LED ON brightness	✓	✓	✓	✓	✓	✓	✓				
LED OFF brightness	✓	✓	✓	✓	✓	✓	✓				
Upper LED ON brightness								✓	✓	✓	✓
Upper LED OFF brightness								✓	✓	✓	✓
Lower LED ON brightness								✓	✓	✓	✓
Lower LED OFF brightness								✓	✓	✓	✓
Long press time		✓	✓	✓	✓				✓	✓	✓
Output value						✓					
Rocker button orientation								✓	✓	✓	✓
LED colour	✓	✓	✓	✓	✓	✓	✓	✓	✓	✓	✓

Control devices

Parameter	Functional units			
	Actuator	Timed actuator	Roller shutter actuator	Slats actuator
ON delay and OFF delay	✓	✓		
ON time duration for one-position stable operation	✓	✓		
Warning time	✓	✓		
Output status at power-on and at power-down	✓	✓		
Operation	✓			
Default status	✓	✓		
Rise and fall time			✓	✓
Full slat rotation time				✓
Scenario control execution delay			✓	✓
Controls execution delay			✓	✓
Behaviour at power-on			✓	✓
Roller shutter position at power-on			✓	✓
Tilt of slats at power-on				✓
Position on forcing			✓	✓
Position on end of forcing			✓	✓
Roller shutter position on forcing			✓	✓
Slat tilt on forcing				✓

5.4 Functional units of art. 01475, 01476 and 01477.

Description of functional units

PUSH BUTTON

- **Push button:** to send ON and OFF messages over the bus as described in the "input behaviour" parameter. It is only with this functional unit that traditional switches can be connected, in addition to push buttons.
- **Dimmer control:** to control dimmer actuators.
- **Roller shutter control:** to control the functional unit of shutters with no slats (as each control is the opposite of the previous one, at each long press of the push button, the movement of the roller shutter changes between up and down).
- **Timed only control*:** to activate a timer
- **Timed* and ON/OFF control:** to activate a timer and send an ON/OFF control, depending on how long the push button is pressed (for example, short press for timed and long press for ON/OFF).
- **Scenario control:** to call up and save a scenario.
- **Send value:** to send the value selected during configuration on the closure of the input.
- **Sleep:** to call up the sleep function in the sound system.
- **Audio monitoring:** audio monitoring control (if paired with a microphone module).

ROCKER BUTTON

Two inputs need to be used to carry out this function.

- **Rocker button:** to send ON and OFF controls on the same application when pressing input 1 or 2.
- **Dimmer control:** to control dimmer actuators.
- **Roller shutter control:** to control the roller shutter functional unit (normal or with slats).
- **Timed only control*:** to activate a timer
- **Timed* and ON/OFF control:** to activate a timer and send an ON/OFF control, depending on how long the push button is pressed (for example, short press for timed and long press for ON/OFF).
- **Volume OnOff:** on/off and volume control for the sound system.
- **Sleep:** to call up the sleep function in the sound system.
- **Ch+/Track+:** ch+/track+ control for sound system.

ACTUATOR

- **Actuator:** to manage a lights actuator.
This functional unit receives the following control requests: load on/off, timed load on, scenario save and recall.
- **Timed actuator:** also for the timed management of a lights actuator.
Receives the following control requests: double function of timed load and/or load on/off, scenario save and recall.
- **Circulation pump relay:** to manage the circulation pump.

ROLLER SHUTTER ACTUATOR

- **Roller shutter actuator:** to manage the roller shutter.
- **Slats:** to manage the roller shutter + slat
These functional units receive the following control requests: roller shutter opening/closing, slat rotation, roller shutter height and slat rotation value setting, scenario saving and recall, logic unit forcing.

* Configuration of the timed control is only possible if there is already at least one actuator in the application with a timed function.

Control devices

Functional unit	Article			
	Module with 9 inputs and 8 outputs art. 01470.1	Module with 3 digital inputs and 3 outputs for LED control art. 01475	Module with 2 digital inputs , 1 roller shutter output and 2 outputs for LED control art. 01476	Module with 2 digital inputs, 1 relay output and 2 outputs for LED control art. 01477
Actuator	✓			✓
Roller shutter actuator	✓		✓	
Slats actuator	✓		✓	
Push Button	✓	✓	✓	✓
Timed only control	✓	✓	✓	✓
Timed only and ON/OFF control	✓	✓	✓	✓
Scenario control	✓	✓	✓	✓
Rocker button	✓	✓	✓	✓
Dimmer control push button and rocker button, Volume On/Off	✓	✓	✓	✓
Send value	✓	✓	✓	✓
Roller shutter control push button and rocker button	✓	✓	✓	✓
ch+/track+	✓	✓	✓	✓
Sleep push button and rocker button, audio monitoring push button	✓	✓	✓	✓

5.4.1 Configuration of Module with 3 digital inputs and 3 outputs for LED control 01475

The functional units that the device makes available are as follows: 3 push buttons or 1 rocker button + 1 push button.

FUNCTIONAL UNITS

• For the push button logic function, one of the following functional units can be selected:

- push button
- dimmer control
- roller shutter control
- timed only control*
- timed* and ON/OFF control
- scenario control
- send value
- sleep (control for sound system)
- audio monitoring (control for sound system)

• For the rocker button logic function (consisting of inputs 1 and 2), one of the following functional units can be selected:

- rocker button
- dimmer control
- roller shutter control
- timed only control*
- timed* and ON/OFF control
- Volume On/Off (volume control for sound system)
- sleep (control for sound system)
- ch+/track+ (control for sound system)

* Configuration of the timed control is only possible if there is already at least one actuator in the application with a timed function.

Control devices

5.4.2 Configuration of Module with 2 digital inputs , 1 roller shutter output and 2 outputs for LED control 01476

The functional units that the device makes available are as follows: 2 push buttons or 1 rocker button, 1 roller shutter actuator.

FUNCTIONAL UNITS

- For the push button logic function, one of the following functional units can be selected:
 - push button
 - dimmer control
 - roller shutter control
 - timed only control*
 - timed* and ON/OFF control
 - scenario control
 - send value
 - sleep (control for sound system)
 - audio monitoring (control for sound system)
- For the rocker button logic function (consisting of inputs 1 and 2), one of the following functional units can be selected:
 - rocker button
 - dimmer control
 - roller shutter control
 - timed only control*
 - timed* and ON/OFF control
 - Volume On/Off (volume control for sound system)
 - sleep (control for sound system)
 - ch+/track+ (control for sound system)
- For the roller shutter, one of the following functional units can be selected:
 - roller shutter actuator
 - slats actuator

Caution: after the functional unit configuration, you need to open and close each roller shutter completely to carry out the calibration process.

* Configuration of the timed control is only possible if there is already at least one actuator in the application with a timed function.

5.4.3 Configuration of Module with 2 digital inputs, 1 relay output and 2 outputs for LED control 01477

The functional units that the device makes available are as follows: 2 push buttons or 1 rocker button, 1 relay.

FUNCTIONAL UNITS

- For the push button logic function, one of the following functional units can be selected:
 - push button
 - dimmer control
 - roller shutter control
 - timed only control*
 - timed* and ON/OFF control
 - scenario control
 - send value
 - sleep (control for sound system)
 - audio monitoring
 - For the rocker button logic function (consisting of inputs 1 and 2), one of the following functional units can be selected:
 - rocker button
 - dimmer control
 - roller shutter control
 - timed only control*
 - timed* and ON/OFF control
 - Volume On/Off (volume control for sound system)
 - sleep (control for sound system)
 - ch+/track+ (control for sound system)
 - For the relay, the following functional unit can be selected: **actuator and timed actuator.**
- * Configuration of the timed control is only possible if there is already at least one actuator in the application with a timed function.

Control devices

5.5 Parameters of art. 01475, 01476 and 01477.

Device parameters can be set and/or modified in order to customise their functions and adapt the system to the various installation requirements.

Functional units and their parameters

Description of parameters

ACTUATOR AND TIMED ACTUATOR

- **On delay and off delay** (they are delay times that can be set for actuating the On and Off request): from 0 s to 12 h with default value 0 s.
- **On time duration for one-position stable operation** (this is the activation time for one-position stable operation): from 1 s to 12 h with default value 30 s.
- **Warning time** (this is a time that is added to the activation time of the one-position stable actuator. At the end of the activation time the relay switches off for 0.5 s and then switches back on for the warning time): from 0 s to 12 h with default value 0 s.
- **Output status at power-on and output status at power-down** (this allows you to set the status of the actuator when switching off and when power is restored respectively): ON/OFF/Unchanged with default value "Unchanged".
- **Operation** (this allows you to set the operation of the actuator): monostable/bistable with default value "two position stable" (this parameter is not present for the timed actuator functional unit).

ROLLER SHUTTER AND SLAT ACTUATOR

- **Rise and fall time** (these are the roller shutter raising and lowering times): 10 s to 1 h with default value 180 s.
- **Full slat rotation time**: from 500 ms to 5 s with default value 2 s.
- **Behaviour at power-on** (allows you to set whether when power is restored the roller shutter opens, closes, remains in the current position or you can choose the height of the roller shutter and the tilt of the slats): all down, all up, no action, default position. Default value no "action".
- **Roller shutter position at power-on** (allows you to set the position of the roller shutter when power is restored): from 0 to 100% with default value 50%.
- **Control execution delay**: from 0 s to 250 s with default value 0 s.
- **Tilt of slats at power-on** (allows you to set the position of the slat when power is restored): from 0 to 100% with default value 50%.
- **Position on forcing** (allows you to set the behaviour of the roller shutter upon the forcing request): all down, all up, fixed, preset position with default value "fixed". It is necessary to observe the value set by the "roller shutter position on forcing" and "slat tilt on forcing" parameters.
- **Position on end of forcing** (allows you to set the behaviour of the roller shutter at the end of forcing): all down, all up, fixed, preset position with default value "fixed". It is necessary to observe the value set by the "roller shutter position on forcing" and "slat tilt on forcing" parameters; it returns to the previous value with the request for forcing.
- **Roller shutter position on forcing** (can be used in the "position on forcing" and "position on end of forcing" parameters): from 0 to 100% with default value 50%.
- **Slat tilt on forcing** (can be used in the "position on forcing" and "position on end of forcing" parameters): from 0 to 100% with default value 50%.

PUSH BUTTON AND ROCKER BUTTON

- **Control input report**: normal push button **ON on closing, OFF on opening**, reversed push button **OFF on closing, ON on opening**, toggle on rising edge, toggle on both edges (to be used when a traditional switch is connected to the input), only **ON ON on closing, only OFF OFF on closing**. Default value "Toggle on the rising edge".
- **Enable scenario saving** (this parameter is for the scenario recall push button that allows you to choose whether, with a long press, the push button sends a request to save the current scenario). Default value "Disabled".
- **Long press time**: from 0.5 ms to 30 s with default value 0.5 s.
- **Short/long press behaviour**: normal or reversed with default value "normal". This parameter is also useful in the case of actuators with a timed function to invert the two ON/OFF and timer controls.
- **Up/Down Orientation**:
 - (ON on input 1 closing and OFF on input 2 closing or vice-versa).
 - only valid for the dimmer control (ON and up adjustment on input 1 closing and OFF and down adjustment on input 2 closing or vice-versa).
 - only valid for the roller shutter push button (roller shutter up on input 1 long closing and roller shutter down on input 2 long closing or vice-versa).
 - ch+ on input 1 closing and track+ on input 2 closing or vice-versa.
- **Output value** (when the input is closed the value chosen with this parameter is sent): from 0 to 100% with default value 0%.
- **LED management**:
 - **For the push button, for the dimmer control push button, for the sleep and audio monitoring push button**: Normal=LED on if paired load active and off if load deactivated; Reversed=LED off if paired load active and on if load deactivated; always on; Disabled = always off.
 - **For the roller shutter push button, for the scenario control push button and for the send value push button**: Normal=LED on for 3 s on input closing; Reversed=LED off for 3 s on input closing; always on; Disabled= always off.
 - **For the rocker button, for the dimmer control rocker button, for the sleep and ch+/track+ rocker button**: Normal=output 1 LED on if paired load active and off if load deactivated; Reversed=output 1 LED off if paired load active and on if load deactivated; always on; Disabled = always off. In the cases of Normal and Reversed, output 2 LED is reversed with respect to output 1
 - **For the roller shutter rocker button**: Normal=output 1 LED on for 3 s on input 1 closing; Reversed=output 1 LED off for 3 s on input 1 closing; always on; Disabled= always off.

N.B.: For the rocker button, in the event that a single LED is used, the latter needs to be connected to both outputs to have the closing feedback of both inputs.

Control devices

<i>Parameter</i>	<i>Functional units</i>								
	Push Button	Roller shutter and dimmer control push button	Timed push button	Scenario control	Send value	Sleep and audio monitoring push button	Rocker button, sleep and ch+/track+ rocker button	Dimmer control rocker button, Volume On/Off and roller shutter	Timed rocker button
Control input report	✓								
Enable scenario saving				✓					
Long/short press behaviour			✓						✓
Long press time		✓	✓	✓				✓	✓
Output value					✓				
Rocker button orientation							✓	✓	
LED management	✓	✓	✓	✓	✓	✓	✓	✓	✓
Operation*							✓	✓	

* The "Operation" parameter can only be used in the presence of a sound system (so for the sleep, ch+/track+, Volume On/Off functional units).

<i>Parameter</i>	<i>Functional units</i>			
	Actuator	Timed actuator	Roller shutter actuator	Slats actuator
ON delay and OFF delay	✓	✓		
ON time duration for one-position stable operation	✓	✓		
Warning time	✓	✓		
Output status at power-on and at power-down	✓	✓		
Operation	✓			
Rise and fall time			✓	✓
Full slat rotation time				✓
Scenario control execution delay			✓	✓
Controls execution delay			✓	✓
Behaviour at power-on			✓	✓
Roller shutter position at power-on			✓	✓
Tilt of slats at power-on				✓
Position on forcing			✓	✓
Position on end of forcing			✓	✓
Roller shutter position on forcing			✓	✓
Slat tilt on forcing				✓

Control devices

5.6 Functional units of art. 30488-01488 and 30489-01489

Description of functional units

PUSH BUTTON

- Push button: to send ON and OFF messages over the bus as described in the “push button behaviour” parameter.
- Dimmer control: to control dimmer actuators.
- Roller shutter control: to control the functional unit of shutters with no slats (as each control is the opposite of the previous one, at each long press of the push button, the movement of the roller shutter changes between up and down).
- Timed only control*: to activate a timer
- Timed* and ON/OFF control: to activate a timer and send an ON/OFF control, depending on how long the push button is pressed (for example, short press for timed and long press for ON/OFF).
- Scenario control: to call up and save a scenario.
- Send value: to send the value selected during configuration when the push button is pressed.
- Sleep: to call up the sleep function in the sound system.
- Audio monitoring: audio monitoring control (if paired with a microphone module).

ROCKER BUTTON

- Rocker button: to send ON and OFF controls.
- Dimmer control: to control dimmer actuators.
- Roller shutter control: to control the roller shutter functional unit (normal or with slats).
- Timed only control*: to activate a timer
- Timed* and ON/OFF control: to activate a timer and send an ON/OFF control, depending on how long the push button is pressed (for example, short press for timed and long press for ON/OFF).
- Volume On/Off: on/off and volume control for the sound system.
- Sleep: to call up the sleep function in the sound system.
- Ch+/Track+ : ch+/track+ control for sound system.

DIMMER ACTUATOR (only for art. 30488-01488)

- Actuator: to manage an actuator for light control.
Receives the following control requests: load on/off/control.
- Timed actuator: to manage an actuator for light control with a timer.
Receives the following control requests: load on/off/control.

PROPORTIONAL ACTUATOR (only for art. 30489-01489)

- Proportional actuator and timed proportional actuator: to control devices via 0-10 V output.
Receives the following control requests: load on/off/control.
- Proportional actuator for climate control: to control devices via 0-10 V output.
Receives the following control requests: load control.

* Configuration of the timed control is only possible if there is already at least one actuator in the application with a timed function.

IMPORTANT: Each button can be configured like a push button and the buttons for the same device can be grouped together to act as a rocker button.

5.6.1 Configuration of art. 30488-01488 and 30489-01489

FUNCTIONAL UNITS

- For the push button logic function, one of the following functional units can be selected:
 - push button
 - dimmer control
 - roller shutter control
 - timed only control*
 - timed* and ON/OFF control
 - scenario control
 - send value
 - sleep (control for sound system)
 - audio monitoring (control for sound system)
- For the rocker button logic function, one of the following functional units can be selected:
 - rocker button
 - dimmer control
 - roller shutter control
 - timed only control*
 - timed* and ON/OFF control
 - Volume On/Off (volume control for sound system)
 - sleep (control for sound system)
 - ch+/track+ (control for sound system)
- For the actuator output, one of the following functional units can be selected:
 - dimmer actuator (only for art. 30488-01488)
 - timed dimmer actuator (only for art. 30488-01488)
 - RGB dimmer actuator (only for art. 30488-01488)
 - proportional actuator (only for art. 30489-01489)
 - timed proportional actuator (only for art. 30489-01489)
 - proportional actuator for climate control function (only for art. 30489-01489)

* Configuration of the timed control is only possible if there is already at least one actuator in the application with a timed function.

Control devices

5.7 Parameters of art. 30488-01488 and 30489-01489

Device parameters can be set and/or modified in order to customise their functions and adapt the system to the various installation requirements.

Functional units and their parameters

Description of parameters

PUSH BUTTON AND ROCKER BUTTON

- **Push button behaviour:** normal push button ON when the button is pressed, OFF when it is released, reversed push button OFF when pressed, ON when released, toggle on the rising edge, toggle on the falling edge, toggle on both edges, ON only ON when pressed, OFF only OFF when pressed. Default value "Toggle on the rising edge".
- **Enable scenario saving** (this parameter is for the scenario recall push button that allows you to choose whether, with a long press, the push button sends a request to save the current scenario). Default value "Disabled".
- **Long press time:** from 0.5 ms to 30 s with default value 0.5 s.
- **Short/long press behaviour:** normal or reversed with default value "normal". This parameter is also useful in the case of actuators with a timed function to invert the two ON/OFF and timer controls.
- **Up/Down Orientation:**
 - (ON when the upper button is pressed and OFF when the lower button is pressed or vice-versa).
 - only valid for the dimmer control (ON and up adjustment when the upper button is pressed and OFF and down adjustment when the lower button is pressed or vice-versa).
 - only valid for the roller shutter push button (roller shutter up on long pressing of the upper button and roller shutter down on long pressing of the lower button or vice-versa).
 - ch+ when the upper button is pressed and track+ when the lower button is pressed or vice-versa.
- **Output value** (when the button is pressed the value chosen with this parameter is sent): from 0 to 100% with default value 0%.
- **Roller shutter behaviour** (valid for roller shutter push button and rocker button): parameter allowing you to choose whether or not on release from a long press the stop control is sent to the roller shutter.
- **LED colour:** allows you to select the colour of each individual LED from a default list or to set the desired RGB coordinate directly.
- **LED on brightness and LED off brightness:**
 - for the push button, for the dimmer control push button, for the audio monitoring and sleep push button: possibility of setting the brightness level of the LEDs when the paired load is activated or deactivated (high brightness, medium brightness, low brightness, off)
 - for the roller shutter push button, for the scenario control push button and for the send value push button: on pressing the button the LED is on for 3 s at the brightness level set with the parameter: "LED on brightness".
- **Upper LED on brightness, upper LED off brightness, lower LED on brightness, lower LED off brightness:**
 - for the rocker button, for the dimmer control rocker button, for the sleep and ch+/track+ rocker button: possibility of setting the brightness level of both LEDs of the functional unit when the paired load is activated or deactivated (high brightness, medium brightness, low brightness, off).
 - for the roller shutter rocker button: on pressing the button, the LEDs of the functional unit light up for 3 s with the brightness level set with the parameters: "upper LED on brightness" and "lower LED on brightness".

DIMMER ACTUATOR AND TIMED DIMMER ACTUATOR (only for art. 30488-01488)

- **Dimming speed** (allows you to select the dimming speed): minimum, normal, maximum with default normal.
- **Phase cutting** (only for art. 30488-01488, allows you to select the phase cutting according to the load connected): LE (leading edge), TE (trailing edge) with default LE.

Dimming with leading edge LE phase control

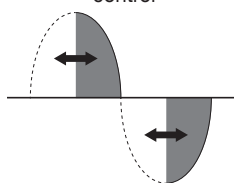

Dimming with trailing edge TE phase control

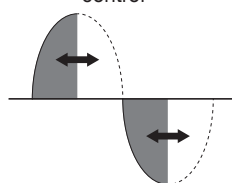

- **Minimum adjustment value** (defines the minimum brightness percentage during operation): from 15% to 50% with default value 25%.

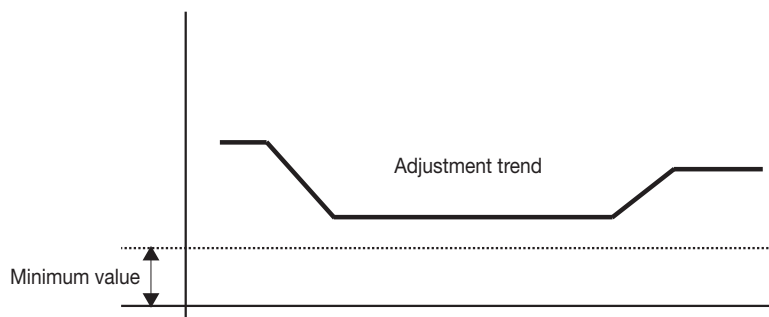

Control devices

- **Flash start** (allows you to select possible impulsive lamp lighting): active/not active with default value not active.

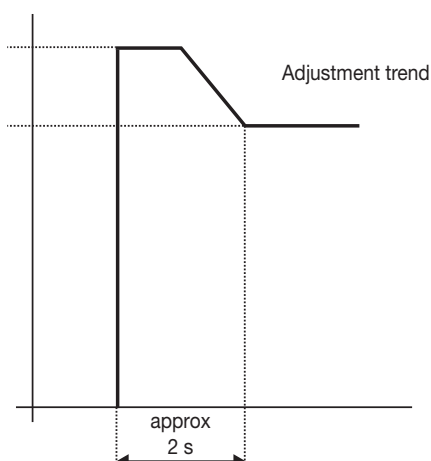

- **On time duration for one-position stable operation** (this is the activation time for one-position stable operation): from 100 ms to 1h and 48min with default value 1 min.
- **Maximum power-on ramp value** (this is the value reached by brightness at the end of the power-on ramp): from 0% to 100% with default value 0%. N.B: with a value of 0% the brightness value assumes the value of the last power-on done.
- **Minimum power-on ramp value** (this is the instantaneous brightness value upon power-on of the load before beginning the power-on ramp): from 0% to 100% with default value 25%. N.B: the minimum value should be less than the maximum value and more than the minimum adjustment value.
- **Power-on duration** (this is the duration of the power-on ramp, therefore from the minimum value of the power-on ramp to the maximum value of the power-on ramp): from 100 ms to 1h and 48min with default value 2 s.
- **Power-down duration** (this is the duration of the power-down ramp, therefore from the maximum value of the power-on ramp to the minimum value of the power-on ramp): from 100 ms to 1h and 48min with default value 2 s.

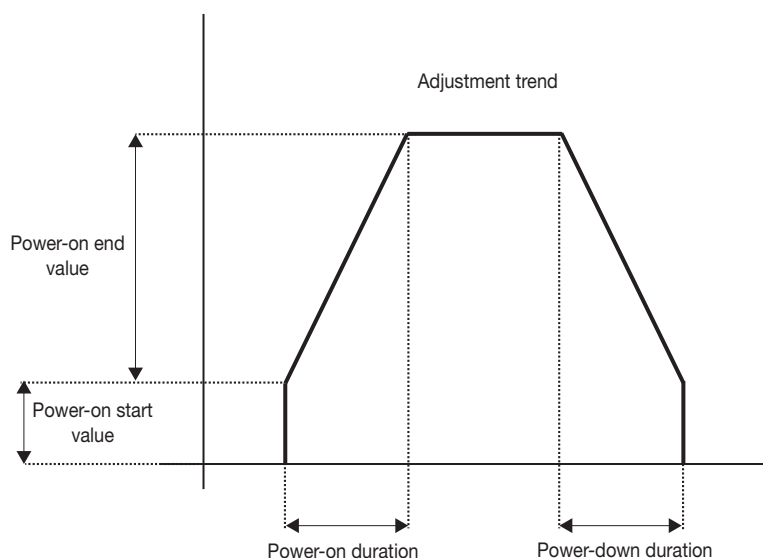

Control devices

- **Power-down delay** (delay times that can be set for actuating the Off request): from 0s to 1h and 48min with default value 0s.

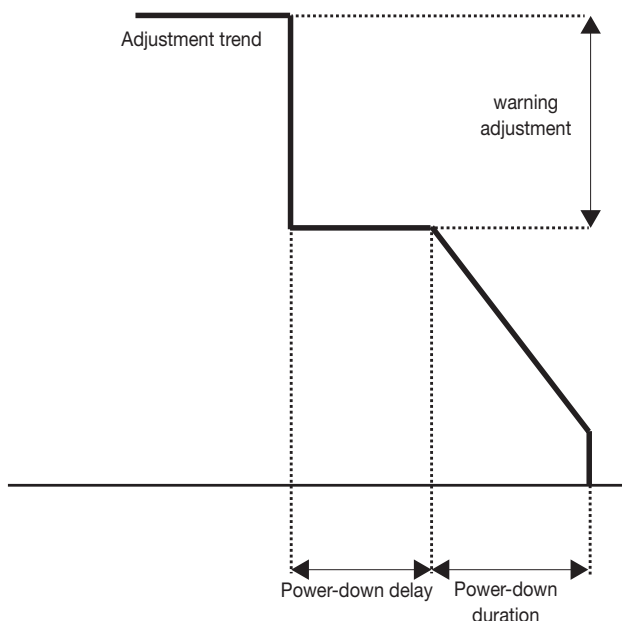

- **Transition duration following absolute value request** (this is the time set to reach a brightness level following a request for absolute value): from 100 ms to 1h and 48min with default value 2s.

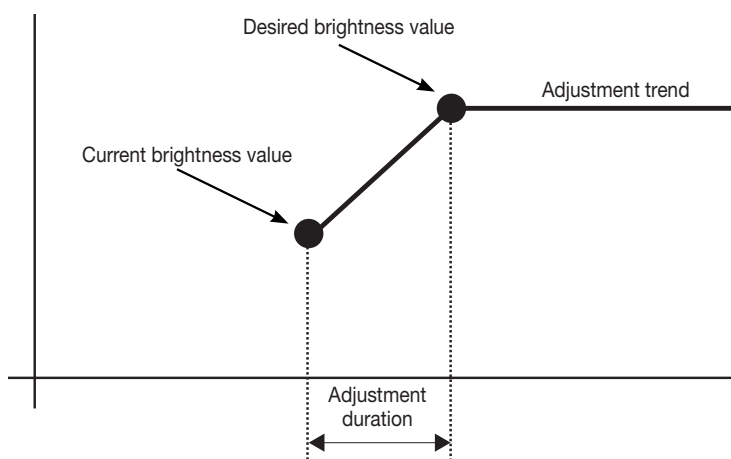

- **Operation** (this allows you to set the operation of the actuator): monostable/bistable with default value "two position stable" (this parameter is not present for the timed white dimmer functional unit).
- **Progressive power-down** (indicates the percentage decrease to take the load, starting with the current status, upon arrival of an off control and with a power-down delay other than 0): default value 50%.
- **Output status at power-on and output status at power-down** (this allows you to set the status of the output when switching off and when power is restored respectively): ON/OFF/Unchanged with default value "Unchanged".

RGB DIMMER ACTUATOR (only for art. 30488-01488)

- **Dimming speed** (allows you to select the dimming speed): minimum, normal, maximum with default normal.
- **Maximum power-on ramp value** (this is the value reached by brightness at the end of the power-on ramp): from 0% to 100% with default value 0%. N.B: with a value of 0% the brightness value assumes the value of the last power-on done.
- **Minimum power-on ramp value** (this is the instantaneous brightness value upon power-on of the load before beginning the power-on ramp): from 0% to 100% with default value 25%. N.B: the minimum value must be less than the maximum value.
- **Power-on duration** (this is the duration of the power-on ramp, therefore from the minimum value of the power-on ramp to the maximum value of the power-on ramp): from 100 ms to 1h and 48min with default value 2 s.
- **Power-down duration** (this is the duration of the power-down ramp, therefore from the maximum value of the power-on ramp to the minimum value of the power-on ramp): from 100 ms to 1h and 48min with default value 2 s.
- **Power-down delay** (delay times that can be set for actuating the Off request): from 0s to 1h and 48min with default value 0s.
- **Transition duration following absolute value request** (this is the time set to reach a brightness level following a request for absolute value): from 100 ms to 1h and 48min with default value 2s.

Control devices

- **Output status at power-on and output status at power-down** (this allows you to set the status of the output when switching off and when power is restored respectively): ON/OFF/Unchanged with default value "Unchanged".
- **List of colours for the fading show** (allows you to set the list of colours used during the fading show): list of 6 settable colours for the fading show with default value "red, green, blue, yellow, light blue, white".
- **Fading show transition time** (this is the time set to move from one colour to the next): from 100 ms to 1h and 48min with default value 2s.
- **Fading show on time** (this is how long one colour is on during the fading show): from 100 ms to 1h and 48min with default value 2s.

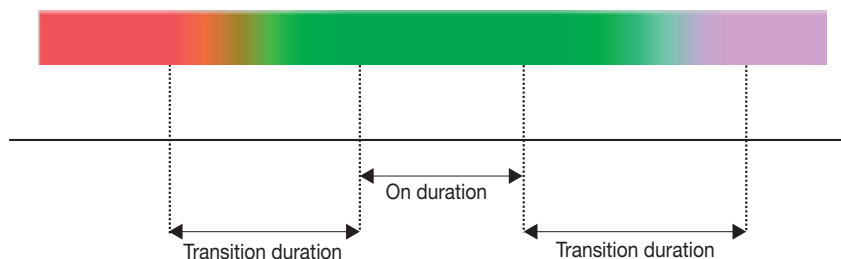

PROPORTIONAL ACTUATOR AND TIMED PROPORTIONAL ACTUATOR (only for art. 30489-01489)

- **Dimming speed** (allows you to select the dimming speed of the output): minimum, normal, maximum with default normal.
- **Off status value** (defines the value of the output when the dimmer is off): 0 V, minimum, maximum.
- **Minimum adjustment value** (defines the minimum adjustment value during operation): from 0% to 100% with default value 25%.
- **Minimum output value** (defines the minimum value of the analogue output): from 0.0 mV to 9600 mV in steps of 100 mV.
- **Maximum output value** (defines the maximum value of the analogue output): from 1000 mV to 10200 mV in steps of 100 mV.
- **Power-on duration** (defines the device power-on time, after which it switches off): it is used as a stair lights function.
- **Maximum power-on ramp value** (this is the value reached by brightness at the end of the power-on ramp): from 0% to 100% with default value 0%. N.B: with a value of 0% the brightness value assumes the value of the last power-on done.
- **Minimum power-on ramp value** (this is the instantaneous brightness value upon power-on of the load before beginning the power-on ramp): from 0% to 100% with default value 25%. N.B: the minimum value should be less than the maximum value and more than the minimum adjustment value.
- **Power-on duration** (this is the duration of the power-on ramp, therefore from the minimum value of the power-on ramp to the maximum value of the power-on ramp): from 100 ms to 1h and 48min with default value 2 s.
- **Power-down duration** (this is the duration of the power-down ramp, therefore from the maximum value of the power-on ramp to the minimum value of the power-on ramp): from 100 ms to 1h and 48min with default value 2 s.
- **Power-down delay** (delay times that can be set for actuating the Off request): from 0s to 1h and 48min with default value 0s.
- **Progressive power-down** (indicates the percentage decrease to take the load, starting with the current status, upon arrival of an off control and with a power-down delay other than 0): default value 50%.
- **Operation** (this allows you to set the operation of the actuator): monostable/bistable with default value "two position stable". This parameter is only paired with the proportional actuator unit.
- **Transition duration following absolute value request** (this is the time set to reach a brightness level following a request for absolute value): from 100 ms to 1h and 48min with default value 2s.
- **Output status at power-on and output status at power-down** (this allows you to set the status of the output when switching off and when power is restored respectively): ON/OFF/Unchanged with default value "Unchanged".



CLIMATE CONTROL FUNCTION PROPORTIONAL ACTUATOR (only for art. 30489-01489)

- **Off status value** (defines the value of the output when the dimmer is off): 0 V, minimum, maximum.
- **Minimum output value** (defines the minimum value of the analogue output): from 0.0 mV to 9600 mV in steps of 100 mV.
- **Maximum output value** (defines the maximum value of the analogue output): from 1000 mV to 10200 mV in steps of 100 mV.
- **Inversion** (allows you to set the type, Direct or Reversed, of the control): values 0 and 1.
0=Direct, i.e. as the %value increases, so does the value of the output voltage (0%= min, 100%=max).
1=Reversed, i.e. as the %value decreases, so does the value of the output voltage (0%= max, 100%= min).

6. ACTUATORS

6.1 Devices

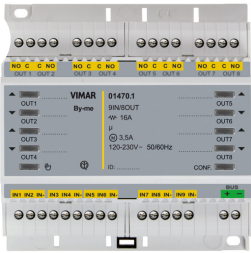
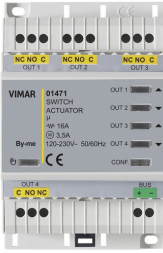
The actuators are as follows:

	<p>01470.1: Module with 9 inputs and 8 preprogrammed outputs for residential or hotel applications, programmable digital inputs for potential-free contacts, N/O relay outputs 16 A 120-230 V~ 50/60 Hz programmable with control function for lights, roller shutters with slat orientation, push-buttons for local control, By-me home automation system, installation on DIN rails (60715 TH35), occupies 6 modules size 17.5 mm.</p>
	<p>01471: Actuator with 4 change-over relay output 16 A 120-230 V~, programmable with control function for lights, roller shutters with slat orientation, fan coil, push buttons for local control, By-me home automation system, installation on DIN rails (60715 TH35), occupies 4 modules size 17.5 mm.</p>
	<p>01417: Actuator and RGB(W) dimmer, 4 PWM outputs up to 5 A 12-48 VDC with constant voltage control, brightness control of max. 4 monochrome LEDs or RGB(W) LED strips or spotlights or Dynamic White LED strips or spotlights, 1 NO relay output 6 A 120-240 V~ for LED power supply units, push buttons for local control, By-me home automation, installation on DIN rail (60715 TH35), occupies 4 modules size 17.5 mm.</p>
	<p>01418: Universal phase cutting dimmer 120-240 V~ 50/60 Hz, 2 outputs for incandescent lamps 40-300 W at 240 V~, 20-150 W at 120 V~, electronic transformers 40-300 VA at 240 V~, 20-150 VA at 120 V~, CFL lamps 10-200 W at 240 V~, 5-100 W at 120 V~, LED lamps 3-200 W at 240 V~, 3-100 W at 120 V~, push buttons for local control, By-me home automation system, protection fuse, installation on DIN rails (60715 TH35), occupies 4 modules size 17.5 mm.</p>

6.2 Functional units of art. 01470.1

Description of functional units

PUSH BUTTON

- Push button: to send ON and OFF messages over the bus as described in the "input behaviour" parameter. It is only with this functional unit that traditional switches can be connected, in addition to push buttons.
- Dimmer control: to control dimmer actuators.
- Roller shutter control: to control the functional unit of shutters with no slats (as each control is the opposite of the previous one, at each long press of the push button, the movement of the roller shutter changes between up and down).
- Timed only control*: to activate a timer
- Timed* and ON/OFF control: to activate a timer and send an ON/OFF control, depending on how long the push button is pressed (for example, short press for timed and long press for ON/OFF).
- Scenario control: to call up and save a scenario.
- Send value: to send the value selected during configuration on the closure of the input.
- Sleep: to call up the sleep function in the sound system.
- Audio monitoring: audio monitoring control (if paired with a microphone module).

Actuators

ROCKER BUTTON

Two inputs need to be used to carry out this function.

- **Rocker button:** to send ON and OFF controls on the same group when pressing input 1 or 2.
- **Dimmer control:** to control dimmer actuators.
- **Roller shutter control:** to control the roller shutter functional unit (normal or with slats).
- **Timed only control*:** to activate a timer
- **Timed* and ON/OFF control:** to activate a timer and send an ON/OFF control, depending on how long the push button is pressed (for example, short press for timed and long press for ON/OFF).
- **Volume OnOff:** on/off and volume control for the sound system.
- **Sleep:** to call up the sleep function in the sound system.
- **Ch+/Track+:** ch+/track+ control for sound system.

ACTUATOR

- **Actuator:** to manage a lights actuator.
This functional unit receives the following control requests: load on/off, timed load on, scenario save and recall.
- **Timed actuator:** also for the timed management of a lights actuator.
Receives the following control requests: double function of timed load and/or load on/off, scenario save and recall.
- **Circulation pump relay:** to manage the circulation pump.

ROLLER SHUTTER ACTUATOR

- **Roller shutter actuator:** to manage the roller shutter.
- **Slats:** to manage the roller shutter + slat
These functional units receive the following control requests: roller shutter opening/closing, slat rotation, roller shutter height and slat rotation value setting, scenario saving and recall, logic unit forcing.

* Configuration of the timed control is only possible if there is already at least one actuator in the group with a timed function.

6.2.1 Configuration of Module with 9 inputs and 8 outputs 01470.1

Each input can be configured like a push button and the adjacent inputs (IN1+IN2, IN3+IN4, IN5+IN6, IN7+IN8) can be grouped together to act as a rocker button. The relays can be used individually or in pairs (OUT1+OUT2, OUT3+OUT4, OUT5+OUT6, OUT7+OUT8) to carry out the roller shutter outputs; relay 8 can be used for the circulation pump.

Note: Device 01470.1 does not carry out the fan coil function.

FUNCTIONAL UNITS

- For each individual relay, the following functional unit can be selected:
 - actuator
 - timed actuator
- For pairs of relays (relay 1+ relay 2, relay 3 + relay 4, relay 5 + relay 6, relay 7 + relay 8), one of the following functional units can be selected:
 - roller shutter actuator
 - slats actuator

Caution: after the functional unit configuration, you need to open and close each roller shutter completely to carry out the calibration process.
- For relay 8 the following functional following unit can be selected:
 - circulation pump relay
- For the push button logic function, one of the following functional units can be selected:
 - push button
 - dimmer control
 - roller shutter control
 - timed only control*
 - timed* and ON/OFF control
 - scenario control
 - send value
 - sleep (control for sound system)
 - audio monitoring (control for sound system)
- For the rocker button logic function (input 1+2, input 3+4, input 5+6, input 7+8) one of the following functional units can be selected (connect a double push button such as art. 20066-19066-14066 and art. 20062-19062-14062):
 - rocker button
 - dimmer control
 - roller shutter control
 - timed only control*
 - timed* and ON/OFF control
 - Volume On/Off (volume control for sound system)
 - sleep (control for sound system)
 - ch+/track+ (control for sound system)

* Configuration of the timed control is only possible if there is already at least one actuator in the group with a timed function.

Actuators

6.3 Parameters of art. 01470.1

Device parameters can be set and/or modified in order to customise their functions and adapt the system to the various installation requirements.

6.4.1 Functional units and their parameters

Description of parameters

ACTUATOR AND TIMED ACTUATOR

- **On delay and off delay** (they are delay times that can be set for actuating the On and Off request): from 0 s to 12 h with default value 0 s.
- **On time duration for one-position stable operation** (this is the activation time for one-position stable operation): from 1 s to 12 h with default value 30 s.
- **Warning time** (this is a time that is added to the activation time of the one-position stable actuator. At the end of the activation time the relay switches off for 0.5 s and then switches back on for the warning time): from 0 s to 12 h with default value 0 s.
- **Output status at power-on and output status at power-down** (this allows you to set the status of the actuator when switching off and when power is restored respectively): ON/OFF/Unchanged with default value "Unchanged".
- **Operation** (this allows you to set the operation of the actuator): monostable/bistable with default value "two position stable" (this parameter is not present for the timed actuator functional unit).

ROLLER SHUTTER AND SLAT ACTUATOR

- **Rise and fall time** (these are the roller shutter raising and lowering times): 10 s to 1 h with default value 180 s.
- **Full slat rotation time**: from 500 ms to 5 s with default value 2 s.
- **Behaviour at power-on** (allows you to set whether when power is restored the roller shutter opens, closes, remains in the current position or you can choose the height of the roller shutter and the tilt of the slats): all down, all up, no action, default position. Default value no "action".
- **Roller shutter position at power-on** (allows you to set the position of the roller shutter when power is restored): from 0 to 100% with default value 50%.
- **Scenario recall execution delay** (allows you to delay execution of the control so as not to actuate all the roller shutters at once): from 0 s to 250 s with default value 0 s.
- **Control execution delay**: from 0 s to 250 s with default value 0 s.
- **Tilt of slats at power-on** (allows you to set the position of the slat when power is restored): from 0 to 100% with default value 50%.
- **Position on forcing** (allows you to set the behaviour of the roller shutter upon the forcing request): all down, all up, fixed, preset position with default value "fixed". It is necessary to observe the value set by the "roller shutter position on forcing" and "slat tilt on forcing" parameters.
- **Position on end of forcing** (allows you to set the behaviour of the roller shutter at the end of forcing): all down, all up, fixed, preset position with default value "fixed". It is necessary to observe the value set by the "roller shutter position on forcing" and "slat tilt on forcing" parameters; it returns to the previous value with the request for forcing.
- **Roller shutter position on forcing** (can be used in the "position on forcing" and "position on end of forcing" parameters): from 0 to 100% with default value 50%.
- **Slat tilt on forcing** (can be used in the "position on forcing" and "position on end of forcing" parameters): from 0 to 100% with default value 50%.

PUSH BUTTON AND ROCKER BUTTON

- **Control input report**: normal push button **ON on closing, OFF on opening**, reversed push button **OFF on closing, ON on opening**, toggle on rising edge, toggle on both edges (to be used when a traditional switch is connected to the input), only **ON ON on closing, only OFF OFF on closing**. Default value "Toggle on the rising edge".
- **Enable scenario saving** (this parameter is for the scenario recall push button that allows you to choose whether, with a long press, the push button sends a request to save the current scenario). Default value "Disabled".
- **Long press time**: from 0.5 ms to 30 s with default value 0.5 s.
- **Short/long press behaviour**: normal or reversed with default value "normal". This parameter is also useful in the case of actuators with a timed function to invert the two ON/OFF and timer controls.
- **Up/Down Orientation**:
 - (ON on input 1 closing and OFF on input 2 closing or vice-versa).
 - only valid for the dimmer control (ON and up adjustment on input 1 closing and OFF and down adjustment on input 2 closing or vice-versa).
 - only valid for the roller shutter push button (roller shutter up on input 1 long closing and roller shutter down on input 2 long closing or vice-versa).
 - ch+ on input 1 closing and track+ on input 2 closing or vice-versa.
- **Output value** (when the input is closed the value chosen with this parameter is sent): from 0 to 100% with default value 0%.
- **LED management**:
 - For the push button, for the dimmer control push button, for the sleep and audio monitoring push button: Normal=LED on if paired load active and off if load deactivated; Reversed=LED off if paired load active and on if load deactivated; always on; Disabled = always off.
 - For the roller shutter push button, for the scenario control push button and for the send value push button: Normal=LED on for 3 s on input closing; Reversed=LED off for 3 s on input closing; always on; Disabled= always off.
 - For the rocker button, for the dimmer control rocker button, for the sleep and ch+/track+ rocker button: Normal=output 1 LED on if paired load active and off if load deactivated; Reversed=output 1 LED off if paired load active and on if load deactivated; always on; Disabled = always off. In the cases of Normal and Reversed, output 2 LED is reversed with respect to output 1
 - For the roller shutter rocker button: Normal=output 1 LED on for 3 s on input 1 closing; Reversed=output 1 LED off for 3 s on input 1 closing; always on; Disabled= always off.

N.B.: For the rocker button, in the event that a single LED is used, the latter needs to be connected to both outputs to have the closing feedback of both inputs.

CIRCULATION PUMP

- **On delay**: default value 0 s.
- **Off delay**: default value 0 s.
- **Valve control** (allows you to select whether to control the valve for heat or the one for cold). Default value "heating valve".

Actuators

<i>Parameter</i>	<i>Functional units</i>								
	Push Button	Roller shutter and dimmer control push button	Timed push button	Scenario control	Send value	Sleep and audio monitoring push button	Rocker button, sleep and ch+/track+ rocker button	Dimmer control rocker button, Volume On/Off and roller shutter	Timed rocker button
Control input report	✓								
Enable scenario saving				✓					
Long/short press behaviour			✓						✓
Long press time		✓	✓	✓				✓	✓
Output value					✓				
Rocker button orientation							✓	✓	
Operation*							✓	✓	

* The "Operation" parameter can only be used in the presence of a sound system (so for the sleep, ch+/track+, Volume On/Off functional units).

<i>Parameter</i>	<i>Functional units</i>				
	Actuator	Timed actuator	Roller shutter actuator	Slats actuator	Circulation pump
ON delay and OFF delay	✓	✓			✓
ON time duration for one-position stable operation	✓	✓			
Warning time	✓	✓			
Output status at power-on and at power-down	✓	✓			
Operation	✓				
Rise and fall time			✓	✓	
Full slat rotation time				✓	
Scenario control execution delay			✓	✓	
Controls execution delay			✓	✓	
Behaviour at power-on			✓	✓	
Roller shutter position at power-on			✓	✓	
Tilt of slats at power-on				✓	
Position on forcing			✓	✓	
Position on end of forcing			✓	✓	
Roller shutter position on forcing			✓	✓	
Slat tilt on forcing				✓	
Valve control					✓

Actuators

6.4 Functional units of art. 01471.

The functional units that the device makes available are as follows: 4 relays or 2 relays + 1 roller shutter or 2 roller shutters or 1 fan coil.

Description of functional units

ACTUATOR

- Actuator: to manage a lights actuator.

This functional unit receives the following control requests: load on/off, timed load on, scenario save and recall.

- Timed actuator: also for the timed management of a lights actuator.

Receives the following control requests: double function of timed load and/or load on/off, scenario save and recall.

ROLLER SHUTTER ACTUATOR

- Roller shutter actuator: to manage the roller shutter.
- Slats: to manage the roller shutter + slat

These functional units receive the following control requests: roller shutter opening/closing, slat rotation, roller shutter height and slat rotation value setting, scenario saving and recall, logic module forcing.

FAN COIL

- 2- or 4-pipe Fan coil or integrations with third parties

Functional units

- For each individual relay, the following functional unit can be selected:

- actuator
- timed actuator

- For pairs of relays (relay 1+ relay 2 or relay 3 + relay 4), one of the following functional units can be selected:

- roller shutter actuator
- slats actuator

Caution: after installation you need to open and close each roller shutter completely to carry out the calibration process.

- For the 4 relays used in a single unit, one of the following functional units can be selected:

- 2/4-pipe fan coil: the App automatically selects the functional unit according to the configuration of the thermostat already present in the group.
- third-party integration fan coil: controlled by devices which send a proportional value (for example art. 02951).

6.5 Parameters of art. 01471.

Device parameters can be set and/or modified in order to customise their functions and adapt the system to the various installation requirements.

6.5.1 Functional units and their parameters

Description of parameters

ACTUATOR AND TIMED ACTUATOR

- On delay and off delay (they are delay times that can be set for actuating the On and Off request): from 0 s to 12 h with default value 0 s.
- On time duration for one-position stable operation (this is the activation time for one-position stable operation): from 1 s to 12 h with default value 30 s.
- Warning time (this is a time that is added to the activation time of the one-position stable actuator. At the end of the activation time the relay switches off for 0.5 s and then switches back on for the warning time): from 0 s to 12 h with default value 0 s.
- Output status at power-on and output status at power-down (this allows you to set the status of the actuator when switching off and when power is restored respectively): ON/OFF/Unchanged with default value "Unchanged".
- Operation (this allows you to set the operation of the actuator): monostable/bistable with default value "two position stable" (this parameter is not present for the timed actuator functional unit).

ROLLER SHUTTER AND SLAT ACTUATOR

- Rise and fall time (these are the roller shutter raising and lowering times): 10 s to 1 h with default value 180 s.
- Full slat rotation time: from 500 ms to 5 s with default value 2 s.
- Behaviour at power-on (allows you to set whether when power is restored the roller shutter opens, closes, remains in the current position or you can choose the height of the roller shutter and the tilt of the slats): all down, all up, no action, default position. Default value no "action".
- Roller shutter position at power-on (allows you to set the position of the roller shutter when power is restored): from 0 to 100% with default value 50%.
- Scenario recall execution delay (allows you to delay execution of the control so as not to actuate all the roller shutters at once): from 0 s to 250 s with default value 0 s.
- Control execution delay: from 0 s to 250 s with default value 0 s.
- Tilt of slats at power-on (allows you to set the position of the slat when power is restored): from 0 to 100% with default value 50%.
- Position on forcing (allows you to set the behaviour of the roller shutter upon the forcing request): all down, all up, fixed, preset position with default value "fixed". It is necessary to observe the value set by the "roller shutter position on forcing" and "slat tilt on forcing" parameters.
- Position on end of forcing (allows you to set the behaviour of the roller shutter at the end of forcing): all down, all up, fixed, preset position with default value "fixed". It is necessary to observe the value set by the "roller shutter position on forcing" and "slat tilt on forcing" parameters; it returns to the previous value with the request for forcing.
- Roller shutter position on forcing (can be used in the "position on forcing" and "position on end of forcing" parameters): from 0 to 100% with default value 50%.
- Slat tilt on forcing (can be used in the "position on forcing" and "position on end of forcing" parameters): from 0 to 100% with default value 50%.

FAN COIL

- Valve control (allows you to select whether to control the valve for heat or the one for cold). Default value "heating valve". This parameter is only valid in the case of a 4-pipe configuration.

Actuators

6.6 Functional units of art. 01418.

Description of functional units

DIMMER ACTUATOR

- Actuator: to manage an actuator for light control.
Receives the following control requests: load on/off/control.
- Timed actuator: to manage an actuator for light control with a timer.
Receives the following control requests: load on/off/control.

6.6.1 Configuration of art. 01418

FUNCTIONAL UNITS

- For the actuator output, one of the following functional units can be selected:
 - dimmer actuator
 - timed dimmer actuator

6.7 Parameters of art. 01418

Device parameters can be set and/or modified in order to customise their functions and adapt the system to the various installation requirements.

Functional units and their parameters

Description of parameters

DIMMER ACTUATOR AND TIMED DIMMER ACTUATOR

- Dimming speed (allows you to select the dimming speed): minimum, normal, maximum with default normal.
- Phase cutting (allows you to select the phase cutting according to the load connected): LE (leading edge), TE (trailing edge) with default LE.

Dimming with leading edge LE phase control

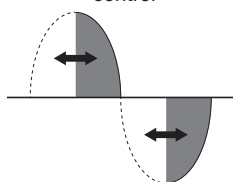

Dimming with trailing edge TE phase control

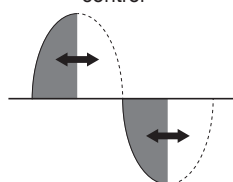

- Minimum adjustment value (defines the minimum brightness percentage during operation): from 15% to 50% with default value 25%.

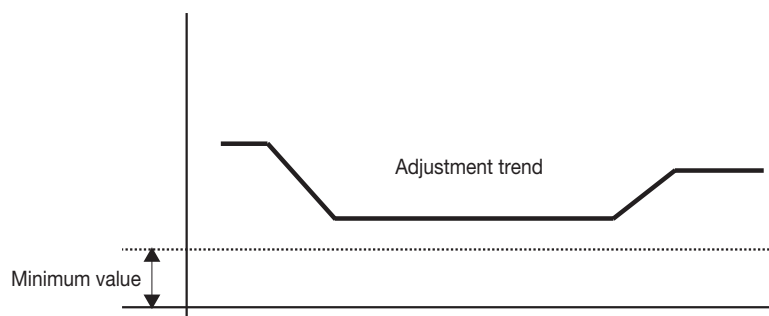

- Flash start (allows you to select possible impulsive lamp lighting): active/not active with default value not active.

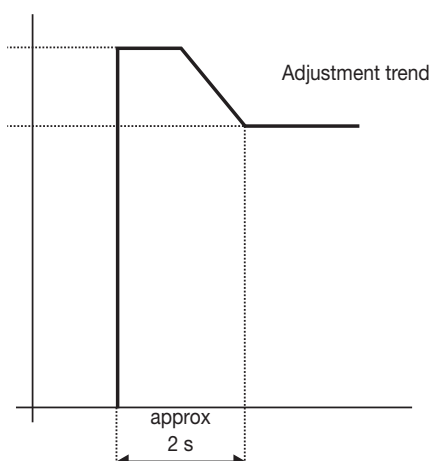

Actuators

- **On time duration for one-position stable operation** (this is the activation time for one-position stable operation): from 100 ms to 1h and 48min with default value 1 min.
- **Maximum power-on ramp value** (this is the value reached by brightness at the end of the power-on ramp): from 0% to 100% with default value 0%. N.B: with a value of 0% the brightness value assumes the value of the last power-on done.
- **Minimum power-on ramp value** (this is the instantaneous brightness value upon power-on of the load before beginning the power-on ramp): from 0% to 100% with default value 25%. N.B: the minimum value should be less than the maximum value and more than the minimum adjustment value.
- **Power-on duration** (this is the duration of the power-on ramp, therefore from the minimum value of the power-on ramp to the maximum value of the power-on ramp): from 100 ms to 1h and 48min with default value 2 s.
- **Power-down duration** (this is the duration of the power-down ramp, therefore from the maximum value of the power-on ramp to the minimum value of the power-on ramp): from 100 ms to 1h and 48min with default value 2 s.

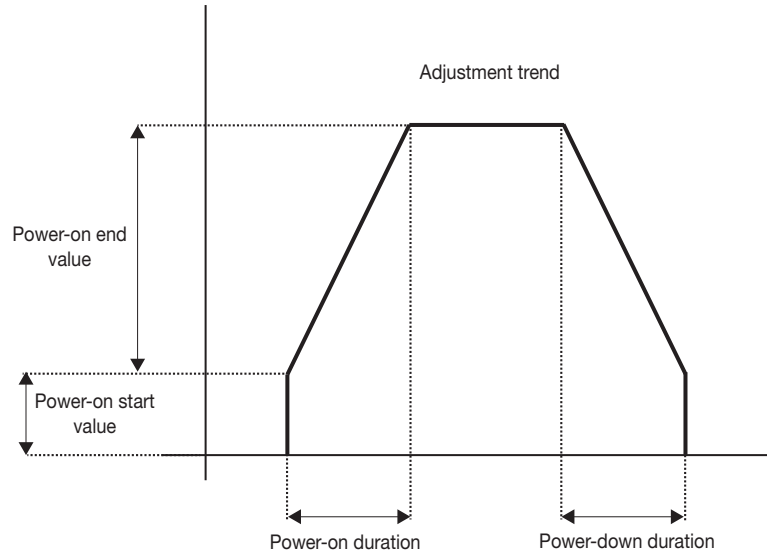

- **Power-down delay** (delay times that can be set for actuating the Off request): from 0s to 1h and 48min with default value 0s.

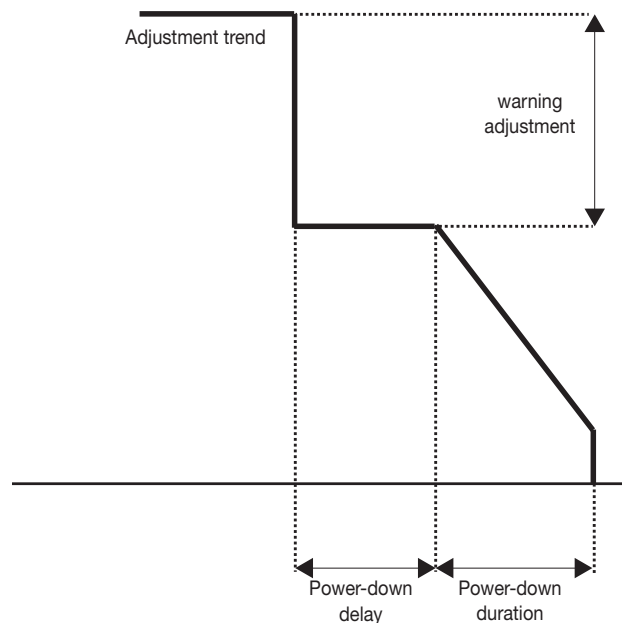

- **Transition duration following absolute value request** (this is the time set to reach a brightness level following a request for absolute value): from 100 ms to 1h and 48min with default value 2s.

Actuators

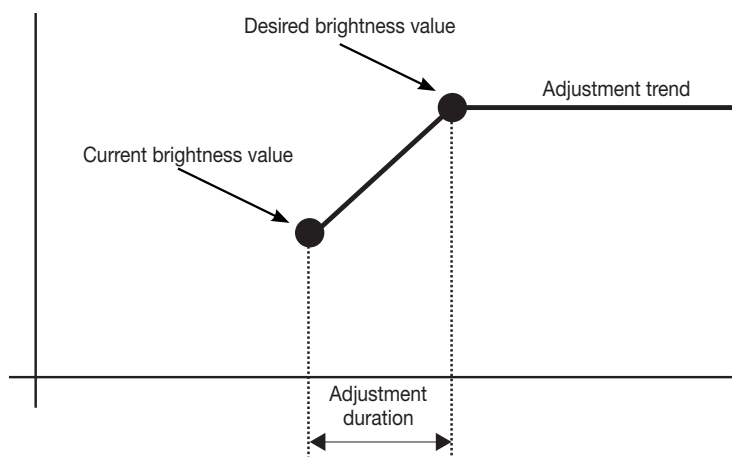

- **Operation** (this allows you to set the operation of the actuator): monostable/bistable with default value “two position stable” (this parameter is not present for the timed white dimmer functional unit).
- **Output status at power-on and output status at power-down** (this allows you to set the status of the output when switching off and when power is restored respectively): ON/OFF/Unchanged with default value “Unchanged”.

6.8 The actuator and dimmer art. 01417

The RGB(W) actuator and dimmer is designed to adjust the brightness of RGB(W), dynamic white or monochrome LED strips while also guaranteeing all the classic home automation functions of By-me actuators.

The device is powered in direct voltage (VDC) by the bus line and is fitted with 4 amber front LEDs which indicate the status of the outputs, 4 front buttons to test the outputs, 1 red LED to signal any anomalies, 1 relay contact to pilot the mains voltage of the auxiliary power supply unit of the LEDs and 4 independent output channels.

The device relay can be used to interrupt the phase of the power supply unit connected to the input terminals of the dimmer actuator; this way, when all the channels are off, the dimmer opens the relay thereby interrupting the phase of the power supply unit and thus retaining its functionality for as long as possible.

The relay operation is integrated into the functional units and there are therefore no parameters that define its behaviour.

The relay is closed when one or more channels are activated, and it opens when all the channels are off.

6.8.1 Functioning

The RGB(W) dimmer and actuator is configured on the home automation Gateway art. 01410-01411 via the View Pro App and it is designed to perform the following functions:

- **ON/OFF switching**
Upon receipt of the ON/OFF controls, the device activates the last brightness value stored or deactivates (0%) the corresponding channel.
- **Relative brightness control (White)**
Allows you to increase or decrease the brightness value of the channel according to the controls received from other By-me devices. Upon receipt of a stop control, the control stops and the brightness value reached at that moment is maintained.
- **Absolute brightness control (White)**
Allows you to set the absolute brightness percentage value defined by the control received; this value is reached via a ramp.
- **Relative RGB(W) colour control**
When the device is configured to control an RGB(W) LED strip, the shade, saturation and brightness values can be increased or decreased independently.
- **Absolute RGB(W) colour control**
When the device is configured to control an RGB(W) LED strip, the absolute RGB coordinate can be set. The transition occurs via a ramp, the duration of which can be configured.
- **Dynamic control of “Dynamic White” white**
The dynamic white technology makes it possible to adjust the colour temperature of the white light between 2,500 K and 7,000 K. The device in dynamic white mode simulates natural daylight, adapting to the setting and to personal taste.
- **Timed switching (Staircase Light)**
The device activates the channel corresponding to the last brightness value stored for the time set on the “PAR_TimeOnDuration” parameter and deactivates it (brightness value 0%) when the time expires (not available in RGB(W) mode).

6.9 Functional units of art. 01417.

The device is equipped with 4 output contacts with which up to 4 monochrome LEDs can be operated independently or a RGBW channel or a Dynamic White channel can be controlled.

In the event of a monochrome LED, outputs 1 and 2 can also be parallelized.

For dynamic white, outputs 1 (cold white) and 2 (warm white) can be used, or 3 (cold white) and 4 (warm white).

Description of functional units

- **Monochrome LED:** Dimmer (1-R), Dimmer (2-G), Dimmer (3-B), Dimmer (4-W), Dimmer (1-R + 2-G) functional units
- **Dynamic white LED:** Dynamic white dimmer (1-R + 2-G), Dynamic white dimmer (3-B + 4-W) functional units
- **RGBW LED:** RGB/RGBW dimmer (1-R + 2-G + 3-B + 4-W) functional unit

Actuators

6.10 Parameters of art. 01417.

Device parameters can be set and/or modified in order to customise their functions and adapt the system to the various installation requirements.

6.10.1 Functional units and their parameters

DIMMER

- **Dimmer operation:** defines the active behaviour of the DIMMER functional unit
Settable values: RGB dimmer; RGBW dimmer.
- **Dimming speed:** defines the dimming speed of the output.
Settable values: low; medium; high.
- **Minimum value:** defines the minimum dimming value admitted during operation (1-100%).
Settable values: from 1 to 100% with default value of 1%.
- **ON duration:** defines the time for which the device is on; at the end of this time, the device switches off and sends the information on its status.
Settable values: from 00:01 59:59 (00:10 steps) with default value of 00:20.
- **Power-on final value:** defines the highest value of the dimming ramp.
Unless specified (=0), the value of the last power-on made is set.
If the power-on final value parameter is below the power-on start value, the latter will be the final dimming ramp value.
Settable values: from 0 to 100%.
- **Power-on start value:** defines the lowest value of the dimming ramp.
If the power-on start value parameter is less than the minimum value the device ignores it.
If the power-on start value is greater than the power-on final value the device will use the power-on start value as the final dimming ramp value.
Settable values: from 0 to 100%.
- **Power-on duration:** defines the duration of the power-on dimming ramp from the value set as the power-on start value to the value set as the power-on final value.
If equal to 0 the dimming ramp time will be that envisaged by the hardware.
Settable values [minutes:seconds]: 00:00 59:59 (00:10 steps) with default value of 00:20.
- **Power-down duration:** defines the duration of the power-down dimming ramp from the value set as the power-on final value to the value set as the power-on start value.
Settable values [minutes:seconds]: 00:00 59:59 (00:10 steps) with default value of 00:20.
- **Power-down delay:** defines the power-down delay of the lamp following the receipt of an OFF message.
Settable values [minutes:seconds]: 00:00 59:59 (00:10 steps) with default value of 00:20.
- **Warning adjustment:** defines, on arrival of an OFF message when the Power-down delay parameter is other than zero, the percentage decrease to adjust the load starting with the current status.
If the value to adjust the load (obtained from the difference between the current value and the warning adjustment value) is less than that of the minimum value, the load is adjusted to the minimum value.
Settable values: from 0 to 100% with default value of 50%.
- **Dimmer behaviour:** defines the one-position stable or two-position stable behaviour of the dimmer.
Settable values: one-position stable, two-position stable.
- **Adjustment duration:** defines the transition time from the current colour to the one set as the absolute value.
Settable values [minutes:seconds]: 00:00 59:59 (00:10 steps) with default value of 00:20.
- **Output status at power-on:** defines the behaviour of the RGBW actuator when the mains voltage is restored.
Settable values: OFF (the load is set to OFF upon power-on); ON (the load is set to ON upon power-on); unchanged (the load remains in its current position upon power-on).
- **PWM frequency for all channels:** defines the frequency with which an adjustment cycle is completed.
Settable values: 400 Hz; 260 Hz; 200 Hz with default value of 0.

DYNAMIC WHITE DIMMER

The parameters are the same as the WHITE DIMMER functional unit, with the addition of those described below.

- **Dimmer operation:** defines the active behaviour of the DYNAMIC WHITE DIMMER functional unit
Settable values: Dynamic white dimmer; Timed dynamic white dimmer.
- **Colour temperature control speed:** defines the speed of control of the mixing level between warm white and cold white of the output.
Settable values for the ramp speed: low; medium, high.
- **Colour temperature control duration:** defines the transition time from the current mixing value between warm white and cold white and that set as the absolute value.
Settable values [minutes:seconds]: 00:00 59:59 (00:10 steps) with default value of 00:20.

RGB/RGBW DIMMER

The parameters are the same as the WHITE DIMMER functional unit, with the addition of those described below.

- **Colour transition mode:** defines the method of use of the white channel in RGBW operation.
Settable values: mode 1; mode 2; mode 3; mode 4.
- **White channel use level:** designed to select several mixing logics of the white channel to adapt to the various types of LED strips on the market.
Settable values: minimum; medium; maximum.
- **Fading Show persistence duration:** defines the persistence time for each of the colours set for operation in "fading show".
Settable values [minutes:seconds]: 00:00 59:59 (00:10 steps) with default value of 00:20.
- **Fading Show transition duration:** defines the transition time between one colour and the next during operation in "fading show".
Settable values [minutes:seconds]: 00:00 59:59 (00:10 steps) with default value of 00:20.
- **Fading Show colour:** defines the matrix of 6 colours in RGB coordinates that describe the curve reproduced during operation in "fading show".
If the value of the colour coordinate is BLACK the colour set is ignored during transition.
Settable values: R from 0 to 255; G from 0 to 255; B from 0 to 255 (R:1, G:1, B:1 step).

Actuators

6.11 The DALI/DALI-2 lamp actuator

The actuator is used to connect and manage up to 64 DALI/DALI-2 channels (e.g. dimmers, transformers, etc.). With 16 independent functional units to which up to 64 DALI/DALI-2 channels can be associated.

The device has 3 LEDs on the front indicating the operating state and 2 front buttons; CONF allows you to enrol the device in the By-me Plus system and DALI performs the lamps test and enables/disables the manual function.

6.11.1 Function

The DALI/DALI-2 actuator is configured on the home automation system Gateway art. 01410-01411 via the VIEW Pro App and it is designed to perform the following functions:

- **ON/OFF lamp**
 - Upon receipt of ON/OFF controls, the device turns the controlled lamp on/off.
- **Monochrome lamp**
 - Upon receipt of the ON/OFF controls, the device activates the last brightness value stored or deactivates (0%) the corresponding channel.
 - Allows you to increase or decrease the brightness value of the channel according to the controls received from other By-me devices. Upon receipt of a stop control, the control stops and the brightness value reached at that moment is maintained.
 - If set to one-position stable, allows you to define the absolute brightness percentage value defined by the control received; this value is reached via a ramp.
- **Tunable White lamp**
 - Upon receipt of the ON/OFF controls, the device activates the last brightness value stored or deactivates (0%) the corresponding channel.
 - Allows you to increase or decrease the brightness value of the channel according to the controls received from other By-me devices. Upon receipt of a stop control, the control stops and the brightness value reached at that moment is maintained.
 - If set to one-position stable, allows you to define the absolute brightness percentage value defined by the control received; this value is reached via a ramp.
 - The tunable white technology makes it possible to adjust the colour temperature of the white light within a range of values that can be set using the respective parameters. In tunable white mode, the device simulates natural light, adapting it to the environment and to personal taste.
 - For better output from the adjustment, actuator 01419.1 sets a linear curve; if the DALI dimmer is not fitted with this mode, refer to the dimmer manufacturer's documentation to optimise the adjustment curve.
- **RGB/ RGBW lamp**
 - Upon receipt of the ON/OFF controls, the device activates the last colour value stored or deactivates (0%) the corresponding channel.
 - When the device is configured to control an RGB(W) LED strip, the absolute RGB coordinate can be set. The transition occurs via a ramp, the duration of which can be configured.
 - If set to one-position stable, allows you to define the absolute brightness percentage value defined by the control received; this value is reached via a ramp.

6.11.2 Parameters

ON/OFF LAMP

- **ON duration:** defines the time for which the device is on; at the end of this time, the device switches off and sends the information on its status.
Settable values [minutes:seconds]: from 00:01 to 59:59 (00:01 steps) with default value of 01:00.
- **Power-down delay:** defines the power-down delay of the lamp following the receipt of an OFF message.
Settable values [minutes:seconds]: from 00:00 to 59:59 (00:01 steps) with default value of 00:00.
- **Dimmer behaviour:** defines the one-position stable or two-position stable behaviour of the dimmer.
Settable values: one-position stable, two-position stable.
- **DALI bus return output status:** defines the behaviour of the device when the voltage is restored on the DALI bus.
Settable values: OFF (when restored, the load is set to OFF); ON (when restored, the load is set to ON); UNCHANGED (when restored, the load remains in its current position).
- **DALI bus fault output status:** defines the behaviour of the device during the fault status on the DALI bus; this parameter has no effect on the DALI devices that are powered solely by the bus.
Settable values: OFF (when restored, the load is set to OFF); ON (when restored, the load is set to ON); UNCHANGED (when restored, the load remains in its current position).

MONOCHROME LAMP

- **Dimming speed:** defines the dimming speed at the output during the related control from the buttons.
Settable values: low; medium; high.
- **ON duration:** defines the time for which the device is on; at the end of this time, the device switches off and sends the information on its status.
Settable values [minutes:seconds]: from 00:01 to 59:59 (00:01 steps) with default value of 01:00.
- **Minimum value:** defines the minimum dimming value permitted (as specified by the DALI device manufacturer) during operation (0-80%).
Settable values: from 0 to 80% with default value of 10%.
- **Power-on final value:** defines the highest value of the dimming ramp.
Unless specified (=0), the value of the last power-on made is set.
If the power-on final value parameter is below the power-on start value, the latter will be the final dimming ramp value.
Settable values: from 0 to 100%.
- **Power-on start value:** defines the lowest value of the dimming ramp.
If the power-on start value parameter is less than the minimum value the device ignores it.
If the power-on start value is greater than the power-on final value the device will use the power-on start value as the final dimming ramp value.
Settable values: from 0 to 100%.
- **Ramp time:** unequivocal value that defines the duration of the dimming ramp during power-on, dimming and power-down.
Settable values: 0s, 0.7s, 1s, 1.4s, 2s, 2.8s, 4s, 5.7s, 8s, 11.3s, 16s, 22.6s, 32s, 45.3s, 64s, 90.5s with default value at 2s.
- **Power-down delay:** defines the power-down delay of the lamp following the receipt of an OFF message.
Settable values [minutes:seconds]: from 00:01 to 59:59 (00:01 steps) with default value of 01:00.

Actuators

- **Warning adjustment:** defines, on arrival of an OFF message when the "Power-down delay" parameter is other than zero, the percentage decrease to adjust the load starting with the current status. If the value to adjust the load (obtained from the difference between the current value and the "Warning adjustment" value) is less than that of the "Minimum value", the load is adjusted to the "Minimum value".
Settable values: from 0 to 100% with default value of 50%.
- **Dimmer behaviour:** defines the one-position stable or two-position stable behaviour of the dimmer.
Settable values: one-position stable, two-position stable.
- **DALI bus voltage return dimmer behaviour:** defines the behaviour of the device when the voltage is restored on the DALI bus.
Settable values: Off (when restored, the load is set to Off); Last value (when restored, the load is set to the last value); Specific value (when restored, the load is set to the value indicated by the "DALI bus voltage return value" parameter).
- **DALI bus voltage return value:** Percentage value which the load is set to if the "DALI bus voltage return dimmer behaviour" parameter is set to "Specific value"
Settable values: from 0% to 100% with default of 50%.
- **DALI bus fault dimmer behaviour:** defines the behaviour of the device when during the fault on the DALI bus.
Settable values: Off (the load is set to Off); Last value (the load is set to the last value); Specific value (the load is set to the value indicated by the "DALI bus fault value" parameter).
- **DALI bus fault value:** Percentage value which the load is set to if the "DALI bus fault dimmer behaviour" parameter is set to "Specific value".
Settable values: from 0% to 100% with default of 50%.

TUNABLE WHITE LAMP

- **Dimming speed:** defines the dimming speed at the output during the related control from the buttons.
Settable values: low; medium; high.
- **ON duration:** defines the time for which the device is on; at the end of this time, the device switches off and sends the information on its status.
Settable values [minutes:seconds]: from 00:01 to 59:59 (00:01 steps) with default value of 01:00.
- **Minimum value:** defines the minimum dimming value permitted (as specified by the DALI device manufacturer) during operation (0-80%).
Settable values: from 0 to 80% with default value of 10%.
- **Power-on final value:** defines the highest value of the dimming ramp.
Unless specified (=0), the value of the last power-on made is set.
If the power-on final value parameter is below the power-on start value, the latter will be the final dimming ramp value.
Settable values: from 0 to 100%.
- **Power-on start value:** defines the lowest value of the dimming ramp.
If the power-on start value parameter is less than the minimum value the device ignores it.
If the power-on start value is greater than the power-on final value the device will use the power-on start value as the final dimming ramp value.
Settable values: from 0 to 100%.
- **Ramp time:** unequivocal value that defines the duration of the dimming ramp during power-on, dimming and power-down.
Settable values: 0s, 0.7s, 1s, 1.4s, 2s, 2.8s, 4s, 5.7s, 8s, 11.3s, 16s, 22.6s, 32s, 45.3s, 64s, 90.5s with default value at 2s.
- **Power-down delay:** defines the power-down delay of the lamp following the receipt of an OFF message.
Settable values [minutes:seconds]: from 00:01 to 59:59 (00:01 steps) with default value of 01:00.
- **Warning adjustment:** defines, on arrival of an OFF message when the "Power-down delay" parameter is other than zero, the percentage decrease to adjust the load starting with the current status. If the value to adjust the load (obtained from the difference between the current value and the "Warning adjustment" value) is less than that of the "Minimum value", the load is adjusted to the "Minimum value".
Settable values: from 0 to 100% with default value of 50%.
- **Dimmer behaviour:** defines the one-position stable or two-position stable behaviour of the dimmer.
Settable values: one-position stable, two-position stable.
- **DALI bus voltage return dimmer behaviour:** defines the behaviour of the device when the voltage is restored on the DALI bus.
Settable values: Off (when restored, the load is set to Off); Last value (when restored, the load is set to the last value); Specific value (when restored, the load is set to the value indicated by the "DALI bus voltage return value" parameter).
- **DALI bus voltage return value:** Percentage value which the load is set to if the "DALI bus voltage return dimmer behaviour" parameter is set to "Specific value"
Settable values: from 0% to 100% with default of 50%.
- **DALI bus fault dimmer behaviour:** defines the behaviour of the device when during the fault on the DALI bus.
Settable values: Off (the load is set to Off); Last value (the load is set to the last value); Specific value (the load is set to the value indicated by the "DALI bus fault value" parameter).
- **DALI bus fault value:** Percentage value which the load is set to if the "DALI bus fault dimmer behaviour" parameter is set to "Specific value".
Settable values: from 0% to 100% with default of 50%.
- **Colour temperature - maximum value (K) :** Maximum value (coldest) of the colour temperature related to the connected load. This parameter can only be set if the DALI dimmer is in configuration DT8.
- **Colour temperature - minimum value (K) :** Minimum value (hottest) of the colour temperature related to the connected load. This parameter can only be set if the DALI dimmer is in configuration DT8.

Note: There is no parameter capable of managing the behaviour of the DALI driver in the event of a reactor power outage.

Actuators

RGB/ RGBW LAMP

- **ON duration:** defines the time for which the device is on; at the end of this time, the device switches off and sends the information on its status.
Settable values [minutes:seconds]: from 00:01 to 59:59 (00:01 steps) with default value of 01:00.
- **Minimum value:** defines the minimum dimming value permitted (as specified by the DALI device manufacturer) during operation (0-80%).
Settable values: from 0 to 80% with default value of 10%.
- **Ramp time:** unequivocal value that defines the duration of the dimming ramp during power-on, dimming and power-down.
Settable values: 0s, 0.7s, 1s, 1.4s, 2s, 2.8s, 4s, 5.7s, 8s, 11.3s, 16s, 22.6s, 32s, 45.3s, 64s, 90.5s with default value at 2s.
- **Dimmer behaviour:** defines the one-position stable or two-position stable behaviour of the dimmer.
Settable values: one-position stable, two-position stable.
- **DALI bus voltage return dimmer behaviour:** defines the behaviour of the device when the voltage is restored on the DALI bus.
Settable values: Off (when restored, the load is set to Off); Last value (when restored, the load is set to the last value).
- **DALI bus fault dimmer behaviour:** defines the behaviour of the device when during the fault on the DALI bus.
Settable values: Off (the load is set to Off); Last value (the load is set to the last value).

Sound system

7. SOUND SYSTEM

7.1 General characteristics

The sound system is used to create systems able to transmit a high quality audio signal (CD quality), with up to 4 audio sources in different rooms at the same time. Thanks to the various system devices, integration with all the By-me controls and the range of matching speakers, it is possible to create completely integrated mono or multi-channel systems.

In the various rooms there is total freedom of choice and control and it is possible, thanks to the multi-channels, to transmit different music in different environments.

The possibility of free distribution of the transmitter and receiver nodes and of the controls keeps the wiring simple allowing perfect integration with the controls and actuators of the home automation system.

The range of devices has been extended, both to manage more available audio sources (new *Bluetooth technology* interface and the possibility of adding an unlimited number of local sources) and to increase the power handling capacity (controls with preamplified outputs and new flush-mounting amplifier).

The performance, numerous functions, installation flexibility and above all the quality of the sound make it possible to use the system both in the residential sector (from apartments to villas) and in the small service industry (health centres, shops, cafés, restaurants, supermarkets).

The main characteristics can be summed up in the following points:

1. **2-wire system** (use cable art. 01840.E.B) **with in-out** linear wiring that enables perfect integration with the By-me automation devices (that can be connected to the "audio" branch through a special branch tap-off for By-me devices 01903 or through the special terminal on all the devices of the sound system).
2. **Possibility of using By-me controls** (buttons, touch screens and also the ones connected to the automation line) for system control (switching on/off, volume adjustment, source selection, track or radio station selection, etc.).
3. **Distributed architecture** (therefore with no central node that requires star wiring) that makes it possible to install transmitters and receivers at any point in the system.
4. **4 simultaneous stereo channels**, with CD audio quality.
5. Up to **60 independent audio** zones.
6. Possibility of **using the BUS as an FM antenna** (in this case the auxiliary external antenna is not necessary).
7. Possibility of connecting higher power amplifiers thanks to the LINE OUT output (art. 20590-19590-14590 or third-party amplifiers).
8. In addition to the RCA inputs module and the FM tuner, the *Bluetooth technology* interface is now also available.
9. Possibility of **programming the maximum audio levels** for each zone.
10. Possibility of making **microphone calls**.
11. Audio **monitoring function**.
12. Baby **control function**.
13. **Integration with scenarios** in the By-me Plus system.

7.2 Devices and functions



The sound system is composed of the following categories of devices:

- Transmitter devices
- Receiver devices
- Speakers
- Accessory modules



7.2.1 Transmitter devices

The transmitter devices make it possible to transmit the sound coming from a sound source (e.g. HiFi system, CD player, portable MP3 players, etc..) to the system receivers.

Each transmitter configured in the system occupies one of the 4 channels available, and can be connected to any point of the system.





	<p>20582-19582-14582: Input module with 2 RCA connectors. Galvanic decoupling of the audio inputs to the By-me bus. Flush-mounting 2M mechanism.</p>
	<p>01900: FM radio tuner with RDS on 2 DIN modules. Managed via APP and touch screen, displaying RDS info (tuning, station, track, etc...). 8 tuning memories available. Possibility of using internal antenna (BUS) or external antenna with coaxial connector (type F).</p>

Sound system

	<p>30495-20589-19589-14589: Bluetooth® technology interface for home automation, stores up to 8 mobile devices. Flush-mounting 2M mechanism. The device is a <i>Bluetooth technology</i> interface that acts as a transmitter in the By-me sound system to input the audio from a smartphone or tablet (Android and iOS) on a BUS channel. In addition to transmitting the audio signal to the receiver devices, it is also used to control the smartphone or tablet remotely by sending controls on the Bus.</p>
	<p>20586-19586-14586: Call microphone module Module allowing calls to different services available (2M flush mounting). Front push buttons for activating the call, general or selective, built-in microphone.</p>



7.2.2 Receiver devices

Receiver devices are used to listen to the audio transmitted through one of the channels in the system. These devices are also equipped with a high quality audio amplifier that enables direct connection to the acoustic speakers.



	<p>01483: Home automation control device with four push buttons, 1 LINE OUT output, RGB LED visible in darkness with brightness control, to be completed with interchangeable half-button caps: 1 or 2 module Eikon, 2 module Arké or Plana.</p>
	<p>30484-01484: Home automation control device with four push buttons and 1+1 W RMS stereo amplifier, 2 outputs for 8 ohm speakers, RGB LED visible in darkness with brightness control, to be completed with interchangeable half-button caps: 1 or 2 module Eikon, 2 module Arké or Plana.</p>
	<p>01901: Output module with 10+10W amplifier DIN 6M mechanism. Power supply 110-230V~, 50-60Hz</p>
	<p>20590-19590-14590: 4 + 4 W RMS stereo amplifier, 2 outputs for 8 Ω speakers with built-in Bluetooth technology receiver, 1 LINE IN input, 12 V SELV power supply - 2 modules.</p>

7.2.3 Speakers

The system has a complete range of surface and flush mounting speakers (including versions for ceilings, hollow walls, etc.).



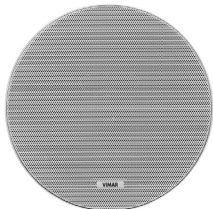

	<p>21588: Passive 4+4M flush mounting speaker, 10W 8Ω</p>
	<p>20587: Passive 3M flush mounting speaker, 3W 8Ω</p>
	<p>01906: Passive IP55 speaker, 30W 8Ω</p>

Sound system

	<p>01907.1: Passive ceiling mounting speaker, 30W 8Ω</p>
	<p>01908: Passive wall mounting speaker, 30W 8Ω</p>

7.2.4 Accessory modules

Accessory modules are devices that, while not having any direct use by the user, are required in the system for its operation or for the various wiring/construction possibilities (see chap.3 and 4).

	<p>01902: Decoupler for By-me power supply unit Decoupling module to be used at the By-me power supply unit output (or at the output of a line coupler). DIN 2M enclosure.</p>
	<p>01903: Branch tap-off module for By-me devices Retrofit enclosure</p>
	<p>01904: Branch tap-off module for Sound system devices Retrofit enclosure.</p>
	<p>20580-19580-14580: Auxiliary 32V power supply unit Power supply 110-230V~, 50-60Hz 32 V DC output, 3W. Flush-mounting 1M mechanism.</p>
	<p>20584-19584-14584: Stereo source control with remote control (not supplied) via cable with IR transmitter (supplied). The device must be paired with an RCA input module.</p>

Sound system

7.3 Installation rules and topology

To construct a sound system, you need to follow a few simple rules which are illustrated in this chapter.

To facilitate installation a coloured BUS cable (blue) has been introduced to identify the part of the system or branches of the bus dedicated to the sound system easily and with no error.

7.3.1 Installation topologies

The sound system lends itself to various constructions according to the needs and dimensions of the system.

Example 1: sound system on the same logical branch (Area/Line) but with separate wiring.

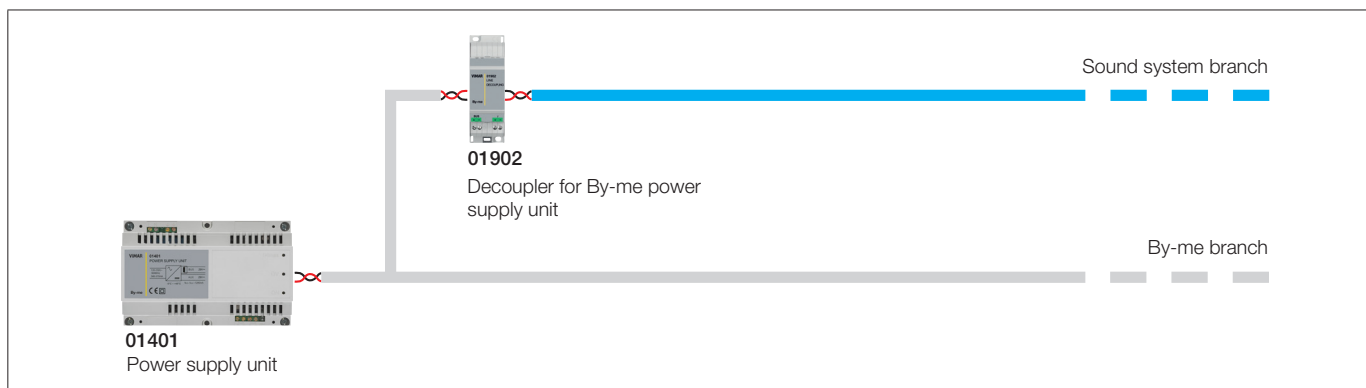

In this case the separation is purely with the wiring and not the logic: the sound system devices and the By-me devices are configured on the same line.

Example 2: dedicated logic branch

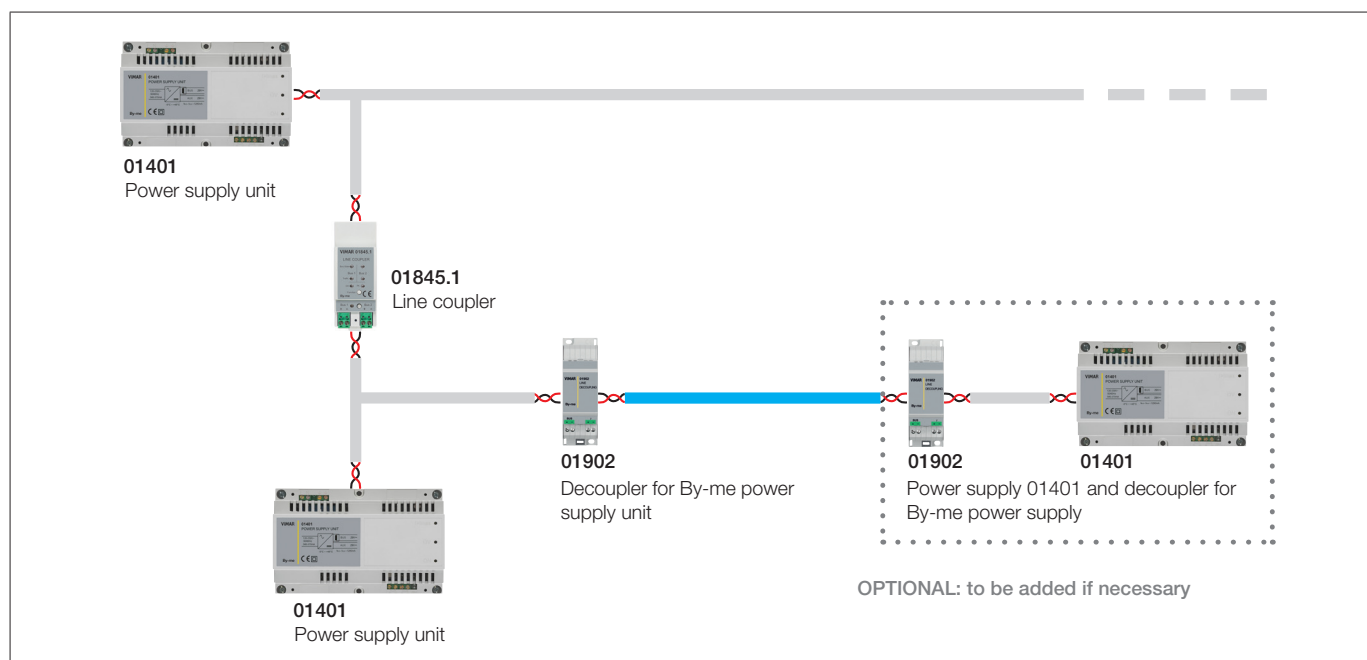

In this case, the sound system devices are configured in a different line from the other By-me devices. The second power supply unit and the dedicated decoupler are optional and must only be included when necessary for reasons of consumption.

Sound system

Example 3: By-me automation and sound system on the same branch

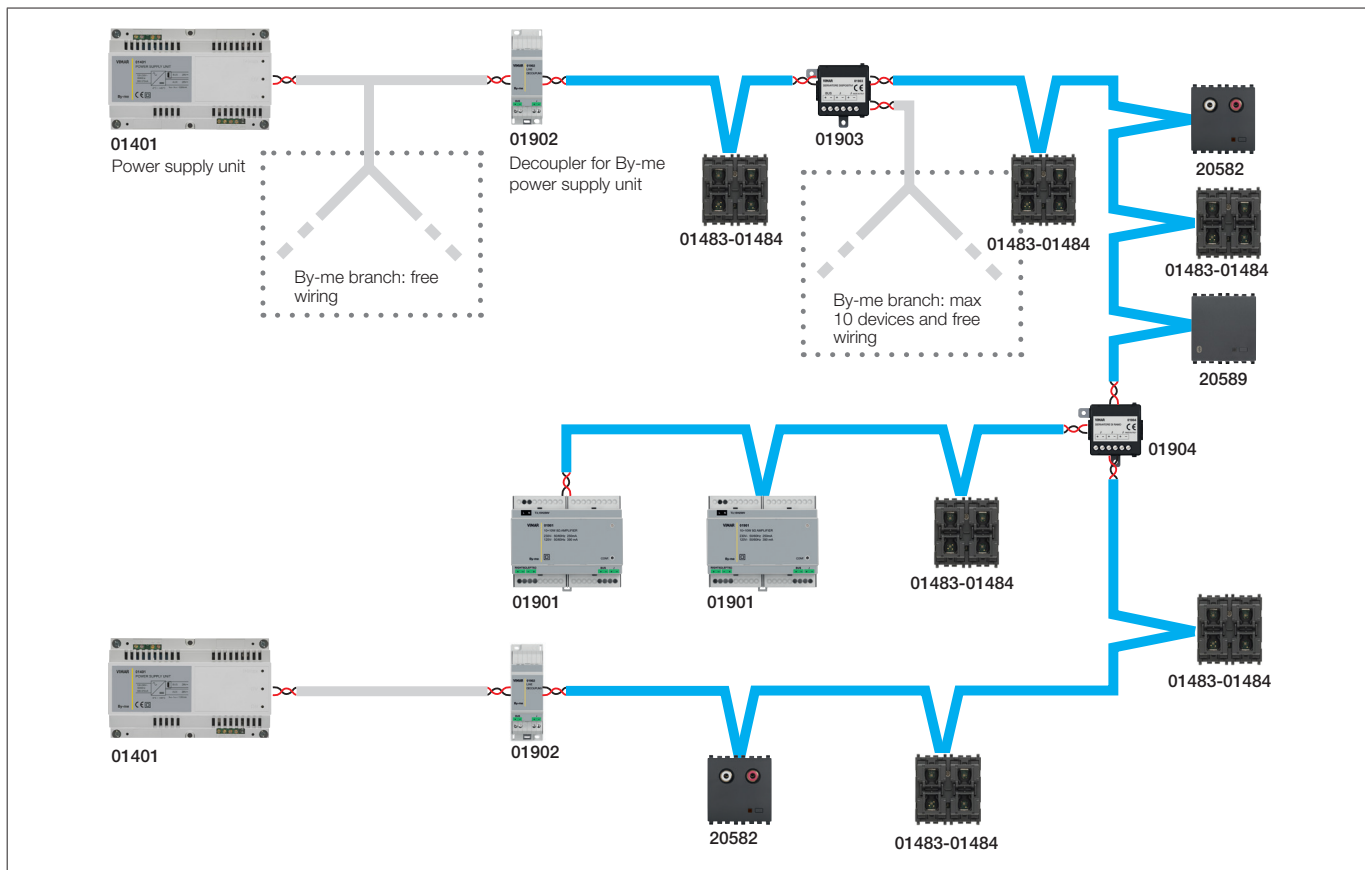

	By-me branch. Free wiring
	Sound system branch. By-me devices cannot be connected. In-out wiring (linear, not star); Max length 300 m. Max number of sound system devices: 64.
	The tap-off for the By-me control devices enables the creation of By-me branches that contain a max of 10 automation devices. Max no. of tap-offs 01903=64
	The tap-off for sound system 01904 enables the tapping off of Sound system branches.
	Decoupler for By-me power supply unit/Sound system. It must be inserted between the power supply unit and the audio line; none of the By-me devices between the decoupler and the power supply unit are "seen" by the sound system.

This explains how it is possible to make a completely integrated system with the By-me automation and sound system devices on the same branch.

Warning: By-me devices are not connected directly to the branch of the sound system (blue branch) but through special tap-offs or through the devices of the sound system (that have a special terminal).

7.3.2 Installation rules

The following installation rules are **compulsory** in the sections of the By-me bus dedicated to the sound system:

- Free wiring is not permitted in the sections dedicated to the sound system, but only the in-out linear type.** For shunting it is necessary to use the special branch tap-off for the sound system art. 01904.
- No more than 2 branch tap-offs can be wired per sound system (art.01904) between a transmitter and a receiver:** this is because the branch tap-off introduces strong signal attenuation.
- The section of BUS dedicated to the sound system is separated from the power supply unit (or from the line coupler if used) by the special "By-me power supply unit/sound system decoupler" art. 01902.**
- In the sections dedicated to the sound system (blue sections) only the sound system devices can be connected:** the By-me devices (where applicable) must be connected either through the specific branch tap-off for By-me devices (01903, max. 10 By-me devices) or through the dedicated terminal in each sound system device (branch with max. 3 By-me devices).

Sound system

5. Lastly, the devices at the ends of the sound system branches (at the start and at the end of the blue lines) must be terminated via the special jumpers present in each device. This applies to any device, whether it be a By-me power supply unit/sound system decoupler or a normal transmitter or receiver.

7.4 System restrictions

In order to ensure correct system operation and complete functionality, it is necessary to respect the installation restrictions.

7.4.1 Distances

The following table illustrates the system restrictions related to the distances between transmitters and receivers.

Maximum distance between a receiver and a transmitter with no intermediate tap-offs	300 m	See fig. A
Maximum distance between a receiver and a transmitter with 1 intermediate tap-off	200 m	See fig. B
Maximum distance between a receiver and a transmitter with 2 intermediate tap-offs	100 m	See fig. C

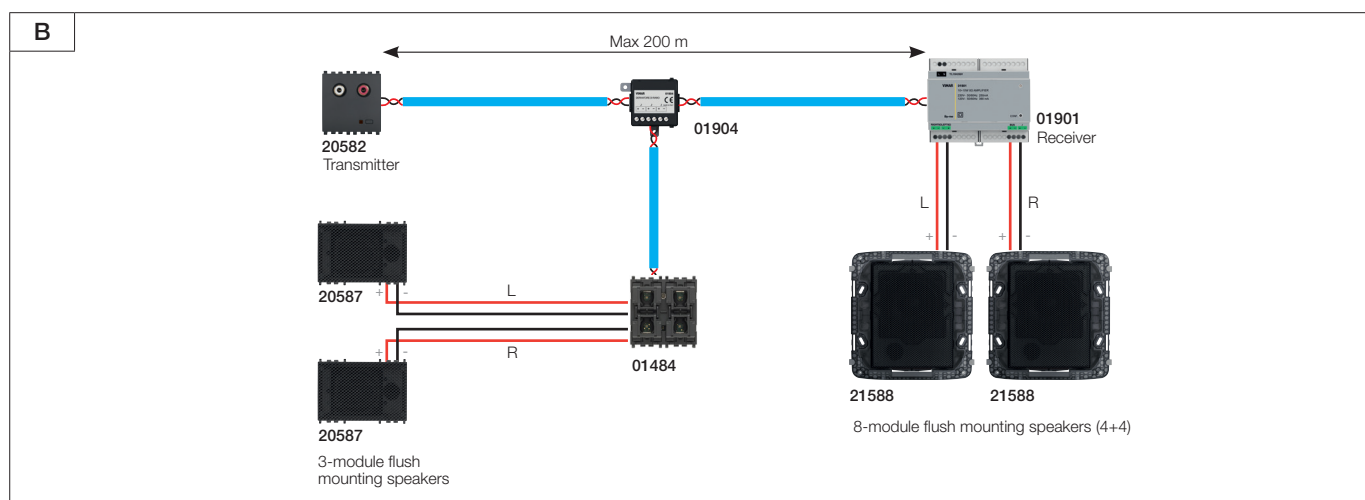
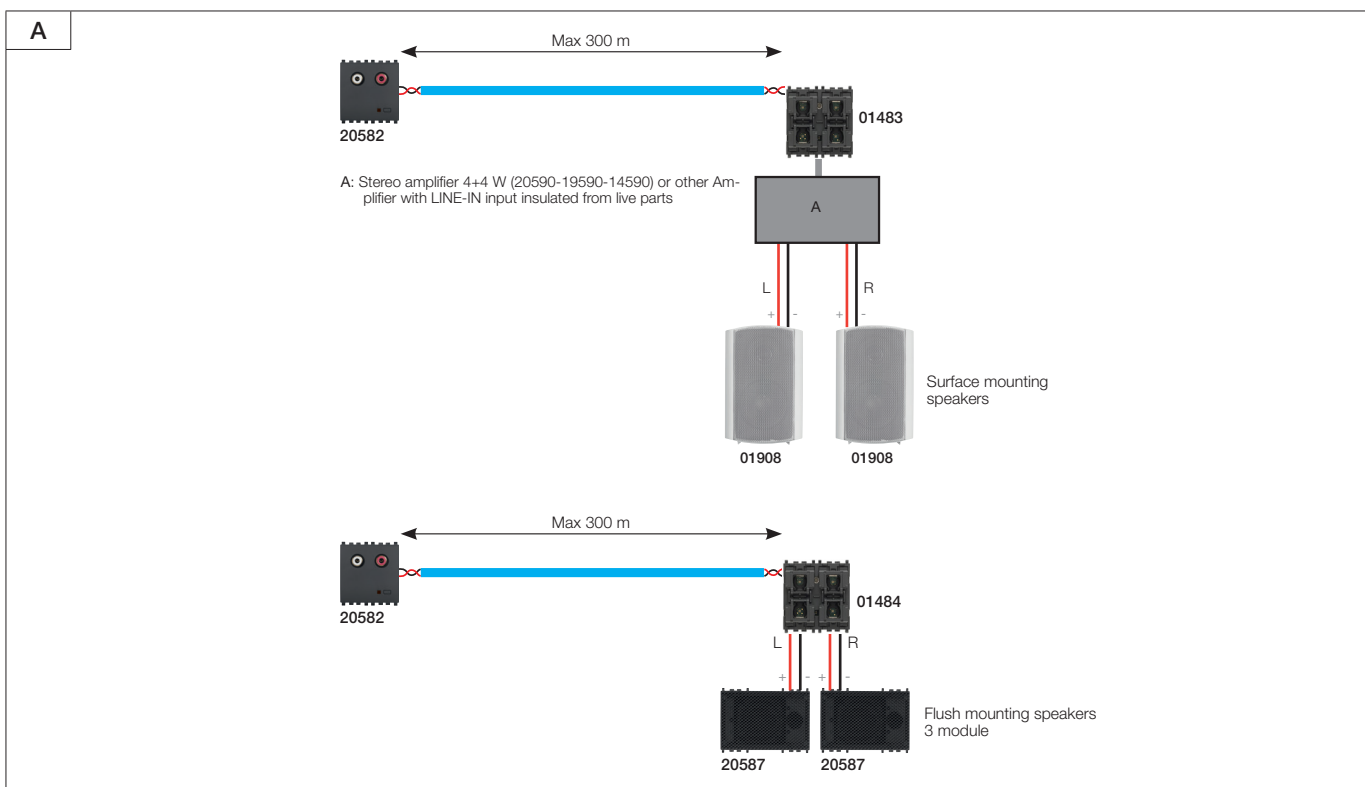

Sound system

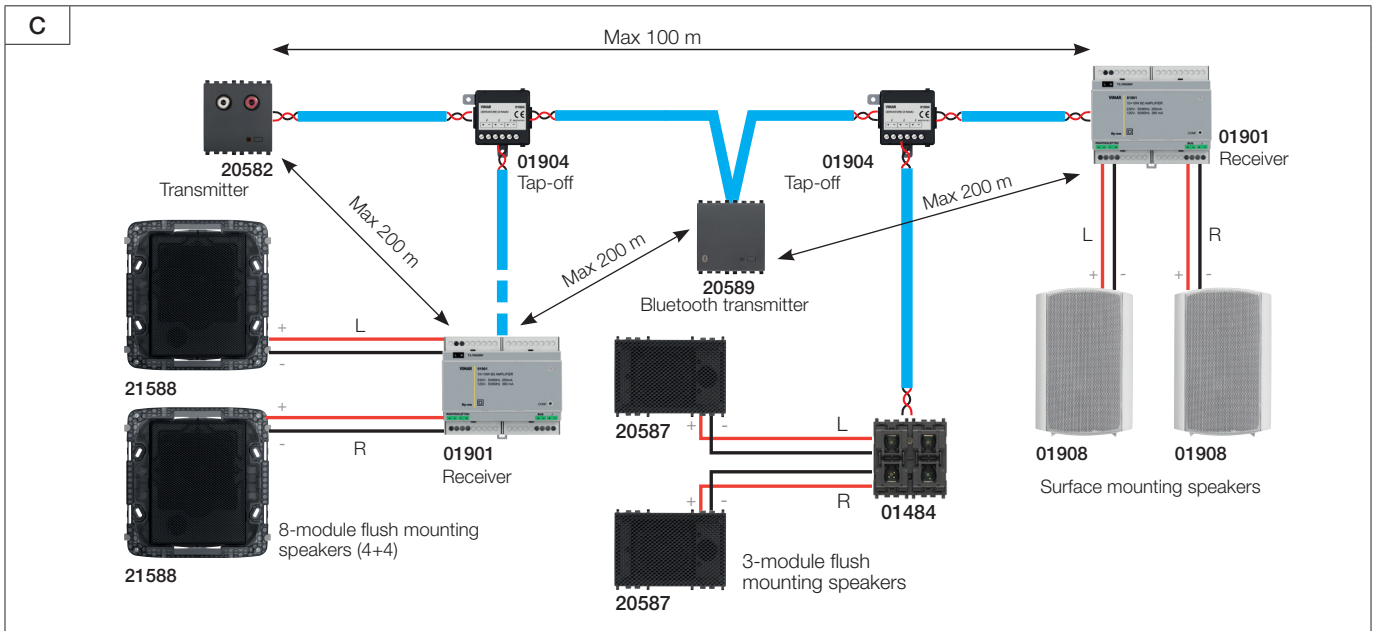

The following table illustrates the system restrictions related to the distances between receivers and speakers.

Distance between LINE OUT receiver (art. 01483) and power amplifier	10 m	See fig. D
Distance between 1+1W receiver (art. 30484-01484) and speakers	10 m	See fig. E
Distance between 10+10W receiver (art. 01901) and speakers	30 m	See fig. F

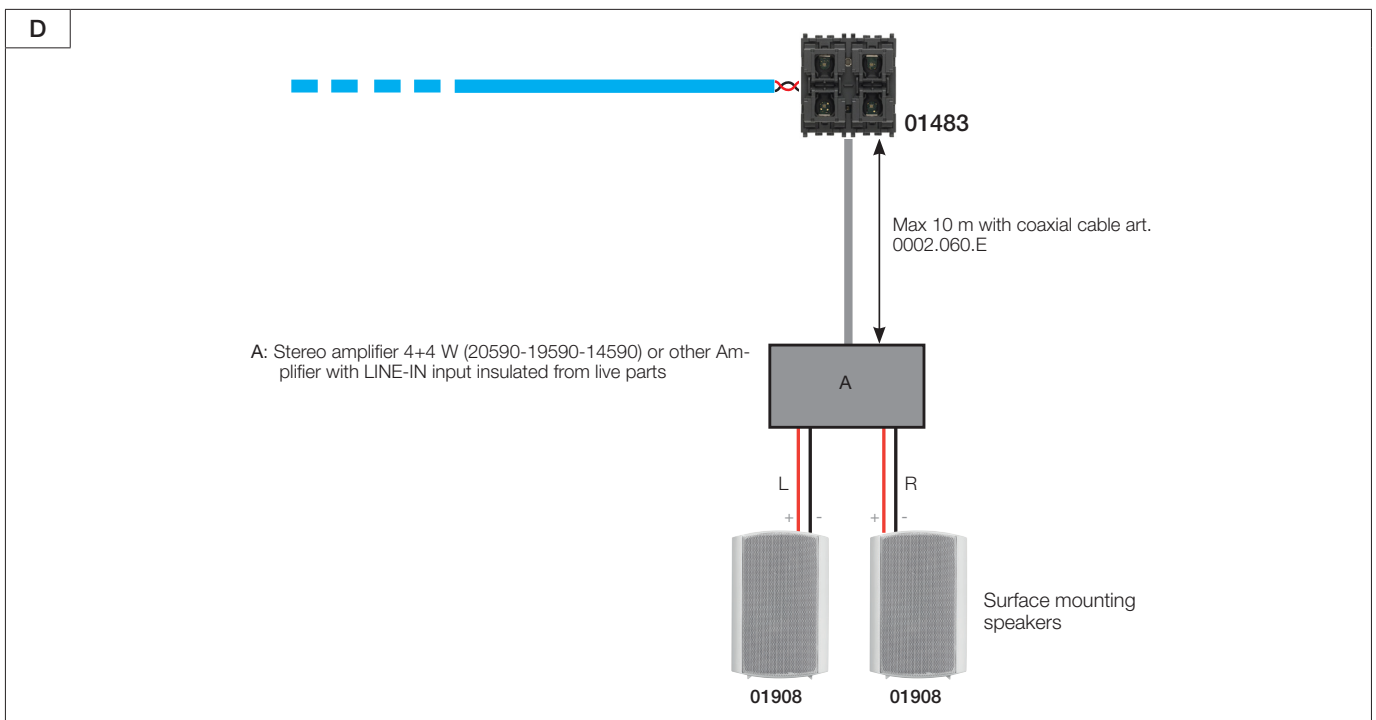

Sound system

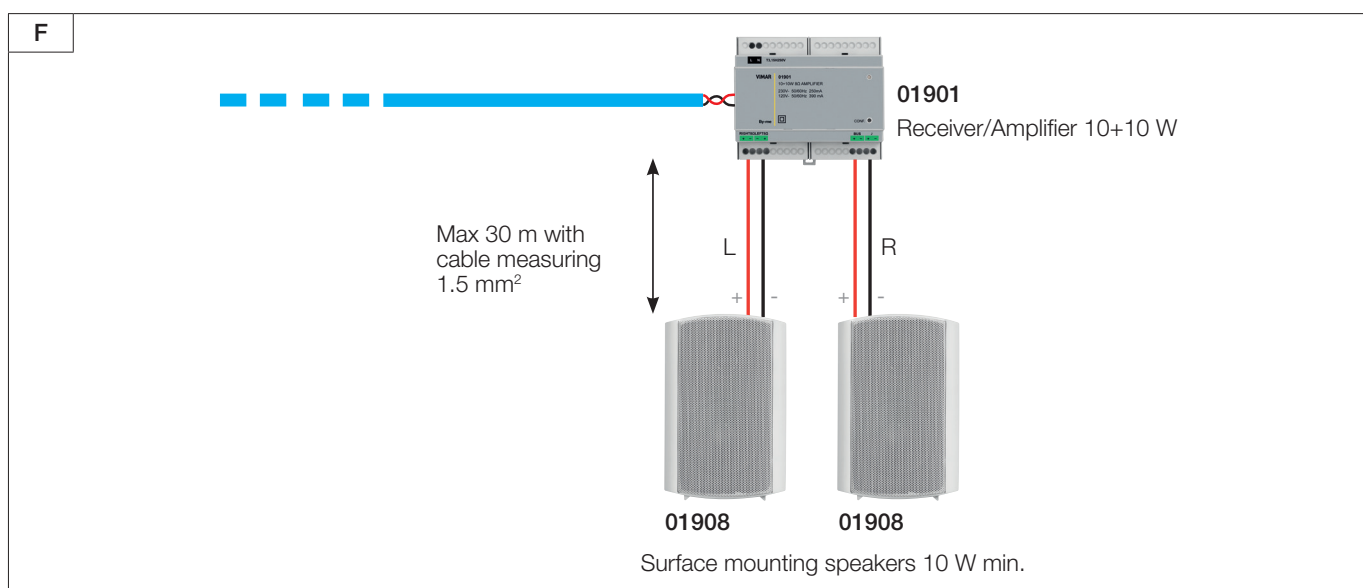
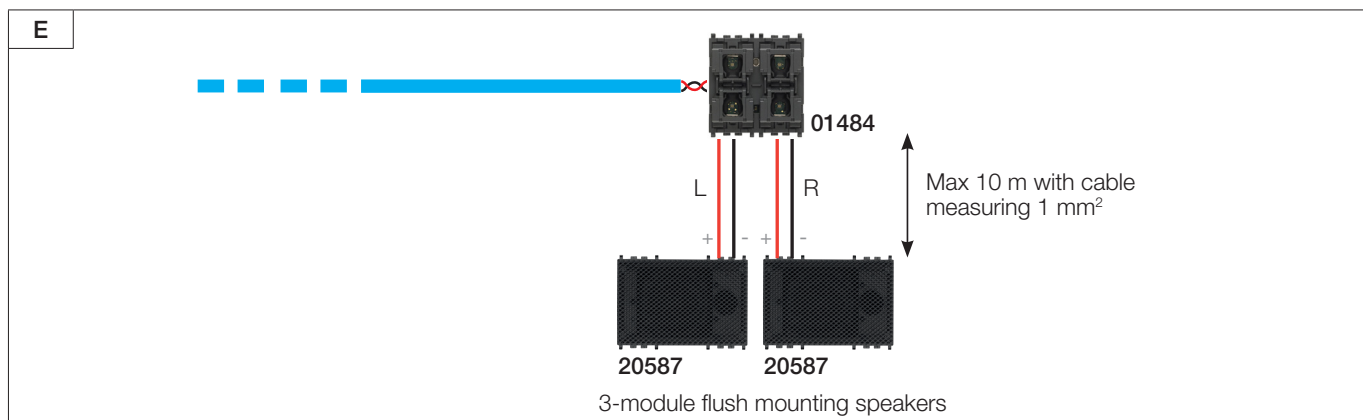

7.4.2 Absorption of devices and system dimensions

As the system is completely integrable with the By-me home automation system and uses the power supply units 01401, the limits of absorption to calculate for each line in the system are generally valid: max. 2 By-me power supply units 01401 and therefore max. 2 x 1280 mA. The sound system devices have different absorptions than the conventional By-me devices and therefore are to be considered when sizing the system.

The following table, useful for correctly sizing the system, gives the absorptions of the devices.

Device	Absorption	Notes
20582-19582-14582 TX flush mounting 2M 2-RCA	35 mA	Equivalent to 3 By-me devices
01900 TX /DIN with FM radio	35 mA	Equivalent to 3 By-me devices
20584-19584-14584 IR control for stereo	20 mA	Equivalent to 2 By-me devices
20585-19585-14585 TX docking station for iPod/iPhone	35 mA	Equivalent to 3 By-me devices
30495-20589-19589-14589 <i>Bluetooth technology</i> interface	35 mA	Equivalent to 3 By-me devices
01483 RX with LINE OUT output	35 mA	Equivalent to 3 By-me devices
30484-01484 RX with 1+1W flush mounting amplifier (if powered via BUS)	150 mA max	Equivalent to 15 By-me devices
30484-01484 RX with 1+1W flush mounting amplifier (if powered via power supply unit 20580-19580-14580)	10 mA	Equivalent to 2 By-me devices
01901 RX with 10+10W /DIN amplifier, 230V AC	20 mA	Equivalent to 2 By-me devices
20586-19586-14586 Call microphone module	35 mA	Equivalent to 3 By-me devices

CAUTION: The absorptions given in the table are only for the audio devices and do not take account of any other automation devices that may be connected to the By-me branch tap-off terminal.

Sound system

The high absorption of the 1+1 W receiver 30484-01484 (if powered directly by the Bus and not through the auxiliary power supply unit 20580-19580-14580) reduces its distance from the system power supply unit, especially if it is present at a number of points on the same branch.

With 1 receiver 30484-01484 powered by Bus	300 m
With 2 receivers 30484-01484 powered by Bus	150 m
With 3 receivers 30484-01484 powered by Bus	100 m
With 4 receivers 30484-01484 powered by Bus	75 m

These data refer to the case in which there is a number of 1+1 W receivers (art. 30484-01484) on the same branch and on the same side in relation to the By-me power supply unit 01401 (see figure below):

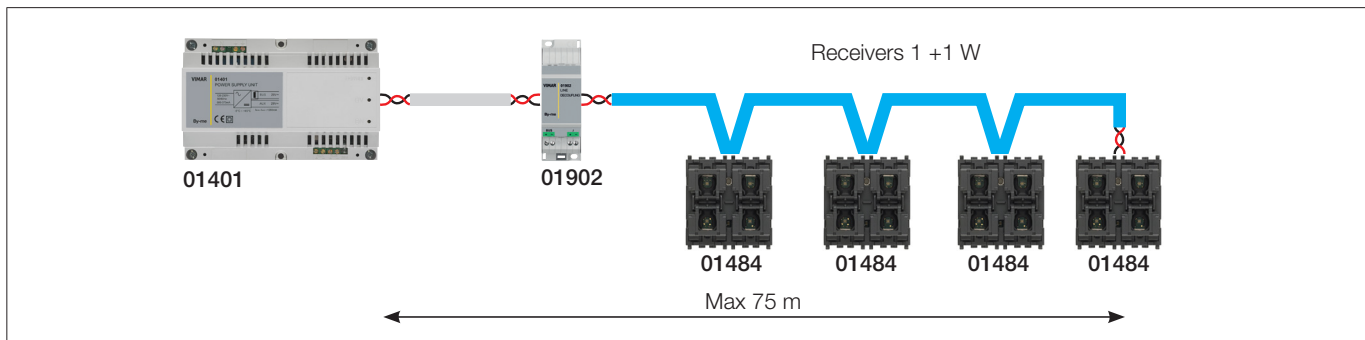

In the case in which the devices are always on opposite branches in relation to the By-me power supply unit, the distance must be calculated in relation to the power supply unit, counting the devices on the branch.

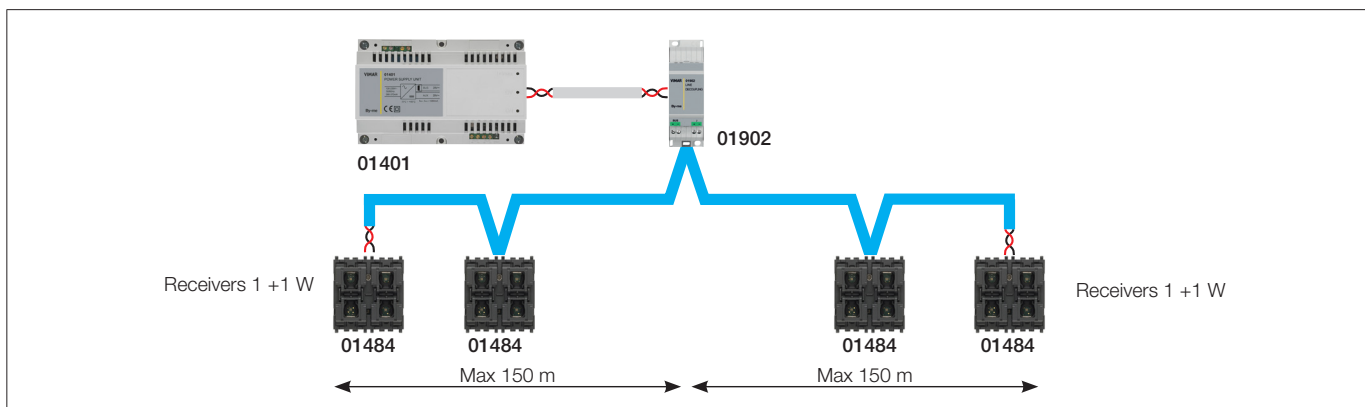

Therefore depending on the number of transmitters and receivers (and on their type) it is possible to calculate the absorption of the system and therefore the number of power supply units necessary, that in any case can be at most 2. If you want to install several 1+1W receivers (art. 30484-01484) it is advisable to use the auxiliary power supply units 20580-19580-14580.

7.4.3 Number of devices

As regards the number of devices that can be used on the branches of the sound system, the following restrictions apply:

Description	Number	Notes
Maximum No. of inputs (transmitters)	4	4 stereo channels
Maximum No. of "audio" devices (inputs, outputs, accessories)	64	Limit fixed by the input impedance of the "audio" nodes.
No. of receivers not powered by Bus	64 – no. of inputs – no. of accessories (tap-offs, decouplers, etc.).	Total: max 64 devices (transmitters, receivers, accessories). Each receiver can choose the audio channel from the 4 available ones
No. of receivers powered by BUS 30484-01484	A receiver powered via Bus consumes as much as 15 By-me devices: so max 4 devices per power supply unit	Indeed, the limits of the By-me power supply units 01401 apply: 1280 mA
No. of branch tap-offs for sound system (art.01902) between a transmitter and a receiver	2	Given the strong attenuation of the signal due to the tap-offs, it is necessary to make sure that the path between a transmitter and a receiver does not pass more than 2 of them.
Max. no. of microphone modules 20586-19586-14586	8	Possibility of making up to 8 different selective calls
No. of By-me "audio" tap-offs 01903	64 – no. of inputs – no. of other accessories	Each tap-off enables a By-me branch to be shunted beginning from the "audio" branch.
No. of By-me devices that can be connected to the By-me "audio" tap-off 01903	10	In each tap-off created by the decoupler I can connect max 10 By-me devices

Sound system

From what has been illustrated so far in relation to the topology, installation criteria and system restrictions, we can summarise that:

- Installation is linear (**in-out**) with the possibility of shunting via the special branch tap-offs for the sound system 01904.
- By-me devices must not be connected directly to the branch of the sound system but only through the tap-off 01903 or through the actual sound system devices (special terminal on each device in the sound system).
- A decoupling device is necessary between the power supply unit or in any case between the By-me bus and the audio transmission line: sound system/Bus line decoupler 01902
- Between the power supply unit and the sound system/By-me power supply unit decoupler the line maintains the By-me characteristics (free wiring, etc.).
- The tap-offs for the By-me branch 01903 enable shunting of a By-me line with max 10 devices and free wiring from the audio transmission line.
- The maximum distance between the transmitter and the receiver is:
 - 300 m if there are not tap-offs 01904
 - 200 m if there is a tap-off 01904
 - 100 m if there are 2 tap-offs 01904.
- The maximum number of sound system devices is 64 (including the tap-offs, decouplers and miscellaneous accessories).
- From each sound system device it is possible to shunt a mini By-me line with max. 3 devices.
- 2 power supply units can be used according to the absorption of the system; the second power supply unit can be connected at any point on the audio transmission line (not necessarily at the end as in the previous diagram), but the connection must always be made through the sound system/Bus line decoupler 01902.

7.5 Function

As mentioned above, the main function of the sound system is to transfer an audio signal from one point of the system to another; thanks to the system devices, moreover, it is possible to create a wide range of functions so as to satisfy every type of requirement:

- The transmitter module can be connected to any audio source (MP3, DVD player, Hi-Fi systems) through the RCA connectors.
- The **Bluetooth technology** interface is a transmitter for the sound system and is used to play audio content from a smartphone or tablet over the system.
- The FM tuner transmitter module transmits the radio signal.
- The call microphone module makes it possible to make voice communications paired with different services.
- The receiver modules are used to transmit the audio source with a different power output according to the context and the environment.
- The IR stereo control module is used to control the Hi-Fi system connected to an RCA transmitter module.

7.6 System components

7.6.1 Audio input with 2 RCA connectors, automatic adjustment of the input sensitivity, integrated line terminator.

This device is used, via the 2 RCA connectors, to acquire, digitise and transmit a generic analogue audio source (for instance a Hi-Fi system, CD player, portable MP3 player, etc.) over the By-me Bus. The By-me bus is galvanically decoupled from the audio inputs.

Technical characteristics

- Rated supply voltage: 29 V BUS
- Protection degree: IP30
- Galvanic decoupling of the audio inputs to the By-me bus.
- Possibility of manual control of the input sensitivity.
- Operating temperature: -5 ÷ +45 °C (indoor)
- Installation: flush or surface mounting (with surface mounting box 09975...)
- Consumption: 35 mA.
- Possibility of programming the relevant group
- Push button for configuration and manual setting of the input sensitivity.
- LED for configuration and manual setting of the input sensitivity.

Indicators

- LED: permanently lit during the configuration phase.
- LED permanently lit: the device is on.
- LED flashing quickly: adjustment phase to increase the input sensitivity.
- LED flashing slowly: adjustment phase to decrease the input sensitivity.
- LED flashing at high frequency: volume approaching the maximum threshold.

Operation

This device is used to transmit via bus the audio signal from an analogue sound source (all the audio sources marked with the "headphones" or "line out" symbol are suitable).

When the device is active the LED, where enabled, is permanently lit; the LED flashes at high frequency if the level of the input signal is near the maximum threshold. The optimal setting for the level is obtained when the LED is mainly permanently lit and flashes rarely at high frequency.

Note: An input signal volume that is too high can distort the audio signal.

Settings which can be configured directly from the device

To adjust the sensitivity of the audio inputs on the device manually, proceed as follows:

- Activate the device (status LED on) by switching on a listening zone.
- Press and hold down the configuration button to increase the sensitivity.
 - The LED flashes quickly; when the maximum value is reached or the push button is released, the LED returns to its normal operating status.
- Press and hold down the configuration button to decrease in the sensitivity.
 - The LED flashes slowly; when the minimum value is reached or the push button is released, the LED returns to its normal operating status.

Sound system

- Whenever the configuration push button is pressed, the sensitivity adjustment is reversed.

It is possible to run through the entire sensitivity adjustment scale, from the minimum to the maximum value and vice-versa in approximately 60 sec.

Just as in normal operation, during adjustment the high-frequency flashing of the LED indicates that the input audio intensity is approaching the maximum threshold. The optimum adjustment is reached when the high-frequency flashing of the LED is seen quite often. A permanently lit LED indicates that the input signal is too low; a high-frequency flashing LED indicates that the input signal is too high.

Settings that can be configured via the View Pro App

- LED management: Normal/Off; default value Normal

If the device is activated, the LED is lit.

- Mono/Stereo: default value Stereo.

Select the type of signal supplied on the RCA connectors; use the LEFT input for mono signals.

7.6.2 FM radio tuner with RDS, coaxial connector for external FM antenna, integrated line terminator, installation on DIN rail (60715 TH35), occupies 2 modules size 17.5 mm.

The FM tuner 01900 is able to send the digital audio signal and the RDS messages received by radio over the bus. The FM tuner receives the radio stations (with the related RDS information) in the 87.50 - 108.00 MHz band and in addition can save up to 8 different radio stations, which can later be called up with controls sent over the Bus by the By-me control devices or save in the scenarios.

N.B. If the radio function is included in the scenarios, the radio module must be added together with the groups of receivers so as to save the station to call up.

Technical characteristics

- Rated supply voltage: 29 V BUS

- Consumption: 35 mA

- Dissipated power: 1 W

- Installation: on DIN rail (60715 TH35), overall dimensions 2 modules

- Operating temperature: -5 ÷ +45 °C (indoor)

- Possibility of manual control of the input volume

- Push button for configuration and manual setting of the input volume

- Two-colour LED for configuration and indication of the operating ON/OFF status

- F-type female connector for external antenna

- 2 jumpers to insert the line termination

- Jumper to select the type of antenna (1= external antenna on connector F; 2= use the Bus cable as an antenna)

Indicators

- Red LED: permanently lit during the configuration phase;
- Green LED permanently lit: the device is on;
- green LED flashing quickly: adjustment phase to increase the volume of the input
- green LED flashing slowly: adjustment phase to decrease the volume of the input
- orange LED (permanently lit or flashing): input signal approaching the maximum threshold

Operation

The FM radio receiver with RDS 01900 is used as a digital audio signal transmitter within the sound system. It therefore receives the FM radio signal of the station tuned, digitises it and sends it to the various receiver devices of the system that requested it.

The main functions of the device are:

- Enabling or disabling the transmission of the audio content related to the FM radio (ON/OFF)
- Selecting a specific radio station
- Tuning onto the previous or next frequency in steps of 50 kHz
- Automatic frequency search with SNR above a given settable threshold
- Saving up to 8 different radio stations
- Possibility of calling up a specific memory/station (also from a scenario)
- Scanning the memories in succession in both increasing and decreasing directions
- Scenario management, calling up a specific radio station on activating the scenario
- Compatibility with the call mechanism: the device frees the audio transmission channel if the call takes place on the same channel it uses (the "call" is a service provided by the microphone module).
- Sending information related to the tuned frequency
- Sending information related to the strength of the radio signal received (RSSI)
- Sending information related to the On/Off status
- Sending information related to the value of the tuning memory (from 1 to 8).
- Sending, if available, RDS information received from the broadcasting radio station.

Settings which can be configured directly from the device

- To set the type of antenna, that is to say external on connector F or internal on the bus, you need to use the jumper situated next to the antenna connector, that is:
 1. **Antenna on connector F:** Connect together pins 3 with 5 and 4 with 6
 2. **Antenna on bus:** Connect together pins 3 with 1 and 4 with 2

To set the FM radio input volume manually, proceed as follows:

- Activate the device (status LED on) by switching on a listening zone.

- Press and hold down the configuration button to increase the sensitivity.

The LED flashes quickly; when the maximum value is reached or the push button is released, the LED returns to its normal operating status.

- Press and hold down the configuration button to decrease in the sensitivity.

The LED flashes slowly; when the minimum value is reached or the push button is released, the LED returns to its normal operating status.

- Whenever the configuration push button is pressed, the sensitivity adjustment is reversed.

Sound system

It is possible to run through the entire sensitivity adjustment scale, from the minimum to the maximum value and vice-versa in approximately 90 sec. Just as in normal operation, during adjustment the lighting of the orange LED indicates that the input audio intensity is approaching the maximum threshold. The optimal setting is reached when the lighting of the orange LED is quite frequent; the green LED permanently lit indicates that the input signal is too low while the orange LED permanently lit indicates that the input signal is too high.

Settings that can be configured via the View Pro App

- LED management: Normal/Off; default value Normal.
If the device is activated the green LED lights up to indicate information on the volume of the radio, otherwise it is off. If this parameter is set with the value 0, the green LED always remains off.
- Mono/Stereo: default value Stereo.
Selects the type of signal to transmit over the bus
- Percentage level of SNR: Default value 10%.
It is used during automatic frequency searching
- RDS On: default value On.
This value allows the device to send the RDS information over the bus (when available).
If set to Off, the device sends no information.
- RSSI On: default value On.
This value allows the device to send the RSSI (received signal strength indication) information over the bus.
If set to Off, the device sends no information.

7.6.3 Home automation devices with four push buttons, RGB LED visible in darkness with brightness control, to be completed with interchangeable half-button caps: 1 or 2 module Eikon, 2 module Arké or Plana.

01483: The device, connected to the sound system bus, is equipped with a LINE OUT output used to take the non-amplified audio signal from the selected channel and send it, where required, to an amplifier. The device is also equipped with four independent push buttons that can also be configured as rocker buttons equipped with RGB LED with configurable colour, for setting and control functions in By-me home automation systems (control of lighting, roller shutters, audio functions, etc.).

30484-01484: This device, equipped with 1 + 1 Wrms stereo amplifier, is used to play the audio data received on the Bus through the speakers connected to its outputs. The device is also equipped with four independent push buttons that can also be configured as rocker buttons equipped with RGB LED with configurable colour, for setting and control functions in By-me home automation systems (control of lighting, roller shutters, audio functions, etc.).

Common technical characteristics

- Rated supply voltage: 29 V BUS

Four independent push buttons that can also be configured as rocker buttons equipped with RGB LED with configurable colour, for setting and control functions in By-me home automation systems (control of lighting, roller shutters, audio functions, etc.)

- red LED and configuration push button
- Jumpers to insert the audio line-end termination
- Operating temperature: -5 ÷ +45 °C (indoor use)
- Protection degree: IP20
- Installation: flush or surface mounting (with surface mounting box 09975...)

Characteristics of art. 01483

- Terminals:
 - 2 for the sound system bus
 - 2 for a By-me bus output for connecting up to 3 By-me devices
 - 3 for connection to the external amplifier
- Absorption on the sound system bus: 35 mA
- LINE OUT output for connection of external amplifiers

Characteristics of art. 30484-01484

- Auxiliary power supply (optional, used to avoid current consumption from the audio bus): 32 V d.c. SELV
- Terminals:
 - 2 for the sound system bus
 - 2 for a By-me bus output for connecting up to 3 By-me devices
 - 2 for the auxiliary power supply at 32 V D.C. SELV
 - 4 for the connection to the 2 audio speakers (8Ω, 1+1 W rms)
- Absorption on the sound system bus:
 - 150 mA max. if powered via BUS
 - 10 mA if powered via 32 V auxiliary power supply unit
 Depending on the dimensions of the audio system it is possible to install the auxiliary power supply unit 20580-19580-14580 so as not to have to use another power supply unit 01400 or 01401.
- 8Ω speaker output, 1+1 W rms

Configuration

FUNCTIONAL UNITS

- For the push button logic function, one of the following functional units can be selected:
 - push button
 - dimmer control
 - roller shutter control
 - timed only control*
 - timed* and ON/OFF control
 - scenario control

Sound system

- send value
 - sleep (control for sound system)
 - audio monitoring (control for sound system)
 - For the rocker button logic function, one of the following functional units can be selected:
 - rocker button
 - dimmer control
 - roller shutter control
 - timed only control*
 - timed* and ON/OFF control
 - Volume On/Off (volume control for sound system)
 - sleep (control for sound system)
 - ch+/track+ (control for sound system)
 - For the audio output only the audio output functional unit is available
- * Configuration of the timed control is only possible if there is already at least one actuator in the application with a timed function.
- Parameters of the audio zone to which the receiver belongs (audio output functional unit)
 - priority
 - sleep time (timed switch-off);
 - max volume of the zone
 - max power-on volume
 - call volume
 - max mute volume
 - behaviour of the zone switched off in the event of a general call
 - behaviour of the zone switched off in the event of a selective call made to it
 - active channels

7.6.4 Stereo amplifier with 2 outputs for 8 ohm 10 + 10 W speakers, power supply 110-230 V 50-60 Hz, integrated line terminator, installation on DIN rail (60715 TH35), occupies 6 modules size 17.5 mm.

The stereo amplifier 01901 is used to play the audio signal received on the Bus through the speakers connected to its outputs.

Technical characteristics

- Rated supply voltage: 110-230V~, 50-60Hz
- Terminals:
 - 2 for the sound system bus
 - 2 for a bus output to which max. 3 By-me devices can be connected
 - 2 for power supply at 110-230V~
 - 4 for the connection to the 2 audio speakers
- Operating temperature: -5 ÷ +45 °C (indoor)
- Consumption on the bus: 20 mA
- Possibility of programming the receiver zone
- Configuration push button
- Installation: on DIN rail (60715 TH35), overall dimensions 6 modules
- Red/green two-colour LED:
 - 1) on red during configuration
 - 2) flashing red following overheating of the amplifier
 - 3) green to signal the status of the receiver, depending on the LED management parameter (which can be set at the time of configuration).

Parameters

- LED management
- Power reduction

Besides these parameters there are the typical ones of the relevant zone:

- Priority;
- Sleep time (timed switch-off);
- Max volume of the zone
- max power-on volume
- Call volume
- Max mute volume
- Behaviour of the zone switched off in the event of a general call
- Behaviour of the zone switched off in the event of a selective call
- Active channels

7.6.5 Bluetooth® technology interface for home automation.

The device is a *Bluetooth technology* interface that acts as a transmitter in the sound system to input the audio from a smartphone or tablet (Android and iOS) on a BUS channel.

The device not only sends an audio signal to the receiver devices, but also remotely controls smartphones or tablets (play/pause, skip+/- track functions), by sending the appropriate controls over the bus.

Sound system

Technical characteristics

- Rated supply voltage: 29 V BUS
- Consumption: 35 mA
- Terminals:
 - 2 for the sound system bus
 - 2 for a By-me bus output for connecting up to 3 By-me devices
- RGB LED indicating the status of the internal radio module and the device configuration phase
- Configuration push button
- Jumpers to insert the audio line termination
- Operating temperature: -5 ÷ +45 °C (indoor use)
- Protection degree: IP20
- Installation: flush or surface mounting (with surface mounting box 09975...)
- Supports Bluetooth® technology Version 4.2 and is compatible with Bluetooth® A2DP 1.3 and AVRCP 1.6 profiles.

Operation

- Possibility of storing up to 8 mobile devices (smartphone, tablet, etc.).
N.B.: Any ninth device stored overwrites the first one stored, and so on.
- Pairing: the internal radio module searches for a mobile device to store.
- The **Bluetooth technology** interface allows you to play the audio content on mobile devices over the sound system and to control the following functions:
 1. Play/pause: starts/stops playback of the selected song
 2. Track+/-: used to scroll through a playlist, moving to the next or previous track.
- Used to send information about the track, album and artist being played to the bus.
- The volume can be controlled directly from the smartphone or tablet.

Configuration push button

- If the configurator is waiting to configure a device, a short press will put the device in configuration.
- If the configurator is waiting to delete a device, a long press (10 s) will reset the device.
- In normal operation, press the internal radio module briefly to switch it on or off.
- In normal operation, a long press (10 s) activates the Pairing function. If no remote device is found, this procedure is terminated after a timeout of 90 s.

Indicators

- LED permanently lit with the colour set during configuration: internal radio module on but interface off..
- LED flashing with the colour set during configuration: interface on and transmitting an audio signal over the bus.
- LED flashing red: input signal exceeds preset threshold (lower the volume on the smartphone/tablet).
- LED flashing blue: Pairing function activated.

Settings that can be configured via the View Pro App

- LED on brightness: allows you to select the brightness level of the LED when the module or device are on (high brightness, medium brightness, low brightness, off)
- LED off brightness: allows you to select the brightness level of the LED when the module and device are off (high brightness, medium brightness, low brightness, off)
- LED colour: allows you to select the colour of the LED from a default list or to set the desired RGB coordinate directly.
- Mono/Stereo: default value Stereo.
- Signal gain: allows you to set, in the range 0 to 100, the gain relating to the audio signal received via **Bluetooth technology** and sent over the bus.

7.6.6 Microphone for selective or general call, voice activation function to control children (Baby Control) and for audio monitoring - 2 modules

The microphone 20586-19586-14586 is a transmitter device capable of picking up the signal detected by the built-in audio source and transmitting it, via a call procedure, to specific zones in the system (selective calls) or to all the zones (general call). The zones involved in the call switch over the receivers onto the carrier channel signalled by the call, they play back the audio content picked up by the microphone and finally, after the end of call message, they recommence the operation immediately prior to the call.

Technical characteristics

- Rated supply voltage: 29 V BUS
- Terminals:
 - 2 for the sound system bus
 - 2 for a By-me bus output for connecting up to 3 By-me devices
- Operating temperature: -5: +45°C (indoor).
- Installation: flush or surface mounting (with surface mounting box 09975...)
- Consumption: 35 mA
- Configuration push button
- Central red configuration LED
- Maximum number of microphones that can be installed in the system: 8
- Front right-hand rocker button that can be configured with the following functions:
 - If configured in an audio output group:
 - 1) On/Off audio zone plus volume adjustment
 - 2) Change track and audio source
 - 3) Sleep (timed switch-off of an audio zone)

Sound system

- If configured in a Call group
 - 1) Audio Monitoring control, if configured with a remote call module
 - 2) General and Selective Call control if configured with the local call module (primary function of the button paired with the interchangeable buttons provided in the package).
- If configured in an automation group:
 - 1) ON/OFF 1-way switch
 - 2) Dimmer control
 - 3) Roller shutter control
 - 4) Scenario control
- Front lower left-hand push button paired with the module's Baby-Control function
- Two green LEDs located in the middle of the 2 rocker buttons with functions that can be configured
- Jumpers to insert the audio line termination

Operation

In the standard configuration of the front buttons, the following functions can be used:

- **"Push To Talk" general call.**

Instantaneous call on pressing the front upper right-hand button and directed to all the system's zones; they will transmit the voice signal picked up by the device's microphone as long as the button is kept pressed.

The call ends when the button is released.

By using the View Pro App, it will be possible to set the behaviour of every zone following a General call (for example the behaviour of the zone if switched off, the call playback volume, etc.).

- **"Push To Talk" selective call.**

Instantaneous call on pressing the front lower right-hand button and directed to a subset of system zones; by using the App, it is possible to set the zones receiving the selective call by accessing the device parameters.

Only the audio zones corresponding to the selected ones, indicated in the selective call start message, will switch onto the call channel and will transmit the user message as long as the button is kept pressed.

The call ends when the button is released.

By using the View Pro App, it will be possible to set the behaviour of every zone following a Selective call (for example the behaviour of the zone if switched off, the call playback volume, etc.).

- **"Baby Control" service.**

To turn this function on/off, simply press and then release the front lower left-hand button that will be followed by the LED signal.

Once the function has been activated, if the volume of the voice signal picked up by the microphone exceeds the set threshold, a selective call is sent to a set of system zones; the threshold value can be set with the App.

The call remains active until a few seconds after the audio has returned under the threshold value to then reactivate automatically when later on the threshold gets exceeded.

By using the View Pro App, it is possible to set the zones intended for the Baby Control service. The typical application of this function is monitoring children while they sleep.

- **Audio Monitoring**

This function enables remote activation of the call microphone with a By-me push button provided that both devices are configured in the same application.

It is then possible to monitor the audio of a specific environment; this audio monitoring function is accomplished with the By-me push button that activates a selective call, initiated by the microphone module, intended for a set of system zones.

Using the App, it is possible to set the zones for the Audio Monitoring.

IMPORTANT:

- As an alternative to the standard configuration, that is forgoing "Push To Talk Calls" and maintaining the "Baby Control" and "Audio Monitoring" function, the two right-hand buttons of the microphone 20586-19586-14586 can be used as By-Me controls (lights, roller shutters, audio).
- If there are a number of microphones 20586-19586-14586 in a system, only one active Call is permissible (general or selective) in the system irrespective of audio channel availability.
- During call playback, the central LED of the rocker buttons of the microphones 20586-19586-14586 signal there is a call by flashing (obviously this happens if the rocker button is configured for the call functions).

7.6.7 Interface for transmission of By-me controls to IR receiver, complete with 3 m cable.

The IR interface is used to control audio sources (stereo combo, CD/DVD players, etc.) learning and emulating the controls of the original remote control of the equipment to control. Paired with an RCA transmitter (art. 20582-19582-14582) it therefore makes it possible to have sound sources controlled directly by the By-me system.

Technical characteristics

- Rated supply voltage: 29 V BUS
- Terminals: 2 for the By-me bus
- 2.5 mm jack connector
- Operating temperature: -5 ÷ +45 °C (indoor)
- Installation: 1-module flush mounting
- Consumption: 20 mA
- Possibility of programming the relevant group (it must be paired with an RCA input module)
- Possibility of registering and repeating max. 12 buttons of an infrared remote control
- Configuration push button
- Two-colour LED for configuring and indicating infrared transmission and reception
- 3 m cable with 2.5mm jack and IR transmitter (supplied)

Sound system

Indicators

- Red LED: permanently lit during the configuration phase.
- Green LED permanently lit: the device is on.
- Flashing green LED: reception of a By-me control that requires sending IR controls.
- Flashing red LED: error in managing/registering an IR control.
- Flashing orange LED: reception of the By-me control for starting the learning phase and waiting for the configuration push button to be pressed.
- Orange LED permanently lit: starting registration phase and waiting for an IR remote control button to send an infrared code.

Operation

The device is capable of saving the button of an infrared remote control and of replicating its operation following a By-me control. When the interface is active the LED, if enabled, is permanently lit green; it flashes briefly each time a By-me control is received that involves sending IR controls.

It is possible to acquire up to 12 actions (action = repetition of an infrared remote control button) that are named as follows:

- Action 1
- Action 2
- Action 3
- Action 4
- Action 5
- Action 6
- Action 7
- Action 8
- Action 9
- Action 10
- Action 11
- Action 12

Operation is ensured when, starting with the actions, the following controls thus named are coded:

Control	Meaning
On	Powering up the device, selecting the source and starting playing
Power-down	The device goes onto stand-by
Skip next	Next track/memory
Skip previous	Select previous track/memory
Play	Start playing
Stop	Stop playing
Pause	Pause playing
Resume	Exit pause and start playing again
Sel. Source 1	Select source 1
Sel. Source 2	Select source 2
Sel. Source 3	Select source 3

Configuration

The IR interface 20584-19584-14584 is configured in two phases:

1. Registration button of a remote control (action)
2. Pair actions with the actual control.

Creation of an action and registering the key of a remote control

Follow the instructions displayed by the View Pro App

Press the configuration button of the interface 20584-19584-14584; the orange LED will be permanently lit.

Move the remote control near to the IR interface (to a distance of about 10 cm) and continuously press the button you want to register.

Save the setting made.

If acquisition is successful, the interface LED will flash green; the action will then be displayed in the list of configured actions (A1, A2, etc.).

If the acquisition is not successful carry out the following check:

- position the remote control towards the window of the IR interface at a distance of about 10 cm;
- if the orange LED does not become red or green (flashing) check the operation of the remote control button on the audio device;
- check that the infrared frequency of the audio device is between 30kHz and 60kHz;
- if the LED is flashing red try the entire sequence again.

Sound system

As regards the remote control, you should save the buttons that are generally used for the ON, OFF, SKIP, PLAY, STOP, PAUSE and source selection (in the case of a multi-source device) operations and in the table below note down the reference between the name of the memory used and the corresponding remote control button.

Action	Remote control button
Action 1	
Action 2	
Action 3	
Action 4	
Action 5	
Action 6	
Action 7	
Action 8	
Action 9	
Action 10	
Action 11	
Action 12	

The following page gives an example of configuring the remote control buttons and filling in the above table.

Pair actions with the actual control.

Use the related menu of the View Pro App to create the controls pairing up to 4 already registered actions.

Select the control to pair (**Power-on, Power-down, etc.**); 4 selection fields are then displayed (**Action 1, Action 2, Action 3 and Action 4**), each one of which represents an action paired with the control.

The 4 fields will show dashes if there is no paired action.

It is now possible in each field to choose any of the registered actions; the fields are indexed from 1 to 4 that is the order in which the actions will be performed by the control.

Lastly touch **Set** that causes the data to be transferred to the IR device.

Other parameters

On the screen for the parameters of the IR interface there are also:

- **LED management:** (Default value 1=enabled). If the device is activated, the green LED is lit.
- **Inter-time [sec]:** (Default value 1 s). Time in seconds that must pass between one repetition of an IR button and another one, that is between consecutive actions mapped within the same control.

If the consecutive actions refer to the same button, the inter-time is not applied.

Example.

Action	Remote control button
Action 1	POWER
Action 2	SKIP+
Action 3	SKIP-
Action 4	PLAY
Action 5	STOP
Action 6	PAUSE
Action 7	CD
Action 8	RADIO
Action 9	AUX
Action 10	-
Action 11	-
Action 12	-

Sound system

Control	Action 1	Action 2	Action 3	Action 4
On	Action 1	Action 7	Action 4	None
Power-down	Action 5	Action 1	None	None
Skip next	Action 2	None	None	None
Skip previous	Action 3	None	None	None
Play	Action 4	None	None	None
Stop	Action 5	None	None	None
Pause	Action 6	None	None	None
Resume	Action 4	None	None	None
Sel. Source 1	Action 7	None	None	None
Sel. Source 2	Action 8	None	None	None
Sel. Source 3	Action 9	None	None	None

In the example above note that the On control is coded as the playback sequence of Actions 1, 7 and 4 that correspond to pressing the POWER, CD and PLAY buttons of the original remote control in sequence. The operation of switching on is then paired with the actions of the three buttons indicated alternated by the inter-time parameter that causes switching on the device, selecting the CD source and starting playback as required for the Power On control.

Summary of signals of IR interface 20584-19584-14584

Problem	Cause	Solution
The green status LED does not light up or does not flash.		Check that the LED parameter is enabled.
The green status LED does not light up or does not flash yet.	Before being able to receive other types of controls, the IR interface must be on	Send the on control (if enabled, the green LED must be permanently lit to receive other controls)
The audio system is not controlled.		Check that, on sending the By-me control, the green LED flashes. Check the IR cable; it must be positioned about 1 cm from the receiver. If necessary, before positioning the transmitter with the adhesive, test the send sequence varying the position. Check you have registered the button for the desired control with the corresponding By-me control.
A control does not produce the desired function.	While having been correctly coded, it might not be sufficient to send the control by pressing the paired IR button just once.	Map the repetition of the same Button on the same Control in consecutive positions. For example, the Play control could be coded as Action 1 = Button 4, Action 2 = Button 4, Action 3 = None, Action 4 = None (this is presuming you have saved the Play button of the remote control on Button 4). This action causes repeated pressing of the play button paired with the Play control.

7.6.8 Decoupler for Bus line/sound system for By-me power supply unit, integrated line terminator, installation on DIN rail (60715 TH35), occupies 2 modules size 17.5 mm.

The line decoupler 01902 is the device that splits the By-me Plus system into:

- automation part (free wiring, BUS cable art. 01840.E);
- sound system part (in-out linear wiring, BUS cable art. 01840.B).

The sound system is therefore delimited by this device that, depending on the case, can be directly connected at the output to the power supply unit 01401 or to the line coupler 01845.1 or directly to the Bus of the automation part.

Technical characteristics

- Rated supply voltage: 29 V BUS
- Operating temperature: -5 ÷ +45 °C (indoor)
- Installation: on DIN rail (60715 TH35), overall dimensions 2 modules

7.6.9 Tap-off for By-me control devices, flush mounting (retrofit).

The tap-off 01903 is used for shunting from the sound system line (in-out linear wiring, Bus cable art.01840.E.B) to make an automation branch (free wiring, Bus cable art.01840.E) to which up to 10 By-me devices can be connected.

7.6.10 Branch tap-off for sound system devices, flush mounting (retrofit)

The tap-off 01904 is used for shunting two new audio branches from a sound system line, making it possible to create a star connection. This solution is useful in all those cases where the linear wiring is difficult or not feasible.

Sound system

7.7 Device parameters

Device parameters can be modified in order to customise and adapt the characteristics of the system to different installation requirements. The modifiable parameters for each functional unit depend on the characteristics of the unit and vary by type depending on the device considered (see the instructions sheets provided with each article).

■ Functional unit – audio output /DIN

- LED management: Off, Normal, Reversed, Always On
- Output power reduction = Off, On

This parameter must be set On when the 3M, 3W 8Ω flush-mounting passive acoustic speaker is connected.

■ Functional unit – RCA Audio Input

- LED management: Off, Normal
- Type of Audio: Mono, Stereo

■ Functional Unit - FM tuner

- LED management: Off, Normal
- Type of Audio: Mono, Stereo
- Search threshold: 0%, 100%

This is the threshold beyond which a station is considered as valid during an automatic search

- RDS text: Off, On
- RSSI: Off, On

■ Functional unit – Microphone/Call

- LED management: Off, Normal
- Baby Control threshold = from 0 to 15 (0 = maximum activation sensitivity)

This is the threshold of the audio signal captured by the microphone, beyond which the "Baby Control" function is activated

- Call zones: On, Off, zone by zone

This is used to select the audio zones to activate during a "Push to Talk" selective call

- Baby Control zones: On, Off, zone by zone

This is used to select the audio zones to activate during a selective call corresponding to the "Baby Control" service

- Audio Monitoring Zones: On, Off, zone by zone

This is used to select the audio zones to activate during a selective call corresponding to the "Audio Monitoring" service

■ Functional unit – Rocker button for Audio control

- LED management: Off, Normal, Reversed, Always On, Ctrl LED Normal, Ctrl LED Reversed, Ctrl LED On
- Operation: Default = On-Off/Volume

This functional block refers to a rocker button control to perform the functions of zone switching on/off and adjusting the volume.

The Operation parameter can be changed later on according to the type of control: Volume On-Off, Skip Channel/Track, Sleep Audio.

The LED Management parameter can also have values for the double button with the central LED (except for the rocker button of the call microphone 20586-19586-14586).

Note: when "Skip Channel/Track" operation is selected LED Management is automatically disabled: the value of the "LED Management" parameter becomes "Off".

Skip Channel/Track operation	RH By-me automation/audio rocker button	Central By-me automation rocker button	LH By-me automation/audio rocker button
LED management parameter	OFF Always ON	OFF Always ON CENTR Always ON	OFF Always ON CENTR Always ON

■ Functional unit – Rocker button for Audio List.

- LED management: Off, Normal, Reversed, Always On, Ctrl LED Normal, Ctrl LED Reversed, Ctrl LED On
- Operation: Default = On Off

This functional block refers to a rocker button control configured automatically by the App to perform the function of switching audio monitoring on/off; the Operation parameter must always remain set to Audio Monitoring.

The LED Management parameter can also have values for the double button with the central LED (except for the rocker button of the call microphone 20586-19586-14586).

■ Functional unit – IR stereo control

- LED management

■ Functional unit - Bluetooth module

- RGB LED colour: red, green, blue, amber, white, cyan, magenta, custom
- LED ON brightness: OFF, low, medium, high
- LED OFF brightness: OFF, low, medium, high
- Type of Audio: Mono, Stereo
- Signal gain: 0%, 100% default=65%

Sound system

7.8 Types of system

This chapter, by way of example, illustrates some types of installation that can be made with the sound system.

7.8.1 Audio zones with receiver modules and By-me controls

This example illustrates a typical installation in which one or more zones can play the audio source coming from the transmitter modules.

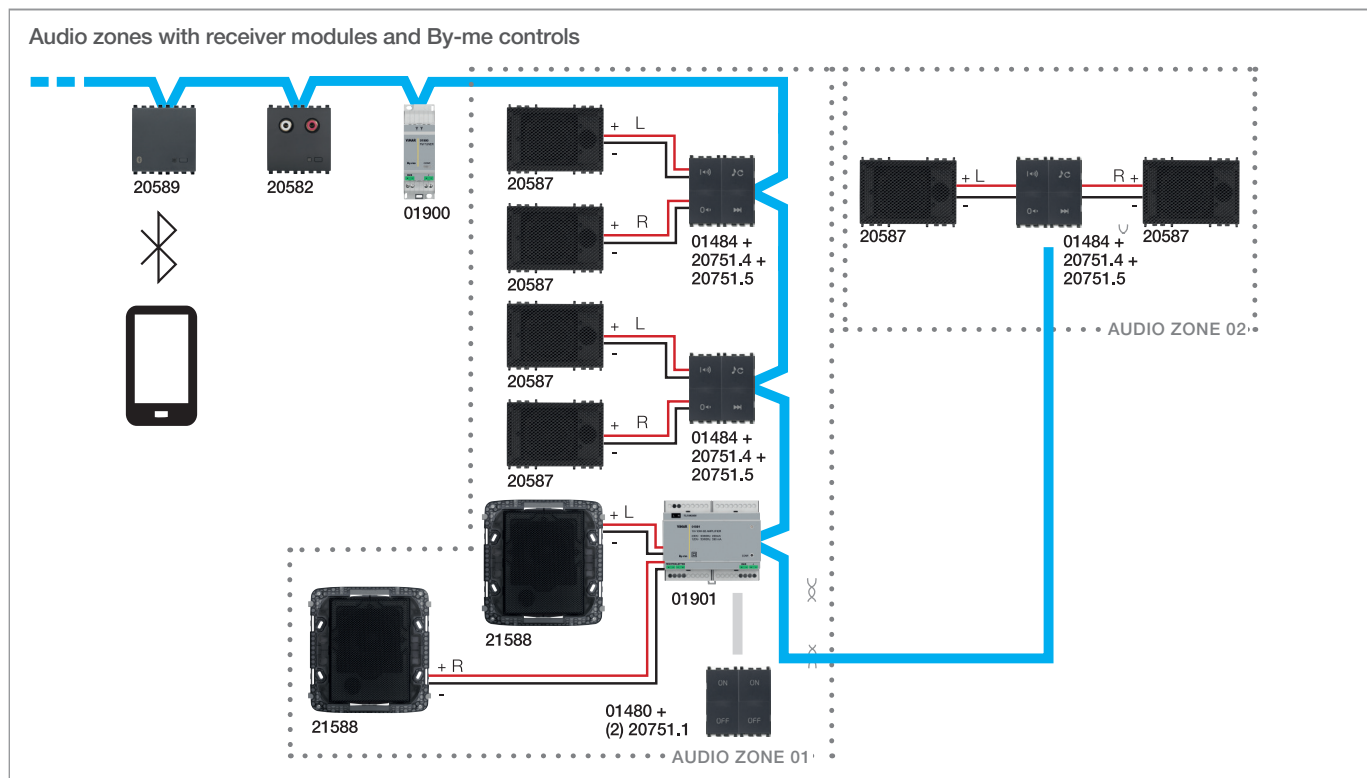

Devices configured: 2x audio inputs 20585 and 20582, 1x FM tuner 01900 and 1x *Bluetooth technology* interface 30495-20589 (transmitter modules), 4x audio amplifiers 30484-01484 (receiver modules) with the related control buttons 20751.4 and 20751.5.

Applications created: four for the transmitter modules and two for the receiver modules, with control buttons.

Zones created: two audio zones paired with the corresponding groups of receivers.

Operation: the two zones work independently to play the audio channels.

The control buttons perform their actions on the entire zone in which they are configured.

Sound system

7.8.2 Audio zones with voice call function

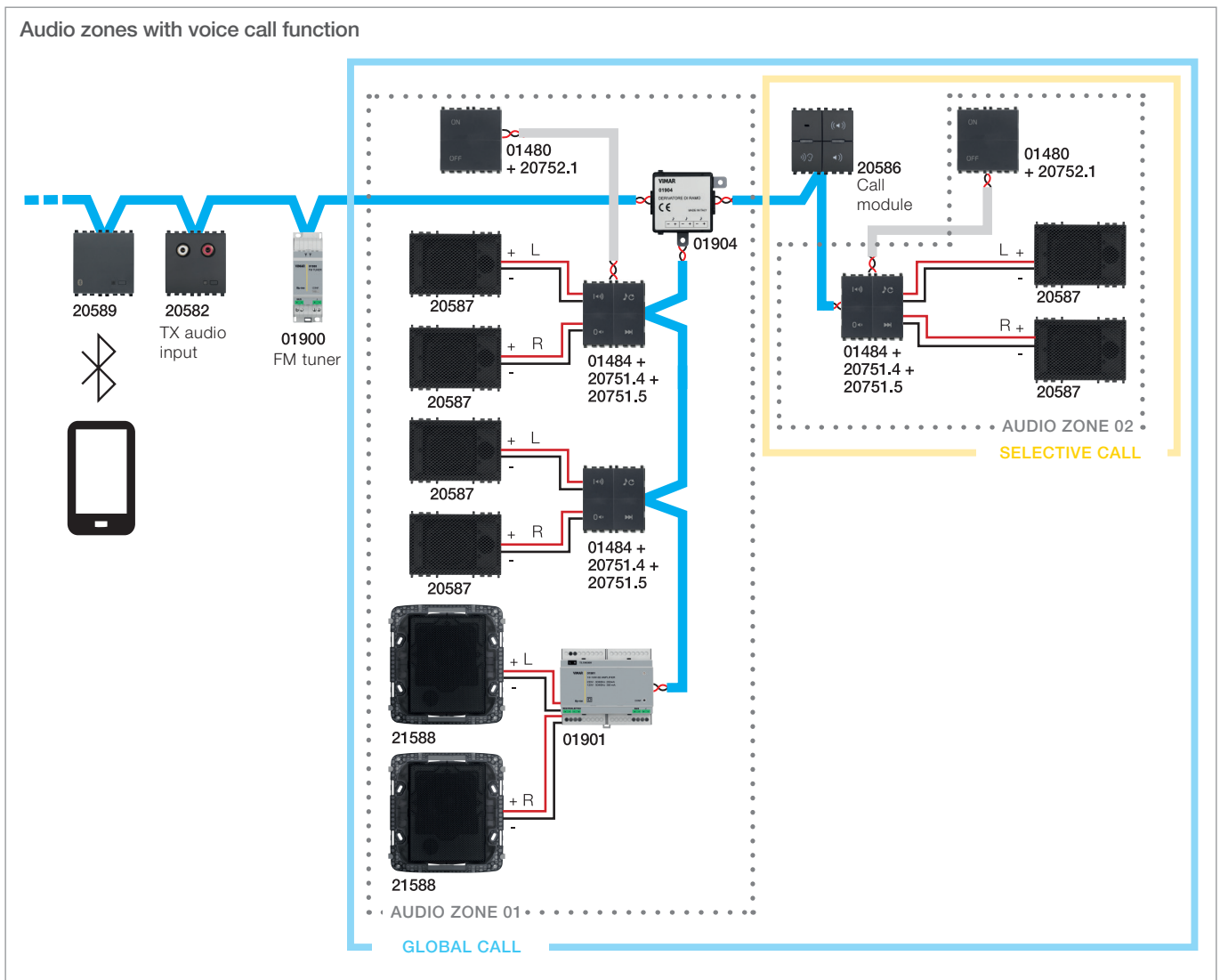

Devices configured: 1x audio input 20582, 1x FM tuner 01900 and 1x *Bluetooth technology* interface 20589 (transmitter modules), 4x audio amplifiers 30484-01484 and 01901 (receiver modules) with the related control buttons 20751.4 and 20751.5, 2x By-me controls 30480-01480 and 1x call module 20586.

Applications created: three for the transmitter modules, one for the call module and two for the receiver modules, with control devices.

Zones created: two audio zones paired with two groups of receivers.

Operation: the two zones work independently to play the audio channels. The selective call zone setting parameter must first be defined in the call module.

At the time of the call the voice message replaces the sound source being played at that moment.

On pressing the general call (global call) button this will be transmitted throughout all the present zones; on pressing the selective call button it will be transmitted only in the Audio 02 Zone.

Sound system

7.8.3 Audio zones with Baby Control function

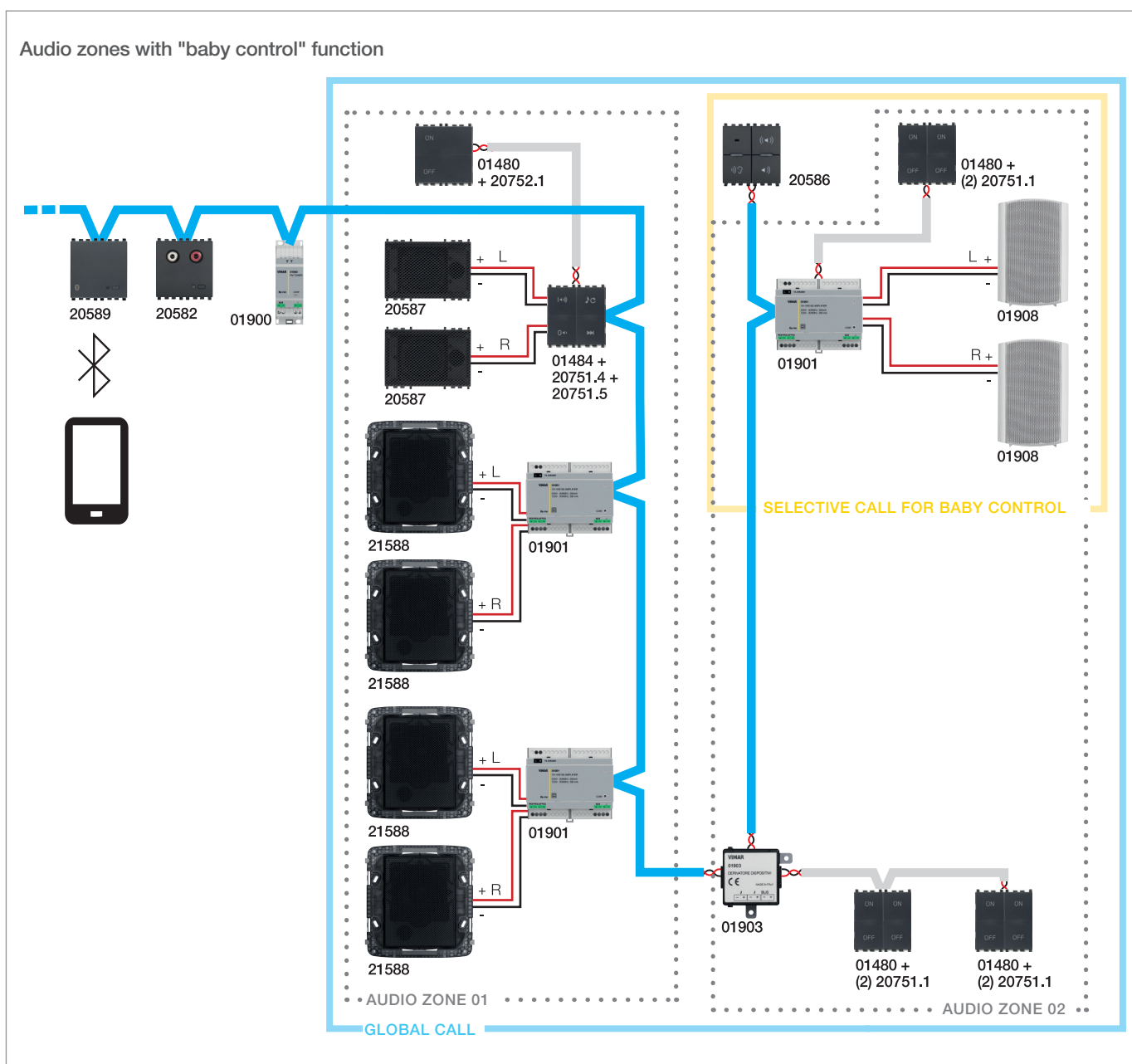

This example illustrates a typical installation in which one or more zones can play the audio source coming from the transmitter modules.

Devices configured: 1x audio input 20582, 1x FM tuner 01900 and 1x *Bluetooth technology* interface 30495-20589 (transmitter modules), 4x audio amplifiers 30484-01484 and 01901 (receiver modules) with the related controls 20751.4 and 20751.5, 4x By-me controls 30480-01480 and 1x call microphone module 20586 (transmitter).

Applications created: three for the transmitter modules, one for the call module and two for the receiver modules, with control buttons.

Zones created: two audio zones paired with two groups of receivers

Operation: the two zones work independently to play the audio channels.

The "baby control" call zone setting parameter must first be defined in the call microphone module. To enable the "Baby Control" function in the call module it is sufficient to press the relevant button on the module. At the time of the "Baby Control" call the voice message stops and replaces the sound source being played at that moment in the Audio 02 Zone.

Sound system

7.8.4 Audio zones with audio monitoring function

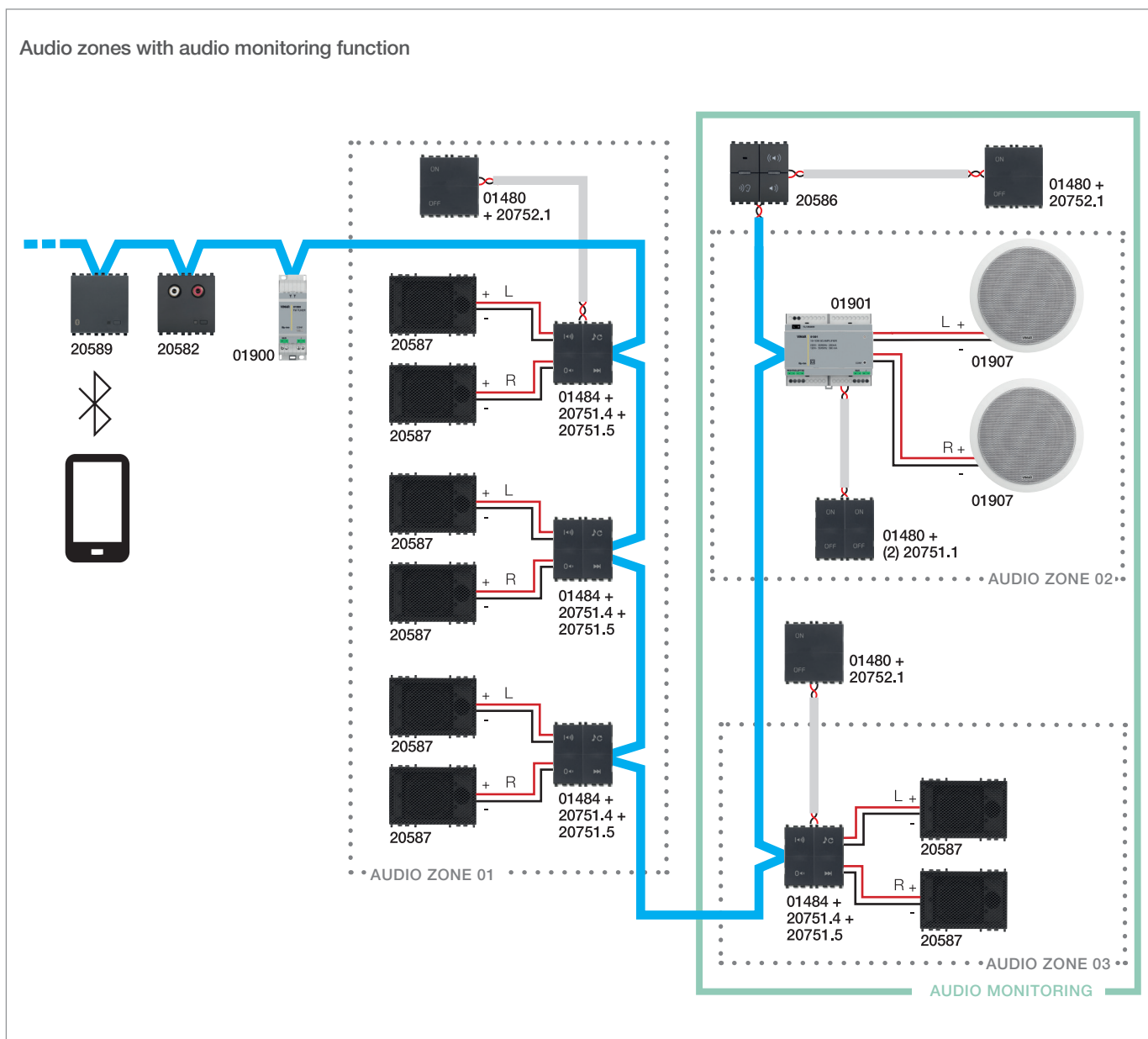

Devices configured: 1x audio input 20582, 1x FM tuner 01900 and 1x *Bluetooth technology* interface 30495-20589 (transmitter modules), 5x audio amplifiers 30484-01484 and 01901 (receiver modules) with the related controls 20751.4 and 20751.5, 3x By-me controls 30480-01480 and 1x call microphone module 20586 (transmitter).

Applications created: three for the transmitter modules, one for the call module with the audio monitoring control and three for the receiver modules with the paired controls.

Zones created: three audio zones paired with three groups of receivers.

Operation: the three zones work independently to play the audio channels; zones 02 and 03 are also dedicated to audio monitoring. The audio monitoring call zone setting parameter must first be defined in the call module. To enable the audio monitoring function it is necessary to have configured the relevant On/Off control button in the application containing the call module; on pressing the button the sound acquired by the microphone at that moment is played only in the Audio Zone 02 and 03.

Sound system

7.8.5 Audio zones with voice call function

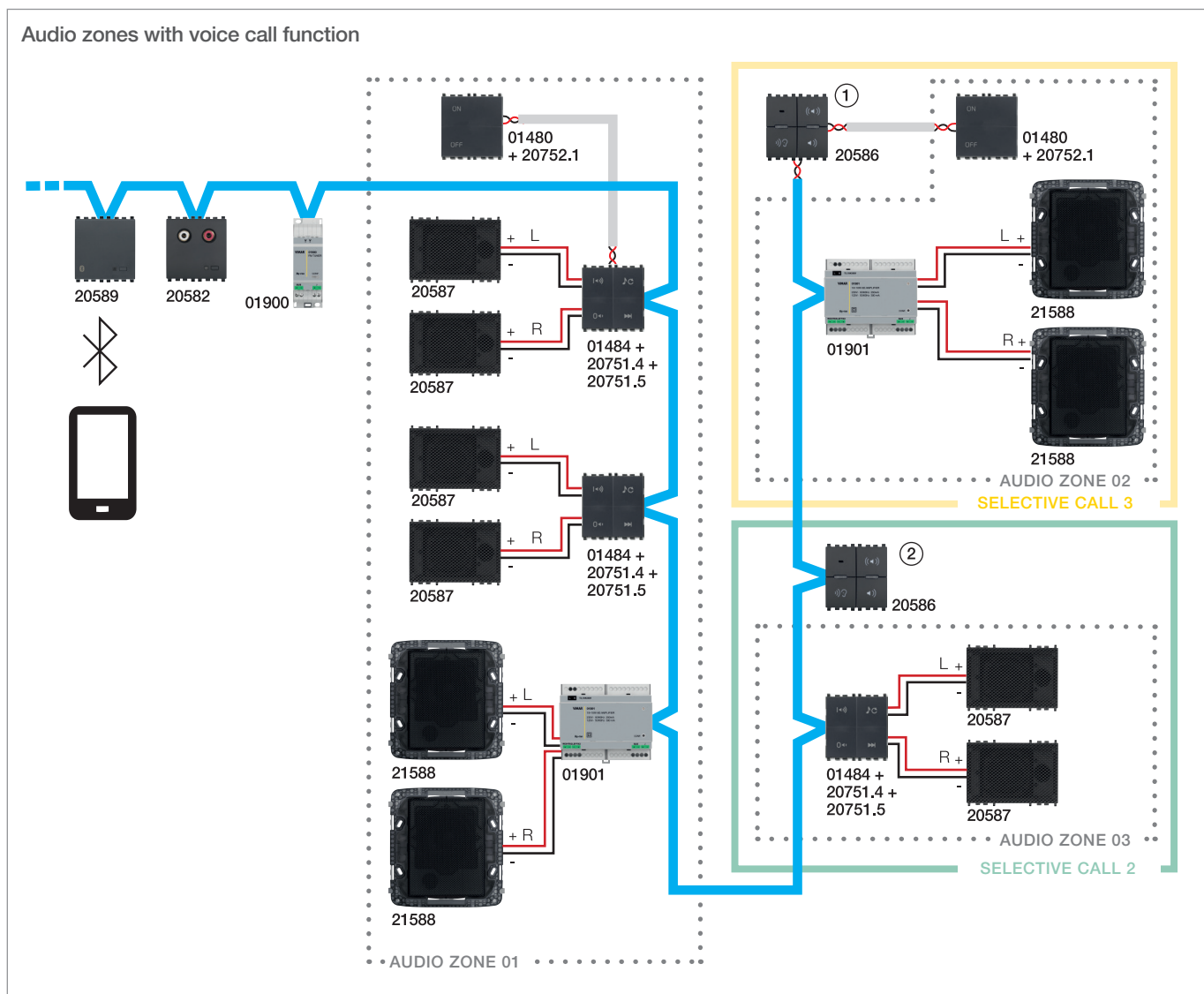

Devices configured: 1x audio input 20582, 1x FM tuner 01900 and 1x *Bluetooth technology* interface 30495-20589 (transmitter modules), 5x audio amplifiers 30484-01484 and 01901 (receiver modules) with the related controls 20751.4 and 20751.5, 2x By-me controls 30480-01480 and 2x call microphone modules 20586 (transmitters).

Applications created: three for the transmitter modules, two for the call modules and three for the receiver modules with the paired controls.

Zones created: three audio zones paired with three groups of receivers.

Operation: the three zones work independently to play the audio channels. The call modules no. 1 and no. 2 are located respectively in the same environment where there are the speakers of the audio zones 02 and 03.

The selective call zone setting parameter must first be defined on the call modules; in this case audio zone 03 will be set on module no. 1 and audio zone 02 will be set on module no. 2.

At the time of the call the voice message replaces the sound source being played at that moment.

On pressing the selective call button of module 1, this will be transmitted only in Audio Zone 03; likewise on pressing the selective call button of module 2, this will be transmitted only in Audio Zone 02 (selective call zone setting parameter). This way, when necessary, it is possible to communicate in a unidirectional manner between two different environments. This is half-duplex communication since the channel assigned to the call is unequivocal and therefore shared by the two configured modules; clearly, as long as the first call module is active it will not be possible to activate the second one, and vice-versa.

Sound system

7.8.7 Amplifier with *Bluetooth technology* receiver not connected to the bus and sound system

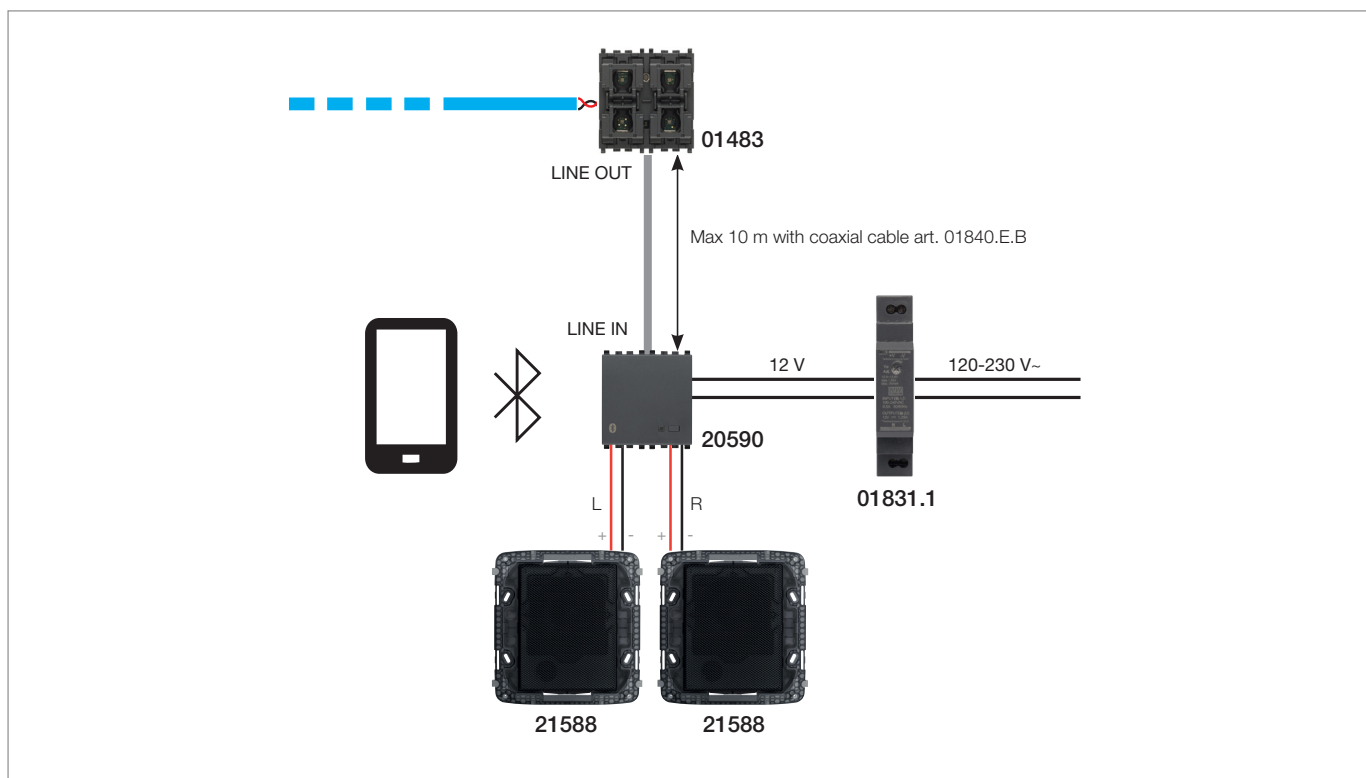

- The amplifier with integrated *Bluetooth technology* receiver 20590 is not connected to the sound system bus, whereas control device 01483 (connected to the amplifier 20590 via the LINE OUT output) is connected to the bus.
- In this type of installation, the amplifier 20590 with *Bluetooth technology* receiver does not take up any of the 4 available channels of the sound system.
- The amplifier 20590 with *Bluetooth technology* receiver is switched on and off using the push button on the front of the device.
- By default, the audio signal on the *Bluetooth technology* receiver has priority over any input signal at the LINE IN.

Sound system

7.8.8 Bluetooth technology interface connected to the sound system bus

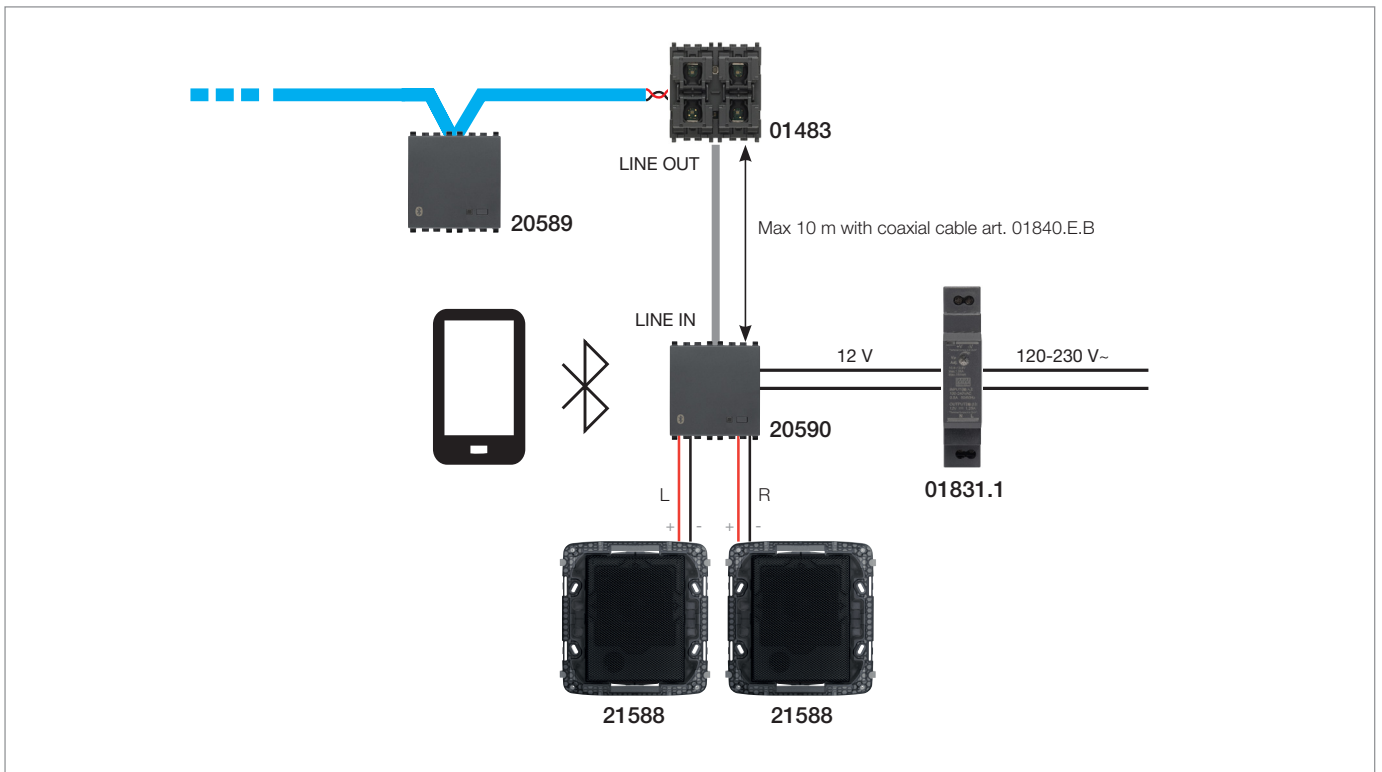

- The *Bluetooth technology* interface 30495-20589 is connected to the sound system bus and thus occupies one of the system's four channels.
- The *Bluetooth technology* interface 30495-20589 can be switched on and off by the receivers on the bus according to the registering/unregistering logic, in the same way as other transmitters.
- Any amplifier 20590 with *Bluetooth technology* receiver is switched on and off using the push button on the front of the device.
- By default, the audio signal on the *Bluetooth technology* receiver has priority over any input signal at the LINE IN. In practice, if an audio signal reaches the *Bluetooth technology* receiver of the amplifier 20590 while it is playing on LINE IN, the latter is muted, and the signal received via *Bluetooth technology* is played.

Sound system

7.8.9 Bluetooth technology interface connected to the sound system bus and third-party amplifier

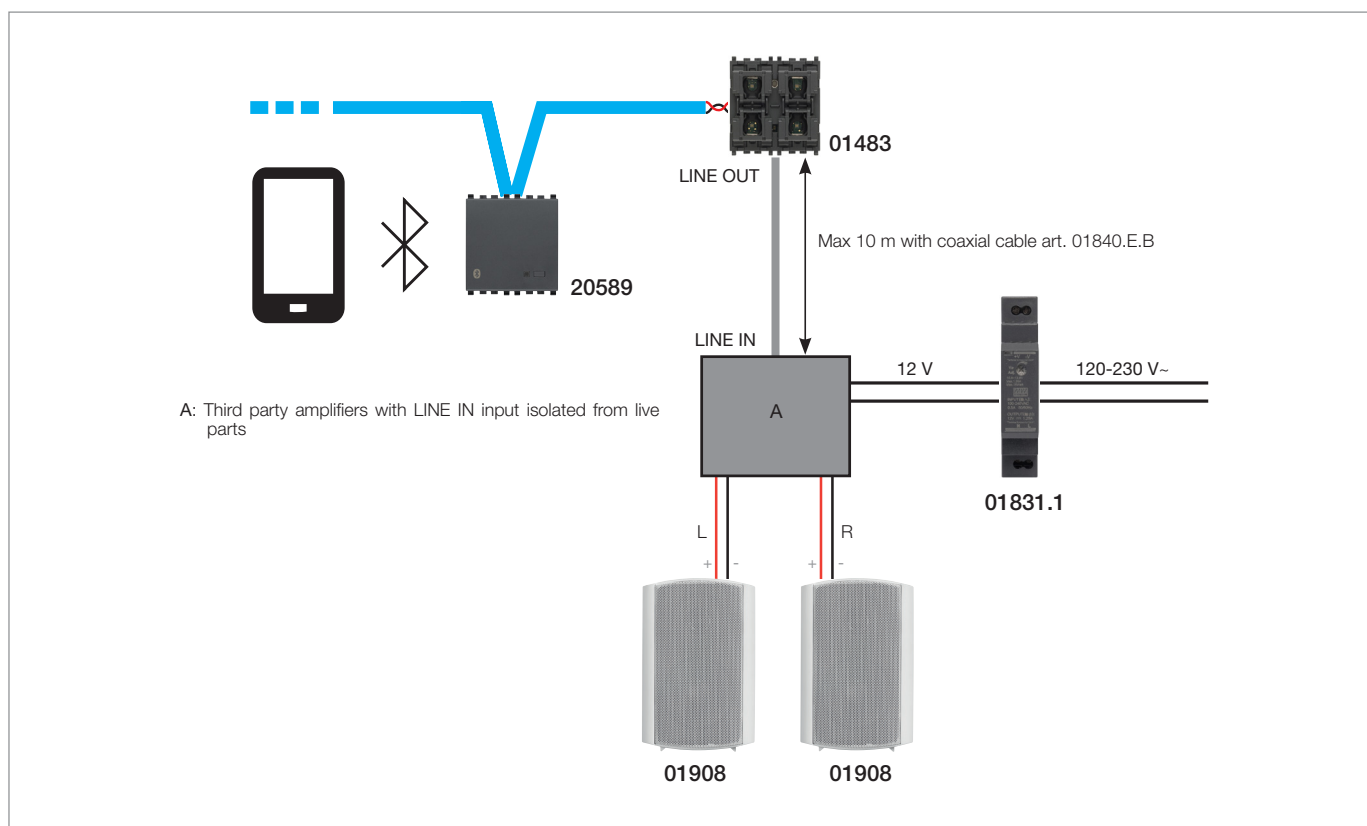

- The *Bluetooth technology* interface 30495-20589 is connected to the sound system bus and thus occupies one of the system's four channels.
- The *Bluetooth technology* interface 30495-20589 can be switched on and off by the receivers on the bus according to the registering/unregistering logic, in the same way as other transmitters.
- Third-party amplifiers play the audio signal that reaches the LINE IN input.

8. ENERGY MANAGEMENT

8.1 General characteristics

The Energy management functions of the By-me system allow you to control the consumption of your system and see both instantaneous values and historical values of the electrical and other (water, gas) measurements.

The functions are organised in three main menus:

- **Load control:** operating via the load control module 01455, this allows the user to monitor the amount of electricity being consumed in order to prevent meter overload breaker tripping and, if necessary, disconnect the monitored loads according to their priority. Single-phase systems of up to 33 kW and three-phase systems of up to 100 kW can be managed with or without production of photovoltaic energy and with a maximum of 16 priority groups.
- **Measurement control:** the By-me Plus system can be used to make up to a maximum of 40 measurements. Taking into account the type of system, you can determine the number of measurements already “occupied” by the load control and those that are still “free” and usable by the meters and pulse counters using the following table:

Type of application	Total no.
Single-phase load control without production	1
Single-phase load control with local production	5
Single-phase load control with remote production	5
Three-phase load control without production	4
Three-phase load control with production on one line	14
Three-phase load control with production on two lines	17
Three-phase load control with production on three lines	20
Single-phase meter	1
Three-phase meter	4
Pulse Counter	1

Examples:

- 1) In the case of single-phase load control without production (occupies 1) there will be 39 “free” measurements that can be distributed among the single-phase and three-phase meters and pulse counters (for example 10 single-phase meters - 6 three-phase meters - 5 pulse counters or 15 single-phase meters - 6 three-phase meters, etc.).
- 2) In the case of three-phase load control with production on three lines (occupies 20) there will be 20 “free” measurements that can be distributed among the single-phase and three-phase meters and pulse counters (for example 4 three-phase meters - 4 pulse counters or 4 single-phase meters - 3 three-phase meters - 3 pulse counters, etc.).
- 2) In the case of single-phase load control with local production (occupies 5) there will be 35 “free” measurements that can be distributed among the single-phase and three-phase meters and pulse counters (for example 2 single-phase meters - 8 three-phase meters - 1 pulse counter or 8 single-phase meters - 5 three-phase meters - 7 pulse counters, etc.).



- **Alarms management:** the groups in which the actuators are configured can be displayed showing the measurement of the current (art. 01456, 30474-20537-19537-14537) and any alarms that might be tripped by these actuators can be displayed and/or reset.

To check on power consumption, while also taking account of energy that may be produced by a photovoltaic system, the load control module 01455 must be installed and it is managed in the same way as the other devices in the system.





The load control module 01455 can restore disconnected services automatically, as soon as the total energy absorption of the system returns to a level below the set level.

8.2 Devices and functions

The devices that enable the Energy Management functions are as follows:

	<p>01450: Energy meter with 3 inputs for toroidal current sensor, detectable power 25 W-100 kW, single-phase power supply 120-230 V 50/60 Hz three-phase 230/400 V 50/60 Hz, installation on DIN rail (60715 TH35), occupies 1 module measuring 17.5 mm. Supplied with a toroidal current sensor.</p> <p>This device measures the power in one or more lines of a network. It can work on both single- and three-phase systems and can independently monitor up to 3 electrical lines. The current on the electrical line to be monitored is measured with a current sensor (art. 01457, 01458). Lastly, it saves the history of the energy values of each of the lines.</p>
	<p>01451: Energy meter with built-in current sensor, detectable power up to 3680 W, flush mounting (retrofit).</p> <p>The device measures the consumption of a load powered by the electrical line. The consumption data such as power and energy dissipation are displayed on the touch screens.</p>

Energy management

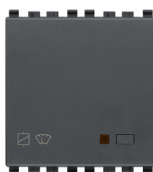
	<p>01455: Load control module, 3 inputs for toroidal current sensor, detectable power 25 W-100 kW, single-phase power supply 120-230 V 50/60 Hz three-phase 230/400 V 50/60 Hz, installation on DIN rail (60715 TH35), occupies 1 module measuring 17.5 mm.</p> <p>The device prevents the 1-way switch in the electricity meter from tripping due to overload; it can operate on both single-phase and three-phase systems. The current on the electrical line to be monitored is measured with a current sensor (art. 01457, 01458) and is capable of controlling up to 3 electrical lines independently. It is intended for systems including an energy production (e.g. photovoltaic) section. If the line cable is not easily accessible, the measurement can be made remotely by means of the energy meter (art. 01450) connected to the By-me bus. Lastly, it saves the history of the energy values of each of the lines.</p>
	<p>01456: Actuator with relay output 16 A 120-230 V~ 50/60 Hz with integrated current sensor, 1 input channel for toroidal residual current sensor, DIN rail installation (60715 TH35), occupies 1 module measuring 17.5 mm. Supplied without toroidal residual current sensor art. 01459.</p> <p>The device performs the function of an actuator and measures the power consumption; it also enables alarm signalling due to malfunctioning such as current leakage and load faults. The device can be used in automation, energy saving and HVAC management systems. It can also be used in systems where the old load control module 01855 is installed.</p>
	<p>01457: Toroidal current sensor for load control and energy metering, hole diameter 7.5 mm, cable length 40 cm.</p>
	<p>01458: Toroidal current sensor for load control and energy metering, hole diameter 19 mm, cable length 40 cm.</p>
	<p>01459: Toroidal residual current sensor for actuator 01456, hole diameter 9 mm, cable length 40 cm</p>
	<p>30474-20537-19537-14537: Actuator with relay output 16 A 230 V ~ 50 Hz with integrated current sensor - 2 modules</p> <p>The device performs the function of an actuator and measures the power consumption; it also enables alarm signalling due to malfunctioning such as current leakage and load faults. The device can be used in automation, energy saving and HVAC management systems.</p>

8.3 Load control

The load control module 01455 allows the user to monitor the amount of electricity being consumed in order to prevent meter overload breaker tripping and, if necessary, disconnect the monitored loads according to their priority.

The following systems can be controlled (with or without production of photovoltaic energy):

- single-phase systems up to 33 kW
- three-phase systems up to 100 kW

Up to 16 control groups can be controlled (equivalent to 16 priorities).

Each control group (which must necessarily include module 01455 and a By-me relay actuator) can be set in the following ways:

- **Auto OFF/ON:** automatic load connection and disconnection depending on the amount of power consumed and the group's priority
- **Forced ON:** load always on, irrespective of the absorption conditions.
- **Forced OFF:** load always off, irrespective of the absorption conditions.

For each group, you can select the **Auto OFF/ON** and **Forced ON** mode setting; with the events programmes you can then set one or more groups in **Forced OFF** mode (typically used to time the activation/deactivation of specific loads).

Each group can be paired with a rocker button, which can be used to force the setting to **Forced ON** (by pressing **ON** on the push button), the forcing is signalled by the permanently lit LED on the push button.

Press **OFF** on the group push button to return to **Auto OFF/ON** mode.

The load control system is configured as follows:

1. Configure the load control module art. 01455 in the specific group dedicated to electricity reading management.
2. Configure the meter art. 01450, if any, for the production of a "remote" system (i.e. far away from the ENEL meter) or when the meter is three-phase and single-/three-phase production also needs to be monitored. **This should only be done if a production system is already present**
3. Configure the various relays to monitor in the related groups together with art. 01455 where the first group configured should contain the most significant relay, and the last group configured should contain the least significant one, which will also be the first one to be disconnected.
4. Configure any external meters in the dedicated groups (for instance art. 01450 for remote photovoltaic or art. 01451-01456-30474-20537).
5. Insert the probe calibration data. The toroidal probes must be installed with the label facing the meter and not facing the system; this label contains 4 digits to be entered in the dedicated menu item in order to obtain an accurate measurement in the consumption log.

Energy management

6. Set the meter-thresholds for art. 01455 i.e.: minimum pre-alarm threshold (Threshold 1), maximum threshold which must under no circumstances be exceeded (Threshold 2), time interval during which the value of energy absorbed by the supplier is between "Threshold 1" and "Threshold 2" before the loads are disconnected and which, similarly, should pass between disconnections before a resetting attempt can be made (Threshold 2 Time).
7. Shift the relay disconnection priorities (to be done if you want to modify with respect to the order of creation of the relay groups configured previously).
8. In the LOAD CONTROL application, a relay can be configured in the Controller Group and/or Line Group, to which module 01455 sends an ON message as soon as the socket outlets begin to be disconnected and an OFF message when the socket outlets have all been restored.
9. Set the Auto-consumption management if you wish to activate a relay the moment the photovoltaic system begins to sell electricity to the supplier; this will minimise the energy sold so it can be used to activate an internal load, thereby incentivising auto-consumption, which is cheaper.

The diagram illustrated below shows an example of how the loads are switched off according to the thresholds and threshold times set.

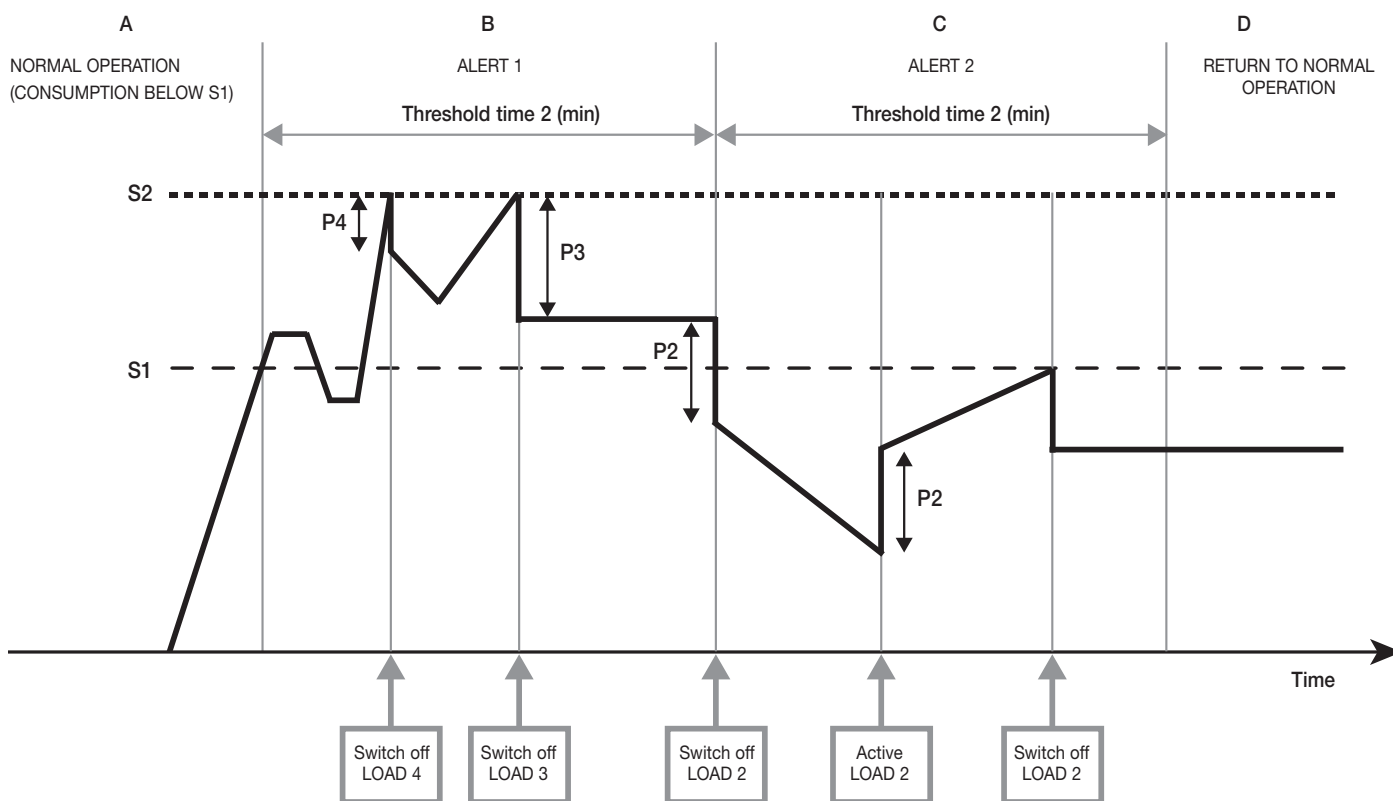

S1: Attention threshold

P4, P3, P2...: Consumption of loads 4, 3, 2.. (they are switched off in order of decreasing priority)

S2: Maximum power draw threshold

- A. In the absence of an overload (consumption below S1) operation is normal.
- B. If the consumption exceeds S1, the ALERT 1 phase is triggered, which lasts for the amount of time set on "Threshold Time 2" (default 90 min).
 - If the consumption exceeds S2 during the ALERT 1 phase, the lowest priority load (LOAD 4) is switched off; if this is not enough, the next one (LOAD 3) is switched off as well.
 - P4 and P3 are stored as the consumptions of loads 4 and 3 respectively, to be reactivated as soon as the conditions are right.
- C. At the end of the ALERT 1 phase, if the consumption is still above S1, the ALERT 2 phase is triggered, which also lasts for the amount of time set on "Threshold Time 2" and LOAD 2 is also switched off.
 - P2 is stored as the consumption of load 2.
 - If the consumption drops below S1 each of the loads is restored only if the consumption detected in the switch-off phase (for instance P2) is lower than S1.
- D. At the end of the ALERT 2 phase, if there are still loads that are switched off, NORMAL OPERATION resumes.
 - In NORMAL OPERATION, the system restarts the load switched off with the highest priority (P2 in the example), verifying the new consumption.
 - If the consumption exceeds S1 after restarting it, the ALERT 1 phase is activated again.
 - If by restarting the consumption does not exceed S1, the system restarts the next load with the highest priority, verifying once again the consumption compared to S1 (the procedure is therefore repeated for each of the switched off loads).

Note: If you want the device to intervene when a single threshold is exceeded, set "Threshold 1" = "Threshold 2".

Energy management

8.3.1 System examples

The following examples illustrate the types of system that can be configured using the View Pro App following the menus: APPLICATIONS -> ENERGY -> LOAD CONTROL.

SINGLE-PHASE SYSTEMS

Select SINGLE-PHASE and the type of system to configure.

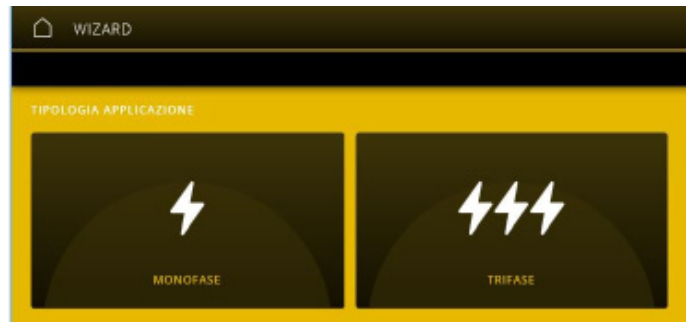

Energy management

■ Single-phase system WITHOUT PRODUCTION

In this case you can use the load control module 01455 combined with a current sensor

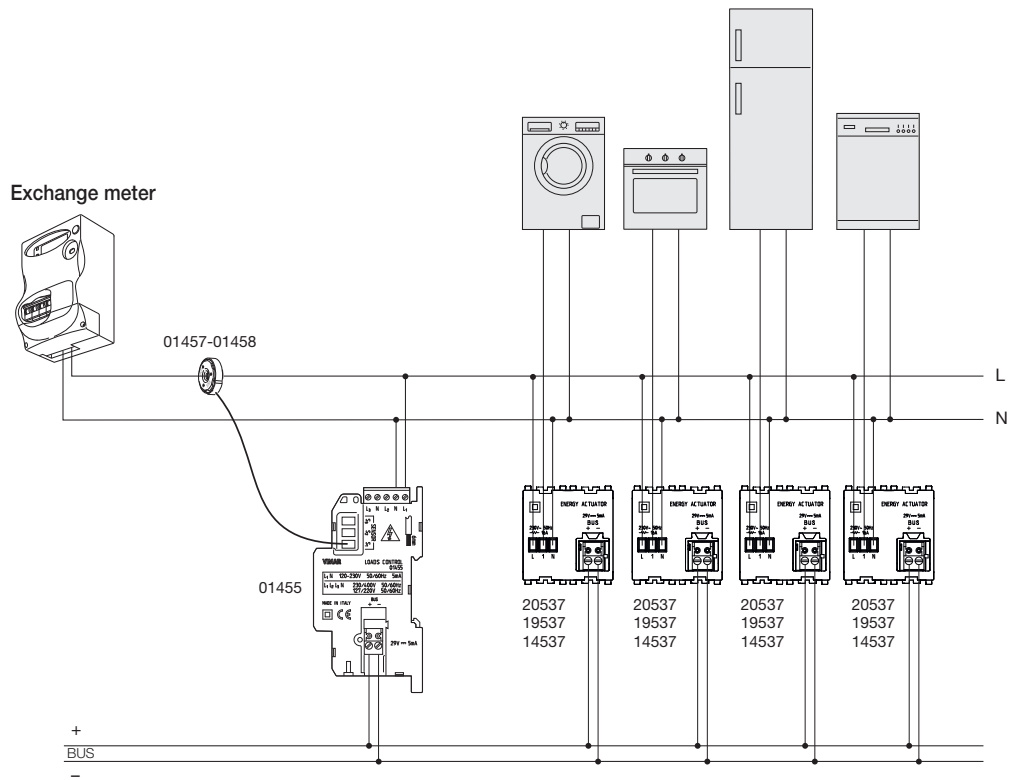

■ Single-phase system WITH LOCAL PRODUCTION

In this type of system the cable at the output of the production meter does not go to the same control unit where there is also the exchange meter cable.

In this case you can simply use just the load control module 01455 connecting the sensor 1 to the exchange meter and the sensor 2 to the production meter as shown in the figure below.

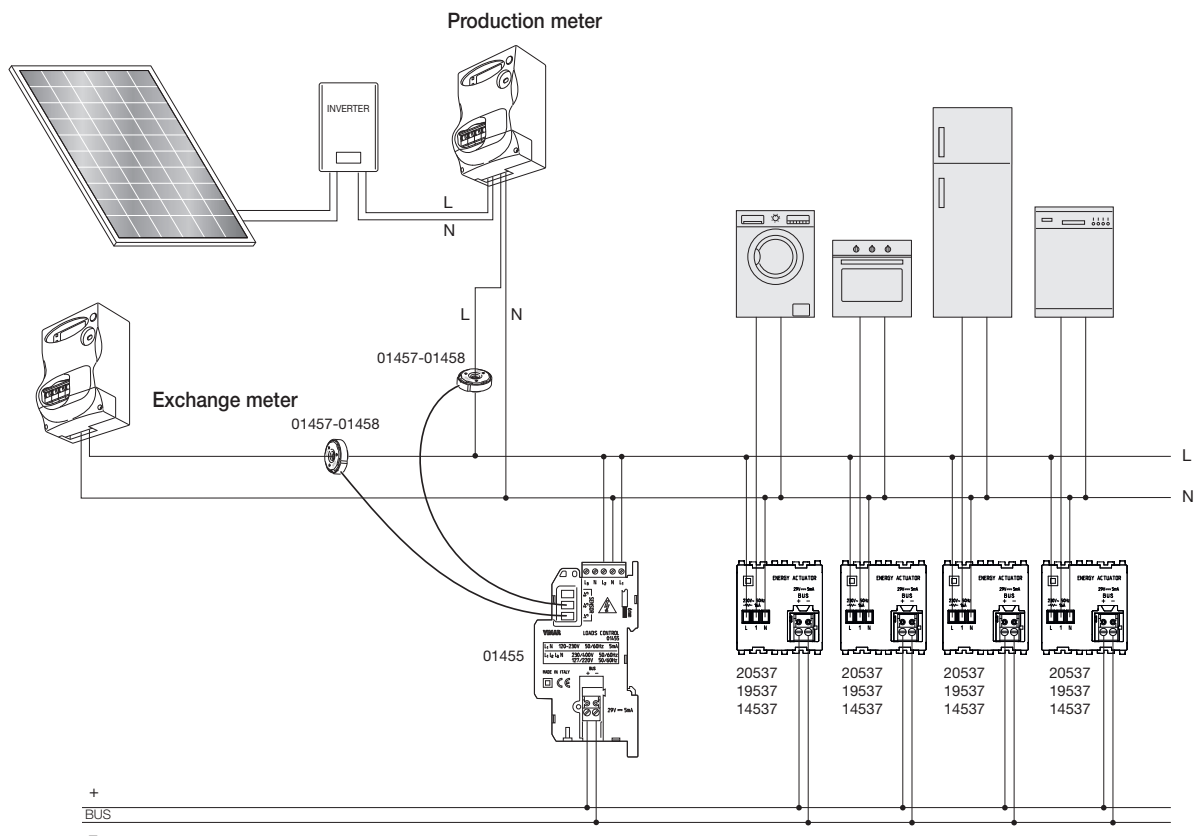

Energy management

■ Single-phase system WITH REMOTE PRODUCTION

In this type of system the cable at the output of the production meter does not go to the same control unit where there is also the exchange meter cable. Therefore, you cannot directly use the 2 current sensors on the load control module 01455 (the sensor cable is 40 cm long) but you need to install an energy meter 01450 to measure the current produced (as shown in the figure below).

Exchange meter

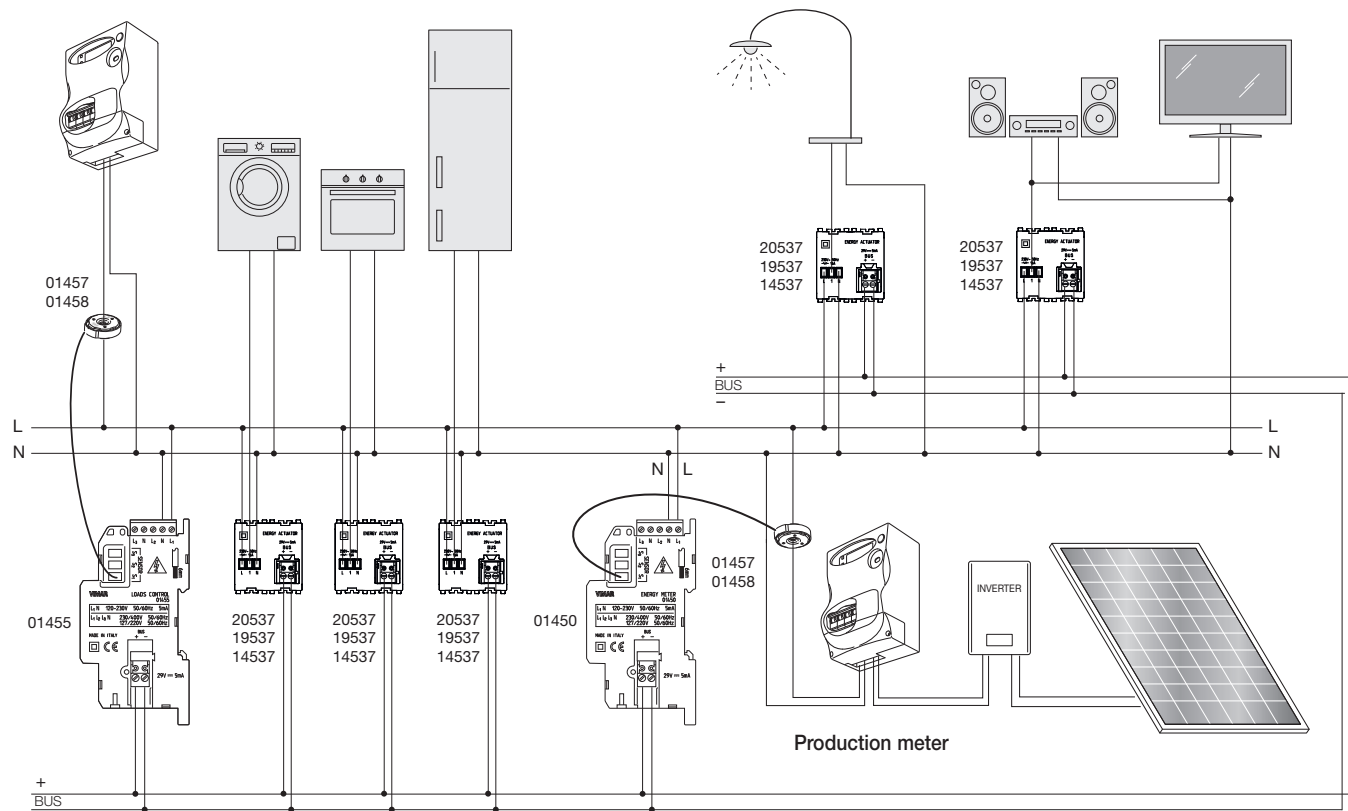

Energy management

THREE-PHASE SYSTEMS

Select THREE-PHASE and the type of system to configure.

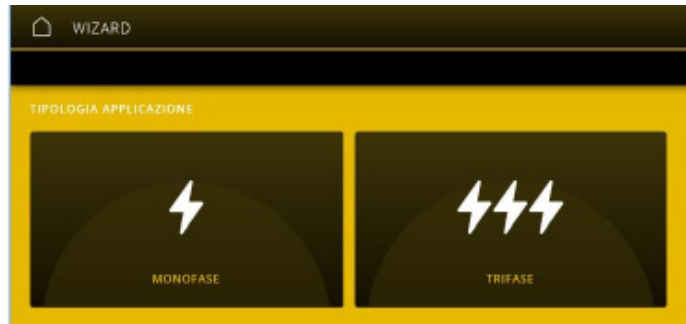

■ Three-phase system without production

In this case you can use the load control module 01455 combined with three current sensors (see figure below).

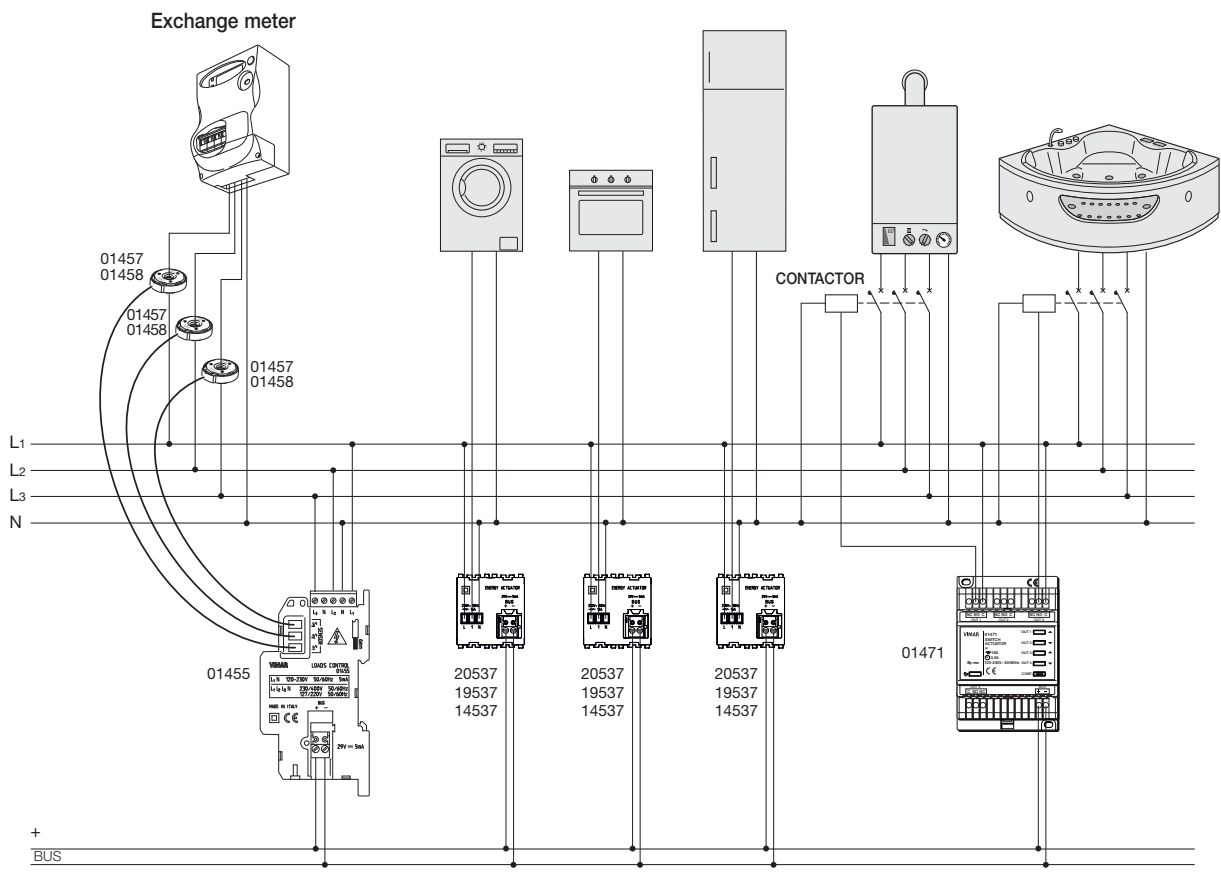

Energy management

■ Three-phase system with production (from one to three phases)

In this case you need to use the load control module 01455 (combined with 3 current sensors) to measure the exchange current and the energy meter 01450 (to measure the current produced (with one current sensor for each phase of the production meter).

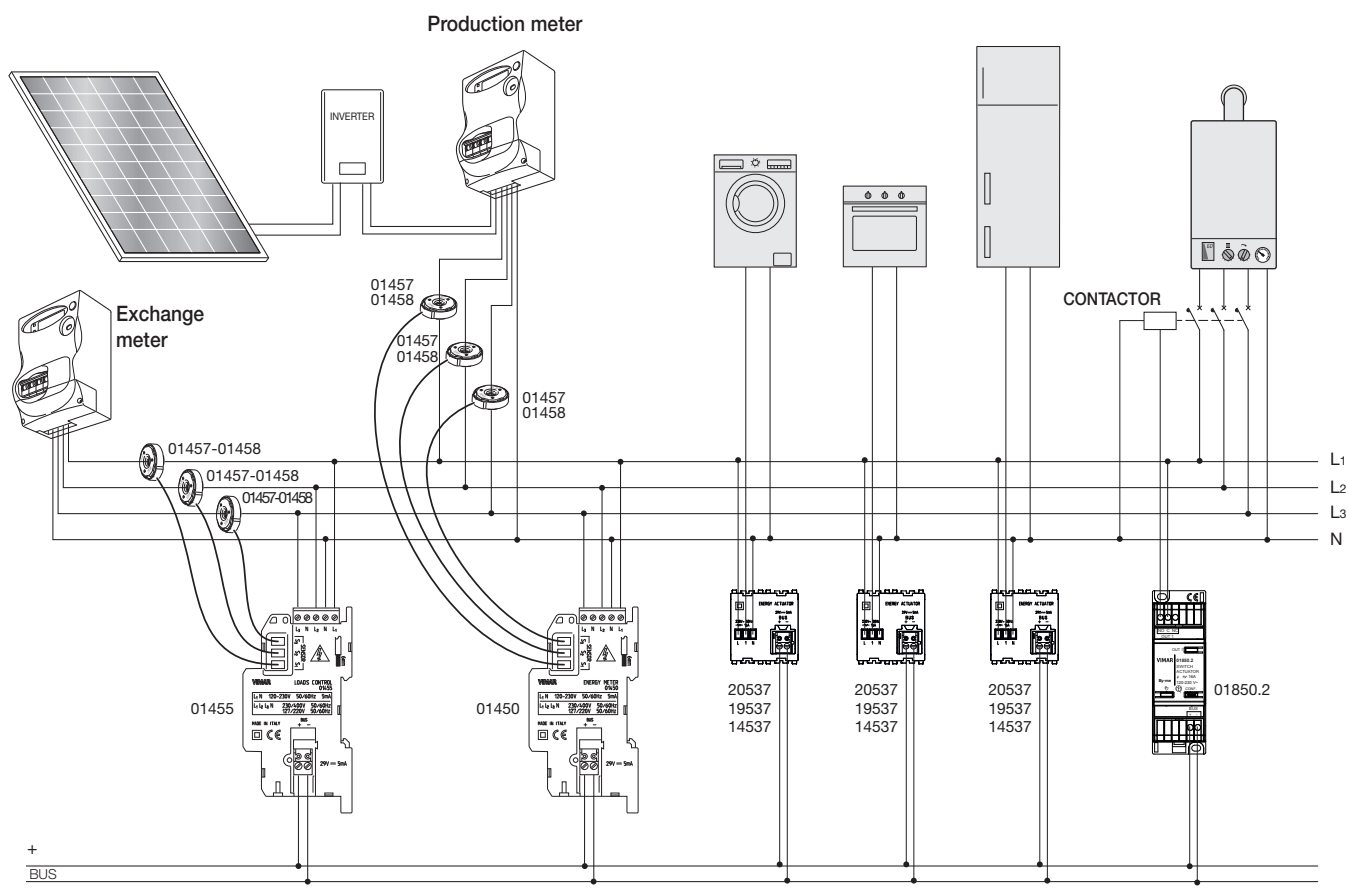

8.3.2 Installation of sensors art. 01457-01458

There are two types of sensors that can be used and configured in the Energy Management system:

- 01457: Toroidal sensor 7.5 mm for measurements of up to 10 kW
- 01458: Toroidal sensor 19 mm for measurements of up to 33 kW

IMPORTANT: 01457 and 01458 type sensors must be installed by facing the side on which the distinctive label is glued towards the fiscal meter or the meter paired with production.

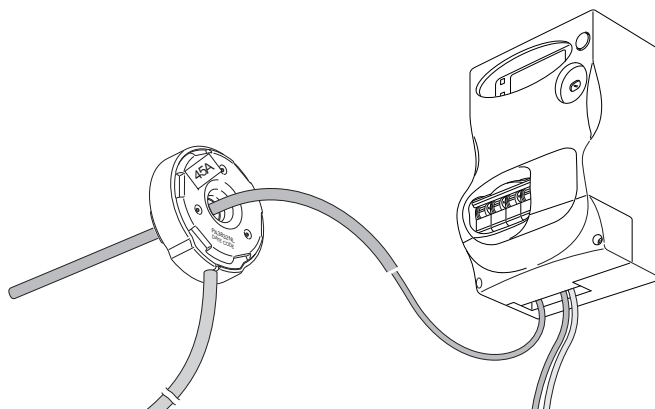

Energy management

8.4 Device parameters

For each device, the settings that can be configured directly from the View Pro App are the following:

- **ENERGY METER art. 01450**

- **Measurement refresh duration:** time interval during which the energy meter sends the power values to a display device (such as a touch screen) with a frequency equal to the set "Measurement refresh frequency". Values can be set from 20 to 120 s.
- **Measurement refresh frequency:** frequency with which the energy meter, during the "Measurement refresh duration" time interval, sends the power values of the display device (such as a touch screen). Values can be set from 1 to 10 s.
- **Reset value:** allows you to set the initial value of the measured energy which will then be updated as time passes.
- **Sensor setting:** displays a screen that allows you to set:
 - the **Type of sensor** → *Select the article code for the sensor (for instance, art. 01457)*
 - the **Calibration** → *Enter the value shown on the sensor's label (for instance, 40E)*

Confirm with **Set** and save with **Save**.

- **SINGLE LOAD CONSUMPTION METER art. 01451**

- **Measurement refresh duration:** time interval during which the energy meter sends the power values to a display device (such as a touch screen) with a frequency equal to the set "Measurement refresh frequency". Values can be set from 20 to 120 s.
- **Measurement refresh frequency:** frequency with which the energy meter, during the "Measurement refresh duration" time interval, sends the power values of the display device (such as a touch screen). Values can be set from 1 to 10 s.
- **Reset value:** allows you to set the initial value of the measured energy which will then be updated as time passes.

- **PULSE COUNTER INTERFACE art. 01452**

- **Divisor:** typical pulse generator parameter. Values can be set from 1 to 65535.
- **Multiplier:** typical pulse generator parameter. Values can be set from 1 to 65535.
- **Minimum pulse duration:** minimum detectable pulse duration. Values can be set from 2 to 250 ms.
- **Variable:** used to select the physical variable to measure (water, gas, etc.).
- **Reset value:** used to set the initial value to which the Pulse Counter Interface 01452 adds the number of the following pulses it has detected.

- **LOAD CONTROL MODULE art. 01455**

- **Load cut-off priority:** allows you to set the priority and therefore the order with which control groups are to be cut off. Values can be set from P1 to P16 (all different from one another).
- **Cut-off thresholds/Single line thresholds:** two thresholds S1 and S2 (with S2 greater than or equal to S1) for the entire system and two thresholds for the single line. These are the reference levels for the power consumption that determine cutting off loads; they must be configured according to the characteristics of the supply contract. Settable values:
 - S1: from 2.0 to 135.0 kW.
 - S2: from 2.0 to 150.0 kW.
- **Highest threshold validity time** (and on the single line): reference time for the validity of the highest threshold used for cutting off loads; it must be configured according to the characteristics of the supply contract. Values can be set from 20 to 200 min.
- **Measurement refresh duration:** time interval during which the energy meter sends the power values to a display device (such as a touch screen) with a frequency equal to the set "Measurement refresh frequency". Values can be set from 20 to 120 s.
- **Measurement refresh frequency:** frequency with which the energy meter, during the "Measurement refresh duration" time interval, sends the power values of the display device (such as a touch screen). Values can be set from 1 to 10 s.
- **Associated lines:** line to which the load you want to control is connected.
- **Production Threshold:** Parameter designed to manage one or more loads in auto-consumption mode; it is possible to set a minimum threshold of net power produced (i.e. in excess of that consumed) above which the load can be powered. Values can be set from 0 (function deactivated) to 33.0 KW. By setting a value above 0 KW, the load will only be activated in a condition of auto-consumption according to the threshold set; on the other hand, if it is necessary to activate the load in a condition of non auto-consumption, it is necessary to force the load itself via a dedicated button or via the App.

N.B. By properly configuring this parameter you can optimise energy management from the perspective of auto-consumption.

It is advisable to use this function by linking it to the value of the **Minimum power-on time**. In this way, the load control logic will allow switching on the load only with the set power produced and, even if it should then drop, it will keep the load in operation according to the set minimum time. Throughout this time, however, the overload power-down control will remain active.

To enable the auto-consumption function, set on **Load control** of a control group (among the 16 available in the Load control menu) the **Production threshold** parameter to the desired value and in any case slightly higher than the maximum consumption of the selected load. This way, the load is activated when the power introduced towards the operator exceeds the threshold and remains active for as long as the production exceeds the global consumption.

- **Minimum power-on time:** the load, once switched on, must remain ON for the **Minimum power-on time**. Values can be set from 0 to 300 min.
- **Minimum power-down time:** the load, once switched off, must remain OFF for the **Minimum power-down time**. Values can be set from 0 to 300 min.

• RELAY ACTUATOR art. 01456

- **Failure alarm mode:** used to enable the failure alarm. Settable values: 0 = alarm disabled, 1 = alarm enabled.

Note: The failure alarm must only be enabled on actuators to which are connected loads that have a constant minimum consumption; otherwise, there would be the risk of false alarms due to a load that does not consume not because of failure but because its ON operation is not always constant.

- **Failure alarm threshold:** minimum power value below which a failure alarm is signalled. Values can be set from 0 to 100 Watts.
- **Mode:** actuator operating mode that can be selected from **One-position stable** (return to OFF status after **On duration** seconds) or **Two-position stable** (status change with external control). Settable values: 0 = Two-position stable, 1 = One-position stable.
- **Leakage alarm mode:** leakage alarm operating mode. Settable values 0 = Alarm Disabled and reset, 1 = Alarm Enabled, i.e. the actuator status is constrained to the value of Auto OFF.
- **Leakage alarm threshold:** minimum leaked current value above which there is a "current leakage" alarm signal. Settable values: 6, 10 and 30 mA.
- **On delay:** delay in activating the ON control. During the **On delay** standby phases, a control that maintains this status resets the meters while an opposite control has no effect on meter initialisation. Settable values: from 0 to 11h 59min 59s.
- **Off delay:** delay in activating the OFF control. During the **Off delay** standby phases, a control that maintains this status resets the meters while an opposite control has no effect on meter initialisation. Settable values: from 0 to 11h 59min 59s.
- **On duration:** time for which the device is on; at the end of the set time the device switches off and sends the information on its status. It should only be taken into account on actions concerning the **TimedStartStop** and **DimmingInput** controls that determine the one-position stable behaviour of the actuator. Settable values: from 0 to 11h 59min 59s.
- **Auto off:** Enables or disables the device's relay automatic power-down function in the event of a leakage alarm; it is constrained by **Leakage alarm mode=1**. Settable values: 0=**Auto off** disabled, 1= **Auto off** enabled.
- **Scenario delay:** delay in actuating the scenario. Values can be set from 0 to 10 s.

*Note: This parameter is used when in actuating a scenario there is to be the simultaneous activation of different actuators. To avoid a high inrush current due to the power-on of multiple devices simultaneously, the actuators are activated in rapid sequence, each with a default delay time (**Scenario delay**) after receiving the control; the entire activation sequence can then take up to approximately 1 hour and 50 minutes. During the **PAR_ScenarioDelay** standby phase, receiving a group control, such as **SwitchOnOff**, **DimmingInput**, **TimedStartStop**, resets the meter inhibiting activation of the scenario.*

9. TEMPERATURE CONTROL

9.1 General characteristics



The By-me temperature control devices allow full control of the climate in every field of application (residential and tertiary) as they are used to manage even complex temperature control systems. The implementable solutions include heating and air conditioning of buildings with two or four pipes (with neutral zone management, where applicable), with underfloor heating and radiators, fan coils and split/multi-split systems; the systems can be managed in On/Off mode or with proportional control.

In environments with underfloor heating, with high thermal inertia which does not permit sudden variations in temperature, the innovative thermostat function termed “boost” or “auxiliary heating/air-conditioning” automatically starts any fan coils or towel heaters to reach the desired climate comfort quickly.



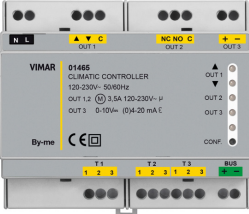
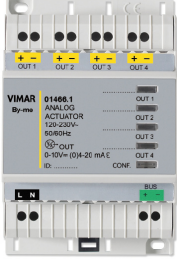

Special sensors monitor ambient humidity, to start the air recirculation or dehumidifiers; with underfloor cooling systems, it is also possible to prevent the formation of condensation, by modifying the boiler flow temperature.

9.2 Devices and functions

The devices that enable the temperature control functions are as follows:

	<p>01465: HVAC controller for heating systems, 120-230 V~ 50/60 Hz power supply, 3 inputs for PT100, PT1000 and NTC probes, 1 mixer valve control output, 1 output 0-10 V or (0)4-20 mA, 1 change-over relay output 8 A 230 V~, installation on DIN rails (60715 TH35), occupies 6 modules size 17.5 mm.</p> <p>The HVAC controller for heating systems manages the temperature control of the flow water in heating and cooling systems, if required also managing the outdoor ambient temperature. It has an On/Off output for circulation pump and a proportional and open-close mixer valve output. It can also be used to prevent dewpoint (condensation) in underfloor cooling systems, combined with the humidity sensor (and analogue interface)</p>
	<p>01466.1: Actuator with 4 proportional analogue outputs (0)4-20 mA or 0-10 V with re-scalable maximum output voltage or current, power supply 120-230 V~ 50/60 Hz, By-me home automation system, installation on DIN rails (60715 TH35), occupies 4 modules size 17.5 mm.</p> <p>Acting as a proportional actuator, the device can control/adjust the degree of opening of motorised proportional valves accepting variable control signals for voltage (e.g. 0-10 V) or current (e.g. 0-20 mA) It can control up to 4 independent loads.</p>
	<p>01467: Device with 3 analogue signal inputs, 1 input 0-10 V or 4-20 mA, 1 input for flush mounting or wired temperature NTC sensor, 1 input for brightness sensor 01530, for By-me home automation system, installation on DIN rails (60715 TH35), occupies 2 modules size 17.5 mm.</p> <p>The device has 3 inputs, divided as follows: 1 input for voltage sensor 0-10 V or current sensor 0-20 mA, 1 input for flush mounting or wired temperature NTC sensor and 1 input for brightness sensor (01530). The first input can be for voltage or current, and the selection is made only during the configuration phase. This lets you connect By-me devices with any probe with a standard voltage or current output. The inputs for the temperature or brightness sensor exclusively support only Vimar sensors. The brightness sensor provides energy savings because it lets you adjust the artificial light when there is sufficient natural light to reach the desired level, when fitted with a universal dimmer.</p>
	<p>02951: Touch screen home automation system thermostat for ON/OFF and PID temperature control (heating and air conditioning), 2- and 4-pipe management system, 3-speed and proportional fan coil control, 1 input for flush mounting or wired temperature NTC sensor, RGB LED backlighting, to be completed with Eikon Evo, Eikon, Arké or Plana - 2 module cover plates</p> <p>The thermostat is integrated with the By-me home automation system for temperature control in 2- or 4-pipe systems (heating/air conditioning) and neutral zone (4-pipe systems only), with “boost” or “auxiliary heating/air conditioning” function to run a second source to reach the desired thermal comfort quicker. The thermostat has an RGB back-lit display with 4 capacitive keys to control the temperature set point, fan coil speed and thermostat operation mode configuration; the display colour is adjusted via the App. The thermostat is a universal 2-module device, available with white or anthracite finish, which can be installed on the supports from the Eikon, Arké and Plana series.</p>

Temperature control

	<p>30471-02971: Home automation system dial thermostat for room temperature control (heating and air conditioning), 2- and 4-pipe system management, 3-speed and proportional fan coil control, class I temperature control device (contribution 1%) in ON/OFF mode, class IV (contribution 2%) in PID mode, can be interfaced with actuator with proportional analogue outputs 01466.1 to make a class V modulating room thermostat (contribution 3%), 1 input for electronic temperature sensor 20432, 19432 or 14432 or wired temperature sensor 02965.1, white LED backlighting, to be completed with Eikon, Arké or Plana cover plates - 2 modules. For Idea, can be installed using the dedicated mounting frame 16723.</p> <p>The thermostat is fitted with a front dial to adjust the setpoint (between 4°C and 40°C) and a central white LED display which shows the temperature measured, showing the setpoint only when the dial is being used. The circular ring around the display, with RGB backlighting, displays all the thermostat statuses. The device is fitted with 4 front buttons to be used for configuration and setting. The thermostat should be configured in the By-me Plus system using the View Pro App.</p>
	<p>20433-19433-14433: Electronic active humidity sensor, 1 output 0-10 V or 4-20 mA, power supply 12/24V - 2 modules. For integration with the By-me Plus home automation system via 01467.</p> <p>This device measures the relative humidity of the air in the room where it is installed and transmits the information via an analogue signal in voltage 0-10V or current 4-20 mA. Integration with the By-me system requires the combination with the analogue input of art. 01467.</p>
	<p>30478-20538-19538-14538: Probe for ON/OFF and PID temperature control (heating and air conditioning), 2- and 4-pipe management system, 3-speed and proportional fan coil control, 1 input for flush mounting or wired temperature NTC sensor, for By-me home automation system.</p> <p>In addition to all the display functions, the device is similar to the thermostat 02951 and is used for temperature control in 2- or 4-pipe systems (heating/air conditioning) and neutral zone (4-pipe systems only), with "boost" or "auxiliary heating/air conditioning" function to run a second source to reach the desired thermal comfort quicker.</p>
	<p>20584.1-19584.1-14584.1: Interface for transmission of By-me controls to IR receiver, for By-me home automation system, complete with 3 m cable.</p> <p>The IR interface is used to control audio sources (stereo combo, CD/DVD players, etc.) or split devices learning and emulating the controls of the original remote control of the equipment to control. Paired with an RCA transmitter (art. 20582-19582-14582) it therefore makes it possible to have sound sources controlled directly by the By-me system. Paired with thermostats, touch screens, the home automation system module 01965 and the gateways, it is used to control the split devices, either manually or through scenarios or events. The extension lead for the IR control is supplied as standard.</p>

9.3 Configuration

The main task to perform in order to configure the temperature control devices is to create applications (sets of functional units that need to work together) to which they are assigned.

9.3.1 Configuration of HVAC controller for heating systems 01465

The HVAC controller consists of:

- A Main functional unit (that must be configured first in an application dedicated to it).
- A Circulation pump functional unit (which must be configured in each application containing the Output functional units of the various thermostats).
- An External Temperature functional unit.
- An Auxiliary Temperature functional unit.
- A Humidity functional unit (employed to use the "anti-condensation" function).

Configuration of the Main functional unit

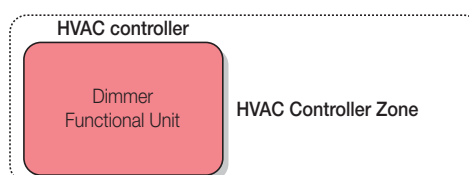

- Select the "Heating" or "Air conditioning" mode and set the type selecting among the following options:

- a) **Off:** disables the mode
- b) **Fixed:** the delivery temperature (T2), for both heating and air conditioning is kept constant at the value set in the set point. In this mode the external probe is not required.

Temperature control

c) **Modulating** (climatic): the delivery temperature (T2) is controlled according to the external temperature and the correction factor K according to the ratio:

$$\text{Delivery } T = \text{Set point} + K \times (\text{Set point} - \text{External } T)$$

The Set point and External T values are estimated during the installation and it is essential to give a limit to the Delivery T. Below is an example approach:

- Assuming you have an underfloor heating system, it is necessary to ensure that the temperature of the water circulating inside the pipes is not too high.
- So the delivery temperature limit set is: 35°C.
- Then an estimate on what could be the most unfavourable condition for the system is carried out (i.e. the condition in which it is necessary to heat up the environment a lot); then it is assumed that the external T rarely falls below 0°C and the set point set by the user almost never exceeds 20°C.
- Using the above ratio, the limit case estimated is 35°C = 20°C + K x (20°C - 0°C) which produces K = 0.75.
- With the K just determined, if the External T is always greater than or equal to 0°C and the set point is always less than or equal to 20°C, the Delivery T will never exceed 35°C.

For details on the correction factor K, see items **Air conditioning correction factor** and **Heating correction factor**.

- Select the type of **"Open/Close"** or **"Proportional"** valve.

If **Proportional** is selected it is necessary to set the type of output: **"Voltage"** or **"Current"**.

Configuration of the Circulation pump functional unit

The circulation pump unit can be configured:

- in applications where the output functional units of the thermostats 02951 are configured;
- in applications where the temperature probes 30478-20538-19538-14538 are configured;
- in applications where the thermostats 20514-19514-16954-14514 are installed.

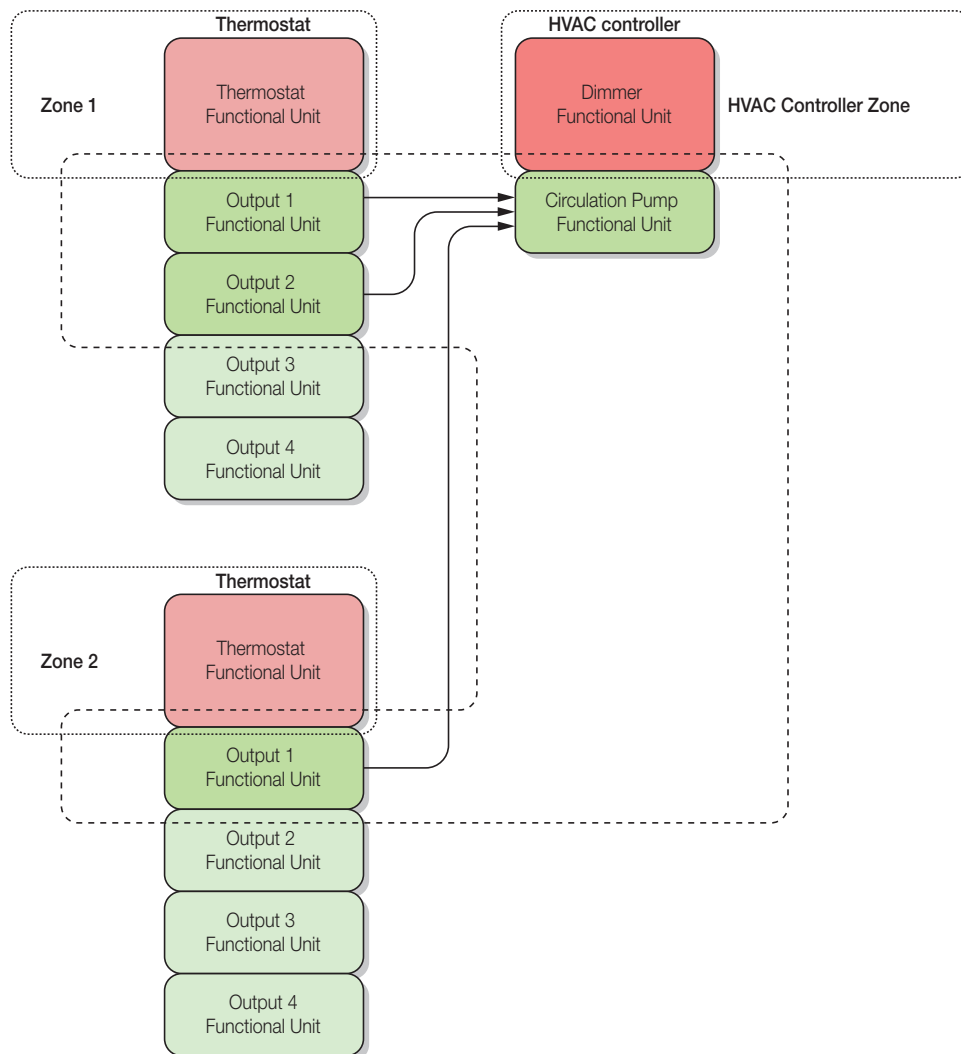

Temperature control

Configuration of the External Temperature functional unit

This functional unit can be used when one of the two modes, **Heating** or **Air conditioning** is set as **Modulating**.

The functional unit can be configured:

- integrating it in a group where there is the **NTC** functional unit of a 3-input device 01467 (the HVAC controller will receive the temperature value from the By-me bus as shown in the following figure);
- in an application dedicated to it (the HVAC controller will send on the By-me bus the temperature read by T1);
- in the same application as the **Main** functional unit (in this case it will provide only the external temperature value to be displayed in a touch screen, etc.).

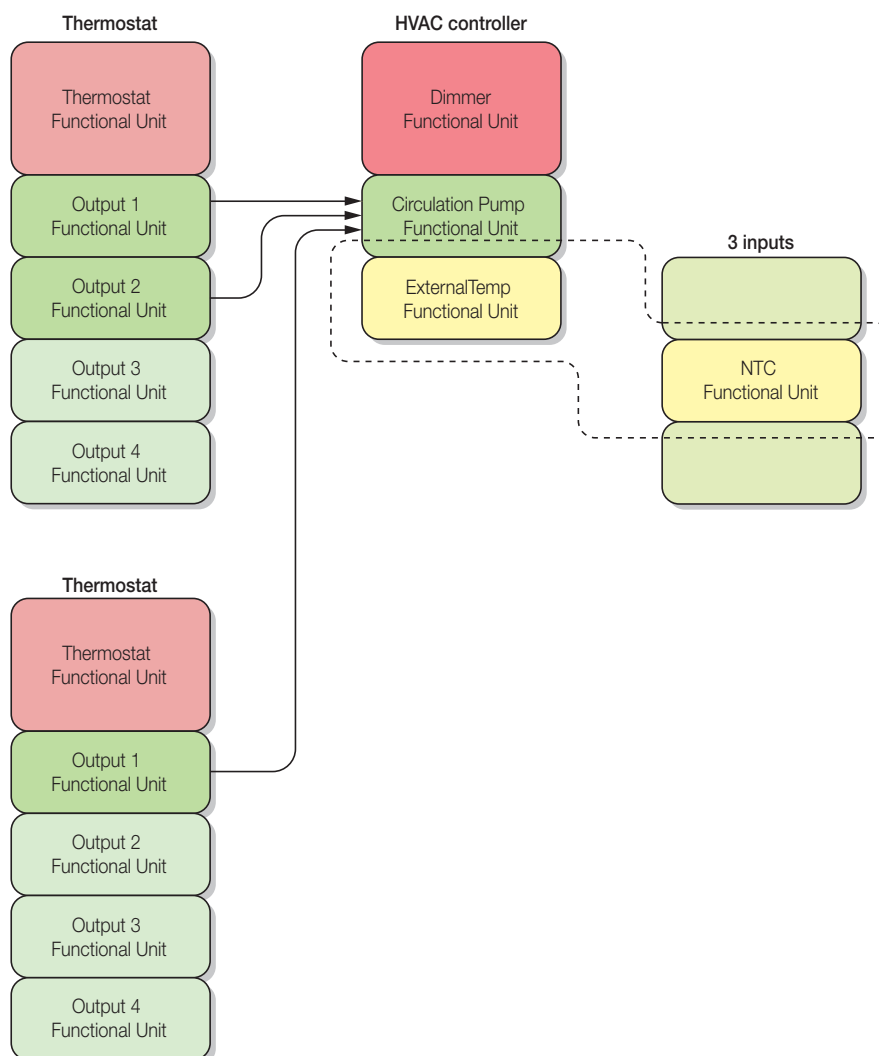

N.B.: When an **External Temperature** functional unit is configured in a dedicated application and this unit is the first to be configured, the controller (which has the probe physically connected at its terminals) is able to provide the external temperature to other controllers 01465; to do this, just set up later in the same application all the External Temperature units of the other controllers and they will use the measurement.

The configuration in empty groups of an HVAC controller that has the Main functional unit configured but the External Temperature and Auxiliary Temperature functional units that are not, activates the request in the whether to configure these units or not; if the operator chooses to continue, the configuration proceeds automatically without displaying additional requests.

Temperature control

Configuration of the Auxiliary Temperature functional unit (T3)

The Auxiliary Temperature unit can be configured:

- in a dedicated application (empty) simply to provide a temperature value to be displayed (for example in a touch screen);
- within an application where there is a main functional unit and therefore the T3 input is used as **Shut-down alarm input** (for notification of a possible shut-down alarm of the HVAC controller). See the following figure:

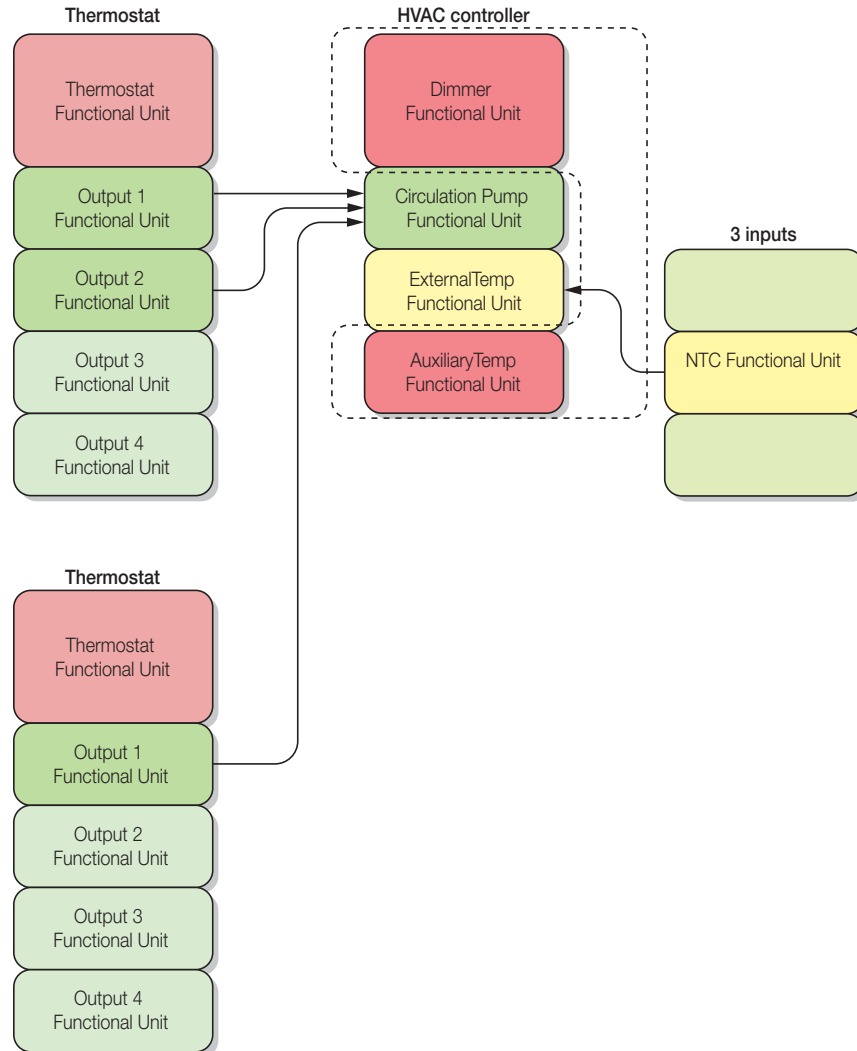

N.B.: The configuration in empty applications of an HVAC controller that has the Main functional unit configured but the External Temperature and Auxiliary Temperature functional units that are not, activates the request in the whether to configure these units or not; if the operator chooses to continue the configuration proceeds automatically without displaying additional requests.

Temperature control

Configuration of the Humidity functional unit

This functional unit is used when it is required to use the anti-condensation function of the controller in the case of an air conditioning system. The unit must be configured in an application in which there is the **General analogue input** functional unit of a 3-input device 01467 previously set as **Humidity sensor xx433**.

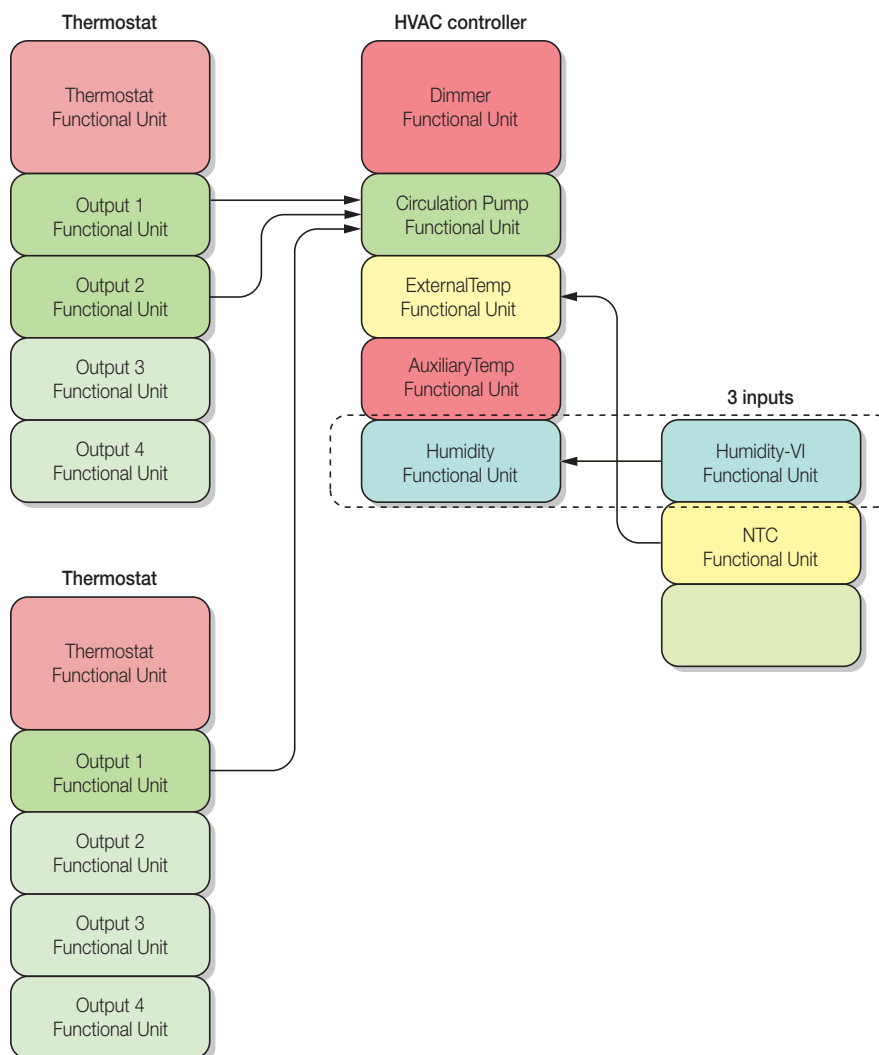

The anti-condensation function intervenes only in the air conditioning adjustment mode and it limits the value of the delivery temperature so that condensation does not develop in the environment; the calculation of the delivery temperature limit varies depending on the work mode:

- modulating work mode: the temperature limit is determined according to the desired temperature and the percentage of humidity detected.
- fixed work mode: the temperature limit is determined only as a function of the percentage of humidity detected as shown in the following table.

Humidity [%]	< 30	35	40	45	50	55	60	65	70	75	80	85	90	95	99	> 100
Temperature [°C]	10 (minimum programmable SetPoint)	11.2	13.2	15.1	16.8	18.3	19.7	21.1	22.2	23.3	24.3	25.1	26.2	27.1	27.8	28.0

CAUTION: This function cannot guarantee that no condensation forms in systems with underfloor or radiant panels cooling if they are subjected to sudden temperature changes (e.g. prolonged opening of a window, or starting the air conditioning in the presence of high ambient temperature and humidity); the high thermal inertia of such systems in fact does not in any case allow the avoidance of condensation unless accompanied by an adequate dehumidification system.

Note on automatic programmes:

The temperature values that are assigned by default to the automatic programmes are: T1-heat. = 15°C, T2-heat. = 18°C, T3-heat. = 20°C, T1-aircon. = 26°C, T2-aircon. = 28°C, T3-aircon. = 30°C.

In the case of a fixed work mode these values are obviously conservative and the installer will set them to the values appropriate to the delivery setpoint temperature.

Temperature control

9.3.2 Configuration of proportional analogue 4-output actuator 01466.1

Configuration of a temperature control application

The View Pro App displays the options defining the type.

Configuration of an automation application

Important: First configure the proportional output device and then the actuator and the By-me control.

The View Pro App displays the options defining the type.

9.3.3 Configuration of device with 3 analogue signal inputs 01467

The device consists of 3 functional units, i.e.:

1. General analogue input .
2. NTC (thermometer for NTC probe) .
3. Brightness dimmer (must be configured in an application with a universal dimmer and related buttons) .

N.B.: The universal dimmers must be configured as White (art. 20549-19549-14549 or 20137-19137-14137 + 20529-19529-14529).

After configuring the dimmer to set the control set point, proceed as follows:

- activate the brightness adjustment control;
- activate the dimmer adjustment control;
- make an adjustment and wait a minute; following the environment light change the dimmer should change its output.

N.B.:

- Select **Humidity xx433** to connect only the Vimar humidity sensor 20433-19433-14433.
- Select **Generic** to connect any other voltage or current sensor.
- Select **Generic Use** only to read the input values.

9.3.4 Configuration of thermostat 02951

The thermostat consists of **1 Main functional unit** and **4 identical Output functional units** that are configured in the applications in which we wish also to include the actuator to control the climate control source (radiators, fan coils, etc.).

To enter the thermostat configuration mode you need to:

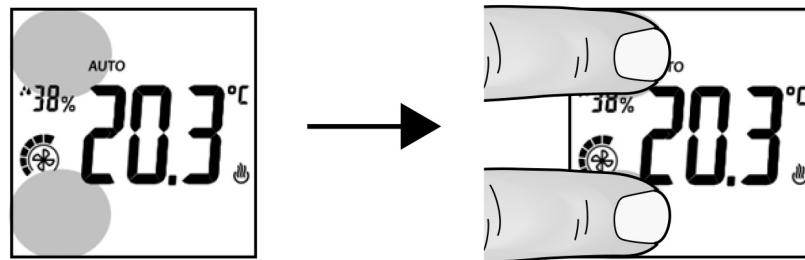

- Press (quickly) the areas of the display shown in the figure simultaneously:



The backlighting becomes red and the display shows **CnF** (configuration).

9.3.5 Configuration of thermostat 30471-02971

The thermostat consists of **1 Main functional unit (Thermostat)**, **4 Output functional units**, **4 Input functional units** and **1 ☆ key functional unit**. The Output functional should be configured in the applications in which you desire to include also the actuator to control the climate control source (radiators, fan coils, etc.).

For the thermostat to enter configuration mode, press the  and  keys simultaneously (quick press).

The circular ring becomes red and the display shows **CnF** (configuration).

9.3.6 Configuration of the temperature probe 30478-20538-19538-14538

The temperature probe consists of **1 Main functional unit** and **4 identical Output functional units** that are configured in the applications in which we desired also to include the actuator to control the climate control source (radiators, fan coils, etc.).

9.3.7 Configuration of the IR interface 20584.1-19584.1-14584.1

The device consists of 2 identical functional units. During configuration, when pressing the device push button, it is automatically paired with the functional unit that is still free. For example, the 2 units can be paired respectively with a heating output functional unit and a thermostat cooling output unit.

The device can be configured in the Climate control menu **only if a thermostat Output functional unit** has already been configured in the application; if this is not the case an error message will be displayed.

The IR interface can be controlled from a button or from the device with 3 analogue signal inputs (art. 01467).

If there is a 3-input device 01467 and a button, the latter will be paired with the 3-input device 01467 (to enable or disable the exceeding threshold function).

Temperature control

The IR interface is capable of saving the button of an infrared remote control and of replicating its operation following a By-me control. When the interface is active the LED, if enabled, is permanently lit green; it flashes briefly each time a By-me control is received that involves sending IR controls.

It is possible to acquire up to 12 actions (action = repetition of an infrared remote control button) that are named as follows in the App:

- Action 1 (A1)
- Action 2 (A2)
- Action 3 (A3)
- Action 4 (A4)
- Action 5 (A5)
- Action 6 (A6)
- Action 7 (A7)
- Action 8 (A8)
- Action 9 (A9)
- Action 10 (A10)
- Action 11 (A11)
- Action 12 (A12)

Operation is ensured when, starting with the actions, the following controls thus named are coded:

Control	Meaning
IR ON	Power-on control
IR OFF	Power-down control
IR V1	Speed 1 control
IR V2	Speed 2 control
IR V3	Speed 3 control

Each control can be coded as the sequence of 1, 2, 3 or 4 actions and this corresponds to consecutively pressing up to 4 push buttons on the remote control of the controlled device.

Configuration

The IR interface 20584.1-19584.1-14584.1 is configured in two phases:

1. Registration button of a remote control (action)
2. Pair actions with the actual control.

Creation of an action and registering the key of a remote control

Follow the instructions displayed by the View Pro App.

Press the configuration push button of the interface 20584.1-19584.1-14584.1; the orange LED will be permanently lit.

Move the remote control near to the IR interface (to a distance of about 10 cm) and within 10 s, as in normal use, press the button you want to register.

Then select **Add**.

If acquisition is successful, the interface LED will turn off; the action will then be displayed in the list of configured actions (A1, A2, etc.).

If the acquisition is not successful (flashing quickly) carry out the following check:

- position the remote control towards the window of the IR interface at a distance of about 10 cm;
- check the condition of the batteries of the remote control and its operation;
- check that the infrared frequency of the audio device is between 30kHz and 60kHz.

As regards the remote control, you should save the buttons that are generally used for the ON, OFF, V1, V2 and V3 operations and in the table below note down the reference between the name of the memory used and the corresponding remote control button.

Action	Remote control button
Action 1	
Action 2	
Action 3	
Action 4	
Action 5	
Action 6	
Action 7	
Action 8	
Action 9	
Action 10	
Action 11	
Action 12	

Temperature control

Pair actions with the actual control.

Use this operation to create the controls pairing up to 4 already registered actions.

Select the control to pair (**ON**, **OFF**, etc.); 4 selection fields are then displayed (**Action 1**, **Action 2**, **Action 3** and **Action 4**), each one of which represents an action paired with the control.

The 4 fields will show dashes if there is no paired action.

It is now possible in each field to choose any of the registered actions; the fields are indexed from 1 to 4 that is the order in which the actions will be performed by the control.

Lastly touch **Set** that causes the data to be transferred to the IR device.

Example.

Action	Remote control button
Action 1	On
Action 2	OFF
Action 3	-
Action 4	-
Action 5	-
Action 6	Speed 2
Action 7	-
Action 8	-
Action 9	-
Action 10	-
Action 11	-
Action 12	-

Control	Action 1	Action 2	Action 3	Action 4
ON	Action 1	Action 6	None	None
OFF	Action 2	None	None	None
V1	None	None	None	None
V2	None	None	None	None
V3	None	None	None	None

In the example above note that the ON control is coded as the playback sequence of Actions 1 and 6 that correspond to pressing the On and Speed 2 buttons of a hypothetical remote control in sequence. The ON operation is then paired with the actions of the 2 buttons indicated alternated by the **Inter-time** parameter that causes switching on the device, selecting the speed as required for the ON control.

Temperature control

9.4 Device parameters.

Device parameters can be set and/or modified in order to customise their functions and adapt the system to the various installation requirements.

• HVAC CONTROLLER FOR HEATING SYSTEMS 01465

Main and Circulation Pump Functional Unit

- **Max. delivery temp.:** Parameter for setting the maximum delivery temperature in heating.
It can also be used as a threshold for limiting the screed temperature when the delivery supplies an underfloor heating system; the screed temperature measured through the auxiliary probe is not used since, because of the thermal dispersion, it will be less than the delivery temperature.
- **Min. delivery temp.:** Parameter for setting the maximum delivery temperature in Air Conditioning.
- **Minimum voltage/current adjustment value on the proportional output:**
 - Minimum current adjustment 0.0 mA.
 - Minimum voltage adjustment 0.0 V.
- **Maximum voltage/current adjustment value on the proportional output:**
 - Maximum current adjustment 20.4 mA.
 - Maximum voltage adjustment 10.2 V.
- **Adjustment polarity:** Is the direction in which the proportional output control is made.
 - Select "Normal" and, as the % value increases, the valve opening will increase.
For example: 0%=Closed, 100%=Open
 - Select "Reversed" and, as the % value increases, the valve opening will decrease.
For example: 0%=Open, 100%=Closed"
- **Valve in OFF position:** Parameter that, if the circulation pump is turned off, is used to set whether the mixing valve has to be closed (0%) or placed in a desired position (1..100%); in any case, the control algorithm is interrupted.

The HVAC controller, after an outputs inactivity time equal to 12h, starting from 2h later makes a switching sequence to prevent the seizure of the connected load (either pump or valve); more precisely uses the following three parameters:

- **Pump anti-seize:** Pump switching On/Off for a fixed time; this time value affects the PID algorithm whether the valve is ON/OFF or proportional.
- **Open/Close valve anti-seize:** Open/closed switching for a fixed time.
- **Proportional valve anti-seize:** 0-100% switching for a fixed time.
- **Valve opening time:** It is the time taken for the valve to perform a closing/opening cycle (Off/On). It is used for the calibration of the open/close valve.
- **Valve closing time:** It is the time taken for the valve to perform an opening/closing cycle (On/Off). It is used for the calibration of the open/close valve.
- **Delivery probe type:** It allows the operator to set the type of delivery probe installed in the system.
- **Value transmission:** Indicates how to force the transmission of a temperature message.
- **Transmission interval:** If the Value transmission is set on **time-based** the parameter indicates how often the value measured should be sent. If the Value transmission is set on **time-based change** the parameter indicates the minimum time to validate the change and activate the transmission.
- **Air conditioning correction factor:** K coefficient (fixed) for the calculation of the delivery temperature in Air conditioning mode.
The coefficient is used to obtain the delivery temperature value through the relation:

$$\text{Delivery T} = \text{Set point} + K \times (\text{Set point} - \text{External T})$$
Example of underfloor or fan coil system
 For a room temperature of 23°C with external limit temperature of 35°C; to obtain a delivery temperature of 14°C, the air conditioning correction factor (K) must be equal to 0.8.
- **Heating correction factor:** K coefficient (fixed) for the calculation of the delivery temperature in Heating mode.
The coefficient is used in the following formula to obtain the delivery temperature value:

$$\text{Delivery T} = \text{Set point} + K \times (\text{Set point} - \text{External T})$$
Example of underfloor system
 For a room temperature of 20°C with external limit temperature of 0°C; to obtain a delivery temperature 35°C, the air conditioning correction factor (K) must be equal 0.8.
- **Example of radiator or fan coil system**
 For a room temperature of 20°C with external limit temperature of 0°C; to obtain a delivery temperature 60°C, the air conditioning correction factor (K) must be equal 2.0.
- **Band (P):** Parameter used by the PID algorithm to calculate the coeff. $K_p = 100/B_p$.
Corresponds to the breadth of proportional adjustment range: starting from the set temperature, this value represents the temperature range in which the system power goes from 0% to 100%.
For example: with the temperature, set to 50.0°C and Band (P) =4.0°C, the HVAC controller opens the mixer valve at 100% when the **delivery T.** is ≤ 46.0 °C; as this temperature increases, the valve opening is consequently lowered down to 0% when the delivery temperature reaches 50°C. The value must be set consistently with the thermal capacity of the source to be controlled; in general, it is recommended to use small values for high thermal capacity (therefore longer reaction time) and vice-versa.
- **Time (I):** Parameter used by the PID algorithm to calculate the coeff. $K_i = K_p/T_i$.
Corresponds to the time after which, when equal to the deviation from the setpoint (error), the additional component generates a contribution equal to that generated by the proportional component. The integral contribution is used to reduce the error on full operation if thermal energy is lost in the environment controlled, as this contribution increases according to the time during which the setpoint is not reached. If this value is not set perfectly, it can cause transients with oscillations around the setpoint or it may take longer to reach the setpoint.

Temperature control

- **Time (D):** Parameter used by the PID algorithm to calculate the coeff. $K_d = K_p * T_d$.

Corresponds to the time only the proportional action would take to generate a control signal equal to that produced by the derivative action. The derivative contribution opposes the system variations and has no role in eliminating the error but is used to stabilise the control operations, particularly in systems that are characterised by sudden variations. The derivative contribution must be enabled with care, particularly in systems with long dead times, as this could make the control chain unstable; generally the most appropriate algorithm in these cases corresponds to type PI (proportional-integral).

N.B.:

- 1) The delivery temperature sending is automatic and takes place at every change of 0.1°C.
- 2) The execution time of the PID algorithm is derived from the minimum value of the two "Valve opening time" and "Valve closing time" parameters and is valid for both the open/close valve and the proportional valve.

External Temperature and Auxiliary Temperature functional unit

- **Probe type:** It allows the operator to set the type of temperature probe installed in the system.
- **Value transmission:** Indicates how to force the transmission of a temperature message.
- **Transmission interval:** If the Value transmission is set on **time-based** the parameter indicates how often the value measured should be sent. If the Value transmission is set on **time-based change** the parameter indicates the minimum time to validate the change and activate the transmission.

Humidity Functional Unit

- **Probe calibration:** It is the humidity measurement calibration value; this value is added to or subtracted from humidity measured by the sensor of the same group to obtain the desired value.

Types of alarm and HVAC controller actions

- **Delivery probe failure alarm:** The controller shuts down (the pump is turned off and the mixing valve closed), the green status LED flashes and the alarm is indicated by the bus.
- **External probe failure alarm:** The HVAC controller forces the temperature measured at 30°C in air conditioning and 0°C in heating, the green status LED flashes and the alarm is indicated by the bus.
- **Auxiliary probe failure alarm:** In this case, the green device status LED flashes and the alarm is indicated by the bus. There is no adjustment block.
- **OUT3 proportional output overload alarm:** In this case the proportional output is forced to 0 V/mA, the output (OUT3) green status LED flashes and the alarm is indicated by the bus; there is no adjustment block. Once the cause that generated the alarm (for example an overcurrent) has been resolved, the output is automatically restored.
- **Block alarm:** The auxiliary contact input is opened or closed depending on the polarity set (NO or NC). If an alarm occurs the HVAC controller shutdown is started and therefore the pump turns off and the valve closes; once the alarm has been resolved, the controller resumes normal operation.

• PROPORTIONAL ANALOGUE 4-OUTPUT ACTUATOR 01466.1

- **Control polarity:** Represents the direction of the output analogue signal with which the valve is controlled (available only for temperature control applications).
Select "**Normal**" and, as the % value increases, the valve opening will increase.
For example: 0%=Closed, 100%=Open
Select "**Reversed**" and, as the % value increases, the valve opening will decrease.
For example: 0%=Open, 100%=Closed
- **Minimum value:** Minimum voltage/current adjustment value of the output channel:
- Minimum current adjustment 0.0 mA.
- Minimum voltage adjustment 0.0 V.
- **Maximum value:** Maximum voltage/current adjustment value of the output channel:
- Maximum current adjustment 20.4 mA.
- Maximum voltage adjustment 10.2 V.
- **Dimming speed:** Adjustment speed of the device analogue output.
Available only for Automation applications with "**Button control**"; used to set the adjustment speed i.e. the variation speed of the analogue output signal.
- **OFF value:** Output value in Off status.
Available only for applications with "**Button control**"; the parameter specifies the value in V-mA that the output channel must have when it receives an OFF control. The settable values are the following:
- if OFF, the output goes to the "minimum value".
- if OFF, the output goes to the zero value.
Example: If the control is used with a button with a dimmer function, it is possible to choose which value the proportional output assumes when the actuator receives an Off control.

• DEVICE WITH 3 ANALOGUE SIGNAL INPUTS 01467

The device consists of 3 functional units with which the respective parameters are paired.

Functional unit: input 0-10 V or 4-20 mA

- **Control threshold:** The parameter is used to modify the setpoint value.
- **Hysteresis:** The parameter is used to modify the adjustment hysteresis value.
- **Minimum value:** Minimum value of the input signal (example: in a 1-10 V sensor the paired value when the input read is equal to 1 V).
- **Maximum value:** Maximum value of the input signal (example: in a 1-10 V sensor the paired value when the input read is equal to 10 V).

Temperature control

- **Enable on start-up:** Defines the behaviour of the control on start-up:
 - control enabled;
 - control disabled;
 - analogue control at the last variation before power-down.
- **Control polarity:** Used to invert the output control behaviour.
 - Select **Value transmission** to set the following parameters:
 - ➔ **Value transmission:** Indicates how to force the transmission of a message.
 - ➔ **Transmission threshold:** Indicates the difference between 2 values read to generate a message transmission.
 - ➔ **Transmission interval:** Indicates the difference in time between 2 values read to generate a message transmission.
 - Select **Percentage transmission**, which only applies in the case of a device configured as “**Extension**”, to set the following parameters:
 - ➔ **Value transmission:** Indicates how to force the transmission of a message.
 - ➔ **Transmission threshold:** Indicates the difference between 2 values read to generate a message transmission.
 - ➔ **Transmission interval:** Indicates the difference in time between 2 values read to generate a message transmission.

N.B.:

The **Value transmission** and **Percentage transmission** parameters both transmit the value measured by the sensor; the former is the actual measurement expressed with 2 bytes while the latter is the percentage measurement of the value between MIN and MAX expressed with 1 byte.

Example 1: If you set min = 0 and max = 10V with the sensor that measures 5V at the output you will have a transmission value of 5V or a transmission percentage of 50%.

Example 2: If you set min = 0 and max 10V with the sensor that measures 10V at the output you will have a transmission value of 10V or a transmission percentage of 100%.

Functional unit: input for NTC temperature sensor

- **Value transmission:** Indicates how to force the transmission of a temperature message.
- **Transmission threshold:** Indicates the difference between 2 values read to generate a temperature message transmission.
- **Transmission interval:** Indicates the difference in time between 2 values read to generate a temperature message transmission.

Functional unit: input for Brightness dimmer sensor

- **Hysteresis:** The parameter is used to modify the adjustment hysteresis value.

• THERMOSTAT 02951

The thermostat consists of 2 functional units with which the respective parameters are paired.

Thermostat functional unit

- **Screed threshold:** Temperature value above which the screed limitation cuts in.
When this limitation is active, the thermostat will close its valve if the temperature measured by the Probe 2 (underfloor heating screed) exceeds the set threshold.
Caution: This is an extra action (and not for safety) that is added to the protection performed by the thermostatic valve prescribed by system regulations.
- **Probe 2:** Sets the use of probe 2 (which is a possible external probe which can be connected to the device); the settable values are the following:
 - Not present = Probe 2 not present.
 - Temperature control (exclusive) = for temperature control, in place of Probe 1.
 - Temperature control (combined) = for temperature control, used as an average with Probe 1 (large rooms).
 - Screen Limit. = for screed limitation.
 - Display = display only (e.g: temperature in another room).
- **Neutral zone range:** Sets the range of the Neutral Zone centred on the related setpoint
In the **Neutral Zone** adjustment mode, the thermostat automatically switches between heating and air conditioning according to the set set point, the temperature measured and considering any neutral zone around the set point defined by the **Neutral Zone Range** parameter (set from 1°C to 5°C in 1°C steps).
For example, if the set point is set to 20°C and the neutral zone range is 2°C, the thermostat will switch the heating on if the temperature falls below 19°C (set point – neutral zone range/2) and will switch on the air conditioning if the temperature rises above 21°C (set point + neutral zone range/2). In this way a band of 2°C around which the thermostat neither heats or cools is defined (thus the name neutral zone).
Caution:
 - The “neutral zone” adjustment can of course be used only on 4-pipe systems (which can both heat and cool at the same time).
 - In the neutral zone adjustment mode, the thermostat only allows Manual and Off operating modes.
- **Operating limitations:** Defines the operating mode limitation, the following values can be set:
 - Limit.1 = auto/manual/off.
 - Limit.2 = manual/off.
 - Limit.3 = auto/off.
 Both setpoint operating or adjustment limitations are useful in applications such as guest rooms, offices, shops and tertiary applications generally.
- **Setpoint adj. limit.:** Defines the setpoint adjustment range limitation, the following values can be set:
 - No limitation = the setpoint can be adjusted across all the available range.
 - Range 0 = the current setpoint can be modified by maximum +/- 0.5°C of the setpoint value saved in the memory.
 - Range 1 = as above but +/- 1°C.
 - Range 2 = as above but +/- 2°C.
 - Range 3 = as above but +/- 3°C.
 - Range 4 = as above but +/- 4°C.
 - Range 5 = as above but +/- 5°C.

Temperature control

■ **View:** Defines what to view in the main screen; the following values can be set:

- Room temp. = room temperature (normal)
- Current setpoint = set point temperature
- Current setpoint delta.

Select "current setpoint delta":

- in the event of active setpoint adjustment limitations, the display shows the current setpoint delta compared to that locked in the limitation.

Example: **Setpoint adj. limit.** → **Range 2**, the display will show the values from -2°C to +2°C

- if there are no setpoint adjustment limitations, the display shows the setpoint value.

The "current setpoint delta" displayed is therefore used mainly in combination with **Setpoint adj. limit.**

■ **Humidity view:** Defines the viewing of the humidity value in the thermostat display.

Caution: To obtain this view, you must configure the functional unit input 0-10 V of device 01467 connected to the humidity probe in the same group as the thermostat.

■ **Probe 1 calibration:** Static calibration value of the internal probe (probe 1). In fact this is an offset to which the temperature value read by the probe must be summed.

■ **Probe 2 calibration:** Static calibration value of the internal probe (probe 2). In fact this is an offset to which the temperature value read by the probe must be summed.

The **Probe 1 calibration** and **Probe 2 calibration** parameters are useful in all cases where there is an error with respect to a reference value (installation in a position that alters the correct reading, such as, for instance, a north-facing wall, proximity to the hot or cold water piping) but also to align two thermostats together, to align to a thermometer measurement, etc.

■ Select **Temperature transmission** to set the following parameters:

- ➔ **Value transmission:** Indicates how to force the transmission of a temperature message.
- ➔ **Transmission interval:** Indicates the difference in time between 2 values read to generate a temperature message transmission.

Use **Temperature trans.** to set the period of updating the temperature value on the supervisor devices (touch screens, etc.).

■ Select **Window** to set the following parameters:

- ➔ **Reaction time:** Sets the reaction time if a window warning is received; in fact, it indicates after how much time the thermostat block should come on if a window is open.

Example:

When the window is closed the heating/air conditioning is on; if the window is opened the heating/air conditioning stays on for the time set in the **Reaction time**. If within that time interval the window is closed, the heating/air conditioning remains on.

- ➔ **Reactivation time:** Sets the reactivation time if a window warning is received; in fact, it indicates after how much time the thermostat block should be removed due to an open window.

Example:

When the window is closed the heating/air conditioning is on; if the window is opened the heating/air conditioning turns off and remains so for the time set in the **Reaction time**. At the end of the time interval the heating/air conditioning comes back on whether or not the window has been closed.

Output functional unit

■ **Control alg.:** Select the algorithm to use for the temperature control of the related output.

- ➔ **On/Off:** This is the traditional "threshold" control so that, on exceeding the set temperature increased by the temperature differential (vice versa for air conditioning), the heating is switched off to then be turned back on when the room temperature drops below the set temperature.
- ➔ **PID:** This is an evolved algorithm that is able to keep the temperature in the environment more stable, increasing comfort; this algorithm switches the system on and off appropriately so there will be a gradual increase or decrease in the thermal (or refrigerating) power of the system itself. To fully exploit the performances, it must be appropriately calibrated according to the type of environment or heating system, by setting the related parameters.

■ **Hysteresis:** Sets the hysteresis value to be used in the case of an on/off algorithm (can be set from 0.1°C to 1°C in 0.1°C steps)

■ **PWM time:** Sets the length of a PWM cycle in the case of a PID algorithm for controlling on/off valves.

It therefore corresponds to the **time** in which a cycle of adjustment is completed; the shorter this time, the better the adjustment but the temperature control system is under greater stress. This parameter setting is thus the result of a compromise between the accuracy of the dimmer and the load on the system; in general, the rule is that T_b can be that much higher (and therefore put fewer demands on the system), the slower the system or the larger the environment to regulate.

Caution: The value must be much greater than the on and off times of the valves

■ **Band (P):** Parameter used by the PID algorithm to calculate the coeff. $K_p = 100/B_p$.

Corresponds to the breadth of proportional adjustment range: starting from the set temperature, this value represents the temperature range in which the system power goes from 0% to 100%.

For example: with the (heating) temperature, set to 20.0°C and Band (P) = 4.0°C, the thermostat runs the heating system at 100% when **room T.** is ≤ 16.0 °C; as this temperature increases, the system power is consequently lowered down to 0% when the room temperature reaches 20°C. The value must be set consistently with the thermal capacity of the environment controlled; in general, it is recommended to use small values for environments with a good level of thermal insulation and vice-versa.

■ **Time (I):** Parameter used by the PID algorithm to calculate the coeff. $K_i = K_p/T_i$.

Corresponds to the time after which, when equal to the deviation from the setpoint (error), the additional component generates a contribution equal to that generated by the proportional component. The integral contribution is used to reduce the error on full operation if thermal energy is lost in the environment controlled, as this contribution increases according to the time during which the setpoint is not reached. If this value is not set perfectly, it can cause transients with oscillations around the setpoint or it may take longer to reach the setpoint.

Temperature control

- **Time (D):** Parameter used by the PID algorithm to calculate the coeff. $K_d = K_p * T_d$.
Corresponds to the time only the proportional action would take to generate a control signal equal to that produced by the derivative action. The derivative contribution opposes the system variations and has no role in eliminating the error but is used to stabilise the control operations, particularly in systems that are characterised by sudden variations. The derivative contribution must be enabled with care, particularly in systems with long dead times, as this could make the control chain unstable; generally the most appropriate algorithm in these cases corresponds to type PI (proportional-integral).
- Select **Fan coil** to set the following parameters:
 - ➔ **Speed control:** It is possible to select two different control modes:
 - Interlock: the thermostat sends a control message exclusively at a single speed: V1, V2 or V3
 - Step-step: the thermostat sends a message cumulatively: V1, V1+V2, V1+V2+V3
 - ➔ **Start delay:** It sets the delay time of the fan start.
This parameter is used only during the operating or adjustment mode change while it is not used during temperature control (for example if the thermostat switches off the output and then switches it back on)
 - ➔ **Speed band:** It defines the thermal delta to run the fan coil fan at maximum speed.
The speed scale (in the case of an on/off algorithm) is defined in correspondence to the difference between the room temperature and the current Setpoint.

In addition to those described previously, select the zone to which the thermostat is paired to set the following parameters:

- **Aux. heat threshold:** Difference from the setpoint for starting the boost function in heating mode; the function is switched off when the required temperature (setpoint) is reached, increased by the temperature differential.
- **Aux. air-con. threshold:** Difference from the setpoint for starting the boost function in air conditioning mode; the function is switched off when the required temperature (setpoint) is reached, decreased by the temperature differential.
- **Ecometer:** Enables the ecometer function. If the ecometer is disabled, the backlighting is fixed and turns to the colour set in the **Backlight Colour** parameter; otherwise the backlighting varies according to the set setpoint.
- **Backlight Colour:** Sets the backlighting RGB colour coordinates.
- **Temperature unit:** Sets the unit of measure used to view the temperature on the display
- **Keypad lock:** Enables the keypad lock (disables the keys).
- **Sounds:** Enabling of sounds paired to buttons when pressed.

• THERMOSTAT 30471-02971

The thermostat consists of 7 functional units with which the respective parameters are paired.

There are also some parameters designed to make those settings linked closely to the device, i.e. display brightness level, LED colour, etc.

Device

- **Display brightness level OFF :** Sets the brightness level when the thermostat display is on standby.
- **Enable monochrome mode:** Enables the mode to assign an unequivocal colour to all LEDs.
- **Monochrome mode colour:** Sets the RGB colour of all LEDs (except the one for the ☆ key when pressed).
- **Behaviour of the ☆ key when it is not configured:** Defines the function of the ☆ key in the event that it is not configured, namely:
 - No action.
 - Probe 2 temperature display if pressed
 - Toggle selection of the Summer/Winter function in the thermostat; this function is signalled by the colour of the ON/OFF LED (default: orange for Winter and blue for Summer).
- **Colour of key ☆ :** Sets the RGB colour of the LED of key ☆ when pressed.
- **Probe 2 calibration:** Static calibration value of the internal probe (Probe 2). In fact this is an offset to which the temperature value ready by the probe must be summed. This parameter is useful in all cases where there is an error with respect to a reference value (installation in a position that alters the correct reading, such as, for instance, a north-facing wall, proximity to the hot or cold water piping) but also to align two thermostats together, to align to a thermometer measurement, etc.

Thermostat functional unit

- **Operating mode ON:** Defines the type of operation (Automatic, Manual, Reduction) associating it with the ON control of the thermostat key.
- **Operating mode OFF:** Defines the type of operation (Absence, Protection, Off) associating it with the OFF control of the thermostat key.
- **Enable boost on auxiliary heating output:** Enables the boot function in heating and indicates whether the output marked as auxiliary must be used for the boost (+ mid season) or only for the mid season.
- **Enable boost on auxiliary air conditioning output:** Enables the boot function in air conditioning and indicates whether the output marked as auxiliary must be used for the boost (+ mid season) or only for the mid season.
- **Screed threshold:** Temperature value above which the screed limitation cuts in.
When this limitation is active, the thermostat will close its valve if the temperature measured by the Probe 2 (underfloor heating screed) exceeds the set threshold.
Caution: This is an extra action (and not for safety) that is added to the protection performed by the thermostatic valve prescribed by system regulations.
- **Probe 2:** Sets the use of probe 2 (which is a possible external probe which can be connected to the device); the settable values are the following:
 - Not present = Probe 2 not present.
 - Temperature control (exclusive) = for temperature control, in place of Probe 1.
 - Temperature control (combined) = for temperature control, used as an average with Probe 1 (large rooms).
 - Screen Limit. = for screed limitation.
 - Display = display only (e.g. temperature in another room).

Temperature control

- **Neutral zone range:** Sets the range of the Neutral Zone centred on the related setpoint

In the **Neutral Zone** adjustment mode, the thermostat automatically switches between heating and air conditioning according to the set set point, the temperature measured and considering any neutral zone around the set point defined by the **Neutral Zone Range** parameter (set from 1°C to 5°C in 1°C steps).

For example, if the set point is set to 20°C and the neutral zone range is 2°C, the thermostat will switch the heating on if the temperature falls below 19°C (set point – neutral zone range/2) and will switch on the air conditioning if the temperature rises above 21°C (set point + neutral zone range/2). In this way a band of 2°C around which the thermostat neither heats or cools is defined (thus the name neutral zone).

Caution:

- The "neutral zone" adjustment can of course be used only on 4-pipe systems (which can both heat and cool at the same time).
- In the neutral zone adjustment mode, the thermostat only allows Manual and Off operating modes.

- **Heating Setpoint adj. limit:** Defines the setpoint adjustment range limitation in heating mode; the following values can be set:

- No limitation = the setpoint can be adjusted across all the available range.
- Range 0 = the current setpoint can be modified by maximum +/- 0.5°C of the setpoint value saved in the memory.
- Range 1 = as above but +/- 1°C.
- Range 2 = as above but +/- 2°C.
- Range 3 = as above but +/- 3°C.
- Range 4 = as above but +/- 4°C.
- Range 5 = as above but +/- 5°C.

- **Air conditioning Setpoint adj. limit:** Defines the setpoint adjustment range limitation in air conditioning mode; the following values can be set:

- No limitation = the setpoint can be adjusted across all the available range.
- Range 0 = the current setpoint can be modified by maximum +/- 0.5°C of the setpoint value saved in the memory.
- Range 1 = as above but +/- 1°C.
- Range 2 = as above but +/- 2°C.
- Range 3 = as above but +/- 3°C.
- Range 4 = as above but +/- 4°C.
- Range 5 = as above but +/- 5°C.

- **View:** Defines what to view in the main screen; the following values can be set:

- Room temp. = room temperature (normal)
- Current setpoint = set point temperature
- Current setpoint delta.

Select "current setpoint delta":

- in the event of active setpoint adjustment limitations, the display shows the current setpoint delta compared to that locked in the limitation.

Example: **Setpoint adj. limit.** ➔ **Range 2**, the display will show the values from -2°C to +2°C

- if there are no setpoint adjustment limitations, the display shows the setpoint value.

The "current setpoint delta" displayed is therefore used mainly in combination with **Setpoint adj. limit.**

- **Probe 1 calibration:** Static calibration value of the internal probe (probe 1). In fact this is an offset to which the temperature value read by the probe must be summed.

- **Air conditioning Offset Calibration:** Offset to which the value of the temperature read by the Probe in Air conditioning must be summed. For probe 2 the calibration value is already applied in the functional unit of origin.

- **Heating Offset Calibration:** Offset to which the value of the temperature read by the Probe in Heating must be summed. For probe 2 the calibration value is already applied in the functional unit of origin.

- **Fan forcing:** Designed to control the fans irrespective of the valve state.

- **Restart after shutdown:** Defines the behaviour of the thermostat following a restart after shutdown.

- **Value transmission:** Indicates how to force the transmission of a temperature message.

- **Transmission interval:** Indicates the difference in time between 2 values read to generate a temperature message transmission. Designed to set the period of updating the temperature value on the supervisor devices (touch screens, etc.).

- **Aux. heat threshold:** Difference from the setpoint for starting the boost function in heating mode; the function is switched off when the required temperature (setpoint) is reached, increased by the temperature differential.

- **Aux. air-con. threshold:** Difference from the setpoint for starting the boost function in air conditioning mode; the function is switched off when the required temperature (setpoint) is reached, decreased by the temperature differential.

- **Temperature unit:** Sets the unit of measure used to view the temperature on the display

- **Keypad lock:** Enables the keypad lock (disables the keys).

Output functional unit

- **Control algorithm:** Defines the algorithm for the room temperature to match that of the setpoint set; the options are the following:

- On/Off = This is the traditional "threshold" control so that, on exceeding the set temperature increased by the temperature differential (vice versa for air conditioning), the heating is switched off to then be turned back on when the room temperature drops below the set temperature.

- PID = This is an evolved algorithm that is able to keep the temperature in the environment more stable, increasing comfort; this algorithm switches the system on and off appropriately so there will be a gradual increase or decrease in the thermal (or refrigerating) power of the system itself. To fully exploit the performances, it must be appropriately calibrated according to the type of environment or heating system, by setting the related parameters.

- **Hysteresis:** Sets the hysteresis value to be used in the case of an on/off algorithm (can be set from 0.1°C to 1°C in 0.1°C steps)

- **PWM time:** Sets the length of a PWM cycle in the case of a PID algorithm for controlling on/off valves.

Temperature control

It therefore corresponds to the time in which a cycle of adjustment is completed; the shorter this time, the better the adjustment but the temperature control system is under greater stress. This parameter setting is thus the result of a compromise between the accuracy of the dimmer and the load on the system; in general, the rule is that T_b can be that much higher (and therefore put fewer demands on the system), the slower the system or the larger the environment to regulate.

Caution: The value must be much greater than the on and off times of the valves

- **Band (P):** Parameter used by the PID algorithm to calculate the coeff. $K_p = 100/B_p$.
Corresponds to the breadth of proportional adjustment range: starting from the set temperature, this value represents the temperature range in which the system power goes from 0% to 100%.
For example: with the (heating) temperature, set to 20.0°C and Band (P) =4.0°C, the thermostat runs the heating system at 100% when **room T.** is ≤ 16.0 °C; as this temperature increases, the system power is consequently lowered down to 0% when the room temperature reaches 20°C. The value must be set consistently with the thermal capacity of the environment controlled; in general, it is recommended to use small values for environments with a good level of thermal insulation and vice-versa.
- **Time (I):** Parameter used by the PID algorithm to calculate the coeff. $K_i = K_p/T_i$.
Corresponds to the time after which, when equal to the deviation from the setpoint (error), the additional component generates a contribution equal to that generated by the proportional component. The integral contribution is used to reduce the error on full operation if thermal energy is lost in the environment controlled, as this contribution increases according to the time during which the setpoint is not reached. If this value is not set perfectly, it can cause transients with oscillations around the setpoint or it may take longer to reach the setpoint.
- **Time (D):** Parameter used by the PID algorithm to calculate the coeff. $K_d = K_p * T_d$.
Corresponds to the time only the proportional action would take to generate a control signal equal to that produced by the derivative action. The derivative contribution opposes the system variations and has no role in eliminating the error but is used to stabilise the control operations, particularly in systems that are characterised by sudden variations. The derivative contribution must be enabled with care, particularly in systems with long dead times, as this could make the control chain unstable; generally the most appropriate algorithm in these cases corresponds to type PI (proportional-integral).
- **Speed control:** It is possible to select two different control modes:
 - Interlock: the thermostat sends a control message exclusively at a single speed: V1, V2 or V3
 - Step-step: the thermostat sends a message cumulatively: V1, V1+V2, V1+V2+V3
- **Start delay:** It sets the delay time of the fan start.
This parameter is used only during the operating or adjustment mode change while it is not used during temperature control (for example if the thermostat switches off the output and then switches it back on)
- **Speed band:** It defines the thermal delta to run the fan coil fan at maximum speed.
The speed scale (in the case of an on/off algorithm) is defined in correspondence to the difference between the room temperature and the current Setpoint.

Input functional unit Probe 2 thermostat

- **Value transmission:** Indicates how to force the transmission of a temperature message.
- **Transmission interval:** Indicates the difference in time between 2 values read to generate a temperature message transmission. Designed to set the period of updating the temperature value on the supervisor devices (touch screens, etc.).

Input functional unit Contact thermostat

- **Reaction time:** Depending on how the "Operation" parameter has been set with reference to the window or the boiler shutdown, it sets the reaction time in the event that a signal arrives; in actual fact, it indicates after how long the thermostat shutdown is activated following the signalling.
Example:
When the window is closed the heating/air conditioning is on; if the window is opened the heating/air conditioning stays on for the time set in the **Reaction time**. If within that time interval the window is closed, the heating/air conditioning remains on.
- **Reactivation time:** Depending on how the "Operation" parameter has been set with reference to the window or boiler shutdown, it sets the reactivation time if a window warning is received; in fact, it indicates after how much time the thermostat shutdown should be removed following the signalling.
Example:
When the window is closed the heating/air conditioning is on; if the window is opened the heating/air conditioning turns off and remains so for the time set in the **Reaction time**. At the end of the time interval the heating/air conditioning comes back on whether or not the window has been closed.
- **Operation:** Defines what to view in the main screen; the following values can be set:
 - Window open
 - Shutdown alarm
- **Control input report:** Defines the behaviour of the alarm upon closing or opening of the input.

Input functional unit window contact from BUS

- **Reaction time:** Sets the reaction time if a window warning is received; in fact, it indicates after how much time the thermostat block should come on if a window is open.
Example:
When the window is closed the heating/air conditioning is on; if the window is opened the heating/air conditioning stays on for the time set in the **Reaction time**. If within that time interval the window is closed, the heating/air conditioning remains on.
- **Reactivation time:** Sets the reactivation time if a window warning is received; in fact, it indicates after how much time the thermostat block should be removed due to an open window.
Example:
When the window is closed the heating/air conditioning is on; if the window is opened the heating/air conditioning turns off and remains so for the time set in the **Reaction time**. At the end of the time interval the heating/air conditioning comes back on whether or not the window has been closed.
- **Control input report:** Defines the behaviour of the alarm upon closing or opening of the input.

Temperature control

Input functional unit Block contact from BUS

- **Reaction time:** Sets the reaction time if an open contact signal is received; in fact, it indicates after how much time the thermostat shutdown should come on if a boiler shuts down.

Example:

When the contact is closed, the boiler is working properly; if the contact opens the thermostat stays on for an amount of time equal to **Reaction time**. If within that time interval the boiler resumes working, the thermostat remains on.

- **Reactivation time:** Sets the reactivation time if an open contact signal is received; in fact, it indicates after how much time the thermostat shutdown should be removed if a boiler shuts down.

Example:

When the contact is closed, the boiler is working properly; if the contact opens the thermostat is turned off and remains off for an amount of time equal to **Reactivation time**. At the end operation of the time interval the thermostat comes back on whether or not the boiler has resumed operation.

- **Control input report:** Defines the behaviour of the alarm upon closing or opening of the input.



key functional unit

- **Push button behaviour:** normal push button ON when the button is pressed, OFF when it is released, reversed push button OFF when pressed, ON when released, toggle on the rising edge, toggle on the falling edge, toggle on both edges, ON only ON when pressed, OFF only OFF when pressed.
Default value "Toggle on the rising edge".

• TEMPERATURE PROBE 30478-20538-19538-14538

The temperature probe consists of 2 functional units with which the respective parameters are paired.

Thermostat functional unit

- **Screed threshold:** Temperature value above which the screed limitation cuts in.

When this limitation is active, the temperature probe will close its valve if the temperature measured by the Probe 2 (underfloor heating screed) exceeds the set threshold.

Caution: This is an extra action (and not for safety) that is added to the protection performed by the thermostatic valve prescribed by system regulations.

- **Probe 2:** Sets the use of probe 2 (which is a possible external probe which can be connected to the device); the settable values are the following:

- Not present = Probe 2 not present.
- Temperature control (exclusive) = for temperature control, in place of Probe 1.
- Temperature control (combined) = for temperature control, used as an average with Probe 1 (large rooms).
- Screen Limit. = for screed limitation.
- Display = display only (e.g. temperature in another room).

- **Neutral zone range:** Sets the range of the Neutral Zone centred on the related setpoint

In the **Neutral Zone** adjustment mode, the thermostat automatically switches between heating and air conditioning according to the set set point, the temperature measured and considering any neutral zone around the set point defined by the **Neutral Zone Range** parameter (set from 1°C to 5°C in 1°C steps).

For example, if the set point is set to 20°C and the neutral zone range is 2°C, the thermostat will switch the heating on if the temperature falls below 19°C (set point - neutral zone range/2) and will switch on the air conditioning if the temperature rises above 21°C (set point + neutral zone range/2). In this way a band of 2°C around which the thermostat neither heats or cools is defined (thus the name neutral zone).

Caution:

- The "neutral zone" adjustment can of course be used only on 4-pipe systems (which can both heat and cool at the same time).
- In the neutral zone adjustment mode, the thermostat only allows Manual and Off operating modes.

- **Setpoint adj. limit.:** Defines the setpoint adjustment range limitation, the following values can be set:

- No limitation = the setpoint can be adjusted across all the available range
- Range 0 = the current setpoint can be modified by maximum +/- 0.5°C of the setpoint value saved in the memory
- Range 1 = as above but +/- 1°C:
- Range 2 = as above but +/- 2°C:
- Range 3 = as above but +/- 3°C:
- Range 4 = as above but +/- 4°C:
- Range 5 = as above but +/- 5°C:

- **Probe 1 calibration:** Static calibration value of the internal probe (probe 1). In fact this is an offset to which the temperature value read by the probe must be summed.

- **Probe 2 calibration:** Static calibration value of the internal probe (probe 2). In fact this is an offset to which the temperature value read by the probe must be summed.

The **Probe 1 calibration** and **Probe 2 calibration** parameters are useful in all cases where there is an error with respect to a reference value (installation in a position that alters the correct reading, such as, for instance, a north-facing wall, proximity to the hot or cold water piping) but also to align two thermostats together, to align to a thermometer measurement, etc.

- Select **Temperature transmission** to set the following parameters:

- **Value transmission:** Indicates how to force the transmission of a temperature message.
- **Transmission interval:** Indicates the difference in time between 2 values read to generate a temperature message transmission.

Use **Temperature trans.** to set the period of updating the temperature value on the supervisor devices (touch screens, etc.).

Temperature control

■ Select **Window** to set the following parameters:

- ➔ **Reaction time:** Sets the reaction time if a window warning is received; in fact, it indicates after how much time the thermostat block should come on if a window is open.

Example:

When the window is closed the heating/air conditioning is on; if the window is opened the heating/air conditioning stays on for the time set in the **Reaction time**. If within that time interval the window is closed, the heating/air conditioning remains on.

- ➔ **Reactivation time:** Sets the reactivation time if a window warning is received; in fact, it indicates after how much time the thermostat block should be removed due to an open window.

Example:

When the window is closed the heating/air conditioning is on; if the window is opened the heating/air conditioning turns off and remains so for the time set in the **Reaction time**. At the end of the time interval the heating/air conditioning comes back on whether or not the window has been closed.

Output functional unit

■ **Control alg.:** Select the algorithm to use for the temperature control of the related output.

- ➔ **On/Off:** This is the traditional "threshold" control so that, on exceeding the set temperature increased by the temperature differential (vice versa for air conditioning), the heating is switched off to then be turned back on when the room temperature drops below the set temperature.
- ➔ **PID:** This is an evolved algorithm that is able to keep the temperature in the environment more stable, increasing comfort; this algorithm switches the system on and off appropriately so there will be a gradual increase or decrease in the thermal (or refrigerating) power of the system itself. To fully exploit the performances, it must be appropriately calibrated according to the type of environment or heating system, by setting the related parameters.

■ **Hysteresis:** Sets the hysteresis value to be used in the case of an on/off algorithm (can be set from 0.1°C to 1°C in 0.1°C steps)

■ **PWM time:** Sets the length of a PWM cycle in the case of a PID algorithm for controlling on/off valves.

It therefore corresponds to the **time** in which a cycle of adjustment is completed; the shorter this time, the better the adjustment but the temperature control system is under greater stress. This parameter setting is thus the result of a compromise between the accuracy of the dimmer and the load on the system; in general, the rule is that T_b can be that much higher (and therefore put fewer demands on the system), the slower the system or the larger the environment to regulate.

Caution: The value must be much greater than the on and off times of the valves.

■ **Band (P):** Parameter used by the PID algorithm to calculate the coeff. $K_p = 100/B_p$.

Corresponds to the breadth of proportional adjustment range: starting from the set temperature, this value represents the temperature range in which the system power goes from 0% to 100%.

For example: with the (heating) temperature, set to 20.0°C and Band (P) = 4.0°C, the thermostat runs the heating system at 100% when **room T** is ≤ 16.0 °C; as this temperature increases, the system power is consequently lowered down to 0% when the room temperature reaches 20°C. The value must be set consistently with the thermal capacity of the environment controlled; in general, it is recommended to use small values for environments with a good level of thermal insulation and vice-versa.

■ **Time (I):** Parameter used by the PID algorithm to calculate the coeff. $K_i = K_p/T_i$.

Corresponds to the time after which, when equal to the deviation from the setpoint (error), the additional component generates a contribution equal to that generated by the proportional component. The integral contribution is used to reduce the error on full operation if thermal energy is lost in the environment controlled, as this contribution increases according to the time during which the setpoint is not reached. If this value is not set perfectly, it can cause transients with oscillations around the setpoint or it may take longer to reach the setpoint.

■ **Time (D):** Parameter used by the PID algorithm to calculate the coeff. $K_d = K_p * T_d$.

Corresponds to the time only the proportional action would take to generate a control signal equal to that produced by the derivative action. The derivative contribution opposes the system variations and has no role in eliminating the error but is used to stabilise the control operations, particularly in systems that are characterised by sudden variations. The derivative contribution must be enabled with care, particularly in systems with long dead times, as this could make the control chain unstable; generally the most appropriate algorithm in these cases corresponds to type PI (proportional-integral).

■ Select **Fan coil** to set the following parameters:

- ➔ **Speed control:** It is possible to select two different control modes:

- Interlock: the thermostat sends a control message exclusively at a single speed: V1, V2 or V3.
- Step-step: the thermostat sends a message cumulatively: V1, V1+V2, V1+V2+V3.

- ➔ **Start delay:** It sets the delay time of the fan start.

This parameter is used only during the operating or adjustment mode change while it is not used during temperature control (for example if the thermostat switches off the output and then switches it back on).

- ➔ **Speed band:** It defines the thermal delta to run the fan coil fan at maximum speed.

The speed scale (in the case of an on/off algorithm) is defined in correspondence to the difference between the room temperature and the current Setpoint.

In addition to those described above, the following parameters can be set in the zone menu to which the thermostat is paired:

■ **Aux. heat threshold:** Difference from the setpoint for starting the boost function in heating mode; the function is switched off when the required temperature (setpoint) is reached, increased by the temperature differential.

■ **Aux. air-con. threshold:** Difference from the setpoint for starting the boost function in air conditioning mode; the function is switched off when the required temperature (setpoint) is reached, decreased by the temperature differential.

• **IR INTERFACE 20584.1-19584.1-14584.1**

On the screen for the parameters of the IR interface there are also:

■ **LED Management:** (Default value 1=enabled). The LED signals IR transmission.

■ **Inter-time [sec]:** (Default value 1 s). Time in seconds that must pass between one repetition of an IR button and another one, that is between consecutive actions mapped within the same control.

Temperature control

9.4.1 Test procedure for the HVAC controller 01465

The test procedure, **to be carried out with the device not configured**, is used to check the connections and earthing of the HVAC controller during installation.

- Press the configuration push button for about 10 sec.
- When the LED from permanently red starts flashing in red/orange release the button.
- The test then start and throughout its duration, the configuration LED flashes green; the sequence of the functions checked is the following:

1. All outputs off and mixing valve output stopped.
2. Mixing valve opening activation.
3. Proportional output activation 100% (*).
4. Waiting (1 minute for the installer test).
5. Circulation pump activation.
6. Mixing valve closing activation.
7. Proportional output activation 0% (*).
8. Circulation pump closing (after 30 sec).
9. All outputs off and mixing valve output stopped.

(* Proportional output with default voltage.

The following figure shows the sequence of tests in relation to the duration of each individual function tested.

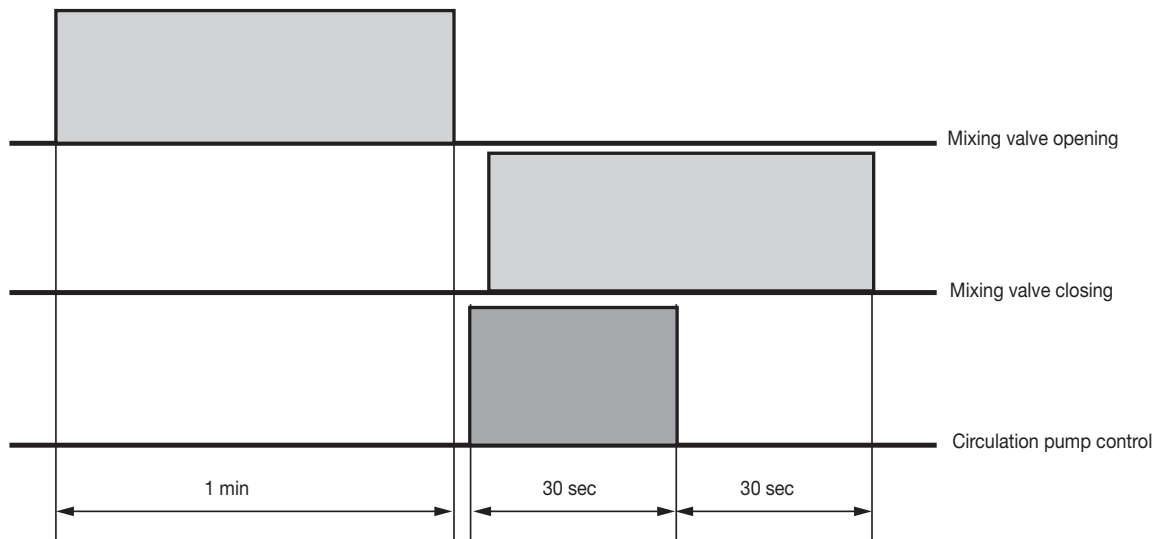

Eikon Tactil devices

10. EIKON TACTIL DEVICES

10.1. General characteristics

Eikon Tactil is designed for the use of touch controls, completely made of glass, to perform the functions normally carried out by the buttons and rocker buttons of the By-me Plus system. The device's RGB LEDs can also be rendered independent of the respective button and used as a signalling LED (actuator operation).

Marked by a high technological content, the devices should be completed with glass cover plates, which are available in four colour variants and distinguished by extreme sophistication teamed with extraordinary hard-wearing resistance.



To be activated, a gentle touch is sufficient, and the sophisticated technology transforms it into direct energy control; indeed, as soon as they are touched, a proximity sensor detects proximity to the device and activates the RGB LED backlighting integrated into the system. Moreover, once the push button is pressed, a dedicated acoustic signal confirms the button has been pressed.

Available in the 2- and 3-module versions, the devices are configured from the View Pro App, to perform on/off control functions, roller shutter control, light control, calling up scenarios and sound system controls; they are also fitted with bus terminals integrated into the device which facilitate wiring considerably and avoid any possibility of error in the connections.

The thermostat is integrated with the By-me home automation system for temperature control in 2- or 4-pipe systems (heating/air conditioning) and neutral zone (4-pipe systems only), with "boost" function to activate a second source that makes it possible to reach the desired thermal comfort faster. The thermostat has an RGB backlit display with 4 keys to control the temperature set point, to turn the temperature control system on/off and, depending on the type of device (.F or .S or .H) for the specific function that identifies it.

10.2 Devices and functions

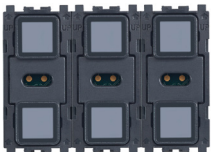
Eikon Tactil consists of the following devices:

	<p>21520.1: Home automation device, 4 independent push buttons or 2 rocker buttons, 4 independent RGB LEDs, to be completed with Eikon Tactil label and cover plate - 2 modules.</p> <p>The device consists of 10 independent functional units: upper left push button, lower left push button, upper right push button, lower right push button, left rocker button, right rocker button, upper left LED, lower left LED, upper right LED, lower right LED.</p>
	<p>21540.1: Home automation device, 6 independent push buttons or 3 rocker buttons, 6 independent RGB LEDs, to be completed with Eikon Tactil label and cover plate - 3 modules.</p> <p>The device consists of 15 independent functional units: upper left push button, lower left push button, upper central push button, lower central push button, upper right push button, lower right push button, left rocker button, central rocker button, right rocker button, upper left LED, lower left LED, upper central LED, lower central LED, upper right LED, lower right LED.</p>
	<p>21514..Touch screen home automation system thermostat for room temperature control (heating and air conditioning), class I temperature control device (contribution 1%) in ON/OFF mode, class IV (contribution 2%) in PID mode, can be interfaced with actuator with proportional analogue outputs 01466.1 to make a class V modulating room thermostat (contribution 3%), 1 input for electronic temperature sensor 20432, 19432 or 14432 or wired temperature sensor 02965.1, 1 programmable digital input, RGB LED backlighting - 2 modules.</p> <ul style="list-style-type: none"> • .F - with 3-speed and proportional FAN COIL control • .S - with STAR control to recall a configurable scenario • .H - with MAKE UP ROOM and DO NOT DISTURB control <p>The thermostat is integrated with the By-me home automation system for temperature control in 2- or 4-pipe systems (heating/air conditioning) and neutral zone (4-pipe systems only), with "boost" function to activate a second source that makes it possible to reach the desired thermal comfort faster. The thermostat has an RGB backlit display with 4 keys to control the temperature set point, to turn the temperature control system on/off and, depending on the type of device (.F or .S or .H) for the specific function that identifies it.</p>

10.3 Functional units of art. 21520.1 and 21540.1

Description of functional units

PUSH BUTTON

- Push button
- Dimmer control
- Roller shutter control
- Timed only control*
- Timed* and ON/OFF control
- Roller shutter control
- Scenario control
- Send value
- Sleep (control for sound system)
- Audio monitoring (control for sound system)

Eikon Tactil devices

ROCKER BUTTON

- Rocker button
- Dimmer control
- Roller shutter control
- Timed only control*
- Timed* and ON/OFF control
- Volume On/Off (volume control for sound system)
- Sleep (control for sound system)
- ch+/track+ (control for sound system)

* Configuration of the timed control is only possible if there is already at least one actuator in the group with a timed function.

LED

- For the LED logic function, only the signalling functional unit can be selected.

Functional unit selection for configuration.

After pressing the configuration push button, before the red LED is lights up (4 s), choose one of the following options:

- Briefly press the button to configure as a push button or as a LED; the LED lighting up white confirms the choice made. From the View Pro App, you can then set operation as a push button or as a signalling LED
- Briefly press the two buttons you want to configure as a rocker button simultaneously; the LED lighting up white confirms the choice made.

After a break of a few seconds, the device enters the configuration of the selected functional unit and the start of configuration is signalled by the red LED lighting up. At the end of the operation the red LED switches off.

10.4 Parameters of art. 21520.1 and 21540.1

Device parameters can be set and/or modified in order to customise their functions and adapt the system to the various installation requirements.

Functional units and their parameters

PUSH BUTTON AND ROCKER BUTTON

- **Push button behaviour:** normal push button ON when the button is pressed, OFF when it is released, reversed push button OFF when pressed, ON when released, toggle on the rising edge, toggle on the falling edge, toggle on both edges, ON only ON when pressed, OFF only OFF when pressed.
Default value "Toggle on the rising edge".
- **Enable scenario saving** (this parameter is for the scenario recall push button that allows you to choose whether, with a long press, the push button sends a request to save the current scenario). Default value "Disabled".
- **Long press time:** from 0.5 s to 30 s with default value 0.5 s.
- **Short/long press behaviour:** normal or reversed with default value "normal". This parameter is also useful in the case of actuators with a timed function to invert the two ON/OFF and timer controls.
 - **Up/Down Orientation:**
 - (ON when the upper button is pressed and OFF when the lower button is pressed or vice-versa).
 - only valid for the dimmer control (ON and up adjustment when the upper button is pressed and OFF and down adjustment when the lower button is pressed or vice-versa).
 - only valid for the roller shutter push button (roller shutter up on long pressing of the upper button and roller shutter down on long pressing of the lower button or vice-versa).
 - ch+ when the upper button is pressed and track+ when the lower button is pressed or vice-versa.
- **Output value** (when the button is pressed the value chosen with this parameter is sent): from 0 to 100% with default value 0%.
- **Roller shutter behaviour** (valid for roller shutter push button and rocker button): parameter allowing you to choose whether or not on release from a long press the stop control is sent to the roller shutter.
- **LED colour:** the colour and brightness of LEDs can be selected as the status of the associated actuator and proximity sensor changes.
In particular, for the push button functional unit, the following can be set:
 - colour with load ON with proximity sensor active;
 - colour with load OFF with proximity sensor active;
 - colour with load ON with proximity sensor inactive;
 - colour with load OFF with proximity sensor inactive.

For the rocker button functional unit, each of the above-mentioned parameters can be set both for the lower LED and for the upper LED.

RGB LED

- **LED behaviour:** the operation can be configured as a one-position stable or a two-position stable. In the case of one-position stable operation the activation time can be set.
- **LED flashing:** configures the behaviour of the LED when it is active (flashing or fixed). The flashing speed can be set (where enabled).
- **LED colour:** the colour and brightness of LEDs can be selected as the status of the associated actuator and proximity sensor changes.
Specifically:
 - colour with status ON with proximity sensor active;
 - colour with status OFF with proximity sensor active;
 - colour with status ON with proximity sensor inactive;
 - colour with status OFF with proximity sensor inactive.

DEVICE PARAMETERS







- **Touch Sensitivity:** used to increase or decrease the device's touch sensitivity, that is the degree of pressure required to actuate a control.
- **Enable Buzzer:** the sound feedback can be enabled/disabled at the pressure of the buttons.

Eikon Tactil devices

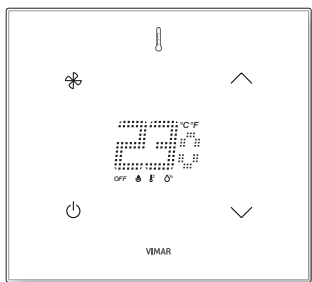
10.5 Configuration of thermostat 21514..

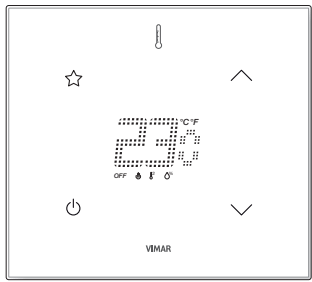
The thermostats consist of **1 Main functional unit (Thermostat)**, **4 Output functional units**, **4 Input functional units** and, depending on the type of thermostat, **the functional units that differentiate its type (F, S and H)**. The Output functional should be configured in the applications in which you desire to include also the actuator to control the climate control source (radiators, fan coils, etc.).

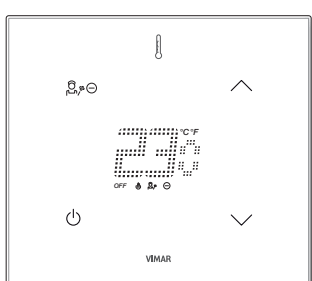
To enter the thermostat configuration mode you need to press the keys shown in the following table simultaneously (quick press).

Article	Keys to be pressed simultaneously
21514.F	  and 
21514.S	  and 
21514.H	  and 

10.6 Parameters of thermostat 21514..

• THERMOSTAT 21514.F

The thermostat consists of 7 functional units with which the respective parameters are paired.

There are also some parameters designed to make those settings linked closely to the device, i.e. display brightness level, LED colour, etc.

Device

- **Enable automatic brightness:** Enables the automatic control of the display brightness.
- **Display brightness level ON:** Sets the brightness level when the thermostat display is not on standby and with automatic brightness disabled.
- **Display brightness level OFF :** Sets the brightness level when the thermostat display is on standby and with automatic brightness disabled.
- **LED colour :** Sets the RGB colour of the LEDs (keys and display) of the thermostat.
- **Probe 2 calibration:** Static calibration value of the internal probe (probe 2). In fact this is an offset to which the temperature value ready by the probe must be summed This parameter is useful in all cases where there is an error with respect to a reference value (installation in a position that alters the correct reading, such as, for instance, a north-facing wall, proximity to the hot or cold water piping) but also to align two thermostats together, to align to a thermometer measurement, etc.

Thermostat functional unit

- **Operating mode ON:** Defines the type of operation (Automatic, Manual, Reduction) associating it with the ON control of the thermostat key.
- **Operating mode OFF:** Defines the type of operation (Absence, Protection, Off) associating it with the OFF control of the thermostat key.
- **Enable boost on auxiliary heating output:** Enables the boot function in heating and indicates whether the output marked as auxiliary must be used for the boost (+ mid season) or only for the mid season.

Eikon Tactil devices

- **Enable boost on auxiliary air conditioning output:** Enables the boost function in air conditioning and indicates whether the output marked as auxiliary must be used for the boost (+ mid season) or only for the mid season.
- **Screed threshold:** Temperature value above which the screed limitation cuts in.
When this limitation is active, the thermostat will close its valve if the temperature measured by the Probe 2 (underfloor heating screed) exceeds the set threshold.
Caution: This is an extra action (and not for safety) that is added to the protection performed by the thermostatic valve prescribed by system regulations.
- **Probe 2:** Sets the use of probe 2 (which is a possible external probe which can be connected to the device); the settable values are the following:
 - Not present = Probe 2 not present.
 - Temperature control (exclusive) = for temperature control, in place of Probe 1.
 - Temperature control (combined) = for temperature control, used as an average with Probe 1 (large rooms).
 - Screen Limit. = for screed limitation.
 - Display = display only (e.g. temperature in another room).
- **Neutral zone range:** Sets the range of the Neutral Zone centred on the related setpoint
In the **Neutral Zone** adjustment mode, the thermostat automatically switches between heating and air conditioning according to the set set point, the temperature measured and considering any neutral zone around the set point defined by the **Neutral Zone Range** parameter (set from 1°C to 5°C in 1°C steps).
For example, if the set point is set to 20°C and the neutral zone range is 2°C, the thermostat will switch the heating on if the temperature falls below 19°C (set point – neutral zone range/2) and will switch on the air conditioning if the temperature rises above 21°C (set point + neutral zone range/2). In this way a band of 2°C around which the thermostat neither heats or cools is defined (thus the name neutral zone).
Caution:
 - The “neutral zone” adjustment can of course be used only on 4-pipe systems (which can both heat and cool at the same time).
 - In the neutral zone adjustment mode, the thermostat only allows Manual and Off operating modes.
- **Heating Setpoint adj. limit:** Defines the setpoint adjustment range limitation in heating mode; the following values can be set:
 - No limitation = the setpoint can be adjusted across all the available range.
 - Range 0 = the current setpoint can be modified by maximum +/- 0.5°C of the setpoint value saved in the memory.
 - Range 1 = as above but +/- 1°C.
 - Range 2 = as above but +/- 2°C.
 - Range 3 = as above but +/- 3°C.
 - Range 4 = as above but +/- 4°C.
 - Range 5 = as above but +/- 5°C.
- **Air conditioning Setpoint adj. limit:** Defines the setpoint adjustment range limitation in air conditioning mode; the following values can be set:
 - No limitation = the setpoint can be adjusted across all the available range.
 - Range 0 = the current setpoint can be modified by maximum +/- 0.5°C of the setpoint value saved in the memory.
 - Range 1 = as above but +/- 1°C.
 - Range 2 = as above but +/- 2°C.
 - Range 3 = as above but +/- 3°C.
 - Range 4 = as above but +/- 4°C.
 - Range 5 = as above but +/- 5°C.
- **View:** Defines what to view in the main screen; the following values can be set:
 - Room temp. = room temperature (normal)
 - Current setpoint = set point temperature
 - Current setpoint delta.
 - Select “current setpoint delta”:
 - in the event of active setpoint adjustment limitations, the display shows the current setpoint delta compared to that locked in the limitation.
Example: **Setpoint adj. limit.** ➔ **Range 2**, the display will show the values from -2°C to +2°C
 - if there are no setpoint adjustment limitations, the display shows the setpoint value.
 - The “current setpoint delta” displayed is therefore used mainly in combination with **Setpoint adj. limit.**
- **Probe 1 calibration:** Static calibration value of the internal probe (probe 1). In fact this is an offset to which the temperature value read by the probe must be summed.
- **Air conditioning Offset Calibration:** Offset to which the value of the temperature read by the Probe in Air conditioning must be summed. For probe 2 the calibration value is already applied in the functional unit of origin.
- **Heating Offset Calibration:** Offset to which the value of the temperature read by the Probe in Heating must be summed. For probe 2 the calibration value is already applied in the functional unit of origin.
- **Fan forcing:** Designed to control the fans irrespective of the valve state.
- **Restart after shutdown:** Defines the behaviour of the thermostat following a restart after shutdown.
- **Value transmission:** Indicates how to force the transmission of a temperature message.
- **Transmission interval:** Indicates the difference in time between 2 values read to generate a temperature message transmission. Designed to set the period of updating the temperature value on the supervisor devices (touch screens, etc.).
- **Aux. heat threshold:** Difference from the setpoint for starting the boost function in heating mode; the function is switched off when the required temperature (setpoint) is reached, increased by the temperature differential.
- **Aux. air-con. threshold:** Difference from the setpoint for starting the boost function in air conditioning mode; the function is switched off when the required temperature (setpoint) is reached, decreased by the temperature differential.
- **Temperature unit:** Sets the unit of measure used to view the temperature on the display
- **Keypad lock:** Enables the keypad lock (disables the keys).

Eikon Tactil devices

Output functional unit

- **Control algorithm:** Defines the algorithm for the room temperature to match that of the setpoint set; the options are the following:
 - On/Off = This is the traditional "threshold" control so that, on exceeding the set temperature increased by the temperature differential (vice versa for air conditioning), the heating is switched off to then be turned back on when the room temperature drops below the set temperature.
 - PID = This is an evolved algorithm that is able to keep the temperature in the environment more stable, increasing comfort; this algorithm switches the system on and off appropriately so there will be a gradual increase or decrease in the thermal (or refrigerating) power of the system itself. To fully exploit the performances, it must be appropriately calibrated according to the type of environment or heating system, by setting the related parameters.
- **Hysteresis:** Sets the hysteresis value to be used in the case of an on/off algorithm (can be set from 0.1°C to 1°C in 0.1°C steps)
- **PWM time:** Sets the length of a PWM cycle in the case of a PID algorithm for controlling on/off valves.
It therefore corresponds to the **time** in which a cycle of adjustment is completed; the shorter this time, the better the adjustment but the temperature control system is under greater stress. This parameter setting is thus the result of a compromise between the accuracy of the dimmer and the load on the system; in general, the rule is that T_b can be that much higher (and therefore put fewer demands on the system), the slower the system or the larger the environment to regulate.
Caution: The value must be much greater than the on and off times of the valves
- **Band (P):** Parameter used by the PID algorithm to calculate the coeff. $K_p = 100/B_p$.
Corresponds to the breadth of proportional adjustment range: starting from the set temperature, this value represents the temperature range in which the system power goes from 0% to 100%.
For example: with the (heating) temperature, set to 20.0°C and Band (P) = 4.0°C, the thermostat runs the heating system at 100% when **room T.** is ≤ 16.0 °C; as this temperature increases, the system power is consequently lowered down to 0% when the room temperature reaches 20°C. The value must be set consistently with the thermal capacity of the environment controlled; in general, it is recommended to use small values for environments with a good level of thermal insulation and vice-versa.
- **Time (I):** Parameter used by the PID algorithm to calculate the coeff. $K_i = K_p/T_i$.
Corresponds to the time after which, when equal to the deviation from the setpoint (error), the additional component generates a contribution equal to that generated by the proportional component. The integral contribution is used to reduce the error on full operation if thermal energy is lost in the environment controlled, as this contribution increases according to the time during which the setpoint is not reached. If this value is not set perfectly, it can cause transients with oscillations around the setpoint or it may take longer to reach the setpoint.
- **Time (D):** Parameter used by the PID algorithm to calculate the coeff. $K_d = K_p * T_d$.
Corresponds to the time only the proportional action would take to generate a control signal equal to that produced by the derivative action. The derivative contribution opposes the system variations and has no role in eliminating the error but is used to stabilise the control operations, particularly in systems that are characterised by sudden variations. The derivative contribution must be enabled with care, particularly in systems with long dead times, as this could make the control chain unstable; generally the most appropriate algorithm in these cases corresponds to type PI (proportional-integral).
- **Speed control:** It is possible to select two different control modes:
 - Interlock: the thermostat sends a control message exclusively at a single speed: V1, V2 or V3
 - Step-step: the thermostat sends a message cumulatively: V1, V1+V2, V1+V2+V3
- **Start delay:** It sets the delay time of the fan start.
This parameter is used only during the operating or adjustment mode change while it is not used during temperature control (for example if the thermostat switches off the output and then switches it back on)
- **Speed band:** It defines the thermal delta to run the fan coil fan at maximum speed.
The speed scale (in the case of an on/off algorithm) is defined in correspondence to the difference between the room temperature and the current Setpoint.

Input functional unit Probe 2 thermostat

- **Value transmission:** Indicates how to force the transmission of a temperature message.
- **Transmission interval:** Indicates the difference in time between 2 values read to generate a temperature message transmission. Designed to set the period of updating the temperature value on the supervisor devices (touch screens, etc.).

Input functional unit Contact thermostat

- **Reaction time:** Depending on how the "Operation" parameter has been set with reference to the window or the boiler shutdown, it sets the reaction time in the event that a signal arrives; in actual fact, it indicates after how long the thermostat shutdown is activated following the signalling.
Example:
When the window is closed the heating/air conditioning is on; if the window is opened the heating/air conditioning stays on for the time set in the **Reaction time**. If within that time interval the window is closed, the heating/air conditioning remains on.
- **Reactivation time:** Depending on how the "Operation" parameter has been set with reference to the window or boiler shutdown, it sets the reactivation time if a window warning is received; in fact, it indicates after how much time the thermostat shutdown should be removed following the signalling.
Example:
When the window is closed the heating/air conditioning is on; if the window is opened the heating/air conditioning turns off and remains so for the time set in the **Reaction time**. At the end of the time interval the heating/air conditioning comes back on whether or not the window has been closed.
- **Operation:** Defines what to view in the main screen; the following values can be set:
 - Window open
 - Shutdown alarm
- **Control input report:** Defines the behaviour of the alarm upon closing or opening of the input.

Input functional unit window contact from BUS

- **Reaction time:** Sets the reaction time if a window warning is received; in fact, it indicates after how much time the thermostat block should come on if a window is open.
Example:
When the window is closed the heating/air conditioning is on; if the window is opened the heating/air conditioning stays on for the time set in the **Reaction time**. If within that time interval the window is closed, the heating/air conditioning remains on.

Eikon Tactil devices

- **Reactivation time:** Sets the reactivation time if a window warning is received; in fact, it indicates after how much time the thermostat block should be removed due to an open window.

Example:

When the window is closed the heating/air conditioning is on; if the window is opened the heating/air conditioning turns off and remains so for the time set in the **Reaction time**. At the end of the time interval the heating/air conditioning comes back on whether or not the window has been closed.

- **Control input report:** Defines the behaviour of the alarm upon closing or opening of the input.

Input functional unit Block contact from BUS

- **Reaction time:** Sets the reaction time if an open contact signal is received; in fact, it indicates after how much time the thermostat shutdown should come on if a boiler shuts down.

Example:

When the contact is closed, the boiler is working properly; if the contact opens the thermostat stays on for an amount of time equal to **Reaction time**. If within that time interval the boiler resumes working, the thermostat remains on.

- **Reactivation time:** Sets the reactivation time if an open contact signal is received; in fact, it indicates after how much time the thermostat shutdown should be removed if a boiler shuts down.

Example:

When the contact is closed, the boiler is working properly; if the contact opens the thermostat is turned off and remains off for an amount of time equal to **Reactivation time**. At the end operation of the time interval the thermostat comes back on whether or not the boiler has resumed operation.

- **Control input report:** Defines the behaviour of the alarm upon closing or opening of the input.

Humidity Functional Unit

- **Probe calibration:** It is the humidity measurement calibration value; this value is added to or subtracted from humidity measured by the sensor of the same group to obtain the desired value.

• THERMOSTAT 21514.H

The thermostat consists of 8 functional units with which the respective parameters are paired.

There are also some parameters designed to make those settings linked closely to the device, i.e. display brightness level, LED colour, etc.

- **Enable automatic brightness:** Enables the automatic control of the display brightness.
- **Display brightness level ON:** Sets the display brightness level when the thermostat is on and with automatic brightness disabled.
- **Display brightness level OFF :** Sets the display brightness level when the thermostat is off and with automatic brightness disabled.
- **LED colour :** Sets the RGB colour of the LEDs (keys and display) of the thermostat.
- **Probe 2 calibration:** Static calibration value of the internal probe (probe 2). In fact this is an offset to which the temperature value ready by the probe must be summed. This parameter is useful in all cases where there is an error with respect to a reference value (installation in a position that alters the correct reading, such as, for instance, a north-facing wall, proximity to the hot or cold water piping) but also to align two thermostats together, to align to a thermometer measurement, etc.

Thermostat functional unit

- **Operating mode ON:** Defines the type of operation (Automatic, Manual, Reduction) associating it with the ON control of the thermostat key.
- **Operating mode OFF:** Defines the type of operation (Absence, Protection, Off) associating it with the OFF control of the thermostat key.
- **Enable boost on auxiliary heating output:** Enables the boot function in heating and indicates whether the output marked as auxiliary must be used for the boost (+ mid season) or only for the mid season.
- **Enable boost on auxiliary air conditioning output:** Enables the boot function in air conditioning and indicates whether the output marked as auxiliary must be used for the boost (+ mid season) or only for the mid season.
- **Screed threshold:** Temperature value above which the screed limitation cuts in.
When this limitation is active, the thermostat will close its valve if the temperature measured by the Probe 2 (underfloor heating screed) exceeds the set threshold.
Caution: This is an extra action (and not for safety) that is added to the protection performed by the thermostatic valve prescribed by system regulations.
- **Probe 2:** Sets the use of probe 2 (which is a possible external probe which can be connected to the device); the settable values are the following:
 - Not present = Probe 2 not present.
 - Temperature control (exclusive) = for temperature control, in place of Probe 1.
 - Temperature control (combined) = for temperature control, used as an average with Probe 1 (large rooms).
 - Screen Limit. = for screed limitation.
 - Display = display only (e.g. temperature in another room).
- **Neutral zone range:** Sets the range of the Neutral Zone centred on the related setpoint
In the **Neutral Zone** adjustment mode, the thermostat automatically switches between heating and air conditioning according to the set set point, the temperature measured and considering any neutral zone around the set point defined by the **Neutral Zone Range** parameter (set from 1°C to 5°C in 1°C steps).
For example, if the set point is set to 20°C and the neutral zone range is 2°C, the thermostat will switch the heating on if the temperature falls below 19°C (set point – neutral zone range/2) and will switch on the air conditioning if the temperature rises above 21°C (set point + neutral zone range/2). In this way a band of 2°C around which the thermostat neither heats or cools is defined (thus the name neutral zone).
Caution:
 - The "neutral zone" adjustment can of course be used only on 4-pipe systems (which can both heat and cool at the same time).
 - In the neutral zone adjustment mode, the thermostat only allows Manual and Off operating modes.

Eikon Tactil devices

- **Heating Setpoint adj. limit:** Defines the setpoint adjustment range limitation in heating mode; the following values can be set:
 - No limitation = the setpoint can be adjusted across all the available range.
 - Range 0 = the current setpoint can be modified by maximum +/- 0.5°C of the setpoint value saved in the memory.
 - Range 1 = as above but +/- 1°C.
 - Range 2 = as above but +/- 2°C.
 - Range 3 = as above but +/- 3°C.
 - Range 4 = as above but +/- 4°C.
 - Range 5 = as above but +/- 5°C.
- **Air conditioning Setpoint adj. limit:** Defines the setpoint adjustment range limitation in air conditioning mode; the following values can be set:
 - No limitation = the setpoint can be adjusted across all the available range.
 - Range 0 = the current setpoint can be modified by maximum +/- 0.5°C of the setpoint value saved in the memory.
 - Range 1 = as above but +/- 1°C.
 - Range 2 = as above but +/- 2°C.
 - Range 3 = as above but +/- 3°C.
 - Range 4 = as above but +/- 4°C.
 - Range 5 = as above but +/- 5°C.
- **View:** Defines what to view in the main screen; the following values can be set:
 - Room temp. = room temperature (normal)
 - Current setpoint = set point temperature
 - Current setpoint delta.
 - Select "current setpoint delta":
 - in the event of active setpoint adjustment limitations, the display shows the current setpoint delta compared to that locked in the limitation.
Example: **Setpoint adj. limit.** ➔ **Range 2**, the display will show the values from -2°C to +2°C
 - if there are no setpoint adjustment limitations, the display shows the setpoint value.
 - The "current setpoint delta" displayed is therefore used mainly in combination with **Setpoint adj. limit.**
- **Probe 1 calibration:** Static calibration value of the internal probe (probe 1). In fact this is an offset to which the temperature value read by the probe must be summed.
- **Air conditioning Offset Calibration:** Offset to which the value of the temperature read by the Probe in Air conditioning must be summed. For probe 2 the calibration value is already applied in the functional unit of origin.
- **Heating Offset Calibration:** Offset to which the value of the temperature read by the Probe in Heating must be summed. For probe 2 the calibration value is already applied in the functional unit of origin.
- **Fan forcing:** Designed to control the fans irrespective of the valve state.
- **Restart after shutdown:** Defines the behaviour of the thermostat following a restart after shutdown.
- **Value transmission:** Indicates how to force the transmission of a temperature message.
- **Transmission interval:** Indicates the difference in time between 2 values read to generate a temperature message transmission. Designed to set the period of updating the temperature value on the supervisor devices (touch screens, etc.).
- **Aux. heat threshold:** Difference from the setpoint for starting the boost function in heating mode; the function is switched off when the required temperature (setpoint) is reached, increased by the temperature differential.
- **Aux. air-con. threshold:** Difference from the setpoint for starting the boost function in air conditioning mode; the function is switched off when the required temperature (setpoint) is reached, decreased by the temperature differential.
- **Temperature unit:** Sets the unit of measure used to view the temperature on the display
- **Keypad lock:** Enables the keypad lock (disables the keys).

Output functional unit

- **Control algorithm:** Defines the algorithm for the room temperature to match that of the setpoint set; the options are the following:
 - On/Off = This is the traditional "threshold" control so that, on exceeding the set temperature increased by the temperature differential (vice versa for air conditioning), the heating is switched off to then be turned back on when the room temperature drops below the set temperature.
 - PID = This is an evolved algorithm that is able to keep the temperature in the environment more stable, increasing comfort; this algorithm switches the system on and off appropriately so there will be a gradual increase or decrease in the thermal (or refrigerating) power of the system itself. To fully exploit the performances, it must be appropriately calibrated according to the type of environment or heating system, by setting the related parameters.
- **Hysteresis:** Sets the hysteresis value to be used in the case of an on/off algorithm (can be set from 0.1°C to 1°C in 0.1°C steps)
- **PWM time:** Sets the length of a PWM cycle in the case of a PID algorithm for controlling on/off valves.
It therefore corresponds to the **time** in which a cycle of adjustment is completed; the shorter this time, the better the adjustment but the temperature control system is under greater stress. This parameter setting is thus the result of a compromise between the accuracy of the dimmer and the load on the system; in general, the rule is that T_b can be that much higher (and therefore put fewer demands on the system), the slower the system or the larger the environment to regulate.
Caution: The value must be much greater than the on and off times of the valves
- **Band (P):** Parameter used by the PID algorithm to calculate the coeff. $K_p = 100/B_p$.
Corresponds to the breadth of proportional adjustment range: starting from the set temperature, this value represents the temperature range in which the system power goes from 0% to 100%.
For example: with the (heating) temperature, set to 20.0°C and Band (P) = 4.0°C, the thermostat runs the heating system at 100% when **room T.** is ≤ 16.0 °C; as this temperature increases, the system power is consequently lowered down to 0% when the room temperature reaches 20°C. The value must be set consistently with the thermal capacity of the environment controlled; in general, it is recommended to use small values for environments with a good level of thermal insulation and vice-versa.

Eikon Tactil devices

- **Time (I):** Parameter used by the PID algorithm to calculate the coeff. $K_i = K_p/T_i$.
Corresponds to the time after which, when equal to the deviation from the setpoint (error), the additional component generates a contribution equal to that generated by the proportional component. The integral contribution is used to reduce the error on full operation if thermal energy is lost in the environment controlled, as this contribution increases according to the time during which the setpoint is not reached. If this value is not set perfectly, it can cause transients with oscillations around the setpoint or it may take longer to reach the setpoint.
- **Time (D):** Parameter used by the PID algorithm to calculate the coeff. $K_d = K_p * T_d$.
Corresponds to the time only the proportional action would take to generate a control signal equal to that produced by the derivative action. The derivative contribution opposes the system variations and has no role in eliminating the error but is used to stabilise the control operations, particularly in systems that are characterised by sudden variations. The derivative contribution must be enabled with care, particularly in systems with long dead times, as this could make the control chain unstable; generally the most appropriate algorithm in these cases corresponds to type PI (proportional-integral).
- **Speed control:** It is possible to select two different control modes:
 - Interlock: the thermostat sends a control message exclusively at a single speed: V1, V2 or V3
 - Step-step: the thermostat sends a message cumulatively: V1, V1+V2, V1+V2+V3
- **Start delay:** It sets the delay time of the fan start.
This parameter is used only during the operating or adjustment mode change while it is not used during temperature control (for example if the thermostat switches off the output and then switches it back on)
- **Speed band:** It defines the thermal delta to run the fan coil fan at maximum speed.
The speed scale (in the case of an on/off algorithm) is defined in correspondence to the difference between the room temperature and the current Setpoint

Input functional unit Probe 2 thermostat

- **Value transmission:** Indicates how to force the transmission of a temperature message.
- **Transmission interval:** Indicates the difference in time between 2 values read to generate a temperature message transmission. Designed to set the period of updating the temperature value on the supervisor devices (touch screens, etc.).

Input functional unit Contact thermostat

- **Reaction time:** Depending on how the "Operation" parameter has been set with reference to the window or the boiler shutdown, it sets the reaction time in the event that a signal arrives; in actual fact, it indicates after how long the thermostat shutdown is activated following the signalling.
Example:
When the window is closed the heating/air conditioning is on; if the window is opened the heating/air conditioning stays on for the time set in the **Reaction time**. If within that time interval the window is closed, the heating/air conditioning remains on.
- **Reactivation time:** Depending on how the "Operation" parameter has been set with reference to the window or the boiler shutdown, it sets the reactivation time if a signalling is received; in fact, it indicates after how much time the thermostat shutdown should be removed following the signalling.
Example:
When the window is closed the heating/air conditioning is on; if the window is opened the heating/air conditioning turns off and remains so for the time set in the **Reaction time**. At the end of the time interval the heating/air conditioning comes back on whether or not the window has been closed.
- **Operation:** Defines what to view in the main screen; the following values can be set:
 - Window open
 - Shutdown alarm
- **Control input report:** Defines the behaviour of the alarm upon closing or opening of the input.

Input functional unit window contact from BUS

- **Reaction time:** Sets the reaction time if a window warning is received; in fact, it indicates after how much time the thermostat block should come on if a window is open.
Example:
When the window is closed the heating/air conditioning is on; if the window is opened the heating/air conditioning stays on for the time set in the **Reaction time**. If within that time interval the window is closed, the heating/air conditioning remains on.
- **Reactivation time:** Sets the reactivation time if a window warning is received; in fact, it indicates after how much time the thermostat block should be removed due to an open window.
Example:
When the window is closed the heating/air conditioning is on; if the window is opened the heating/air conditioning turns off and remains so for the time set in the **Reaction time**. At the end of the time interval the heating/air conditioning comes back on whether or not the window has been closed.
- **Control input report:** Defines the behaviour of the alarm upon closing or opening of the input.

Input functional unit Block contact from BUS

- **Reaction time:** Sets the reaction time if an open contact signal is received; in fact, it indicates after how much time the thermostat shutdown should come on if a boiler shuts down.
Example:
When the contact is closed, the boiler is working properly; if the contact opens the thermostat stays on for an amount of time equal to **Reaction time**. If within that time interval the boiler resumes working, the thermostat remains on.
- **Reactivation time:** Sets the reactivation time if an open contact signal is received; in fact, it indicates after how much time the thermostat shutdown should be removed if a boiler shuts down.
Example:
When the contact is closed, the boiler is working properly; if the contact opens the thermostat is turned off and remains off for an amount of time equal to **Reactivation time**. At the end operation of the time interval the thermostat comes back on whether or not the boiler has resumed operation.
- **Control input report:** Defines the behaviour of the alarm upon closing or opening of the input.

Eikon Tactil devices

Key functional unit

- **LED colour:** Sets the RGB colour of the LED of the DO NOT DISTURB key.

key functional unit

- **LED colour:** Sets the RGB colour of the LED of the MAKE UP ROOM key.

• THERMOSTAT 21514.S

The thermostat consists of 8 functional units with which the respective parameters are paired.

There are also some parameters designed to make those settings linked closely to the device, i.e. display brightness level, LED colour, etc.

- **Enable automatic brightness:** Enables the automatic control of the display brightness.
- **Display brightness level ON:** Sets the display brightness level when the thermostat is on and with automatic brightness disabled.
- **Display brightness level OFF :** Sets the display brightness level when the thermostat is off and with automatic brightness disabled.
- **LED colour :** Sets the RGB colour of the LEDs (keys and display) of the thermostat.
- **Probe 2 calibration:** Static calibration value of the internal probe (probe 2). In fact this is an offset to which the temperature value ready by the probe must be summed. This parameter is useful in all cases where there is an error with respect to a reference value (installation in a position that alters the correct reading, such as, for instance, a north-facing wall, proximity to the hot or cold water piping) but also to align two thermostats together, to align to a thermometer measurement, etc.

Thermostat functional unit

Operating mode ON: Defines the type of operation (Automatic, Manual, Reduction) associating it with the ON control of the thermostat key.

- **Operating mode OFF:** Defines the type of operation (Absence, Protection, Off) associating it with the OFF control of the thermostat key.
- **Enable boost on auxiliary heating output:** Enables the boost function in heating and indicates whether the output marked as auxiliary must be used for the boost (+ mid season) or only for the mid season.
- **Enable boost on auxiliary air conditioning output:** Enables the boost function in air conditioning and indicates whether the output marked as auxiliary must be used for the boost (+ mid season) or only for the mid season.
- **Screed threshold:** Temperature value above which the screed limitation cuts in.
When this limitation is active, the thermostat will close its valve if the temperature measured by the Probe 2 (underfloor heating screed) exceeds the set threshold.
Caution: This is an extra action (and not for safety) that is added to the protection performed by the thermostatic valve prescribed by system regulations.
- **Probe 2:** Sets the use of probe 2 (which is a possible external probe which can be connected to the device); the settable values are the following:
 - Not present = Probe 2 not present.
 - Temperature control (exclusive) = for temperature control, in place of Probe 1.
 - Temperature control (combined) = for temperature control, used as an average with Probe 1 (large rooms).
 - Screen Limit. = for screed limitation.
 - Display = display only (e.g. temperature in another room).
- **Neutral zone range:** Sets the range of the Neutral Zone centred on the related setpoint
In the **Neutral Zone** adjustment mode, the thermostat automatically switches between heating and air conditioning according to the set set point, the temperature measured and considering any neutral zone around the set point defined by the **Neutral Zone Range** parameter (set from 1°C to 5°C in 1°C steps).
For example, if the set point is set to 20°C and the neutral zone range is 2°C, the thermostat will switch the heating on if the temperature falls below 19°C (set point – neutral zone range/2) and will switch on the air conditioning if the temperature rises above 21°C (set point + neutral zone range/2). In this way a band of 2°C around which the thermostat neither heats or cools is defined (thus the name neutral zone).
Caution:
 - The “neutral zone” adjustment can of course be used only on 4-pipe systems (which can both heat and cool at the same time).
 - In the neutral zone adjustment mode, the thermostat only allows Manual and Off operating modes.
- **Heating Setpoint adj. limit:** Defines the setpoint adjustment range limitation in heating mode; the following values can be set:
 - No limitation = the setpoint can be adjusted across all the available range.
 - Range 0 = the current setpoint can be modified by maximum +/- 0.5°C of the setpoint value saved in the memory.
 - Range 1 = as above but +/- 1°C.
 - Range 2 = as above but +/- 2°C.
 - Range 3 = as above but +/- 3°C.
 - Range 4 = as above but +/- 4°C.
 - Range 5 = as above but +/- 5°C.
- **Air conditioning Setpoint adj. limit:** Defines the setpoint adjustment range limitation in air conditioning mode; the following values can be set:
 - No limitation = the setpoint can be adjusted across all the available range.
 - Range 0 = the current setpoint can be modified by maximum +/- 0.5°C of the setpoint value saved in the memory.
 - Range 1 = as above but +/- 1°C.
 - Range 2 = as above but +/- 2°C.
 - Range 3 = as above but +/- 3°C.
 - Range 4 = as above but +/- 4°C.
 - Range 5 = as above but +/- 5°C.
- **View:** Defines what to view in the main screen; the following values can be set:

Eikon Tactil devices

- Room temp. = room temperature (normal)
- Current setpoint = set point temperature
- Current setpoint delta.

Select "current setpoint delta":

- in the event of active setpoint adjustment limitations, the display shows the current setpoint delta compared to that locked in the limitation.
Example: **Setpoint adj. limit.** → **Range 2**, the display will show the values from -2°C to +2°C
- if there are no setpoint adjustment limitations, the display shows the setpoint value.

The "current setpoint delta" displayed is therefore used mainly in combination with **Setpoint adj. limit.**

- **Probe 1 calibration:** Static calibration value of the internal probe (probe 1). In fact this is an offset to which the temperature value read by the probe must be summed.
- **Air conditioning Offset Calibration:** Offset to which the value of the temperature read by the Probe in Air conditioning must be summed. For probe 2 the calibration value is already applied in the functional unit of origin.
- **Heating Offset Calibration:** Offset to which the value of the temperature read by the Probe in Heating must be summed. For probe 2 the calibration value is already applied in the functional unit of origin.
- **Fan forcing:** Designed to control the fans irrespective of the valve state.
- **Restart after shutdown:** Defines the behaviour of the thermostat following a restart after shutdown.
- **Value transmission:** Indicates how to force the transmission of a temperature message.
- **Transmission interval:** Indicates the difference in time between 2 values read to generate a temperature message transmission. Designed to set the period of updating the temperature value on the supervisor devices (touch screens, etc.).
- **Aux. heat threshold:** Difference from the setpoint for starting the boost function in heating mode; the function is switched off when the required temperature (setpoint) is reached, increased by the temperature differential.
- **Aux. air-con. threshold:** Difference from the setpoint for starting the boost function in air conditioning mode; the function is switched off when the required temperature (setpoint) is reached, decreased by the temperature differential.
- **Temperature unit:** Sets the unit of measure used to view the temperature on the display
- **Keypad lock:** Enables the keypad lock (disables the keys).

Output functional unit

- **Control algorithm:** Defines the algorithm for the room temperature to match that of the setpoint set; the options are the following:
 - On/Off = This is the traditional "threshold" control so that, on exceeding the set temperature increased by the temperature differential (vice versa for air conditioning), the heating is switched off to then be turned back on when the room temperature drops below the set temperature.
 - PID = This is an evolved algorithm that is able to keep the temperature in the environment more stable, increasing comfort; this algorithm switches the system on and off appropriately so there will be a gradual increase or decrease in the thermal (or refrigerating) power of the system itself. To fully exploit the performances, it must be appropriately calibrated according to the type of environment or heating system, by setting the related parameters.
- **Hysteresis:** Sets the hysteresis value to be used in the case of an on/off algorithm (can be set from 0.1°C to 1°C in 0.1°C steps)
- **PWM time:** Sets the length of a PWM cycle in the case of a PID algorithm for controlling on/off valves.
It therefore corresponds to the **time** in which a cycle of adjustment is completed; the shorter this time, the better the adjustment but the temperature control system is under greater stress. This parameter setting is thus the result of a compromise between the accuracy of the dimmer and the load on the system; in general, the rule is that T_b can be that much higher (and therefore put fewer demands on the system), the slower the system or the larger the environment to regulate.
Caution: The value must be much greater than the on and off times of the valves
- **Band (P):** Parameter used by the PID algorithm to calculate the coeff. $K_p = 100/B_p$.
Corresponds to the breadth of proportional adjustment range: starting from the set temperature, this value represents the temperature range in which the system power goes from 0% to 100%.
For example: with the (heating) temperature, set to 20.0°C and Band (P) = 4.0°C, the thermostat runs the heating system at 100% when **room T.** is ≤ 16.0 °C; as this temperature increases, the system power is consequently lowered down to 0% when the room temperature reaches 20°C. The value must be set consistently with the thermal capacity of the environment controlled; in general, it is recommended to use small values for environments with a good level of thermal insulation and vice-versa.
- **Time (I):** Parameter used by the PID algorithm to calculate the coeff. $K_i = K_p/T_i$.
Corresponds to the time after which, when equal to the deviation from the setpoint (error), the additional component generates a contribution equal to that generated by the proportional component. The integral contribution is used to reduce the error on full operation if thermal energy is lost in the environment controlled, as this contribution increases according to the time during which the setpoint is not reached. If this value is not set perfectly, it can cause transients with oscillations around the setpoint or it may take longer to reach the setpoint.
- **Time (D):** Parameter used by the PID algorithm to calculate the coeff. $K_d = K_p * T_d$.
Corresponds to the time only the proportional action would take to generate a control signal equal to that produced by the derivative action. The derivative contribution opposes the system variations and has no role in eliminating the error but is used to stabilise the control operations, particularly in systems that are characterised by sudden variations. The derivative contribution must be enabled with care, particularly in systems with long dead times, as this could make the control chain unstable; generally the most appropriate algorithm in these cases corresponds to type PI (proportional-integral).
- **Speed control:** It is possible to select two different control modes:
 - Interlock: the thermostat sends a control message exclusively at a single speed: V1, V2 or V3
 - Step-step: the thermostat sends a message cumulatively: V1, V1+V2, V1+V2+V3
- **Start delay:** It sets the delay time of the fan start.
This parameter is used only during the operating or adjustment mode change while it is not used during temperature control (for example if the thermostat switches off the output and then switches it back on)
- **Speed band:** It defines the thermal delta to run the fan coil fan at maximum speed.
The speed scale (in the case of an on/off algorithm) is defined in correspondence to the difference between the room temperature and the current Setpoint.

Eikon Tactil devices

Input functional unit Probe 2 thermostat

- **Value transmission:** Indicates how to force the transmission of a temperature message.
- **Transmission interval:** Indicates the difference in time between 2 values read to generate a temperature message transmission. Designed to set the period of updating the temperature value on the supervisor devices (touch screens, etc.).

Input functional unit Contact thermostat

- **Reaction time:** Depending on how the "Operation" parameter has been set with reference to the window or the boiler shutdown, it sets the reaction time in the event that a signal arrives; in actual fact, it indicates after how long the thermostat shutdown is activated following the signalling.

Example:

When the window is closed the heating/air conditioning is on; if the window is opened the heating/air conditioning stays on for the time set in the **Reaction time**. If within that time interval the window is closed, the heating/air conditioning remains on.

- **Reactivation time:** Depending on how the "Operation" parameter has been set with reference to the window or the boiler shutdown, it sets the reactivation time if a signalling is received; in fact, it indicates after how much time the thermostat shutdown should be removed following the signalling.

Example:

When the window is closed the heating/air conditioning is on; if the window is opened the heating/air conditioning turns off and remains so for the time set in the **Reaction time**. At the end of the time interval the heating/air conditioning comes back on whether or not the window has been closed.

- **Operation:** Defines what to view in the main screen; the following values can be set:
 - Window open
 - Shutdown alarm
- **Control input report:** Defines the behaviour of the alarm upon closing or opening of the input.

Input functional unit window contact from BUS

- **Reaction time:** Sets the reaction time if a window warning is received; in fact, it indicates after how much time the thermostat block should come on if a window is open.

Example:

When the window is closed the heating/air conditioning is on; if the window is opened the heating/air conditioning stays on for the time set in the **Reaction time**. If within that time interval the window is closed, the heating/air conditioning remains on.

- **Reactivation time:** Sets the reactivation time if a window warning is received; in fact, it indicates after how much time the thermostat block should be removed due to an open window.

Example:

When the window is closed the heating/air conditioning is on; if the window is opened the heating/air conditioning turns off and remains so for the time set in the **Reaction time**. At the end of the time interval the heating/air conditioning comes back on whether or not the window has been closed.

- **Control input report:** Defines the behaviour of the alarm upon closing or opening of the input.

Input functional unit Block contact from BUS

- **Reaction time:** Sets the reaction time if an open contact signal is received; in fact, it indicates after how much time the thermostat shutdown should come on if a boiler shuts down.

Example:

When the contact is closed, the boiler is working properly; if the contact opens the thermostat stays on for an amount of time equal to **Reaction time**. If within that time interval the boiler resumes working, the thermostat remains on.

- **Reactivation time:** Sets the reactivation time if an open contact signal is received; in fact, it indicates after how much time the thermostat shutdown should be removed if a boiler shuts down.

Example:

When the contact is closed, the boiler is working properly; if the contact opens the thermostat is turned off and remains off for an amount of time equal to **Reactivation time**. At the end operation of the time interval the thermostat comes back on whether or not the boiler has resumed operation.

- **Control input report:** Defines the behaviour of the alarm upon closing or opening of the input.

☆ key functional unit

- **Push button behaviour:** normal push button ON when the button is pressed, OFF when it is released, reversed push button OFF when pressed, ON when released, toggle on the rising edge, toggle on the falling edge, toggle on both edges, ON only ON when pressed, OFF only OFF when pressed.
Default value "Toggle on the rising edge".
- **Long press time:** from 0.5 ms to 30 s with default value 0.5 s.
- **Short/long press behaviour:** normal or reversed with default value "normal". This parameter is also useful in the case of actuators with a timed function to invert the two ON/OFF and timer controls.
- **Up/Down Orientation:**
 - (ON when the upper button is pressed and OFF when the lower button is pressed or vice-versa).
 - only valid for the dimmer control (ON and up adjustment when the upper button is pressed and OFF and down adjustment when the lower button is pressed or vice-versa).
 - only valid for the roller shutter push button (roller shutter up on long pressing of the upper button and roller shutter down on long pressing of the lower button or vice-versa).
 - ch+ when the upper button is pressed and track+ when the lower button is pressed or vice-versa.
- **Output value** (when the button is pressed the value chosen with this parameter is sent): from 0 to 100% with default value 0%.

Eikon Tactil devices

- **Roller shutter behaviour** (valid for roller shutter push button and rocker button): parameter allowing you to choose whether or not on release from a long press the stop control is sent to the roller shutter.
- **LED colour**: the colour and brightness of LEDs can be selected as the state of the paired actuator and proximity sensor changes.

In particular, for the push button functional unit, the following can be set:

- colour with load ON with proximity sensor active;
- colour with load OFF with proximity sensor active;
- colour with load ON with proximity sensor inactive;
- colour with load OFF with proximity sensor inactive.

Humidity Functional Unit

- **Probe calibration**: It is the humidity measurement calibration value; this value is added to or subtracted from humidity measured by the sensor of the same group to obtain the desired value.

11. XT PLATFORM DEVICES

11.1. General characteristics

The XT platform stands out for its ample scalability and expandable controls; it allows you to move the front to other control devices, without requiring any wiring. It stands out for the absolute flatness of the control and for the innovative styling of the home automation system controls, is extremely easy to use and ergonomically designed across the entire surface.







Thanks to its modularity and scalability, it is suitable for any installation requirements thanks to devices that are scalable in time and extremely user-friendly; from a simple control for lights and roller shutters, to temperature management and even the activation of scenarios to achieve a home automation system that is always up-to-date and functional.

It can be installed in 2-3-4 module mounting boxes and comprises:



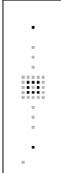

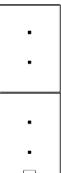
- interchangeable front controls with 2 or 4 presses/functions;
- possibility of 4 front controls on the 3-module mounting box (up to 16 activations);
- double relay actuators (up to 4 loads per 3-module mounting box) hooking onto the back of the mounting frame and supplied via an innovative connection system;
- controls and thermostat;
- possibility of expanding and relocating functions by simply swapping modules without dismantling the lighting device (also post-installation benefits);
- matching styling between control devices and socket outlets;
- possibility of customising controls with a wide range of symbols to identify the function.

11.2 Devices and functions

The XT platform devices are the following:

	<p>32001: XT device power supply node for By-me home automation system, 29 VDC bus power supply, to be installed on XT mounting frames, to be completed with By-me XT front modules.</p>
	<p>32002: XT electronic control device for By-me home automation system with 100-240 V 50/60 Hz relay output for 500 W incandescent lamps, 100 W LED lamps, 250 VA electronic transformers, 120 W fluorescent lamps, 1 roller shutter operated by 2 A cosϕ 0.6 motor, to be installed on XT mounting frames, to be completed with By-me XT front modules.</p>
	<p>32021.x: XT By-me control device for home automation system with 2 push buttons, also configurable as 1 rocker button, LED with status function and visible in darkness with brightness control, central LED matrix to customise symbols or animation - 1 front module.</p>
	<p>32023.x: XT control device for By-me home automation system with 2 push buttons, also configurable as 1 rocker button, proximity function, LED matrix with status function or for scenario animation and visible in darkness with brightness control, central LED matrix to customise symbols or animation - 1 front module.</p>
	<p>32024.x: XT control device for By-me home automation system with 4 push buttons, proximity function, LED with status function and visible in darkness with brightness control - 1 front module.</p>
	<p>32031.G: XT control device for By-me home automation system with 2 push buttons, also configurable as 1 rocker button, LED with status function and visible in darkness with brightness control, central label to customise symbols, black - 1 front module.</p>

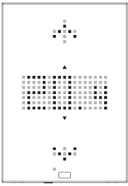
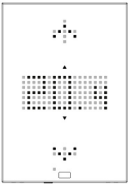
XT platform devices

	<p>32033.G: XT control device for By-me home automation system with 2 push buttons customisable with labels, also configurable as 1 rocker button, proximity function, labels with status function and visible in darkness with brightness control, central label to customise symbols, black - 1 front module.</p>
	<p>32034.G: XT control device for By-me home automation system with 4 push buttons customisable with labels, proximity function, labels with status function and visible in darkness with brightness control, black control - 1 front module.</p>
	<p>32041.x: XT thermostat for By-me home automation system for room temperature control (heating and air conditioning), 2- and 4-pipe system management, 3-speed and proportional fan coil control, class I temperature control device (contribution 1%) in ON/OFF mode, class IV (contribution 2%) in PID mode, can be interfaced with actuator with proportional analogue outputs 01466.1 to make a class V modulating room thermostat (contribution 3%), boost function to activate a second source, proximity function, LED backlighting - 2 front modules.</p>
	<p>32042.x: XT By-me home automation system control device, thermostat function for room temperature control (heating and air-conditioning), 2- and 4-pipe system management, 3-speed and proportional fan coil control, class I temperature control device (contribution 1%) in ON/OFF mode, class IV (contribution 2%) in PID mode, can be interfaced with actuator with proportional analogue outputs 01466.1 to create a class V modulating room thermostat (contribution 3%), humidistat function with ON/OFF control with respect to a set parameter, VOC (volatile organic compound) function with ON/OFF control or to call up 2 scenarios, 2 push button function with configuration as 1 rocker button with status identification LED, central LED matrix to customise symbols or animation, proximity function, white LED backlighting - 2 front modules.</p>
	<p>32044.x: XT control device for By-me home automation system with 4 push buttons with backlighting CLIMATE CONTROL symbols and visible in darkness with brightness control - 1 front module.</p>

11.3 Functional units and parameters of XT actuator art. 32002

Description of functional units

ACTUATOR

- **Actuator:** To manage a lights actuator.
This functional unit receives the following control requests: load on/off, timed load on.
- **Timed actuator:** Also for the timed management of a lights actuator.
It receives the following control requests: double function of timed load on and/or load on/off.

ROLLER SHUTTER ACTUATOR

- **Roller shutter actuator:** To manage the roller shutter.
- **Slat:** To manage the roller shutter with slat

These functional units receive the following control requests:

- roller shutter opening/closing;
- rotation of slats;
- slat rotation and roller shutter height value setting;
- forcing of logic unit.

11.3.1 Configuration of the XT actuator art. 32002

The device is fitted with two relays which can be used individually to control two separate loads or, as a pair, to control a roller shutter actuator.

11.3.2 Parameters of the XT actuator art. 32002

ACTUATOR AND TIMED ACTUATOR

- **On delay and off delay:** they are delay times that can be set for actuating the On and Off request (from 0 s to 12 h with default value 0 s).
- **On time duration for one-position stable operation:** this is the activation time for one-position stable operation (from 1 s to 12 h with default value 30 s).
- **Warning time:** this is a time that is added to the activation time of the one-position stable actuator. At the end of the activation time the relay switches off for 0.5 s and then switches back on for the warning time (from 0 s to 12 h with default value 0 s).

XT platform devices

- **Output status at power-on:** allows you to set the status of the actuator when power is restored (ON/OFF/Unchanged with default value "Unchanged").
- **Operation:** used to set the operation of the actuator as either one-position stable or two-position stable (default value "two-position stable"). This parameter is only present for the TIMED ACTUATOR functional unit.
- **Status on standby of relay contact:** normally open (default value) or normally closed.

ROLLER SHUTTER AND SLAT ACTUATOR

- **Rise and fall time:** these are the roller shutter raising and lowering times (from 10 s to 1 h with default value 180 s).
- **Full slat rotation time:** from 500 ms to 5 s with default value 2 s.
- **Behaviour at power-on:** allows you to set whether when power is restored the roller shutter opens, closes, remains in the current position or you can choose the height of the roller shutter and the tilt of the slats): all down, all up, no action, default position. Default value "no action").
- **Roller shutter position at power-on:** allows you to set the position of the roller shutter when power is restored (from 0 to 100% with default value 50%).
- **Tilt of slats at power-on:** allows you to set the position of the slat when power is restored (from 0 to 100% with default value 50%).
- **Control execution delay:** from 0 s to 250 s with default value 0 s.
- **Position on forcing:** allows you to set the behaviour of the roller shutter upon the forcing request (all down, all up, fixed, preset position with default value "fixed"). It is necessary to observe the value set by the "roller shutter position on forcing" and "slat tilt on forcing" parameters.
- **Position on end of forcing:** allows you to set the behaviour of the roller shutter at the end of forcing (all down, all up, fixed, preset position with default value "fixed"). It is necessary to observe the value set by the "roller shutter position on forcing" and "slat tilt on forcing" parameters; it returns to the value prior to the request for forcing.
- **Roller shutter position on forcing:** it can be used in the "position on forcing" and "position on end of forcing" parameters (from 0 to 100% with default value 50%).
- **Slat tilt on forcing:** it can be used in the "position on forcing" and "position on end of forcing" parameters (from 0 to 100% with default value 50%).

11.4 Functional units and parameters of XT controls art. 32021 and 32031.G

Description of functional units

PUSH BUTTON

- Push button
- Dimmer control
- Roller shutter control
- Timed only control
- Timed and ON/OFF control
- Scenario control: to call up a scenario.
- Sleep (control for sound system)
- Audio monitoring (control for sound system)
- Temperature control functions control (season, operating mode, fan speed, sensor displayed, °C/°F), with XT thermostat art. 32041

ROCKER

- Rocker button
- Dimmer control
- Roller shutter control
- Timed only control
- Timed and ON/OFF control
- Volume On/Off (volume control for sound system)
- Sleep (control for sound system)
- ch+/track+ (control for sound system)

LED MATRIX

- Signalling
- Alarm
- Scenario

PROXIMITY

This functional unit is designed to activate (wake-up) the device from external events.

11.4.1 Configuration of XT controls art. 32021 and 32031.G

The devices comprise two individual push buttons and a central matrix. These functional units can be used independently (configuring them in different applications) or they can be used as a rocker.

11.4.2 Parameters of XT controls art. 32021 and 32031.G

Device

- **Day Standby Brightness - Load ON:** sets the brightness value of the entire device during the day when the load controlled is on (off, low, medium, high). Default value high).
- **Day Standby Brightness - Load OFF:** sets the brightness value of the entire device during the day when the load controlled is off (off, low, medium, high). Default value low).
- **Night Standby Brightness - Load ON:** sets the brightness value of the entire device during the night when the load controlled is on (off, low, medium, high). Default value medium).

XT platform devices

- **Night Standby Brightness - Load OFF:** sets the brightness value of the entire device during the night when the load controlled is off (off, low, medium, high. Default value low).

- **Return to standby time:** sets the time after which the device returns to standby (10 s, 15 s, 20 s, 30 s, 45 s, 1 min, never. Default value 10 s).

Functional unit – Push button

- **Push button behaviour:** normal push button (ON when the button is pressed, OFF when it is released), reversed push button (OFF when pressed, ON when released), toggle on the rising edge, toggle on the falling edge, toggle on both edges, ON only, OFF only, no action (signalling only). Default value "Toggle on the rising edge".
- **Roller shutter push button operation:** allows you to choose whether the stop control will be sent to the roller shutter on release of a long press (normal, one-position stable which sends the stop on release of the push button. Default value "normal").
- **Long press time:** from 0.5 ms to 30 s with default value 0.5 s.
- **Short/long press behaviour:** normal or reversed with default value "normal". This parameter is useful in the case of actuators with a timed function to invert the two ON/OFF and timer controls.
- **Send proximity enabling:** it allows you to enable the sending of proximity data to other devices in the same application (enabled, disabled. Default value disabled).
- **Receive proximity enabling:** it allows you to enable the receipt of proximity data sent by other devices in the same application (enabled, disabled. Default value disabled).

Functional unit - Rocker switch

- **Rocker switch operation:** it allows you to choose the behaviour of the two push buttons.
 - Normal which sends ON when the upper push button is pressed and OFF when the lower push button is pressed regardless of the load status
 - Toggle which sends the opposite value to the load status both when the upper push button and when the lower push button are pressed; this parameter does not apply to long presses and to the roller shutter configurations. Default value "toggle".
- **Roller shutter rocker switch operation:** allows you to choose whether the stop control will be sent to the roller shutter on release of a long press (normal, or one-position stable which sends the stop on release of the rocker switch. Default value "normal").
- **Long press time:** from 0.5 ms to 30 s with default value 0.5 s.
- **Short/long press behaviour:** normal or reversed with default value "normal". This parameter is useful in the case of actuators with a timed function to invert the two ON/OFF and timer controls.
- **Send proximity enabling:** it allows you to enable the sending of proximity data to other devices in the same application (enabled, disabled. Default value disabled).
- **Receive proximity enabling:** it allows you to enable the receipt of proximity data sent by other devices in the same application (enabled, disabled. Default value disabled).

Further parameters are present for XT control art. 32021 only:

- **Central LED matrix image:** it allows you to set what is displayed in the central LED matrix.
 - Disabled;
 - Static images (choosing one of the symbols in the library);
 - Percentage status of the controlled load (only in the case of dimmers, roller shutters and sound systems).
- **Animation on long pressing of upper button:** it allows you to set the animation of the central LED matrix during the control of the actuator with the upper button. It only applies in the case of dimmers/sound systems/roller shutters with a value chosen from the library of animations.
- **Animation on long pressing of lower button:** it allows you to set the animation of the central LED matrix during the control of the actuator with the lower button. It only applies in the case of dimmers/sound systems/roller shutters with a value chosen from the library of animations.

Functional Unit - LED matrix

- **Receive proximity enabling:** it allows you to enable the receipt of proximity data sent by other devices in the same application (enabled, disabled. Default value disabled).
- **Flashing speed** (only applicable in the case of configuration with alarm): low, high. Default value "low"
- **Only in the case of "Scenario" configuration, the following parameters replace those present at device level:**
 - **Day Standby Brightness - Load ON:** sets the brightness value of the central matrix during the day immediately after a scenario has been called up (off, low, medium, high. Default value low).
 - **Day Standby Brightness - Load OFF:** sets the brightness value of the central matrix during the day on standby (off, low, medium, high. Default value high).
 - **Night Standby Brightness - Load ON:** sets the brightness value of the central matrix during the night immediately after a scenario has been called up (off, low, medium, high. Default value low).
 - **Night Standby Brightness - Load OFF:** sets the brightness value of the central matrix during the night on standby (off, low, medium, high. Default value high).

A further parameter is present for XT control art. 32021 only:

LED matrix image: it allows you to set the symbol displayed in the central LED matrix, choosing between disabled or a static image (choosing one of the symbols in the library).

Functional unit - Proximity

Trigger value: it indicates at which values received the functional unit needs to wake-up the device (at ON value, at OFF value, at both. Default value "at both").

11.5 Functional units and parameters of XT advanced controls art. 32023 and 32033.G

Description of functional units

PUSH BUTTON

- Push button
- Dimmer control
- Roller shutter control
- Timed only control
- Timed and ON/OFF control
- Scenario control: to call up a scenario.
- Sleep (control for sound system)
- Audio monitoring (control for sound system)
- Temperature control functions control (season, operating mode, fan speed, sensor displayed, °C/°F), with XT thermostat art. 32041

ROCKER

- Rocker button
- Dimmer control
- Roller shutter control
- Timed only control
- Timed and ON/OFF control
- Volume On/Off (volume control for sound system)
- Sleep (control for sound system)
- ch+/track+ (control for sound system)

LED MATRIX

- Signalling
- Alarm
- Scenario

PROXIMITY

This functional unit is designed to activate (wake-up) the device from external events.

11.5.1 Configuration of XT advanced controls art. 32023 and 32033.G

The devices comprise two individual push buttons and a central matrix. These functional units can be used independently (configuring them in different applications) or they can be used as a rocker.

11.5.2 Parameters of XT advanced controls art. 32023 and 32033.G

Device

- **Day Standby Brightness - Load ON:** sets the brightness value of the entire device during the day when the load controlled is on (off, low, medium, high. Default value high).
- **Day Standby Brightness - Load OFF:** sets the brightness value of the entire device during the day when the load controlled is off (off, low, medium, high. Default value low).
- **Night Standby Brightness - Load ON:** sets the brightness value of the entire device during the night when the load controlled is on (off, low, medium, high. Default value medium).
- **Night Standby Brightness - Load OFF:** sets the brightness value of the entire device during the night when the load controlled is off (off, low, medium, high. Default value low).
- **Return to standby time:** sets the time after which the device returns to standby (10 s, 15 s, 20 s, 30 s, 45 s, 1 min, never. Default value 10 s).
- **Proximity sensitivity:** it sets the sensitivity of presence detection (Disabled, Low, Medium High. Default value "Low").

Functional unit – Push button

- **Push button behaviour:** normal push button (ON when the button is pressed, OFF when it is released), reversed push button (OFF when pressed, ON when released), toggle on the rising edge, toggle on the falling edge, toggle on both edges, ON only, OFF only, no action (signalling only). Default value "Toggle on the rising edge".
- **Roller shutter push button operation:** allows you to choose whether the stop control will be sent to the roller shutter on release of a long press (normal, one-position stable which sends the stop on release of the push button. Default value "normal").
- **Long press time:** from 0.5 ms to 30 s with default value 0.5 s.
- **Short/long press behaviour:** normal or reversed with default value "normal". This parameter is useful in the case of actuators with a timed function to invert the two ON/OFF and timer controls.
- **Send proximity enabling:** it allows you to enable the sending of proximity data to other devices in the same application (enabled, disabled. Default value disabled).
- **Receive proximity enabling:** it allows you to enable the receipt of proximity data sent by other devices in the same application (enabled, disabled. Default value disabled).

A further parameter is present for XT advanced control art. 32023 only:

LED matrix image: it allows you to set the symbol displayed in the central LED matrix, choosing between disabled or a static image (choosing one of the symbols in the library).

XT platform devices

Only in the case of configuration as scenario activator the following parameter is present:

LED matrix animation: it allows you to set an animation displayed in the LED matrix associated with the push button when it is pressed (disabled or animation chosen from one of the animations in the library).

Functional unit - Rocker switch

- **Rocker switch operation:** it allows you to choose the behaviour of the two push buttons.
 - Normal which sends ON when the upper push button is pressed and OFF when the lower push button is pressed regardless of the load status
 - Toggle which sends the opposite value to the load status both when the upper push button and when the lower push button are pressed; this parameter does not apply to long presses and to the roller shutter configurations (Default value "toggle").
- **Roller shutter rocker switch operation:** allows you to choose whether the stop control will be sent to the roller shutter on release of a long press (normal, or one-position stable which sends the stop on release of the rocker switch. Default value "normal").
- **Long press time:** from 0.5 ms to 30 s with default value 0.5 s.
- **Short/long press behaviour:** normal or reversed with default value "normal". This parameter is useful in the case of actuators with a timed function to invert the two ON/OFF and timer controls.
- **Send proximity enabling:** it allows you to enable the sending of proximity data to other devices in the same application (enabled, disabled. Default value disabled).
- **Receive proximity enabling:** it allows you to enable the receipt of proximity data sent by other devices in the same application (enabled, disabled. Default value disabled).

Further parameters are present for XT advanced control art. 32023 only:

Upper button LED matrix image: it allows you to set the symbol displayed in the LED matrix associated with the upper button, choosing between disabled or a static image (choosing one of the symbols in the library).

- **Central LED matrix image:** it allows you to set what is displayed in the central LED matrix.
 - Disabled;
 - Static images (choosing one of the symbols in the library);
 - Percentage status of the controlled load (only in the case of dimmers, roller shutters and sound systems).
- **Animation on long pressing of upper button:** it allows you to set the animation of the central LED matrix during the control of the actuator with the upper button. It only applies in the case of dimmers/sound systems/roller shutters with a value chosen from the library of animations.
- **Animation on long pressing of lower button:** it allows you to set the animation of the central LED matrix during the control of the actuator with the lower button. It only applies in the case of dimmers/sound systems/roller shutters with a value chosen from the library of animations.

Lower button LED matrix image: it allows you to set the symbol displayed in the LED matrix associated with the lower button, choosing between disabled or a static image (choosing one of the symbols in the library).

Functional Unit - LED matrix

- **Receive proximity enabling:** it allows you to enable the receipt of proximity data sent by other devices in the same application (enabled, disabled. Default value disabled).
- **Flashing speed** (only applicable in the case of configuration with alarm): low, high. Default value "low"
- **Only in the case of "Scenario" configuration, the following parameters replace those present at device level:**
 - **Day Standby Brightness - Load ON:** sets the brightness value of the central matrix during the day immediately after a scenario has been called up (off, low, medium, high. Default value low).
 - **Day Standby Brightness - Load OFF:** sets the brightness value of the central matrix during the day on standby (off, low, medium, high. Default value high).
 - **Night Standby Brightness - Load ON:** sets the brightness value of the central matrix during the night immediately after a scenario has been called up (off, low, medium, high. Default value low).
 - **Night Standby Brightness - Load OFF:** sets the brightness value of the central matrix during the night on standby (off, low, medium, high. Default value high).

A further parameter is present for XT advanced control art. 32023 only:

LED matrix image: it allows you to set the symbol displayed in the central LED matrix, choosing between disabled or a static image (choosing one of the symbols in the library).

Functional unit - Proximity

- **Trigger value:** it indicates at which values received the functional unit needs to wake-up the device (at ON value, at OFF value, at both. Default value "at both").

11.6 Functional units and parameters of XT controls art. 32024 and 32034.G

Description of functional units

PUSH BUTTON

- Push button
- Dimmer control
- Roller shutter control
- Timed only control
- Timed and ON/OFF control
- Scenario control: to call up a scenario.
- Sleep (control for sound system)
- Audio monitoring (control for sound system)
- Temperature control functions control (season, operating mode, fan speed, sensor displayed, °C/°F), with XT thermostat art. 32041

PROXIMITY

This functional unit is designed to activate (wake-up) the device from external events.

11.6.1 Configuration of XT controls art. 32024 and 32034.G

The devices comprise four individual push buttons which can be used independently.

11.6.2 Parameters of XT controls art. 32024 and 32034.G

Device

- **Day Standby Brightness - Load ON:** sets the brightness value of the entire device during the day when the load controlled is on (off, low, medium, high. Default value high).
- **Day Standby Brightness - Load OFF:** sets the brightness value of the entire device during the day when the load controlled is off (off, low, medium, high. Default value low).
- **Night Standby Brightness - Load ON:** sets the brightness value of the entire device during the night when the load controlled is on (off, low, medium, high. Default value medium).
- **Night Standby Brightness - Load OFF:** sets the brightness value of the entire device during the night when the load controlled is off (off, low, medium, high. Default value low).
- **Return to standby time:** sets the time after which the device returns to standby (10 s, 15 s, 20 s, 30 s, 45 s, 1 min, never. Default value 10 s).
- **Proximity sensitivity:** it sets the sensitivity of presence detection (Disabled, Low, Medium High. Default value "Low").

Functional unit – Push button

- **Push button behaviour:** normal push button (ON when the button is pressed, OFF when it is released), reversed push button (OFF when pressed, ON when released), toggle on the rising edge, toggle on the falling edge, toggle on both edges, ON only, OFF only, no action (signalling only). Default value "Toggle on the rising edge".
- **Roller shutter push button operation:** allows you to choose whether the stop control will be sent to the roller shutter on release of a long press (normal, one-position stable which sends the stop on release of the push button. Default value "normal").
- **Long press time:** from 0.5 ms to 30 s with default value 0.5 s.
- **Short/long press behaviour:** normal or reversed with default value "normal". This parameter is useful in the case of actuators with a timed function to invert the two ON/OFF and timer controls.
- **Send proximity enabling:** it allows you to enable the sending of proximity data to other devices in the same application (enabled, disabled. Default value disabled).
- **Receive proximity enabling:** it allows you to enable the receipt of proximity data sent by other devices in the same application (enabled, disabled. Default value disabled).

Functional unit - Proximity

- **Trigger value:** it indicates at which values received the functional unit needs to wake-up the device (at ON value, at OFF value, at both. Default value "at both").

XT platform devices

11.7 Functional units and parameters of the XT control art. 32044.x

Description of functional units

PUSH BUTTON

- Push button
- Dimmer control
- Roller shutter control
- Timed only control
- Timed and ON/OFF control
- Scenario control: to call up a scenario.
- Sleep (control for sound system)
- Audio monitoring (control for sound system)
- Temperature control functions control (season, operating mode, fan speed, sensor displayed, °C/°F), with XT thermostat art. 32041

PROXIMITY

This functional unit is designed to activate (wake-up) the device from external events.

11.7.1 Configuration of the XT control art. 32044.x

The devices comprise four individual push buttons which can be used independently.

11.7.2 Parameters of the XT control art. 32044.x

Device

- **Day Standby Brightness - Load ON:** sets the brightness value of the entire device during the day when the load controlled is on (off, low, medium, high. Default value high).
- **Day Standby Brightness - Load OFF:** sets the brightness value of the entire device during the day when the load controlled is off (off, low, medium, high. Default value low).
- **Night Standby Brightness - Load ON:** sets the brightness value of the entire device during the night when the load controlled is on (off, low, medium, high. Default value medium).
- **Night Standby Brightness - Load OFF:** sets the brightness value of the entire device during the night when the load controlled is off (off, low, medium, high. Default value low).
- **Return to standby time:** sets the time after which the device returns to standby (10 s, 15 s, 20 s, 30 s, 45 s, 1 min, never. Default value 10 s).

Functional unit – Push button

- **Push button behaviour:** normal push button (ON when the button is pressed, OFF when it is released), reversed push button (OFF when pressed, ON when released), toggle on the rising edge, toggle on the falling edge, toggle on both edges, ON only, OFF only, no action (signalling only). Default value "Toggle on the rising edge".
- **Roller shutter push button operation:** allows you to choose whether the stop control will be sent to the roller shutter on release of a long press (normal, one-position stable which sends the stop on release of the push button. Default value "normal").
- **Long press time:** from 0.5 ms to 30 s with default value 0.5 s.
- **Short/long press behaviour:** normal or reversed with default value "normal". This parameter is useful in the case of actuators with a timed function to invert the two ON/OFF and timer controls.
- **Send proximity enabling:** it allows you to enable the sending of proximity data to other devices in the same application (enabled, disabled. Default value disabled).
- **Receive proximity enabling:** it allows you to enable the receipt of proximity data sent by other devices in the same application (enabled, disabled. Default value disabled).

Functional unit - Proximity

- **Trigger value:** it indicates at which values received the functional unit needs to wake-up the device (at ON value, at OFF value, at both. Default value "at both").

11.8 Functional units and parameters of the XT thermostat art. 32041.x

The device comprises a series of functional units dedicated to temperature control functions.

It is also equipped with the following functional units:

- **Temperature from bus:** it allows you to receive a second temperature value.
- **Window open alarm:** it allows you to turn off the thermostat when a window is opened.
- **Shutdown alarm:** it allows you to shut down the thermostat in the event of an external alarm.
- **Proximity:** it allows you to wake-up the device from external events.

11.8.1 Parameters of the XT thermostat art. 32041.x

Device

- **Day Standby Brightness - Load ON:** sets the brightness value of the entire device during the day when the load controlled is on (off, low, medium, high). Default value high).
- **Day Standby Brightness - Load OFF:** sets the brightness value of the entire device during the day when the load controlled is off (off, low, medium, high). Default value low).
- **Night Standby Brightness - Load ON:** sets the brightness value of the entire device during the night when the load controlled is on (off, low, medium, high). Default value medium).
- **Night Standby Brightness - Load OFF:** sets the brightness value of the entire device during the night when the load controlled is off (off, low, medium, high). Default value low).
- **Return to standby time:** sets the time after which the device returns to standby (10 s, 15 s, 20 s, 30 s, 45 s, 1 min, never. Default value 10 s).
- **Proximity sensitivity:** it sets the sensitivity of presence detection (Disabled, Low, Medium High. Default value "Low").
- **Probe 1 calibration and probe 2 calibration:** Static calibration values relating to the internal probe (probe 1) and to the probe "from bus" (probe 2), respectively. This is an offset to which the temperature value read by the probe must be summed. These parameters are useful in all cases where there is an error with respect to a reference value (installation in a position that alters the correct reading, such as, for instance, a north-facing wall, proximity to the hot or cold water piping, etc.) but also to align two thermostats together, to align to a thermometer measurement, etc.

Functional unit - Thermostat

- **Operating mode ON:** Defines the type of operation (Automatic, Manual, Reduction) associating it with the ON control of the thermostat key.
- **Operating mode OFF:** Defines the type of operation (Absence, Protection, Off) associating it with the OFF control of the thermostat key.
- **Enables boost on auxiliary heat output:** Enables the boost function in heating and indicates whether the output marked as auxiliary must be used for the boost (+ mid season) or only for the mid season (Default value "On").
- **Aux.heat.threshold:** Difference from the setpoint for starting the boost function in heating mode; the function is switched off when the required temperature (setpoint) is reached, increased by the temperature differential.
- **Enable boost on auxiliary air conditioning output:** Enables the boost function in air conditioning and indicates whether the output marked as auxiliary must be used for the boost (+ mid season) or only for the mid season (Default value "On").
- **Aux.air-cond.threshold:** Difference from the setpoint for starting the boost function in air conditioning mode; the function is switched off when the required temperature (setpoint) is reached, decreased by the temperature differential.
- **Screed threshold:** Temperature value above which the screed limitation cuts in.
When this limitation is active, the thermostat will close its valve if the temperature measured by the Probe 2 (underfloor heating screed) exceeds the set threshold.
Caution: This is an extra action (and not for safety) that is added to the protection performed by the thermostatic valve prescribed by system regulations.
- **Use of Probe 2:** Sets the use of probe 2 (which is possibly the value received by the bus after the dedicated "Temperature from bus" functional unit has been configured); the settable values are the following:
 - Not present = Probe 2 not configured.
 - Temperature control (exclusive) = for temperature control, in place of Probe 1.
 - Temp. control (combined) = for temperature control, used as an average with Probe 1 (large rooms).
 - Screen Limit. = for screed limitation.
 - Display = display only (e.g: temperature in another room).
- **Neutral zone range:** Sets the range of the Neutral Zone centred on the related setpoint.
In the **Neutral Zone** adjustment mode, the thermostat automatically switches between heating and air conditioning according to the setpoint set, the temperature measured and considering any neutral zone around the setpoint defined by the **Neutral Zone Range** parameter (set from 1°C to 5°C in 1°C steps). For example, if the setpoint is set to 20°C and the neutral zone range is 2°C, the thermostat will switch the heating on if the temperature falls below 19°C (setpoint - neutral zone range/2) and will switch on the air conditioning if the temperature rises above 21°C (setpoint + neutral zone range/2). In this way a band of 2°C around which the thermostat neither heats or cools is defined (thus the name neutral zone).
Caution:
 - The "neutral zone" adjustment can of course be used only on 4-pipe systems (which can both heat and cool at the same time).
 - In the neutral zone adjustment mode, the thermostat only allows Manual and Off operating modes.
- **Heating setpoint adj.limit:** Defines the setpoint adjustment range limitation in heating mode; the following values can be set:
 - No limitation = the setpoint can be adjusted across all the available range.
 - Range 0 = the current setpoint can be modified by maximum +/- 0.5°C of the setpoint value saved in the memory.
 - Range 1 = as above but +/- 1°C.
 - Range 2 = as above but +/- 2°C.
 - Range 3 = as above but +/- 3°C.
 - Range 4 = as above but +/- 4°C.
 - Range 5 = as above but +/- 5°C.

XT platform devices

- **Air Conditioning setpoint adj.limit:** Defines the setpoint adjustment range limitation in air conditioning mode; the following values can be set:
 - No limitation = the setpoint can be adjusted across all the available range.
 - Range 0 = the current setpoint can be modified by maximum +/- 0.5°C of the setpoint value saved in the memory.
 - Range 1 = as above but +/- 1°C.
 - Range 2 = as above but +/- 2°C.
 - Range 3 = as above but +/- 3°C.
 - Range 4 = as above but +/- 4°C.
 - Range 5 = as above but +/- 5°C.
- **View:** Defines what to view in the main screen; the following values can be set:
 - Room temp. = room temperature (normal)
 - Current setpoint = setpoint temperature
 - Current setpoint delta.
 - Select "Current setpoint delta":
 - in the event of active setpoint adjustment limitations, the display shows the current setpoint delta compared to that locked in the limitation. Example: **Setpoint adj.limit** ➔ **Range 2**, the display will show the values from -2°C to +2°C
 - if there are no setpoint adjustment limitations, the display shows the setpoint value.
 - The "current setpoint delta" displayed is therefore used mainly in combination with **Setpoint adj. limit**.
- **Air conditioning Offset Calibration:** Offset to which the value of the temperature read by the Probe in Air conditioning must be summed. For probe 2 the calibration value is already applied in the functional unit of origin.
- **Heating Offset Calibration:** Offset to which the value of the temperature read by the Probe in Heating must be summed. For probe 2 the calibration value is already applied in the functional unit of origin.
- **Fan forcing:** Designed to control the fans irrespective of the valve state.
- **Restart after shutdown:** Defines the behaviour of the thermostat following a restart after shutdown.
- **Value transmission:** Indicates how to force the transmission of a temperature message.
- **Transmission interval:** Indicates the difference in time between 2 values read to generate a temperature message transmission. Designed to set the period of updating the temperature value on the supervisor devices (touch screens, etc.).
- **Keypad lock:** Enables the keypad lock (disables the keys).

Output functional unit

- **Control algorithm:** Defines the algorithm for the room temperature to match that of the setpoint set; the options are the following:
 - On/Off = This is the traditional "threshold" control so that, on exceeding the set temperature increased by the temperature differential (vice versa for air conditioning), the heating is switched off to then be turned back on when the room temperature drops below the set temperature.
 - PID = This is an evolved algorithm that is able to keep the temperature in the environment more stable, increasing comfort; this algorithm switches the system on and off appropriately so there will be a gradual increase or decrease in the thermal (or refrigerating) power of the system itself. To fully exploit the performances, it must be appropriately calibrated according to the type of environment or heating system, by setting the related parameters.
- **Hysteresis:** Sets the hysteresis value to be used in the case of an on/off algorithm (can be set from 0.1°C to 1°C in 0.1°C steps)
- **PWM time:** Sets the length of a PWM cycle in the case of a PID algorithm for controlling on/off valves.

It therefore corresponds to the time in which a cycle of adjustment is completed; the shorter this time, the better the adjustment but the temperature control system is under greater stress. This parameter setting is thus the result of a compromise between the accuracy of the dimmer and the load on the system; in general, the rule is that T_b can be that much higher (and therefore put fewer demands on the system), the slower the system or the larger the environment to regulate.

Caution: The value must be much greater than the on and off times of the valves
- **Band (P):** Parameter used by the PID algorithm to calculate the coeff. $K_p = 100/B_p$.

Corresponds to the breadth of proportional adjustment range: starting from the set temperature, this value represents the temperature range in which the system power goes from 0% to 100%.

For example: with the (heating) temperature set to 20.0°C and Band (P) = 4.0°C, the thermostat runs the heating system at 100% when **room T.** is ≤ 16.0 °C; as this temperature increases, the system power is consequently lowered down to 0% when the room temperature reaches 20°C. The value must be set consistently with the thermal capacity of the environment controlled; in general, it is recommended to use small values for environments with a good level of thermal insulation and vice-versa.
- **Time (I):** Parameter used by the PID algorithm to calculate the coeff. $K_i = K_p/T_i$.

Corresponds to the time after which, when equal to the deviation from the setpoint (error), the additional component generates a contribution equal to that generated by the proportional component. The integral contribution is used to reduce the error on full operation if thermal energy is lost in the environment controlled, as this contribution increases according to the time during which the setpoint is not reached. If this value is not set perfectly, it can cause transients with oscillations around the setpoint or it may take longer to reach the setpoint.
- **Time (D):** Parameter used by the PID algorithm to calculate the coeff. $K_d = K_p * T_d$.

Corresponds to the time only the proportional action would take to generate a control signal equal to that produced by the derivative action. The derivative contribution opposes the system variations and has no role in eliminating the error but is used to stabilise the control operations, particularly in systems that are characterised by sudden variations. The derivative contribution must be enabled with care, particularly in systems with long dead times, as this could make the control chain unstable; generally the most appropriate algorithm in these cases corresponds to type PI (proportional-integral).
- **Speed control:** It is possible to select two different control modes:
 - Interlock: the thermostat sends a control message exclusively at a single speed: V1, V2 or V3
 - Step-step: the thermostat sends a message cumulatively: V1, V1+V2, V1+V2+V3

XT platform devices

- **Start delay:** It sets the delay time of the fan start.
This parameter is used only during the operating or adjustment mode change while it is not used during temperature control (for example if the thermostat switches off the output and then switches it back on)
- **Speed band:** It defines the thermal delta to run the fan coil fan at maximum speed.
The speed scale (in the case of an on/off algorithm) is defined in correspondence to the difference between the room temperature and the current Setpoint.

Input functional unit window contact from BUS

- **Reaction time:** Sets the reaction time if a window warning is received; in fact, it indicates after how much time the thermostat block should come on if a window is open. In the event that the reaction time is set to 0, the thermostat switches to window open status 10 s after the window has been opened.

Example:

When the window is closed the heating/air conditioning is on; if the window is opened the heating/air conditioning stays on for the time set in the **Reaction time**. If within that time interval the window is closed, the heating/air conditioning remains on.

- **Reactivation time:** Sets the reactivation time if a window warning is received; in fact, it indicates after how much time the thermostat shutdown should be removed due to an open window.

Example:

When the window is closed the heating/air conditioning is on; if the window is opened the heating/air conditioning turns off and remains so for the time set in the **Reaction time**. At the end of the time interval the heating/air conditioning comes back on whether or not the window has been closed.

- **Control input report:** Defines the behaviour of the alarm upon closing or opening of the input.

Input functional unit Block contact from BUS

- **Reaction time:** Sets the reaction time if an open contact signal is received; in fact, it indicates after how much time the thermostat shutdown should come on if a boiler shuts down. In the event that the reaction time is set to 0, the thermostat switches to boiler shutdown status 10 s after the contact has been opened.

Example:

When the contact is closed, the boiler is working properly; if the contact opens the thermostat stays on for an amount of time equal to **Reaction time**. If within that time interval the boiler resumes working, the thermostat remains on.

- **Reactivation time:** Sets the reactivation time if an open contact signal is received; in fact, it indicates after how much time the thermostat shutdown should be removed if a boiler shuts down.

Example:

When the contact is closed, the boiler is working properly; if the contact opens the thermostat is turned off and remains off for an amount of time equal to **Reactivation time**. At the end operation of the time interval the thermostat comes back on whether or not the boiler has resumed operation.

- **Control input report:** Defines the behaviour of the alarm upon closing or opening of the input.

Display functional unit

- **Default unit of measure:** Sets the unit of measure used by default to view the temperature on the display.
- **Enable monochrome mode:** If this option is enabled, the thermostat uses the white LEDs to signal the status of the active output. If the option is disabled, the thermostat uses the amber LED to signal heating activation and the blue LED to signal air conditioning activation
- **Send proximity enabling:** it allows you to enable the sending of proximity data to other devices in the same application (enabled, disabled. Default value disabled).
- **Receive proximity enabling:** It allows you to enable the receipt of proximity data sent by other devices in the same application (enabled, disabled. Default value disabled).
- **Upper button LED matrix image:** It allows you to set the symbol displayed in the LED matrix associated with the upper button ("⋮", "⋮"). Default value "⋮".
- **Lower button LED matrix image:** It allows you to set the symbol displayed in the LED matrix associated with the lower button ("⋮", "⋮"). Default value "⋮".

Functional unit - Proximity

- **Trigger value:** it indicates at which values received the functional unit needs to wake-up the device (at ON value, at OFF value, at both. Default value "at both").

11.9 Functional units and parameters of the XT Multisensor art. 32042.x

The device is integrated with the following four sensors:

- **Thermostat (T)**

The thermostat is integrated with the By-me home automation system for temperature control in 2- or 4-pipe systems (heating/air conditioning) and neutral zone (4-pipe systems only), with “boost” function to activate a second source that makes it possible to reach the desired thermal comfort faster. The thermostat is fitted with a white LED matrix display and 2 buttons to control the temperature setpoint and to turn the temperature control system on/off. Opposite each button are white LEDs for the “up and down arrow” or “+ and -” symbols. There are also two LEDs that indicate the heating phase (amber or configurable white LED) or cooling phase (blue or configurable white LED). During the configuration phase, you can choose whether to view the room temperature, the current setpoint or the current setpoint delta normally. The thermostat can be configured to integrate HVAC type split/VRV systems via third-party KNX interfaces.

- **Humidistat (H)**

The humidistat is integrated with the By-me Plus home automation system and allows the current humidity to be shown on the display or on the View App. It also allows the sending of an On/Off control on the bus when the humidity value increases or decreases with respect to a parameter set during the configuration phase. It can be used to manage ventilation and for dewpoint management, in combination with the temperature and VRV systems.

- **VOC sensor**

The VOC (volatile organic compounds) sensor is integrated with the By-me Plus home automation system and allows the air quality variations to be shown on the display or on the View App. It also allows the sending of an On/Off control or to call up 2 scenarios when the air quality worsens or improves with respect to parameters set during the configuration phase. The VOC sensor, in combination with temperature and humidity, makes it possible to manage ventilation to improve the quality of the air.

- **Proximity sensor**

The proximity sensor (the sensitivity of which can be set via the View Pro App) enables the multisensor activation by approaching a hand at a distance set during the configuration phase. Activation propagates the information to the other controls on the same electrified XT mounting frame. The time on standby is configurable.

The device can be used in the following ways:

- **Mode 1 - “Thermostat”:** Locally controlled thermostat for ON/OFF + setpoint adjustment, possibly with interface block function (as per parameter) without symbols on the keys. The symbols of the upper and lower keys can be customised, choosing from the library.

It allows:

- Viewing of temperature and setpoint on central display. If the climate control art. 32044.x is present, values T, H and VOC will be shown on the display (they will in any case always be displayed on the View App).
- Editing of the values: summer_winter/fan speed/Celsius_Fahrenheit/on_off using the external keys of the climate control.

- **Mode 2 - “Push button control/rocker switch with thermostat probe”:** Control with 2 push buttons or 1 rocker switch where the 2 keys can be configured as 2 push buttons or grouped together as 1 rocker switch + “By-me” thermostat controllable from the View App.

The symbols of the upper and lower keys can be customised. In the case of 1 rocker switch the central white LED matrix can be used for customised symbols or for animation, while in the case of 2 push buttons it can be used to display any alarms, load status and scenario activation with customised symbols. The values T, H and VOC are not shown on the display but only on the View App or on the touch screens.

- **Mode 3 - “Sensor viewer”:** Viewer of the values T, H and VOC on the display. It is used as a simple viewer and normally shows the current temperature. Using the two keys on the device (or with climate control art. 32044.x) the values of remote probe temperature, humidity, and air quality can be browsed and displayed.

- **Mode 4, “VRV systems control”:** Control of VRV systems via the KNX gateway.

The locally controlled thermostat for ON/OFF + setpoint adjustment, possibly with interface block function (as per parameter) without symbols on the keys. The symbols of the upper and lower keys can be customised, choosing from the library.

It allows:

- Viewing of temperature and setpoint on central display. If the climate control art. 32044.x is present, values T, H and VOC will be shown on the display (they will in any case always be displayed on the View App).
- Editing of the values: operating mode/fan speed/Celsius_Fahrenheit/on_off using the external keys of the climate control.

- **Mode 5, “Push button control/rocker switch with thermostat probe for split/VRV integration”:** Control with 2 push buttons or 1 rocker switch where the 2 keys can be configured as 2 push buttons or grouped together as 1 rocker switch + thermostat (split/VRV integration) controllable from the View App.

The symbols of the upper and lower keys can be customised. In the case of 1 rocker switch the central white LED matrix can be used for customised symbols or for animation, while in the case of 2 push buttons it can be used to display any alarms, load status and scenario activation with customised symbols. The values T, H and VOC are not shown on the display but only on the View App.

Functions available for each mode:

- Viewing of humidity/air quality/external temperature on the View App, IP touch screens and use for logics.
- Sending of ON/OFF controls when the humidity value measured increases/decreases with respect to a threshold configured with the View Pro App (sending of two controls in reference to two thresholds).
- Sending of ON/OFF control or activation of two scenarios when the air quality improves or worsens with respect to a threshold configured with the View Pro App.
- Wake-up of device upon external events (e.g. change in contact interface status, integration with By-alarm Plus, PIR sensors).

XT platform devices

Summary of Functions - Mode					
Function	Mode 1	Mode 2	Mode 3	Mode 4	Mode 5
	"Thermostat"	"Push button control/rocker switch with thermostat probe"	"Sensor viewer"	"VRV systems control"	"Push button control/rocker switch with thermostat probe for split/VRV integration"
By-me mode thermostat locally controllable (possibly with interface block function).	✓				
Integration mode thermostat (split/VRV) via third-party locally controllable KNX gateway (possibly with interface block function).				✓	
Thermostat management in By-me or integration mode (split/VRV) with View App and IP touch screen.	✓	✓		✓	✓
Temperature view (without temperature control logics).			✓		
Viewing of humidity/air quality/external temperature on the device display.	✓		✓	✓	
Viewing of humidity/air quality/external temperature on the View App, IP touch screens and use for logics.	✓	✓	✓	✓	✓
Sending of ON/OFF controls when the humidity measured increases/decreases with respect to a threshold configured with the View Pro App (up to two different thresholds).	✓	✓	✓	✓	✓
Sending of ON/OFF control or activation of two scenarios when the air quality improves or worsens with respect to a threshold configured with the View Pro App.	✓	✓	✓	✓	✓
Dewpoint management.	✓	✓		✓	✓
Window contact and/or boiler/heat pump contact management.	✓	✓		✓	✓
Use of the rocker switch to control lights/roller shutters/audio or Use of 2 push buttons to control lights/roller shutters/scenarios and central LED matrix to signal load status/alarms/scenario activation		✓			✓

The device comprises functional units dedicated to temperature control functions.

It is also equipped with the following functional units:

- **Temperature from bus:** it allows you to receive a second temperature value.
- **Delivery temperature from bus:** makes it possible to receive a temperature value to calculate the dewpoint (for instance floor/screed temperature with temperature sensor 02965.1 and home automation interface with 3 analogue inputs 01467).
- **Window open alarm:** it allows you to turn off the thermostat when a window is opened.
- **Shutdown alarm:** it allows you to shut down the thermostat in the event of an external alarm.
- **Backlighting Wake-up from Event:** it allows you to wake-up the device with external events.
- **Push buttons, Rocker switch, Central matrix:** allow the device to be used as a control.
- **Functional units for viewing the air quality and humidity.**
- **Functional units for the condition of the air quality and humidity to activate the related events.**
- **Temperature:** makes it possible to use the device as a temperature sensor instead of a thermostat.

11.9.1 Parameters of the XT Multisensor art. 32042.x

Device

- **Activated day standby function brightness :** sets the brightness value of the entire device during the day when the load controlled is on (off, low, medium, high. Default value high).
- **Deactivated day standby function brightness:** sets the brightness value of the entire device during the day when the load controlled is off (off, low, medium, high. Default value low).
- **Activated night standby function brightness:** sets the brightness value of the entire device during the night when the load controlled is on (off, low, medium, high. Default value medium).
- **Deactivated night standby function brightness:** sets the brightness value of the entire device during the night when the load controlled is off (off, low, medium, high. Default value low).
- **Return to standby time:** sets the time after which the device returns to standby (10 s, 15 s, 20 s, 30 s, 45 s, 1 min, never. Default value 10 s).
- **Proximity sensitivity:** it sets the sensitivity of presence detection (Disabled, Low, Medium High. Default value "Medium").

- **Probe 1 calibration, probe 2 calibration and delivery probe calibration:** Static calibration values relating to the internal probe (probe 1), the probe “from bus” (probe 2) and the probe “from bus used to calculate the dewpoint”, respectively. This is an offset to which the temperature value read by the probe must be summed. These parameters are useful in all cases where there is an error with respect to a reference value (installation in a position that alters the correct reading, such as, for instance, a north-facing wall, proximity to the hot or cold water piping, etc.) but also to align two thermostats together, to align to a thermometer measurement, etc.
- **Thermostat connection with humidity status:** enables the connection between the thermostat functional unit and the humidity status 1 and humidity status 2 functional units. When this parameter is active (default setting), if the thermostat is in By-me mode and in an ON operating mode (Auto, Manual, Timed manual and Reduction modes) or in integration mode (VRV) and ON the humidity functional units recall the events set. Instead when the thermostat is in an OFF mode, be it in By-me and integration mode, the humidity status functional units do not recall the events. In the event that the parameter is deactivated, the humidity status functional units always recall the events set regardless of the thermostat operating mode.
- **Thermostat connection with air quality status:** enables the connection between the thermostat functional unit and the air quality status functional units. When this parameter is active, if the thermostat is in By-me mode and in an ON operating mode (Auto, Manual, Timed manual and Reduction modes) or in integration mode (VRV) and ON the air quality status functional unit recalls the events set. Instead when the thermostat is in an OFF mode, be it in By-me and integration mode, the air quality status functional unit does not recall the events. In the event that the parameter is deactivated (default setting), the air quality status functional unit always recalls the events set regardless of the thermostat operating mode.

Functional unit - Thermostat

BY-ME MODE

- **Operating mode ON:** Defines the type of operation (Automatic, Manual, Reduction) associating it with the ON control of the thermostat key.
- **Operating mode OFF:** Defines the type of operation (Absence, Protection, Off) associating it with the OFF control of the thermostat key.
- **Enables boost on auxiliary heat output:** Enables the boost function in heating and indicates whether the output marked as auxiliary must be used for the boost (+ mid season) or only for the mid season (Default value “On”).
- **Aux.heat.threshold:** Difference from the setpoint for starting the boost function in heating mode; the function is switched off when the required temperature (setpoint) is reached, increased by the temperature differential.
- **Enable boost on auxiliary air conditioning output:** Enables the boost function in air conditioning and indicates whether the output marked as auxiliary must be used for the boost (+ mid season) or only for the mid season (Default value “On”).
- **Aux.air-cond.threshold:** Difference from the setpoint for starting the boost function in air conditioning mode; the function is switched off when the required temperature (setpoint) is reached, decreased by the temperature differential.
- **Screed threshold:** Temperature value above which the screed limitation cuts in.
When this limitation is active, the thermostat deactivates the output if the temperature measured by the Probe 2 (underfloor heating screed) exceeds the set threshold.
Caution: This is an extra action (and not for safety) that is added to the protection performed by the thermostatic valve prescribed by system regulations (in the case of a system with water).
- **Use of Probe 2:** Sets the use of probe 2 (which is possibly the value received by the bus after the dedicated “Temperature from bus” functional unit has been configured); the settable values are the following:
 - Not present = Probe 2 not configured.
 - Temperature control (exclusive) = for temperature control, in place of Probe 1.
 - Temp. control (combined) = for temperature control, used as an average with Probe 1 (large rooms).
 - Screen Limit. = for screed limitation.
 - View = view only (e.g: temperature in another room).
- **Neutral zone range:** Sets the range of the Neutral Zone centred on the related setpoint.
In the **Neutral Zone** adjustment mode, the thermostat automatically switches between heating and cooling according to the set set-point, the temperature measured and considering any neutral zone around the set point defined by the **Neutral Zone Range** parameter (set from 1°C to 5°C in 1°C steps).
For example, if the setpoint is set to 20°C and the neutral zone range is 2°C, the thermostat will switch the heating on if the temperature falls below 19°C (setpoint – neutral zone range/2) and will switch on the air conditioning if the temperature rises above 21°C (setpoint + neutral zone range/2). In this way a band of 2°C around which the thermostat neither heats or cools is defined (thus the name neutral zone).
Caution:
 - The “neutral zone” adjustment can of course be used only on 4-pipe systems (which can both heat and cool at the same time).
 - In the neutral zone adjustment mode, the thermostat only allows Manual and Off operating modes.
- **Heating setpoint adj.limit:** Defines the setpoint adjustment range limitation in heating mode; the following values can be set:
 - No limitation = the setpoint can be adjusted across all the available range.
 - Range 0 = the current setpoint can be modified by maximum +/- 0.5°C of the setpoint value saved in the memory.
 - Range 1 = as above but +/- 1°C.
 - Range 2 = as above but +/- 2°C.
 - Range 3 = as above but +/- 3°C.
- **Air Conditioning setpoint adj.limit:** Defines the setpoint adjustment range limitation in air conditioning mode; the following values can be set:
 - No limitation = the setpoint can be adjusted across all the available range.
 - Range 0 = the current setpoint can be modified by maximum +/- 0.5°C of the setpoint value saved in the memory.
 - Range 1 = as above but +/- 1°C.
 - Range 2 = as above but +/- 2°C.
 - Range 3 = as above but +/- 3°C.
 - Range 4 = as above but +/- 4°C.
 - Range 5 = as above but +/- 5°C.

XT platform devices

- **View:** Defines what to view in the main screen; the following values can be set:
 - Room temp. = room temperature (normal)
 - Current setpoint = setpoint temperature
 - Current setpoint delta.
 - Select "Current setpoint delta":
 - in the event of active setpoint adjustment limitations, the display shows the current setpoint delta compared to that locked in the limitation. Example: **Setpoint adj. limit.** ➔ **Range 2**, the display will show the values from -2°C to +2°C
 - if there are no setpoint adjustment limitations, the display shows the setpoint value.
- **Air conditioning Offset Calibration:** Offset to which the value of the temperature read by the Probe in Air conditioning must be summed. For probe 2 the calibration value is already applied in the functional unit of origin.
- **Heating Offset Calibration:** Offset to which the value of the temperature read by the Probe in Heating must be summed. For probe 2 the calibration value is already applied in the functional unit of origin.
- **Fan forcing:** Designed to control the fans irrespective of the valve state.
- **Restart after shutdown:** Defines the behaviour of the thermostat following a restart after shutdown.
- **Value transmission:** Indicates how to force the transmission of a temperature message.
- **Transmission interval:** Indicates the time difference between 2 values read to generate a temperature message transmission. Designed to set the period of updating the temperature value on the supervisor devices (touch screens, etc.).
- **Keypad lock:** Enables the keypad lock (disables the keys).
- **Dewpoint calculation:** Enables the mechanism to switch off the thermostat because of the dewpoint (condensation formation). The humidity functional unit is required to be configured in a Sensor application.
- **Fixed delivery temperature:** Provides the thermostat with a fixed delivery temperature value to be used in the dewpoint calculation (where enabled). This parameter intervenes in the event that the functional unit for bus reception of the value is not configured.

INTEGRATION MODE (SPLIT & VRV)

- **Screed threshold:** Temperature value above which the screed limitation cuts in.
 - When this limitation is in effect, the thermostat will close its valve if the temperature measured by the Probe 2 (underfloor heating screed) exceeds the set threshold.
 - Caution:** This is an extra action (and not for safety) that is added to the protection performed by the thermostatic valve prescribed by system regulations.
- **Use of Probe 2:** Sets the use of probe 2 (which is possibly the value received by the bus after the dedicated "Thermostat Probe 2 Input from BUS" functional unit has been configured"; the settable values are the following:
 - Not present = Probe 2 not configured.
 - Temperature control (exclusive) = for temperature control, in place of Probe 1.
 - Temp. control (combined) = for temperature control, used as an average with Probe 1 (large rooms).
 - Screen Limit. = for screed limitation.
 - View = view only (e.g. temperature in another room).
- **Setpoint adj. limit.:** Defines the setpoint adjustment range limitation, the following values can be set:
 - No limitation = the setpoint can be adjusted across all the available range.
 - Range 0 = the current setpoint can be modified by maximum +/- 0.5°C of the setpoint value saved in the memory.
 - Range 1 = as above but +/- 1°C.
 - Range 2 = as above but +/- 2°C.
 - Range 3 = as above but +/- 3°C.
 - Range 4 = as above but +/- 4°C.
 - Range 5 = as above but +/- 5°C.
- **View:** Defines what to view in the main screen; the following values can be set:
 - Room temp. = room temperature (normal)
 - Current setpoint = setpoint temperature
 - Current setpoint delta.
 - Select "Current setpoint delta":
 - in the event of active setpoint adjustment limitations, the display shows the current setpoint delta compared to that locked in the limitation. Example: **Setpoint adj. limit.** ➔ **Range 2**, the display will show the values from -2°C to +2°C
 - if there are no setpoint adjustment limitations, the display shows the setpoint value.
- **Restart after shutdown:** Defines the behaviour of the thermostat following a restart after shutdown.
- **Value transmission:** Indicates how to force the transmission of a temperature message.
- **Transmission interval:** Indicates the difference in time between 2 values read to generate a temperature message transmission. Designed to set the period of updating the temperature value on the supervisor devices (touch screens, etc.).
- **Keypad lock:** Enables the keypad lock (disables the keys).
- **Dewpoint calculation:** Enables the mechanism to switch off the thermostat because of the dewpoint (condensation formation). The humidity functional unit is required to be configured in a Sensor application.
- **Fixed delivery temperature:** Provides the thermostat with a fixed delivery temperature value to be used in the dewpoint calculation (where enabled). This parameter intervenes in the event that the functional unit for bus reception of the value is not configured.

- **Enable Automatic mode, Enable Heating mode, Enable Air conditioning mode, Enable Ventilation mode and Enable Dehumidification mode:** Enables the management of the respective operating mode. At least one mode must be active.
- **Setpoint Step Resolution (supervision):** Defines the increase/decrease step in the setpoint value from the supervisors.
- **Setpoint Step Resolution (device):** Defines the increase/decrease step in the setpoint value by physically pressing on the device.
- **Setpoint Range Minimum and Setpoint Range Maximum:** Define the range of values the setpoint can assume
- **Automatic/Manual fan mode value inversion:** Enables the inversion of the value sent on the bus for the manual fan mode:
 - Off = value 0 means Manual, 1 means Automatic
 - On = value 1 means Manual, 0 means Automatic
- **Fan management mode:** Indicates the presence of fans and, if they are present, their management mode from the perspective of bus messages:
 - Not present = fans not configured
 - Scaling = fans present with type 5.001 datapoints
 - Enum = fans present and managed with type 5.010 datapoints
 - Bits = fans present and managed with type 1.001 datapoints
- **Fan speed number:** Indicates the fan speed number configured (from 2 to 5)
- **Fan speed threshold:** This parameter only applies if the fan management "Scaling" mode is selected. Each parameter indicates which threshold value should be considered for the related speed interval (indicated in the name of the parameter itself).

Notes:

 - "N-1" parameters are always considered (where N is the speed number configured in the related parameter) since the last speed always has the threshold of 100%.
 - to operate correctly, the fan speed thresholds need to have an increasing value starting from threshold 1 up to threshold N-1.
- **Fan speed value:** This parameter only applies if the fan management "Enum" mode is selected. Each parameter indicates which value is interpreted for the related speed interval (indicated in the name of the parameter itself).

N.B.: "N" parameters are always considered (where N is the speed number configured in the related parameter).

Output functional unit

- **Control algorithm:** Defines the algorithm for the room temperature to match that of the setpoint set; the options are the following:
 - On/Off = This is the traditional "threshold" control so that, on exceeding the set temperature increased by the temperature differential (vice versa for air conditioning), the heating is switched off to then be turned back on when the room temperature drops below the set temperature.
 - PID = This is an evolved algorithm that is able to keep the temperature in the environment more stable, increasing comfort; this algorithm switches the system on and off appropriately so there will be a gradual increase or decrease in the thermal (or refrigerating) power of the system itself. To fully exploit the performances, it must be appropriately calibrated according to the type of environment or heating system, by setting the related parameters.
- **Hysteresis:** Sets the hysteresis value to be used in the case of an on/off algorithm (can be set from 0.1°C to 1°C in 0.1°C steps)
- **PWM time:** Sets the length of a PWM cycle in the case of a PID algorithm for controlling on/off valves.

It therefore corresponds to the time in which a cycle of adjustment is completed; the shorter this time, the better the adjustment but the temperature control system is under greater stress. This parameter setting is thus the result of a compromise between the accuracy of the dimmer and the load on the system; in general, the rule is that T_b can be that much higher (and therefore put fewer demands on the system), the slower the system or the larger the environment to regulate.

Caution: The value must be much greater than the on and off times of the valves
- **Band (P):** Parameter used by the PID algorithm to calculate the coeff. $K_p = 100/B_p$.

Corresponds to the breadth of proportional adjustment range: starting from the set temperature, this value represents the temperature range in which the system power goes from 0% to 100%.

For example: with the (heating) temperature, set to 20.0°C and Band (P) =4.0°C, the thermostat runs the heating system at 100% when **room T.** is ≤ 16.0 °C; as this temperature increases, the system power is consequently lowered down to 0% when the room temperature reaches 20°C. The value must be set consistently with the thermal capacity of the environment controlled; in general, it is recommended to use small values for environments with a good level of thermal insulation and vice-versa.
- **Time (I):** Parameter used by the PID algorithm to calculate the coeff. $K_i = K_p/T_i$.

Corresponds to the time after which, when equal to the deviation from the setpoint (error), the additional component generates a contribution equal to that generated by the proportional component. The integral contribution is used to reduce the error on full operation if thermal energy is lost in the environment controlled, as this contribution increases according to the time during which the setpoint is not reached. If this value is not set perfectly, it can cause transients with oscillations around the setpoint or it may take longer to reach the setpoint.
- **Time (D):** Parameter used by the PID algorithm to calculate the coeff. $K_d = K_p * T_d$.

Corresponds to the time only the proportional action would take to generate a control signal equal to that produced by the derivative action. The derivative contribution opposes the system variations and has no role in eliminating the error but is used to stabilise the control operations, particularly in systems that are characterised by sudden variations. The derivative contribution must be enabled with care, particularly in systems with long dead times, as this could make the control chain unstable; generally the most appropriate algorithm in these cases corresponds to type PI (proportional-integral).
- **Speed control:** It is possible to select two different control modes:
 - Interlock: the thermostat sends a control message exclusively at a single speed: V1, V2 or V3
 - Step-step: the thermostat sends a message cumulatively: V1, V1+V2, V1+V2+V3
- **Start delay:** It sets the delay time of the fan start.

This parameter is used only during the operating or adjustment mode change while it is not used during temperature control (for example if the thermostat switches off the output and then switches it back on)
- **Speed band:** It defines the thermal delta to run the fan coil fan at maximum speed.

The speed scale (in the case of an on/off algorithm) is defined in correspondence to the difference between the room temperature and the current Setpoint.

Input functional unit window contact from BUS

- **Reaction time:** Sets the reaction time if a window warning is received; in fact, it indicates after how much time the thermostat block should come on if a window is open. In the event that the reaction time is set to 0, the thermostat switches to window open status 10 s after the window has been opened.

Example:

When the window is closed the heating/air conditioning is on; if the window is opened the heating/air conditioning stays on for the time set in the **Reaction time**. If within that time interval the window is closed, the heating/air conditioning remains on.

- **Reactivation time:** Sets the reactivation time if a window warning is received; in fact, it indicates after how much time the thermostat shutdown should be removed due to an open window.

Example:

When the window is closed the heating/air conditioning is on; if the window is opened the heating/air conditioning turns off and remains so for the time set in the **Reaction time**. At the end of the time interval the heating/air conditioning comes back on whether or not the window has been closed.

- **Control input report:** Defines the behaviour of the alarm upon closing or opening of the input.

Input functional unit Block contact from BUS

- **Reaction time:** Sets the reaction time if an open contact signal is received; in fact, it indicates after how much time the thermostat shutdown should come on if a boiler shuts down. In the event that the reaction time is set to 0, the thermostat switches to boiler shutdown status 10 s after the contact has been opened.

Example:

When the contact is closed, the boiler is working properly; if the contact opens the thermostat stays on for an amount of time equal to **Reaction time**. If within that time interval the boiler resumes working, the thermostat remains on.







- **Reactivation time:** Sets the reactivation time if an open contact signal is received; in fact, it indicates after how much time the thermostat shutdown should be removed if a boiler shuts down.

Example:

When the contact is closed, the boiler is working properly; if the contact opens the thermostat is turned off and remains off for an amount of time equal to **Reactivation time**. At the end operation of the time interval the thermostat comes back on whether or not the boiler has resumed operation.

- **Control input report:** Defines the behaviour of the alarm upon closing or opening of the input.

Display functional unit

- **Default unit of measure:** Sets the unit of measure used by default to view the temperature on the display.
- **Enable monochrome mode:** If this option is enabled, the thermostat uses the white LEDs to signal the status of the active output. If the option is disabled, the thermostat uses the amber LED to signal heating activation and the blue LED to signal air conditioning activation.
N.B. This parameter only applies when the display functional unit is configured at the same time as a thermostat in By-me mode since in the other configurations the related LEDs (both white and coloured) are not used.
- **Send backlighting wake-up on pressing control enabling:** it allows you to enable the sending of the wake-up data to other devices in the same application (enabled, disabled. Default value disabled).
- **Upper icon:** It allows you to set the symbol displayed in the LED matrix associated with the upper button (“”, “”. Default value “”).
- **Lower icon:** It allows you to set the symbol displayed in the LED matrix associated with the lower button (“”, “”. Default value “”).

Backlighting Wake-up from Event functional unit

- **Backlighting wake-up value:** it indicates at which values received the functional unit needs to wake-up the device (at ON value, at OFF value, at both. Default value “at both”).

Functional unit – Push button

- **Push button behaviour:** normal push button (ON when the button is pressed, OFF when it is released), reversed push button (OFF when pressed, ON when released), toggle on the rising edge, toggle on the falling edge, toggle on both edges, ON only, OFF only, no action (signalling only). Default value “Toggle on the rising edge”.
- **Roller shutter push button operation:** allows you to choose whether the stop control will be sent to the roller shutter on release of a long press (normal, one-position stable which sends the stop on release of the push button. Default value “normal”).
- **Long press time:** from 0.5 ms to 30 s with default value 0.5 s.
- **Short/long press behaviour:** normal or reversed with default value “normal”. This parameter is useful in the case of actuators with a timed function to invert the two ON/OFF and timer controls.
- **Send backlighting wake-up on pressing control enabling:** it allows you to enable the sending of the wake-up data to other devices in the same application (enabled, disabled. Default value disabled).
- **Receive backlighting wake-up on pressing other controls enabling:** it allows you to enable the receipt of the wake-up data sent by other devices in the same application (enabled, disabled. Default value disabled).
- **Icon:** it allows you to set the symbol displayed in the central LED matrix, choosing between disabled or a static image (choosing one of the symbols in the library).

Only in the case of configuration as scenario activator the following parameter is present:

Animation: it allows you to set an animation displayed in the LED matrix associated with the push button when it is pressed (disabled or animation chosen from one of the animations in the library).

Functional unit - Rocker switch

- **Rocker switch operation:** it allows you to choose the behaviour of the two push buttons.
 - Normal which sends ON when the upper push button is pressed and OFF when the lower push button is pressed regardless of the load status
 - Toggle which sends the opposite value to the load status both when the upper push button and when the lower push button are pressed; this parameter does not apply to long presses and to the roller shutter configurations (Default value "toggle").
- **Roller shutter rocker switch operation:** allows you to choose whether the stop control will be sent to the roller shutter on release of a long press (normal, or one-position stable which sends the stop on release of the rocker switch. Default value "normal").
- **Long press time:** from 0.5 ms to 30 s with default value 0.5 s.
- **Short/long press behaviour:** normal or reversed with default value "normal". This parameter is useful in the case of actuators with a timed function to invert the two ON/OFF and timer controls.
- **Send backlighting wake-up on pressing control enabling:** it allows you to enable the sending of the wake-up data to other devices in the same application (enabled, disabled. Default value disabled).
- **Receive backlighting wake-up on pressing other controls enabling:** it allows you to enable the receipt of the wake-up data sent by other devices in the same application (enabled, disabled. Default value disabled).
- **Upper icon:** it allows you to set the symbol displayed in the LED matrix associated with the upper button, choosing between disabled or a static image (choosing one of the symbols in the library).
- **Central icon:** it allows you to set what is displayed in the central LED matrix.
 - Disabled;
 - Static images (choosing one of the symbols in the library);
 - Percentage status of the controlled load (only in the case of dimmers, roller shutters and sound systems).
- **Central animation on long pressing of upper push button:** it allows you to set the animation of the central LED matrix during the control of the actuator with the upper button. It only applies in the case of dimmers/sound systems/roller shutters with a value chosen from the library of animations.
- **Central animation on long pressing of lower push button:** it allows you to set the animation of the central LED matrix during the control of the actuator with the lower button. It only applies in the case of dimmers/sound systems/roller shutters with a value chosen from the library of animations.
- **Lower icon:** it allows you to set the symbol displayed in the LED matrix associated with the lower button, choosing between disabled or a static image (choosing one of the symbols in the library).

Functional Unit - Central LED matrix

- **Receive backlighting wake-up on pressing other controls enabling:** it allows you to enable the receipt of the wake-up data sent by other devices in the same application (enabled, disabled. Default value disabled).
- **Flashing speed** (only applicable in the case of configuration with alarm): low, high. Default value "low"
- **Only in the case of "Scenario" configuration, the following parameters replace those present at device level:**
 - **Central LED matrix day standby brightness (scenario not activated):** sets the brightness value of the central matrix during the day immediately after a scenario has been called up (off, low, medium, high. Default value low).
 - **Central LED matrix day standby brightness (scenario activated - 3 s):** sets the brightness value of the central matrix during the day on standby (off, low, medium, high. Default value high).
 - **Central LED matrix night standby brightness (scenario not activated):** sets the brightness value of the central matrix during the night immediately after a scenario has been called up (off, low, medium, high. Default value low).
 - **Central LED matrix night standby brightness (scenario activated - 3 s):** sets the brightness value of the central matrix during the night on standby (off, low, medium, high. Default value high).
- **Icon:** it allows you to set the symbol displayed in the central LED matrix, choosing between disabled or a static image (choosing one of the symbols in the library).

Air quality functional unit

- **Value transmission:** Indicates the logic for sending the air quality value on the bus.
- **Transmission interval:** Indicates the difference in time between 2 values read to generate an air quality message transmission. Designed to set the period of updating the air quality value on the supervisor devices (touch screens, etc.).
- **Raw value transmission:** Indicates the logic for sending the raw (data measured internally by the sensor) air quality value on the bus.
- **Raw value transmission threshold:** Indicates the difference in time between 2 values read to generate an air quality raw data message transmission. Designed to set the period of updating the air quality value on the supervisor devices (touch screens, etc.).
- **Raw value transmission threshold:** Indicates the difference between 2 values read to generate an air quality raw data message transmission.

Air quality status functional unit

- **Trigger logic:** Indicates the logic to trigger the air quality event, with respect to the threshold value set. Not present in the scenario activation configuration.
- **Trigger threshold:** Indicates the value beyond which the air quality event occurs.

Humidity functional unit

- **Value transmission:** Indicates the logic for sending the humidity value on the bus.
- **Transmission interval:** Indicates the difference in time between 2 values read to generate a humidity message transmission. Designed to set the period of updating the humidity value on the supervisor devices (touch screens, etc.).
- **Value transmission threshold:** Indicates the difference between 2 values read to generate a humidity value message transmission.
- **Humidity calibration:** Static humidity calibration value. This is an offset to which the humidity value read by the probe must be summed.

Humidity status functional unit

- **Trigger logic:** Indicates the logic to trigger the humidity event, with respect to the setpoint and hysteresis set.
- **Setpoint:** Indicates the value beyond which the trigger logic is activated.
- **Hysteresis:** Indicates the value of the hysteresis used during the trigger logic deactivation phase.

Temperature functional unit

- **Value transmission:** Indicates the logic for sending the temperature value on the bus.
- **Transmission interval:** Indicates the difference in time between 2 values read to generate a temperature message transmission. Designed to set the period of updating the temperature value on the supervisor devices (touch screens, etc.).
- **Value transmission threshold:** Indicates the difference between 2 values read to generate a temperature value message transmission.

XT platform devices

11.9 Icons and animations

This paragraph illustrates all the icons and animations of the LED matrices (in those devices which support them) according to the configuration made.

Icons









	Meaning
None	Disabled
	Dot
	General Load/Light
	Ceiling Light
	Suspension lamp
	Floor-standing light
	Wall light
	Fan
	Roller shutter/curtain
	Right Curtain
	Left Curtain
	Bottom-hung window
	Day Scenario
	Night Scenario
	Favourite Scenario
	TV scenario
	Lunch/Dinner Scenario
	Party Scenario
	Star

	Meaning
	Generic Alarm
	ON/OFF
	Door bell
	Key
	Going Out scenario
	Entry scenario
	Paintbrush
	More
	Less
	More/Less
	Up Arrow
	Right Arrow
	Down Arrow
	Left Arrow
	Closing
	Opening
	Change Source
	Change Track

	Meaning
	Play
	Ramp
Label	-
	Slider of dots (status)
	Roller shutter/Curtain status (in other words the number of rows increases or decreases depending on the real status of the roller shutter/curtain)
	Right Curtain status (in other words the number of rows increases or decreases depending on the real status of the curtain)
	Left Curtain status (in other words the number of rows increases or decreases depending on the real status of the curtain)
	Up Arrow (small)
	Right Arrow (small)
	Down Arrow (small)
	Left Arrow (small)
	More (small)
	Less (small)
	Up/Down Arrow
	Right scale
	Left scale

XT platform devices

Animations

	Meaning
None	Disabled
	Slider of dots upwards
	Slider of dots downwards
	Roller shutter opening
	Roller shutter closing
	Curtain drawing from left to right
	Curtain drawing from right to left
	Going Out scenario
	Entry scenario

APPENDIX: Summary table of By-me device absorption rates
I. SUMMARY TABLE OF By-me DEVICE ABSORPTION RATES

Type	Description	Absorption
01417	Home autom. actuator+RGBW 4OUT dimmer	10 mA
01418	Home autom.dimmer 2OUT200W LED120-240V	15 mA
22481.x	Vintage 1Lever Home Aut.Control	3 mA
22482.x	Vintage 2Lever Home Aut.Control	7.5 mA
30480 01480	Home automation system control with 4 push buttons	7.5 mA
30481 01481	Home automation system control with 4 push buttons + relay actuator	7.5 mA
30482 01482	Home automation system control with 4 push buttons + roller shutter/slat actuator	25 mA
30485 01485	Home automation system control with 6 buttons	7.5 mA
30486 01486	Home automation system control with 6 push buttons + relay actuator	7.5 mA
30487 01487	Home automation system control with 6 push buttons + roller shutter/slat actuator	25 mA
30488 01488	Home automation system control with 4 push buttons + LED 240V dimmer	15 mA
30489 01489	Home automation system control with 4 push buttons + 0/1-10V dimmer	25 mA
01418	Home automation system dimmer with 2 outputs 200W, LED 120-240V	15 mA
01470.1	Home automation system multifunction module with 9 inputs and 8 preprogrammed outputs	10 mA
01471	Multifunction home automation system actuator with 4 relay outputs	20 mA
01475	Home automation system module with 3 digital inputs, 3 outputs for LED control	15 mA
01476	Home automation system module with 2 digital inputs 1 roller shutter output and 2 outputs for LED control	20 mA
01477	Home automation system module with 2 digital inputs, 1 relay output and 2 outputs for LED control	15 mA
20582 19582 14582	Audio input with 2 RCA connectors	35 mA
01900	FM radio tuner with RDS	35 mA
30495 20589 19589 14589	Bluetooth interface for home automation system	35 mA
20586 19586 14586	Call microphone	35 mA
01483	Home automation system control with 4 push buttons and 1 LINE output	35 mA
30484 01484	Home automation system control with 4 push buttons and 1+1 W stereo amplifier	150 mA if powered via Bus 10 mA if powered via 32 V power supply unit
01901	Stereo amplifier with 2 outputs for 8 ohm 10+10 W speakers	250 mA a 230 V~, cos ϕ 0.5 390 mA a 120 V~, cos ϕ 0.6
20590 19590 14590	4+4 W stereo amplifier with Bluetooth receiver	5 mA in OFF 60 mA in Standby (audio output OFF) 950 mArms in IDLE (audio output ON)
20584.1 19584.1 14584.1	Interface for transmission of By-me controls to IR receiver	20 mA

APPENDIX: Summary table of By-me device absorption rates

Type	Description	Absorption
01450	Energy meter with 3 inputs for toroidal sensor	5 mA
01451	Energy meter with current sensor	5 mA
01452	Pulse counter interface	10 mA
01455	Load control module with 3 inputs for toroidal current sensor	5 mA
01456	Actuator with relay output 16A with current sensor	5 mA
30474 20537 19537 14537	Actuator with relay output 16A with current sensor	5 mA
01465	HVAC controller for heating systems	5 mA
01466.1	Home automation system actuator with 4 proportional analogue outputs	5 mA
01467	Home automation system interface with 3 analogue inputs	20 mA
02951	Home automation system touch thermostat	5 mA
30471 02971	Wheel-Thermostat Home Automation	17.5 mA
30478 20538 19538 14538	Home automation system temperature probe	5 mA
20508 19508 14508	EnOcean BUS interface	20 mA
20535 19535 14535	Actuator with 1 relay output	10 mA
30472 20518 19518 14518	Interface for 2 conventional controls	15 mA
21514.F	Home-Thermostat FAN	50 mA
21514.H	Home-Thermostat HOTEL	50 mA
21514.S	Home-Thermostat STAR	50 mA
21520.1	Eikon Tactil home automation system control with 4 push buttons	14 mA with LEDS off 27 mA with LEDS on or low brightness
21540.1	Eikon Tactil home automation system control with 6 push buttons	14 mA with LEDS off 27 mA with LEDS on or low brightness
32002	By-me XT 2 relay actuator	10 mA
32021	By-me XT Control	7.5 mA
32023	By-me advanced XT Control	12.5 mA
32024	By-me advanced XT Double control	12.5 mA
32031	By-me XT Control	7.5 mA
32033	By-me advanced XT Control	12.5 mA
32034	By-me advanced XT Double control	12.5 mA
32041	By-me XT Thermostat	15 mA
32042	XT Multisensor	15 mA
32044	XT climate control	12.5 mA

II. OPERATION OF ACTUATORS FOR ART. 01470.1, 01471, 01476 AND 01477

This section graphically illustrates the operation of roller shutter and relay actuators depending on the settings made in the configuration phase and on their parameters.

RELAY ACTUATORS

- One-position stable with ON delay

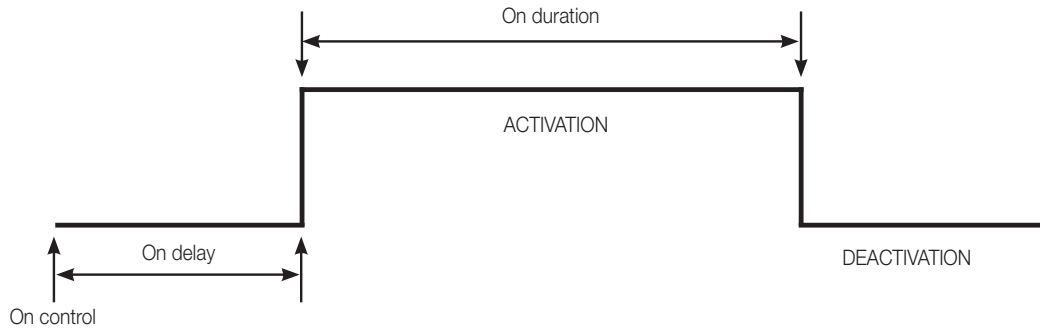

- One-position stable with ON and OFF delay

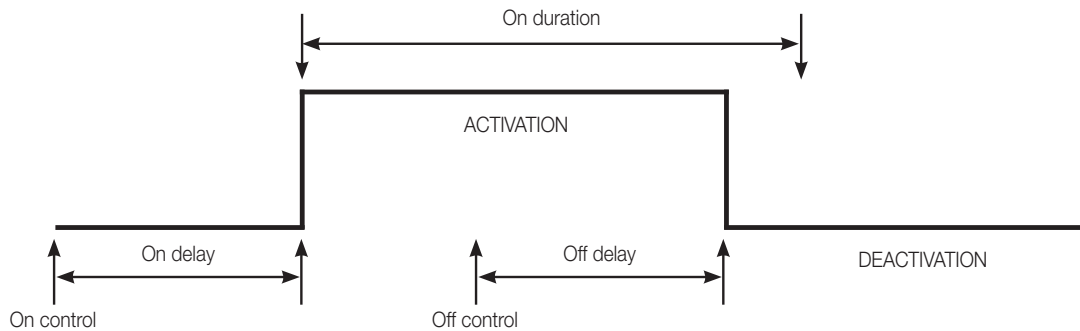

- Two-position stable with ON and OFF delay

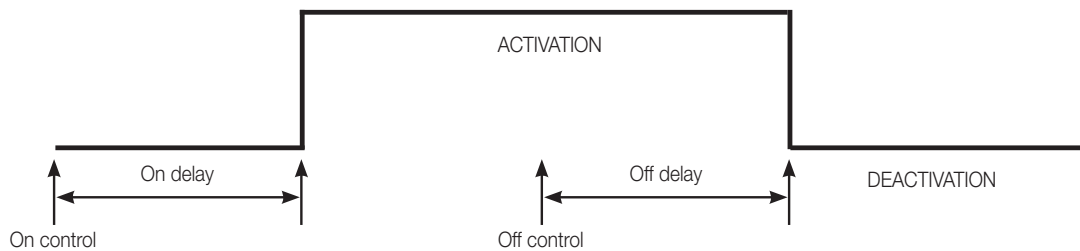

- Behaviour of one-position stable actuator for POWER DOWN/UP

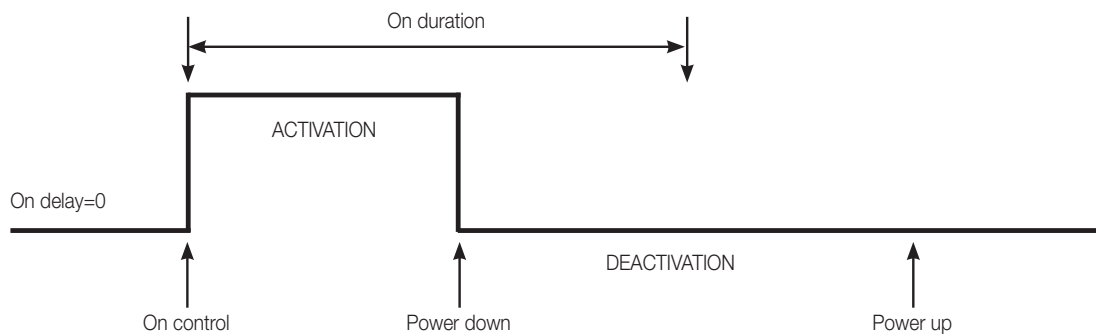

APPENDIX: Operation of actuators for art. 01470.1, 01471, 01476 and 01477

- Behaviour of two-position stable actuator for POWER DOWN/UP

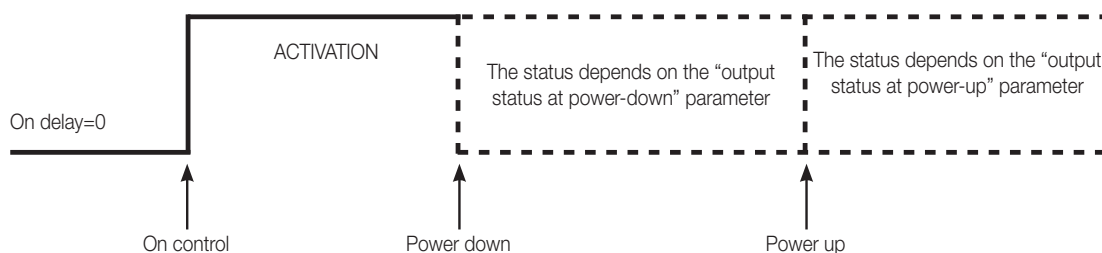

ROLLER SHUTTER ACTUATOR

- Request to raise the roller shutter and later on a request to lower it.

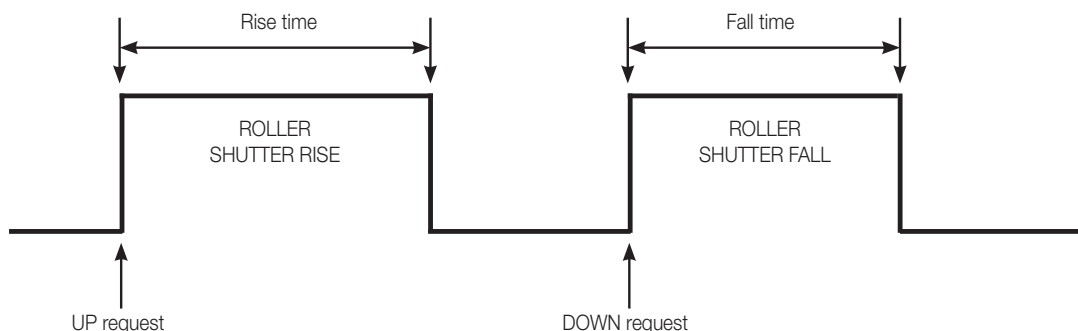

- Request to raise the roller shutter and later on a request to lower it while it is raising. The "controls execution delay" parameter is set to a value other than 0.

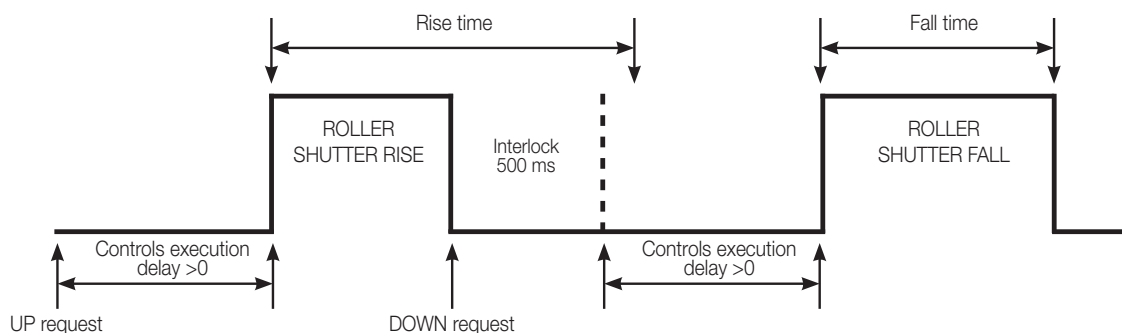

- Request for positioning the roller shutter at a certain value (this case is similar also in the case of calling up a scene).

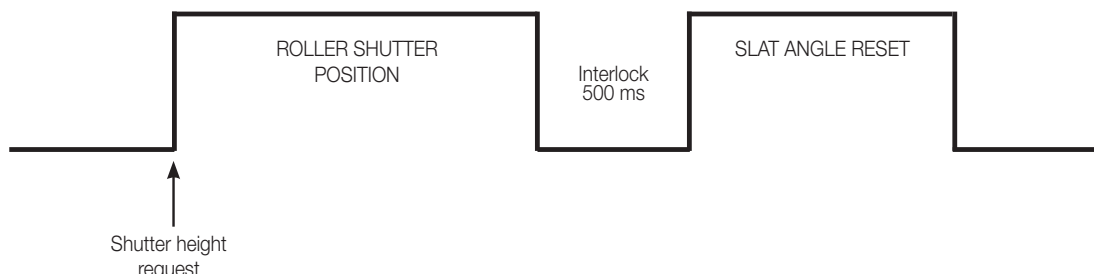

APPENDIX: Operation of actuators for art. 01470.1, 01471, 01476 and 01477

- Behaviour of the actuator in the event of close slat rotation requests (the "controls execution delay" parameter is always null for the slats).

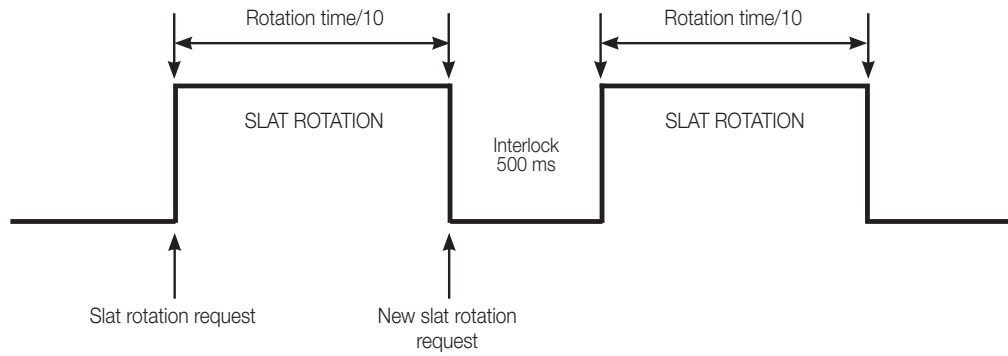

- Request for forcing during the movement of the roller shutter

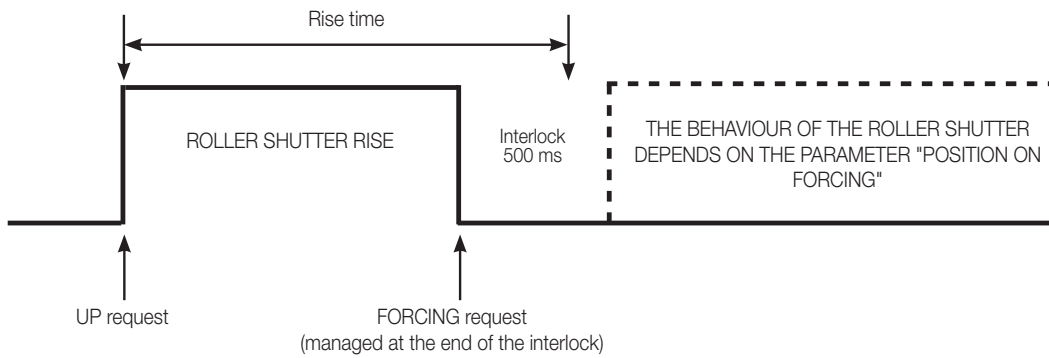

- Request for scene saving during the movement of the roller shutter

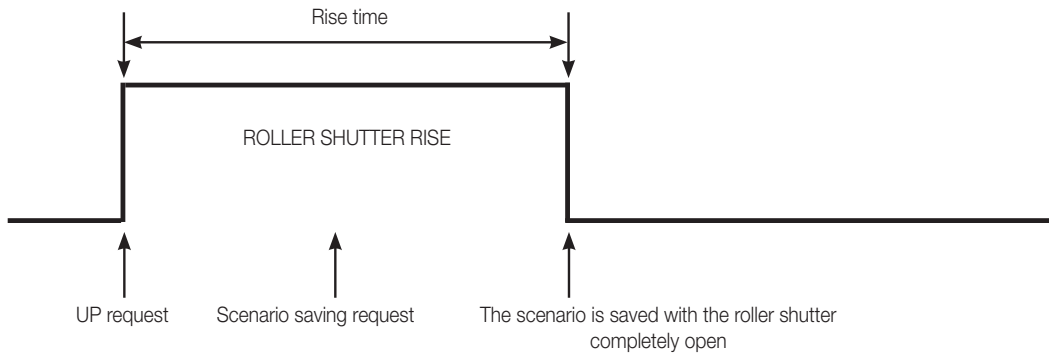

- Request for forcing during the interlock period

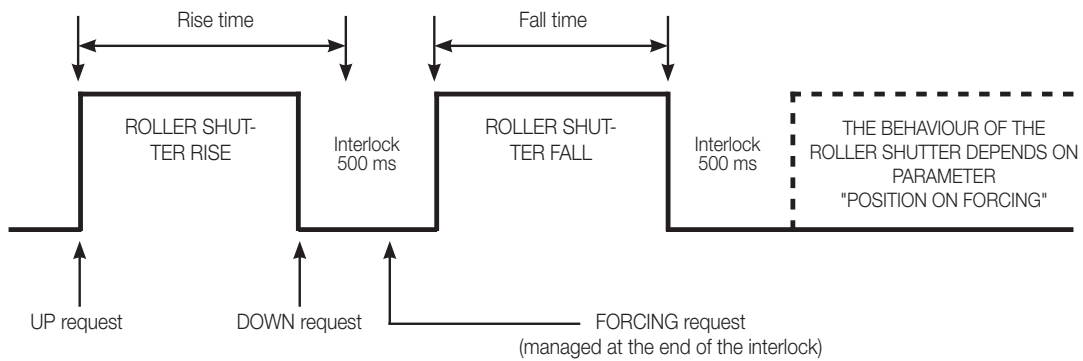

APPENDIX: Operation of actuators for art. 01470.1, 01471, 01476 and 01477

- Setting an absolute value for slat rotation during the movement of the roller shutters

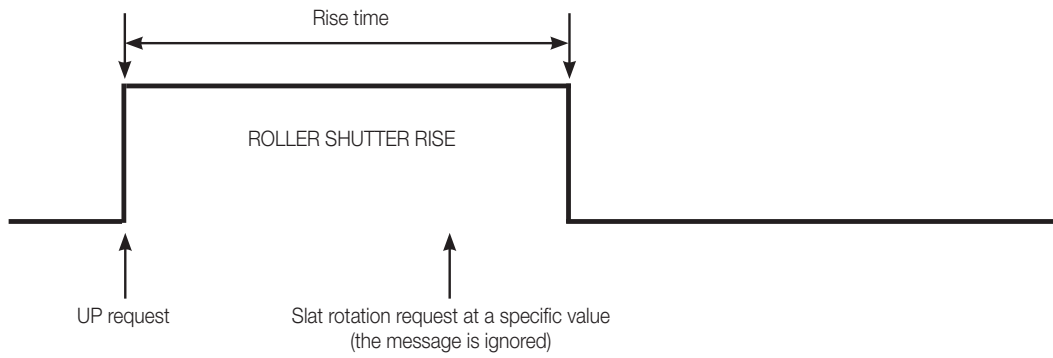

APPENDIX: Examples of using the functional units of thermostats

III. EXAMPLES OF USING THE FUNCTIONAL UNITS OF THERMOSTATS.

This chapter graphically illustrates how to associate the functional units of By-me and Eikon Tactil thermostats in applications to implement some of the most commonly used functions.

CONFIGURING THE HUMIDITY FUNCTIONAL UNIT

This shows the humidity on the thermostat display (do not configure the functional unit if this is not required). This feature can be implemented on thermostats art. 02951, 21514.F and 21514.S by creating a dedicated Sensors application.

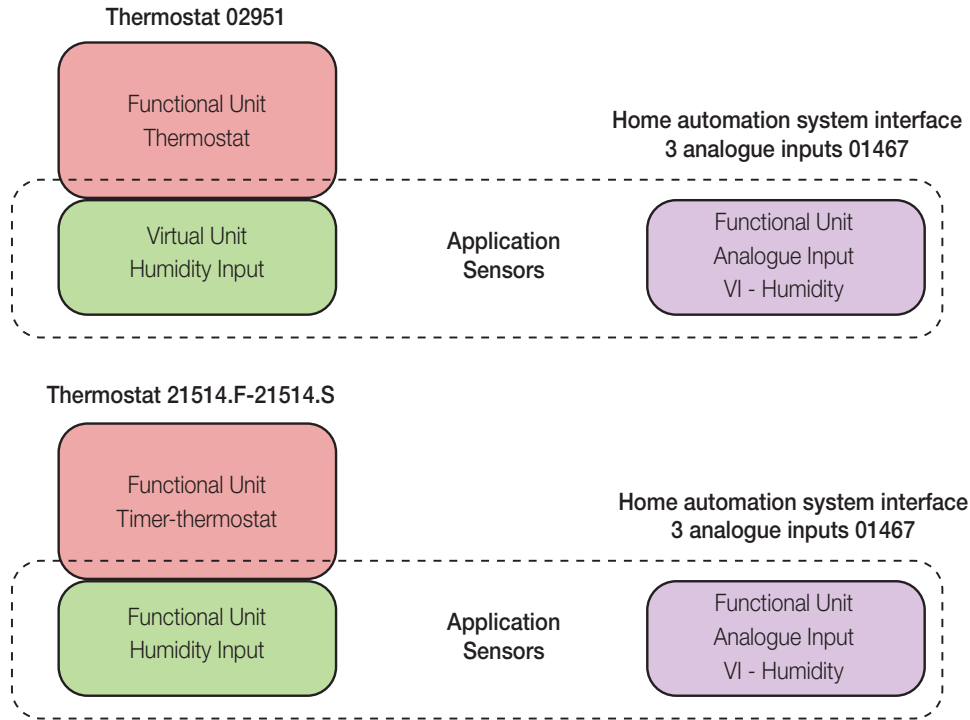

NOTE: Multiple Humidity Input units of various thermostats/HVAC controllers can be added to the same Sensors application.

CONFIGURING THE PROBE 2 FUNCTIONAL UNIT

This shows the temperature of probe 2 on the thermostat display and touch screens (via a dedicated Sensors application). This feature can be implemented on thermostats art. 32041, 02951, 30471-02971, 21514.F, 21514.H and 21514.S and multisensor art. 32042 by creating a dedicated sensors application.

N.B. In the 21514.H thermostat, the temperature measured by probe 2 can be displayed on the View app, but not on the device display.

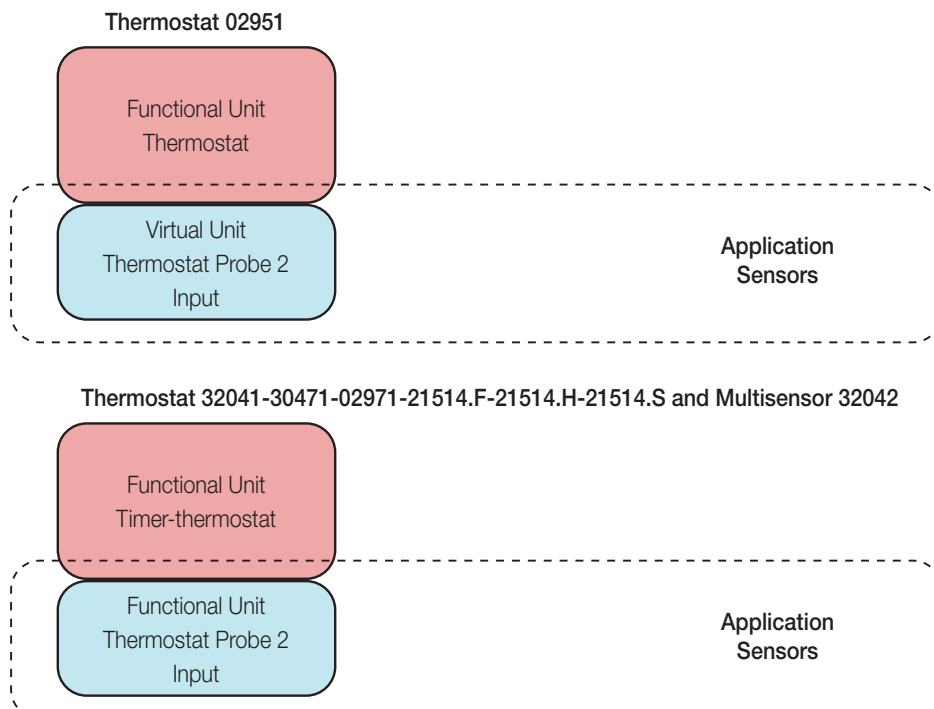

APPENDIX: Examples of using the functional units of thermostats

XT THERMOSTAT 32041 AND XT MULTISENSOR 32402

It allows you to view the temperature value sent to the bus by another thermostat or temperature sensor on the display of XT thermostat 32041 and of XT multisensor 32042 or to use it for the temperature control logics.

This function can be performed with XT thermostat art. 32041 or with XT multisensor art. 32042 by inserting the functional unit "Probe 2 Thermostat from bus Input" functional unit in a Sensors application that includes the functional unit of a home automation system interface or of an HVAC controller or another thermostat.

Thermostat 32041 and Multisensor 32042

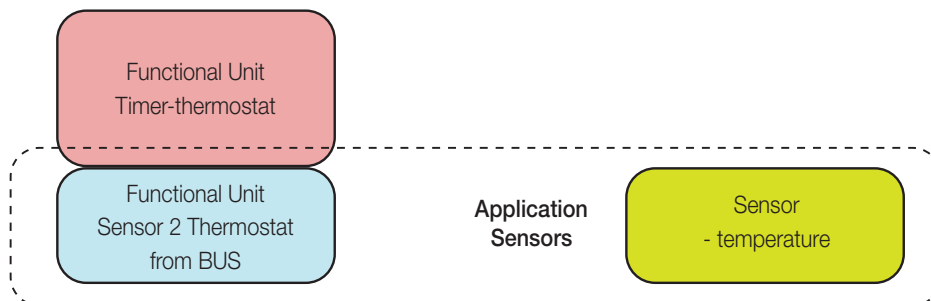

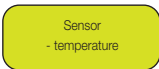
N.B.  = "Probe 2 Thermostat Input" functional unit of all thermostats except for XT art. 32041 and multisensor art. 32042.
 Home automation system interface with 3 analogue inputs art. 01467
 HVAC controller for heating systems art. 01465 (external/auxiliary probes)

N.B.: Multiple Probe 2 Temperature units of various XT thermostats art. 32041 and XT multisensor art. 32042 can be added to the same Sensors application.

CONFIGURING THE WINDOW FUNCTIONAL UNIT

Below are three use cases with the devices listed in the table:

CASE	ARTICLE
1	02951
2	30471-02971, 21514.F, 21514.H and 21514.S
3	32041, 30471-02971, 21514.F, 21514.H, 21514.S and 32042

CASE 1 - CONFIGURING THE WINDOW FUNCTIONAL UNIT

This can be used to switch off the thermostat if a window is open and give an indication on the display.

This feature can be implemented with thermostat art. 02951 by creating a dedicated Climate Control application that includes the functional unit of a contact interface or home automation system module.

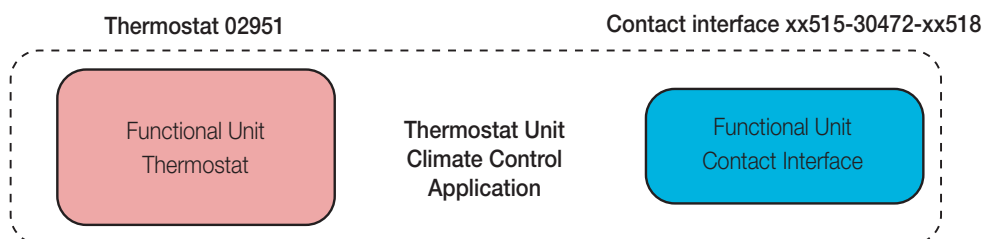

NOTE  = Contact interface art. 20515-19515-141515 and 30472-20518-19518-14518
 9in/8out home automation system module art. 01470.1 (ver. 3.0 and later)
 3in/3out home automation system module art. 01475 (ver. 2.0 and later)
 2in/3out (1 roller shutter) home automation system module art. 01476 (ver. 2.0 and later)
 2in/3out (1 relay) home automation system module art. 01477 (ver. 2.0 and later)

APPENDIX: Examples of using the functional units of thermostats

CASE 2 - CONFIGURING THE WINDOW FUNCTIONAL UNIT

This can be used to switch off the thermostat if a window is open and give an indication on the display and touch screen (on the Accesses application); the contact wired physically on the thermostat is used in this case.

This feature can be implemented on thermostats art. 02951, 30471-02971, 21514.F, 21514.H and 21514.S by creating a dedicated Accesses application and selecting the Thermostat Contact Input functional unit while creating it.

Thermostat 30471-02971-21514.F-21514.H-21514.S

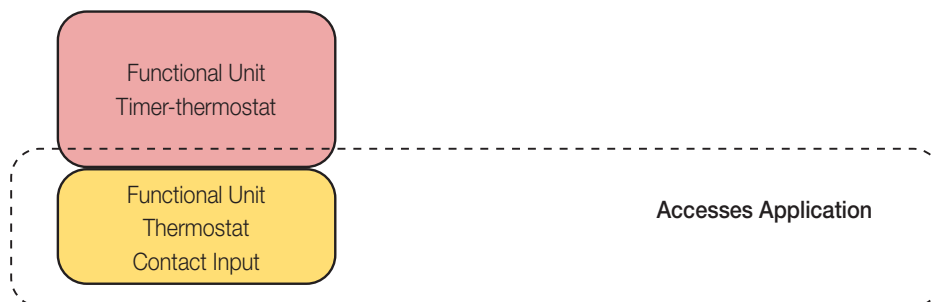

NOTE: The Accesses application can then be used to configure the WINDOW CONTACT INPUT FROM BUS functional units of other thermostats in order to switch them off from a single Window contact.

CASE 3 - CONFIGURING THE WINDOW FUNCTIONAL UNIT

This can be used to switch off the thermostat if a window is open and give an indication on the display and touch screen (on the Accesses application).

This feature can be implemented with thermostats art. 30471-02971, 21514.F, 21514.H, 21514.S and multisensor art. 32042 by creating a dedicated Accesses application that includes the functional unit of a contact interface or home automation system module. The Contact Interface functional unit must be selected while creating the application.

Thermostat 32041-30471-02971-21514.F-21514.H-21514.S and Multisensor 32042

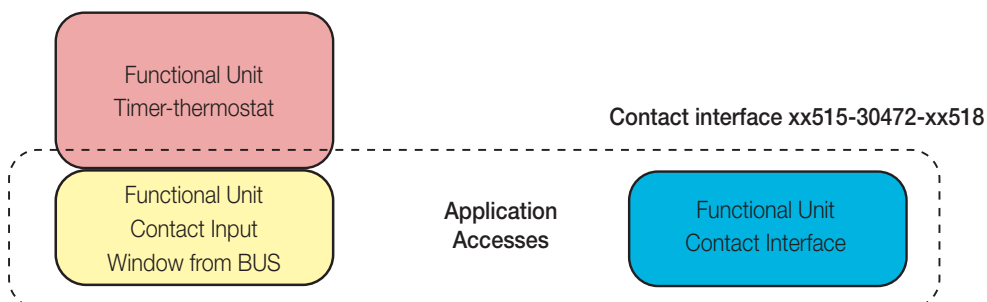

NOTE  = Contact interface art. 20515-19515-141515 and 30472-20518-19518-14518
 9in/8out home automation system module art. 01470.1 (ver. 3.0 and later)
 3in/3out home automation system module art. 01475 (ver. 2.0 and later)
 2in/3out (1 roller shutter) home automation system module art. 01476 (ver. 2.0 and later)
 2in/3out (1 relay) home automation system module art. 01477 (ver. 2.0 and later)

NOTE: The Accesses application can then be used to configure the WINDOW CONTACT INPUT FROM BUS functional units of other thermostats in order to switch them off from a single Window contact.

APPENDIX: Examples of using the functional units of thermostats

CASE 1 - CONFIGURING THE THERMOSTAT SHUT-DOWN CONTACT FUNCTIONAL UNIT

This can be used to switch off the thermostat if the boiler shuts down and give an indication on the display and touch screen (on the Sensors application); the contact wired physically on the thermostat is used in this case.

This feature can be implemented on thermostats art. 30471-02971, 21514.F, 21514.H and 21514.S by creating a dedicated Sensors application and selecting the Thermostat Input Contact functional unit while creating it.

Thermostat 30471-02971-21514.F-21514.H-21514.S

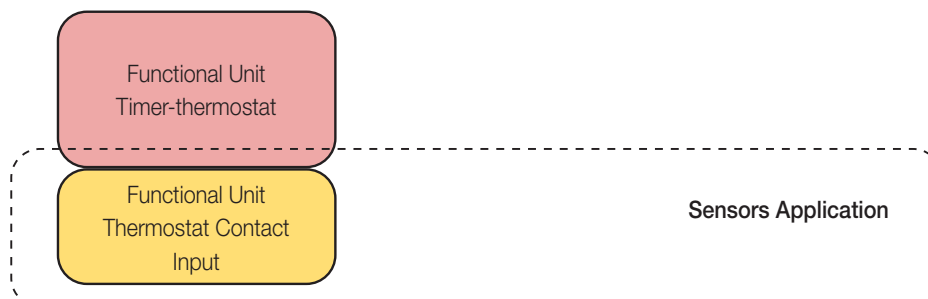

NOTE: The Sensors application can then be used to configure the SHUT-OFF CONTACT INPUT FROM BUS functional units of other thermostats in order to switch them off from a single contact.

CASE 2 - CONFIGURING THE THERMOSTAT SHUT-DOWN CONTACT

This can be used to switch off the thermostat if the boiler shuts down and give an indication on the display and touch screen (on the Sensors application).

This feature can be implemented with thermostats art. 30471-02971, 21514.F, 21514.H and 21514.S and multisensor art. 32042 by creating a dedicated Sensors application that includes the functional unit of a contact interface or home automation system module. The Contact Interface functional unit must be selected while creating the application.

Thermostat 32041-30471-02971-21514.F-21514.H-21514.S and Multisensor 32042

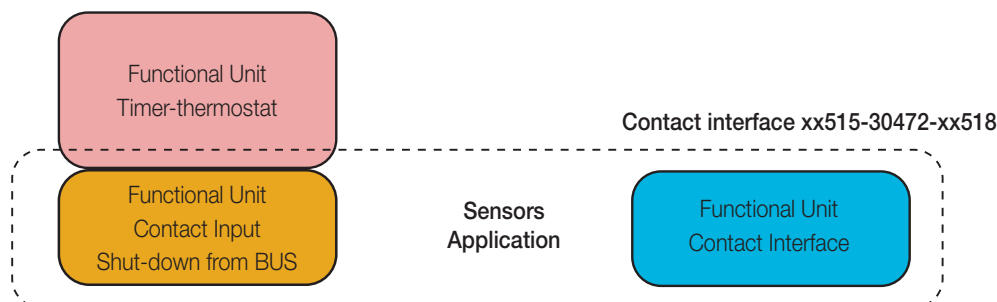

NOTE  = Contact interface art. 20515-19515-141515 and 30472-20518-19518-14518
 9in/8out home automation system module art. 01470.1 (ver. 3.0 and later)
 3in/3out home automation system module art. 01475 (ver. 2.0 and later)
 2in/3out (1 roller shutter) home automation system module art. 01476 (ver. 2.0 and later)
 2in/3out (1 relay) home automation system module art. 01477 (ver. 2.0 and later)

NOTE: The Sensors application can then be used to configure the SHUT-OFF CONTACT INPUT FROM BUS functional units of other thermostats in order to switch them off from a single contact.

APPENDIX: Examples of using the functional units of thermostats

CONFIGURATION OF THE DELIVERY TEMPERATURE FUNCTIONAL UNIT

Designed to provide the thermostat with delivery temperature value and view it on touch screens (via a dedicated sensors application), used by the device to calculate the dewpoint.

This function can be achieved with multisensor art. 32042, by creating a dedicated sensors application (the multisensor does not adjust the delivery temperature but it closes the valve for safety to prevent condensation).

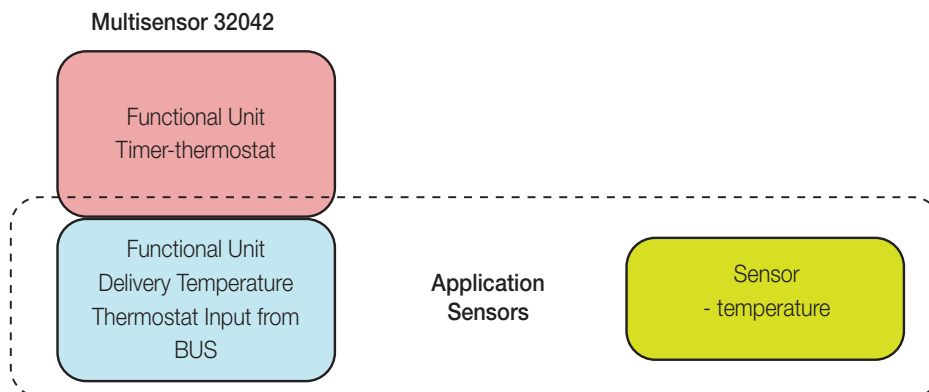

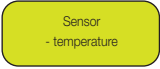
N.B.  = "Delivery temperature thermostat input from BUS" functional unit of all thermostats except for XT art. 32041 and multisensor art. 32042.
 Home automation system interface with 3 analogue inputs art. 01467
 HVAC controller for heating systems art. 01465 (external/auxiliary probes)

N.B.: Multiple Delivery temperature thermostat input from BUS functional units of various XT Multisensors art. 32042 can be added to the same Sensors application.

CONFIGURATION OF THE CONTROL FUNCTION UPON HUMIDITY EVENTS

Designed to control a load/actuator upon exceeding the humidity threshold configured using the dedicated parameter.

This function can be achieved with XT multisensor art. 32042, by creating:

- a sensors application to view the humidity value;
- a load/actuator control application (for instance lights/access/miscellaneous of the on-off type).

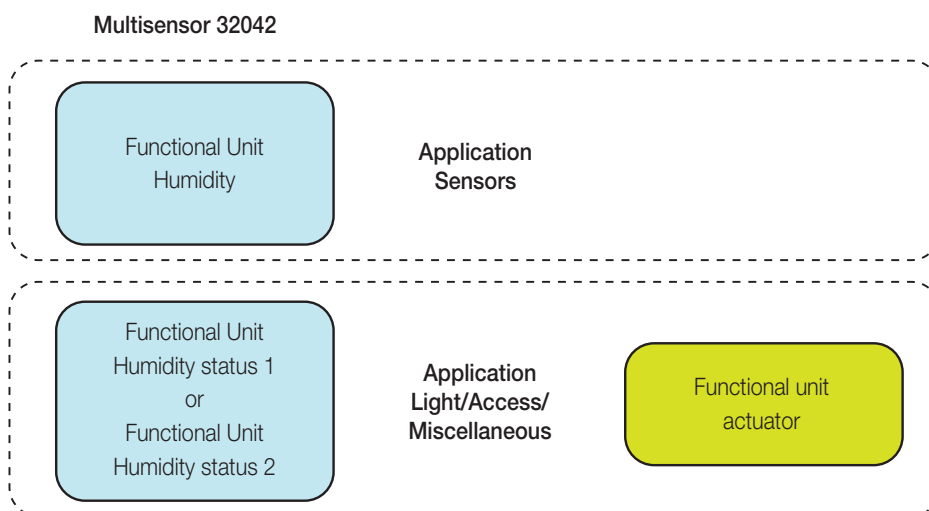

Every humidity value sent via bus by the "Humidity Functional Unit" is read by the "Humidity Status 1 Functional Unit" and/or "Humidity Status 2 Functional Unit" and processed to operate the "Actuator functional unit" in the same application.

The control logic of the "Actuator functional unit" is defined using the "Trigger logic, Setpoint, Hysteresis" parameters set in the "Humidity Status 1 Functional Unit" or "Humidity Status 2 Functional Unit". In addition, the control logic can be linked to the operating mode of the "Thermostat functional unit" using the "device" parameter **Thermostat connection with humidity status**:

- If **Thermostat connection with humidity status** = Enabled, the control logic of the "Actuator functional unit" is active when the thermostat is ON (Auto, Manual, Timed manual and Reduction mode). When the thermostat is OFF (Off, Absence and Protection), the logic is not active and the "Humidity Status 1 Functional Unit" or "Humidity Status 2 Functional Unit" does not send controls to the actuator.
- If **Thermostat connection with humidity status** = Disabled, the control logic of the "Actuator functional unit" is always active regardless of whether the thermostat is ON or OFF.

APPENDIX: Examples of using the functional units of thermostats

CONFIGURATION OF THE CONTROL FUNCTION UPON AIR QUALITY EVENTS

Designed to control a load/actuator upon exceeding the air quality threshold configured using the dedicated parameter.

This function can be achieved with XT multisensor art. 32042, by creating:

- a sensors application to view the air quality level value;
- a load/actuator control application (for instance lights/access/miscellaneous of the on-off type).

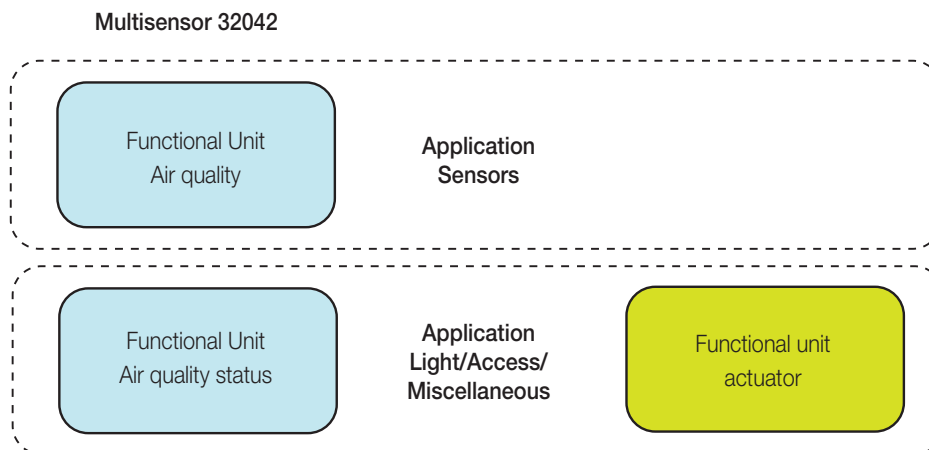

Every air quality value sent via bus by the "Air Quality Functional Unit" is read by the "Air Quality Status Functional Unit" and processed to operate the "Actuator functional unit" in the same application.

The control logic of the "Actuator functional unit" is defined using the "Trigger logic, Setpoint, Hysteresis" parameters set in the "Air Quality Status Functional Unit". In addition, the control logic can be linked to the operating mode of the "Thermostat functional unit" using the "device" parameter **Thermostat connection with air quality status**:

- If **Thermostat connection with air quality status** = Enabled, the control logic of the "Actuator functional unit" is active when the thermostat is ON (Auto, Manual, Timed manual and Reduction mode). When the thermostat is OFF (Off, Absence and Protection), the logic is not active and the "Air Quality Status Functional Unit" does not send controls to the actuator.
- If **Thermostat connection with air quality status** = Disabled, the control logic of the "Actuator functional unit" is always active regardless of whether the thermostat is ON or OFF.

N.B.: Alternatively to this function, the Air Quality status functional unit can be used to create a scenario activator for the same event (see paragraph 4.3.9 SCENARIOS application in this manual).



By-me Plus 25 2604