

32002

XT electronic control device for By-me home automation system with 100-240 V 50/60 Hz relay output for 500 W incandescent lamps, 100 W LED lamps, 250 VA electronic transformers, 120 W fluorescent lamps, 1 roller shutter operated by 2 A cosØ 0.6 motor, to be installed on XT mounting frames, to be completed with By-me XT front modules.

CHARACTERISTICS.

- Rated supply voltage: BUS 29 V derived from the electrified XT mounting frame through spring contacts.
- Maximum absorption from the BUS: 10 mA (the device does not absorb current from the power supply node 32001).
- Terminals:
 - 2 for L and N (voltage 100-240 V~ 50/60 Hz);
 - 2 for the OUT 1 and OUT 2 voltage outputs that control 2 lights or a roller shutter.
- Buttons 1 and 2 for manual relay control.
- LED and OFF push button for configuration/reset.
- Switching on zero crossing.
- Protection degree: IP20.
- Operating temperature: -5 °C ÷ +45°C (indoor use).
- Overall dimensions: 1 module measuring 22.5 mm.

CONTROLLABLE LOADS (20.000 Cycles).

- With the outputs used to control 2 lights:

Max loads for each output				
100 V~	250 W	50 W	60 W	125 VA
240 V~	500 W	100 W	120 W	250 VA

- With the outputs used as a single roller shutter output:

Maximum loads	Roller shutter motor
100 V~	2 A cos ø 0.6
240 V~	2 A cos ø 0.6

N.B. The device is not suitable for controlling relays configured in climate control applications.

MANUAL MANAGEMENT.

CAUTION: In order to function, the actuator must be installed in the electrified XT mounting frame together with the related power supply node. The buttons should be pressed once the device is installed.

The 2 front buttons can always be used for the manual control of the 2 outputs

- If the device has not been configured (in other words the factory values are set) the relays are controlled by buttons 1 and 2 for the UP (▲) and DOWN (▼) functions respectively; there is a reversal time in the passage from UP (▲) to DOWN (▼) to protect any motor connected to the outputs.
- If the device has been configured:
 - with the relays configured individually, relay 1 is controlled in toggle mode by button 1 while relay 2 is controlled by button 2;
 - with the relays configured to control the roller shutter, they are controlled by buttons 1 and 2 for the UP (▲) and DOWN (▼) functions with a reversal time in the passage from UP (▲) to DOWN (▼).

CONFIGURATION with View Pro App.

For full details, see the manuals, which can be downloaded from the website www.vimar.com.

INSTALLATION RULES.

- Installation and configuration must be carried out by qualified persons in compliance with the current regulations regarding the installation of electrical equipment in the country where the products are installed.
- The device should be installed on electrified XT mounting frames with:
 - 2 modules art. 32602.x (for 2-module mounting box)
 - 3 modules art. 32603.x (for 3-module rectangular mounting box)
 - 4 modules art. 32604.x and 32614.x (for 4-module rectangular mounting box)
- To install the actuator, slide up the protection flap on the back of the mounting frames.
- The relay output power supply circuit must be protected against overloads by installing a fuse device with a nominal breaking capacity of 1500 A or automatic 1-way switch type C, with a rated current not exceeding 10 A.

FRONT AND REAR VIEW

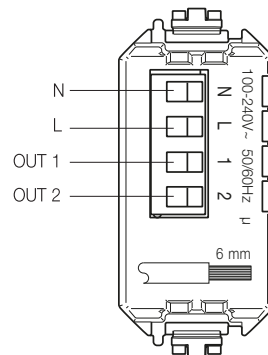
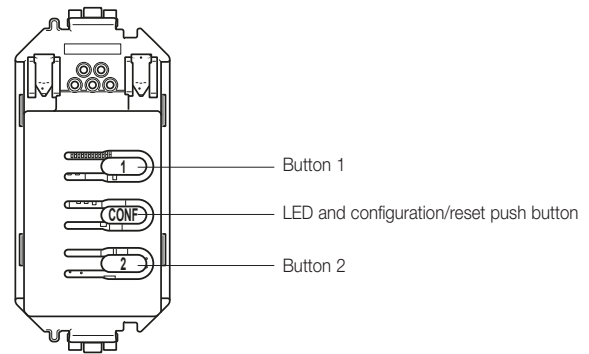

REGULATORY COMPLIANCE.

LV Directive. EMC directive. RoHS directive.
 IEC 60669-2-1, EN 50491-2, EN IEC 63044, EN IEC 63000 standards.
 REACH (EU) Regulation no. 1907/2006 – Art.33. The product may contain traces of lead.



WEEE - User information

The crossed bin symbol on the appliance or on its packaging indicates that the product at the end of its life must be collected separately from other waste. The user must therefore hand the equipment at the end of its life cycle over to the appropriate municipal centres for the differentiated collection of electrical and electronic waste. As an alternative to independent management, you can deliver the equipment you want to dispose of free of charge to the distributor when purchasing a new appliance of an equivalent type. You can also deliver electronic products to be disposed of that are smaller than 25 cm for free, with no obligation to purchase, to electronics distributors with a sales area of at least 400 m². Proper sorted waste collection for subsequent recycling, processing and environmentally conscious disposal of the old equipment helps to prevent any possible negative impact on the environment and human health while promoting the practice of reusing and/or recycling materials used in manufacture.

CONNECTION TO CONTROL TWO LIGHTS

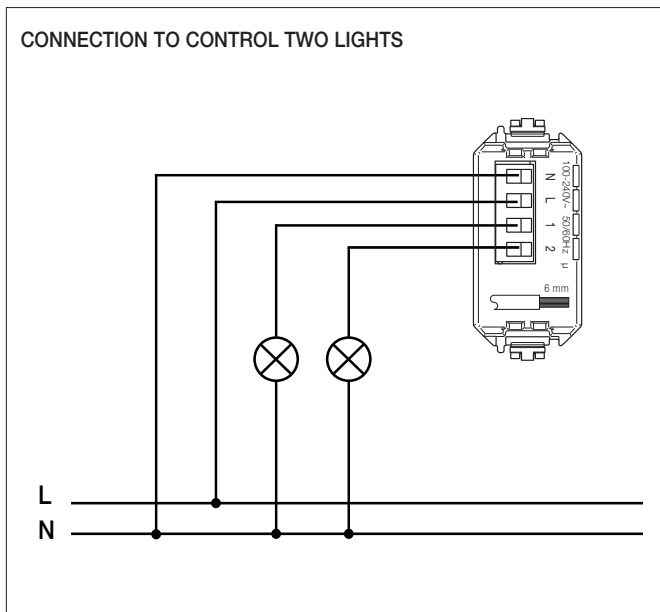

CONNECTION TO CONTROL ONE ROLLER SHUTTER

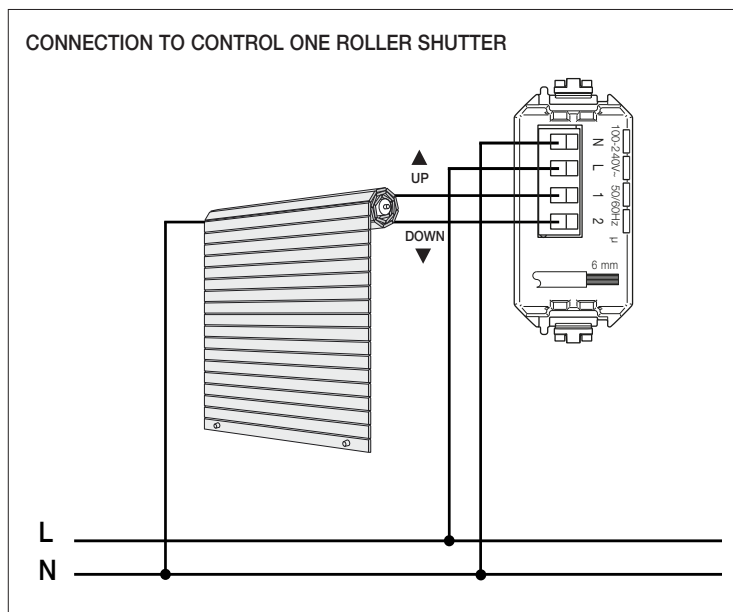

INSTALLATION EXAMPLE

Observe the direction of installation specified as UP. The hooking and unhooking of the device takes place on the back of the mounting frame regardless of the adjacent connector blocks and in any position.

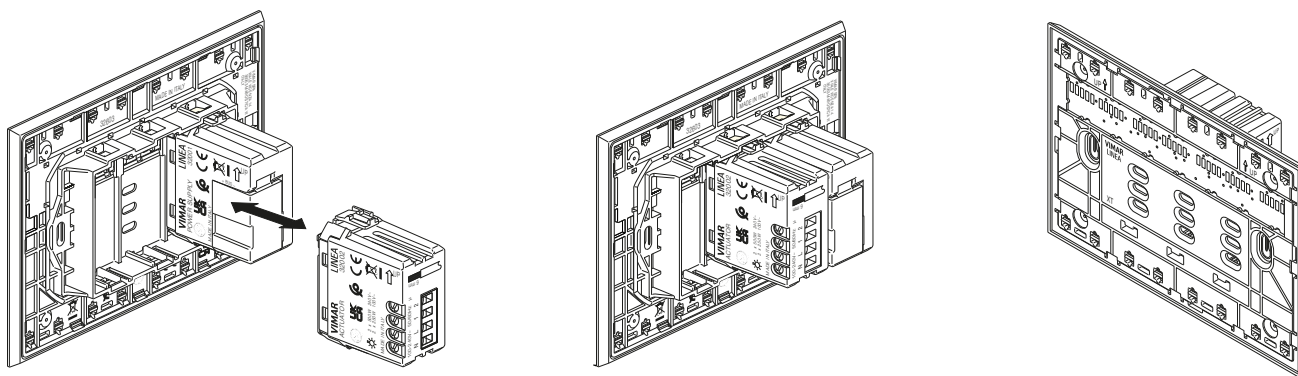

HOOKING THE DEVICE

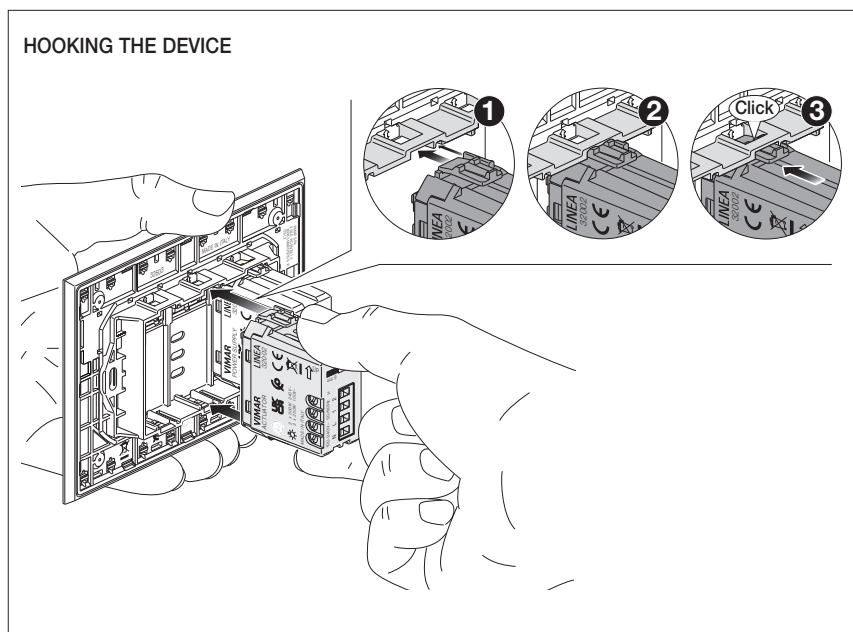

REMOVING THE DEVICE

